

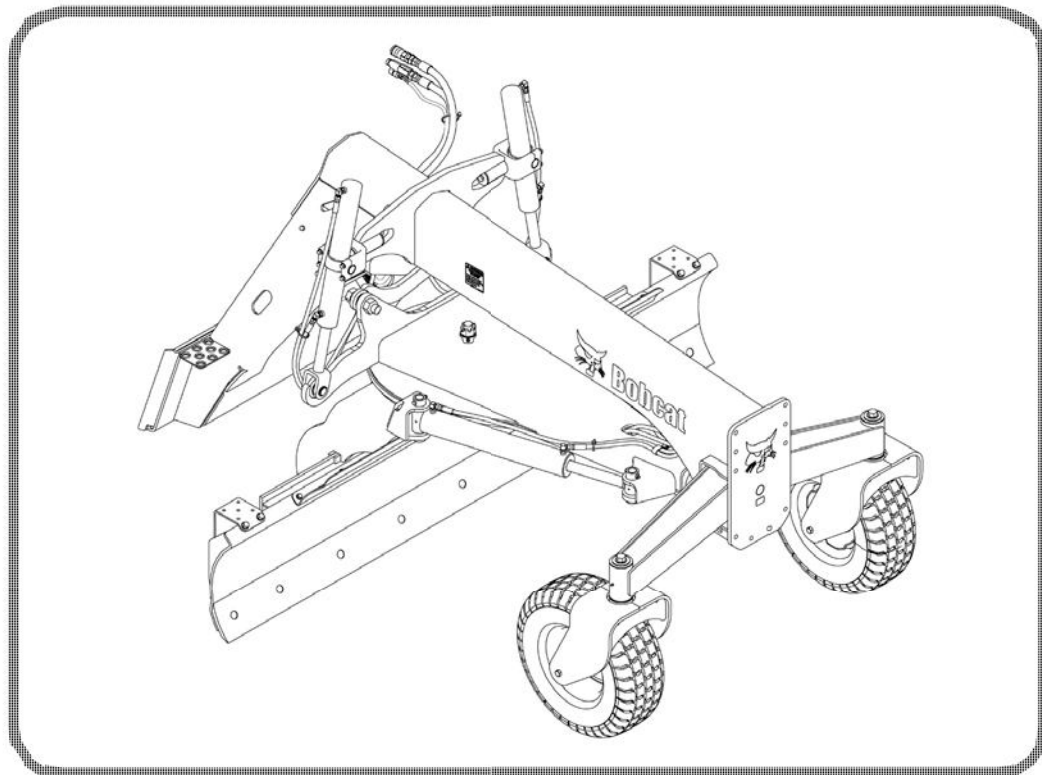

Bobcat®

Service Manual Grader

(Grader 96) S/N ACW900101 & Above
(Grader 108) S/N AJ2E00101 & Above



Dealer Copy -- Not for Resale



MAINTENANCE SAFETY



WARNING







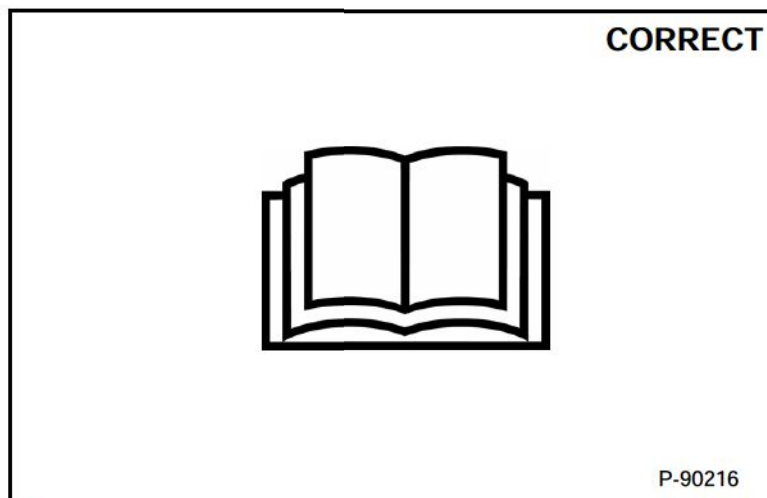

Instructions are necessary before operating or servicing machine. Read and understand the Operation & Maintenance Manual, Operator's Handbook and signs (decals) on machine. Follow warnings and instructions in the manuals when making repairs, adjustments or servicing. Check for correct function after adjustments, repairs or service. Untrained operators and failure to follow instructions can cause injury or death.

W-2003-0807



Safety Alert Symbol: This symbol with a warning statement, means: "Warning, be alert! Your safety is involved!" Carefully read the message that follows.



-  Never service attachments / implements without instructions. See Operation & Maintenance Manual and Attachment / Implement Service Manual.
-  Cleaning and maintenance are required daily.
-  Never service or adjust attachment / implement with the engine running unless instructed to do so in manual.
-  Always lower the attachment / implement to the ground before lubricating or servicing.
-  Avoid contact with leaking hydraulic fluid or diesel fuel under pressure. It can penetrate skin or eyes.
-  Stop, cool and clean engine of flammable materials before checking fluids.
-  Keep body, loose objects and clothing away from moving parts, electrical contacts, hot parts and exhaust.
-  Safety glasses are needed for eye protection from electrical arcs, battery acid, compressed springs, fluids under pressure and flying debris or when tools are used. Use eye protection approved for type of welding.

Dealer Copy -- Not for Resale

MSW30-0409

CONTENTS

SAFETY AND MAINTENANCE	10-01
HYDRAULIC SYSTEM	20-01
MAINFRAME	30-01
SPECIFICATIONS	SPEC-01
ALPHABETICAL INDEX	INDEX-01

FOREWORD

SERIAL NUMBER LOCATION	1-7
Attachment Serial Number	1-7
DELIVERY REPORT	1-7
ATTACHMENT IDENTIFICATION	1-8

<https://www.ebooklibonline.com>

Hello dear friend!

Thank you very much for reading.

Enter the link into your browser.

The full manual is available for immediate download.

<https://www.ebooklibonline.com>

SERIAL NUMBER LOCATION

Attachment Serial Number

Figure 1

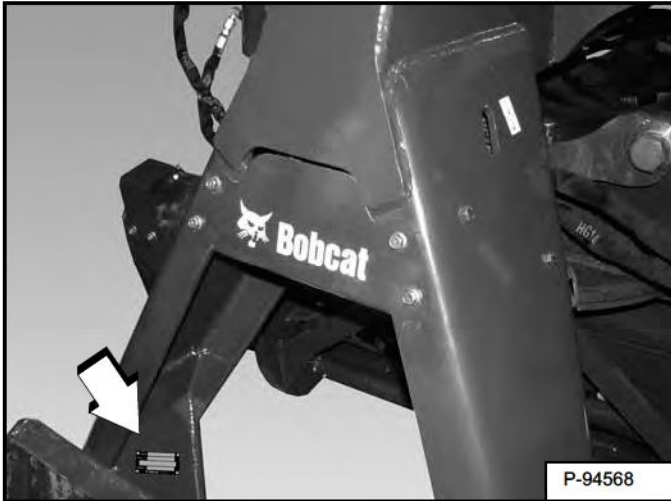

Always use the serial number [Figure 1] of the Bobcat grader when requesting service information or when ordering parts. Early or later models (identification made by serial number) may use different parts, or it may be necessary to use a different procedure in doing a specific service operation.

DELIVERY REPORT

Figure 2



The delivery report [Figure 2] must be completed by the dealer and signed by the owner or operator when the Bobcat grader is delivered. An explanation of the form must be given to the owner.

Dealer Copy -- Not for Resale

ATTACHMENT IDENTIFICATION

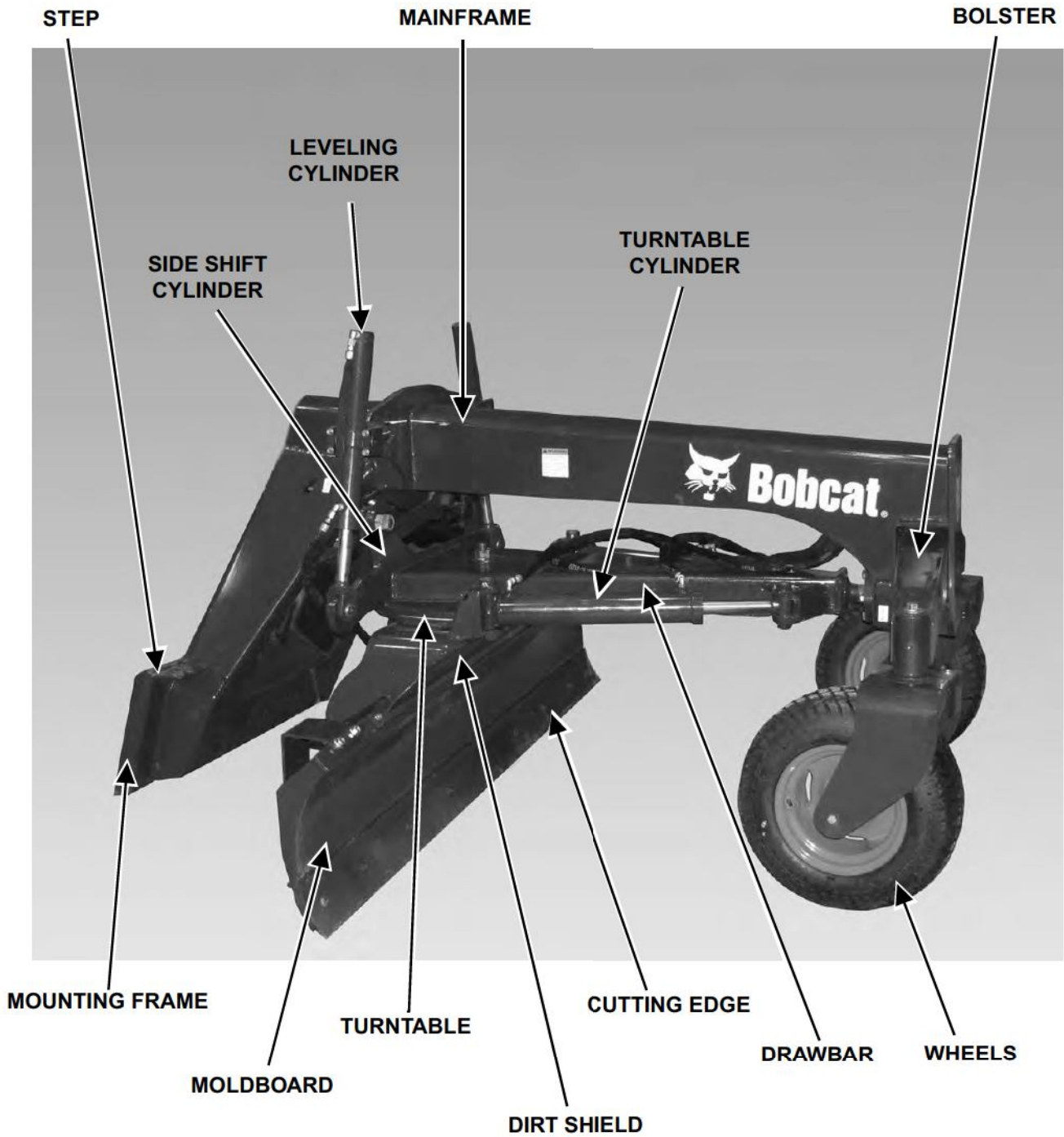

P-94266

Dealer Copy -- Not for Resale

SAFETY AND MAINTENANCE

TROUBLESHOOTING	10-10-1
Grader Chart	10-10-1
BLR2 Receiver Chart	10-10-2
Laser Beacon Chart	10-10-3
DAILY INSPECTION	10-20-1
Attachment Mounting Frame	10-20-1
Bob-Tach	10-20-2
LUBRICATING THE ATTACHMENT	10-30-1
Lubrication Locations	10-30-1
REGULAR MAINTENANCE ITEMS	10-40-1
Cutting Edge	10-40-1
Turntable Clamp Slide	10-40-1
Turntable Slide	10-40-1
Laser System	10-40-2
REMOVAL AND INSTALLATION OF CUTTING EDGE	10-50-1
Procedure	10-50-1
REMOVAL AND INSTALLATION OF TURNTABLE CLAMP	10-51-1
Procedure	10-51-1
REMOVAL AND INSTALLATION OF TURNTABLE WEAR SLIDE	10-52-1
Procedure	10-52-1
ATTACHMENT STORAGE AND RETURN TO SERVICE	10-60-1
Storage	10-60-1
Return To Service	10-60-1

Dealer Copy -- Not for Resale

TROUBLESHOOTING

Grader Chart

 WARNING	<p>Instructions are necessary before operating or servicing machine. Read and understand the Operation & Maintenance Manual, Operator's Handbook and signs (decals) on machine. Follow warnings and instructions in the manuals when making repairs, adjustments or servicing. Check for correct function after adjustments, repairs or service. Untrained operators and failure to follow instructions can cause injury or death.</p> <p style="text-align: right;">W-2003-0807</p>
--	--

If the grader is not working correctly, check the hydraulic system of the machine thoroughly before making any repairs on the grader. Grader problems can be affected by a hydraulic system that is not operating to specifications. Connect a flow meter to the machine to check the hydraulic pump output, relief valve setting and tube lines to check flow and pressure. (See the machine's Service Manual for the correct procedure to connect the flow meter.)

Use the following troubleshooting chart to locate and correct problems which most often occur with the attachment.

TROUBLESHOOTING THE GRADER		
PROBLEM	CAUSE	CORRECTION
Grader does not mount properly on the Bob-Tach™.	Bob-Tach wedges are not fully retracted prior to mounting.	Retract Bob-Tach wedges before installation.
	Mud, dirt or stones are lodged between the Bob-Tach and the grader mount.	Remove debris between Bob-Tach and grader mount.
Grader cut is not level.	Moldboard is not properly positioned.	Adjust moldboard to desired position.
	Cutting edge is worn.	Reverse cutting edge or install new cutting edge.
Grader blade does not maintain it's position.	Hydraulic cylinder has internal leakage.	Test and repair cylinder.
	Control valve has internal leakage.	Repair control valve.
Grader blade moves up and down uncontrollably.	Auxiliary flow is enabled and receiver is not properly connected.	Disable auxiliary flow and check receiver connection.
Grader blade will not angle, oscillate or side shift.	Electrical harness not connected.	Connect electrical harness.
	Wires disconnected or broken at control valve.	Repair or replace as needed.
	Control harness disconnected or damaged ACD control module.	Check harness and control module, repair or replace as needed.
Laser graded surface is uneven.	Excessive ground speed.	Drive slower.
	Receivers are not setup level on poles.	Adjust receivers. See Operation & Maintenance Manual.
NOTE: For other problems, see Operation & Maintenance Manual or contact your Bobcat Dealer.		

Dealer Copy -- Not for Resale

TROUBLESHOOTING (CONT'D)

BLR2 Receiver Chart

TROUBLESHOOTING THE BLR2 RECEIVER		
PROBLEM	CAUSE	CORRECTION
Unit will not turn on.	No power to the unit.	Make sure the system's Power Cable is connected to the machine's battery.
	Not enough power to the unit.	Make sure the machine has enough power (9V to 16V DC required).
	Receiver cable loose.	Make sure the receiver cable is secure at both ends.
	Bad fuse.	Check the fuse.
	Receiver cable is bad.	If you have a spare, try a different receiver cable.
Single green LED is lit and arrows flash alternately.	Receiver is seeing laser beacon but there's no CAN communication with ACD.	Check 9xxx (purple) wires for correct routing.
		Check 9xxx (purple) wires for pushed back terminals.
		Receiver is damaged, replace receiver.
All lights flash once and then go from bright to dim.	Ambient light sensor on receiver is damaged.	Replace receiver.
Auto light goes not respond to trigger when used with 7 pin connector.	No CAN communication between receiver and ACD.	Check 9xxx (purple) wires for correct routing.
		Check 9xxx (purple) wires for pushed back terminals.
		Receiver is damaged, replace receiver.
Arrows do not respond to laser beacon and single LED does a double flash once every two seconds.	Receiver is not detecting laser beacon.	Adjust laser beacon or receiver height to bring receiver within range.
		Make sure laser beacon is at least 3 m (10 ft) away from receiver.
Erratic display of arrows.	Receivers are not properly initialized.	Shut off carrier and restart.
	ACD harness damaged.	Replace the harness.
	Receiver harness damaged or not properly installed.	Check connections or replace harness as required.
	Valve harness has left and right receiver connection points swapped.	Swap valve harness receiver connection points. (Black tie strap / 'RIGHT' identification tag should be on the right side of frame as viewed from the operators position.)
Trimble Support Machine Control - Construction Instructions Americas: 1 - 800 - 538 - 7800 (Option 3 For Support) Outside Of Americas: 1 - 303 - 323 - 4111 E-Mail: Trimble_Support@Trimble.com		

Dealer Copy -- Not for Resale

TROUBLESHOOTING (CONT'D)

Laser Beacon Chart

TROUBLESHOOTING THE LASER BEACON		
PROBLEM	CAUSE	CORRECTION
Laser Beacon will not operate.	No power.	Press power button.
	Batteries are bad.	Check or replace batteries.
	Laser needs servicing.	Return laser to service center for inspection.
Laser Beacon out-of-level indicator does not shut off.	Laser not mounted securely.	Make sure the laser is mounted to stable surface.
	Laser in wrong mode.	Press the mode button so that the laser is in automatic self-leveling or grade mode.
	Leveling screws not turning.	Make sure the leveling screws are free to turn.
	Laser not level.	Allow the laser to re-level.
	Laser needs servicing.	Return laser to service center for inspection.
SafeGuard LED is on.	Calibration is off.	Check and adjust laser plane calibration as necessary.
	Laser needs servicing.	Return laser to service center for inspection.
Laser Beacon plane not accurate.	Calibration is off.	Check and adjust laser plane calibration as needed.
	Laser needs servicing.	Return laser to service center for inspection.
NOTE: For other problems related to the laser products, see Trimble Operation Manual or contact your Bobcat Dealer.		
Trimble Support Machine Control - Construction Instructions Americas: 1 - 800 - 538 - 7800 (Option 3 For Support) Outside Of Americas: 1 - 303 - 323 - 4111 E-Mail: Trimble_Support@Trimble.com		

Dealer Copy -- Not for Resale

DAILY INSPECTION

Attachment Mounting Frame

Figure 10-20-1

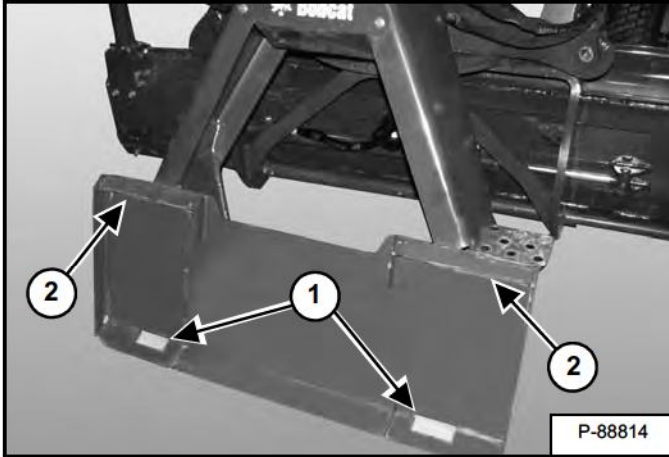

Inspect the Bob-Tach wedge mounts (Item 1), mounting flange (Item 2) [Figure 10-20-1] and all welds on the grader mount for wear and damage each time the grader is removed from the machine.

Frequently inspect the grader to ensure that all components are secure and that all bolts and nuts are thoroughly tightened.

DAILY INSPECTION (CONT'D)

Bob-Tach

Hand Lever Bob-Tach

! WARNING

AVOID INJURY OR DEATH

The Bob-Tach wedges must extend through the holes in the attachment mounting frame. Levers must be fully down and locked. Failure to secure wedges can allow attachment to come off.

W-2715-0208

Figure 10-20-2

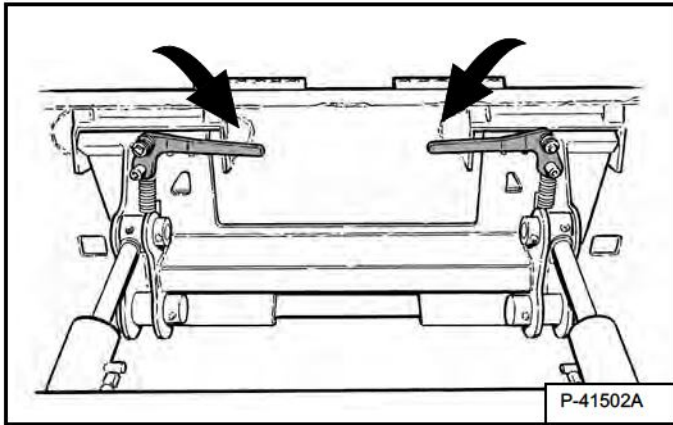

Push down on the Bob-Tach levers until they are fully engaged in the locked position [Figure 10-20-2] (wedges fully extended through the attachment mounting frame holes).

The levers and wedges must move freely [Figure 10-20-2].

Figure 10-20-3

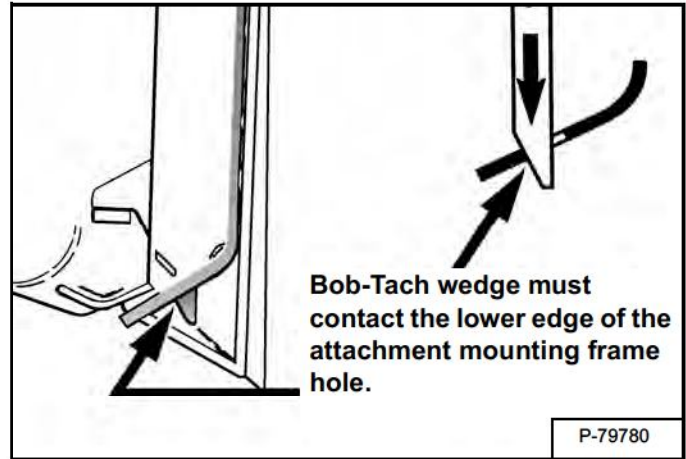

The wedges must extend through the holes in the attachment mounting frame, securely fastening the attachment to the Bob-Tach [Figure 10-20-3].

NOTE: If the wedge does not contact the lower edge of the hole, the attachment will be loose and can come off the Bob-Tach.

Inspect the mounting frame on the attachment. (See the machine's Operation & Maintenance Manual for inspecting the Bob-Tach). Replace any parts that are damaged, bent or missing. Keep all fasteners tight. Look for cracked welds. Contact your Bobcat dealer for repair or replacement parts.

Lubricate the wedges. (See the machine's Operation & Maintenance Manual for the correct procedure.)

DAILY INSPECTION (CONT'D)

Bob-Tach (Cont'd)

Power Bob-Tach

! WARNING

AVOID INJURY OR DEATH

The Bob-Tach wedges must extend through the holes in the attachment mounting frame. Levers must be fully down and locked. Failure to secure wedges can allow attachment to come off.

W-2715-0208

Figure 10-20-4

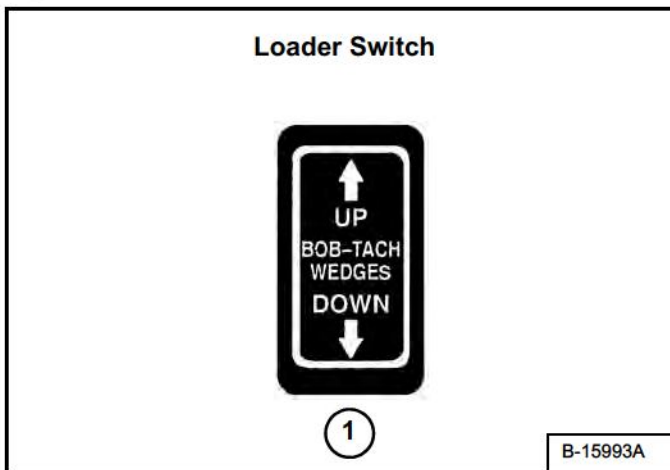
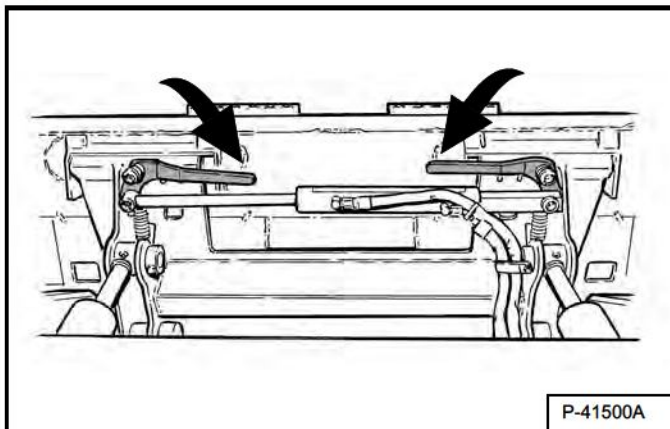
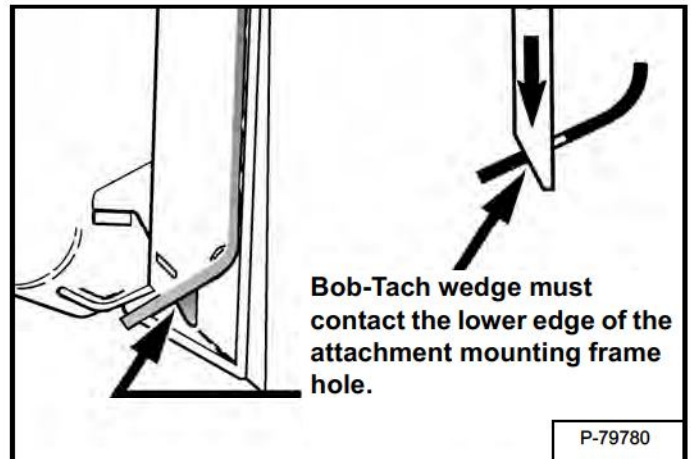

Figure 10-20-5



Push and hold the BOB-TACH “WEDGES DOWN” switch (Item 1) [Figure 10-20-4] and until the levers are fully engaged in the locked position [Figure 10-20-5] (wedges fully extended through the attachment mounting frame holes).

Figure 10-20-6



The wedges must extend through the holes in the attachment mounting frame, securely fastening the attachment to the Bob-Tach [Figure 10-20-6].

NOTE: If the wedge does not contact the lower edge of the hole, the attachment will be loose and can come off the Bob-Tach.

Inspect the mounting frame on the attachment. (See the machine's Operation & Maintenance Manual for inspecting the Bob-Tach). Replace any parts that are damaged, bent or missing. Keep all fasteners tight. Look for cracked welds. Contact your Bobcat dealer for repair or replacement parts.

Lubricate the wedges. (See the machine's Operation & Maintenance Manual for the correct procedure.)

Dealer Copy -- Not for Resale

LUBRICATING THE ATTACHMENT

Lubrication Locations

IMPORTANT

Fluid such as engine oil, hydraulic fluid, coolants, grease, etc. must be disposed of in an environmentally safe manner. Some regulations require that certain spills and leaks on the ground must be cleaned in a specific manner. See local, state and federal regulations for the correct disposal.

I-2067-0499

! WARNING

AVOID INJURY OR DEATH

Wear safety glasses to prevent eye injury when any of the following conditions exist:

- When fluids are under pressure.
- Flying debris or loose material is present.
- Engine is running.
- Tools are being used.

W-2019-0907

Always use a good quality lithium base multi purpose grease when lubricating the attachment. Apply lubricant until extra grease shows.

Lubricate the following every **8 - 10 hours**.

Figure 10-30-1

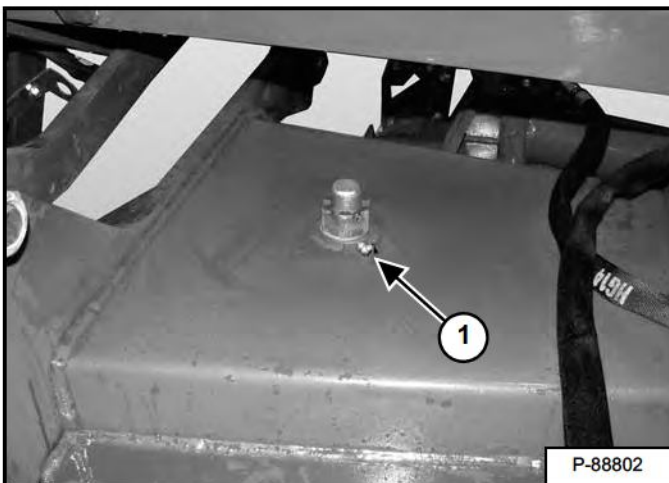

1. Turntable upper pivot (Item 1) [Figure 10-30-1].

Figure 10-30-2

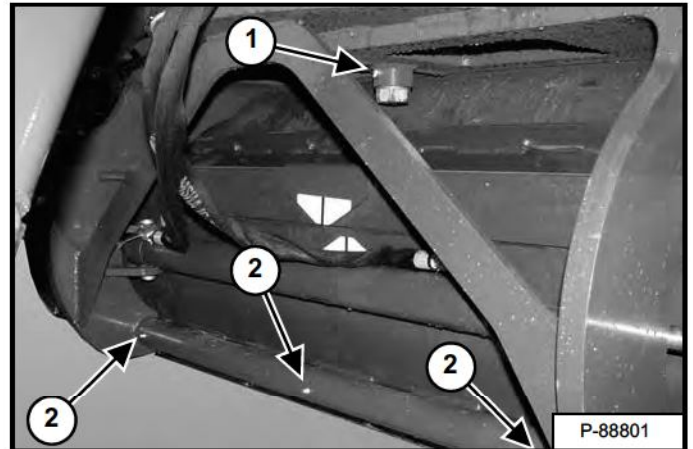

2. Moldboard hanger / turntable lower pivot (Item 1) [Figure 10-30-2].
3. Moldboard hanger, lower slide tube fittings (Item 2) [Figure 10-30-2].

Figure 10-30-3

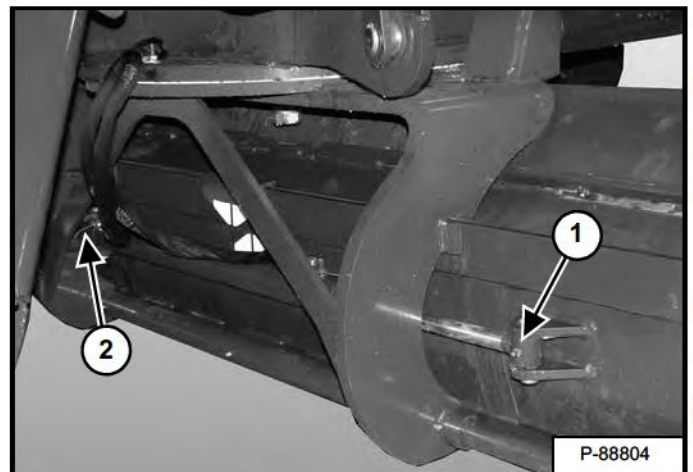

4. Moldboard side shift hydraulic cylinder rod end (Item 1) [Figure 10-30-3].
5. Moldboard side shift hydraulic cylinder base end (Item 2) [Figure 10-30-3].

Dealer Copy -- Not for Resale

LUBRICATING THE ATTACHMENT (CONT'D)

Lubrication Locations (Cont'd)

Figure 10-30-4

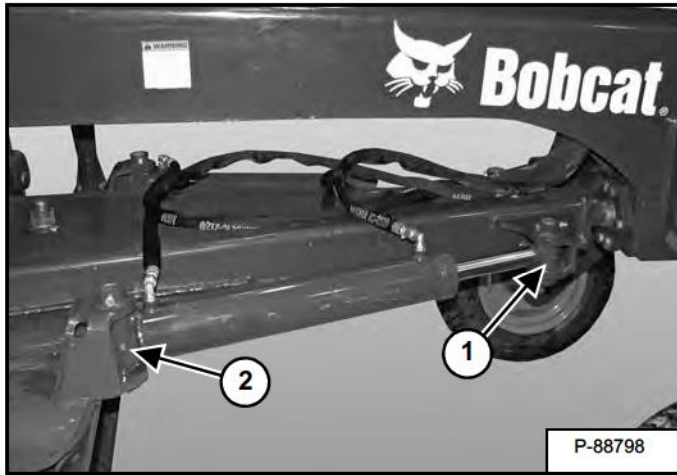

- 6. Moldboard angle hydraulic cylinder rod end (Both Sides) (Item 1) [Figure 10-30-4].
- 7. Moldboard angle hydraulic cylinder base end (Both Sides) (Item 2) [Figure 10-30-4].

Figure 10-30-5

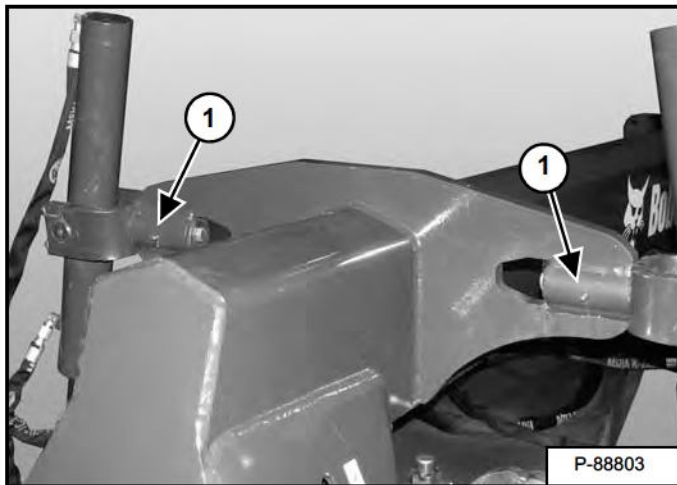

- 8. Moldboard elevation hydraulic cylinder mounts (Item 1) [Figure 10-30-5].

Figure 10-30-6

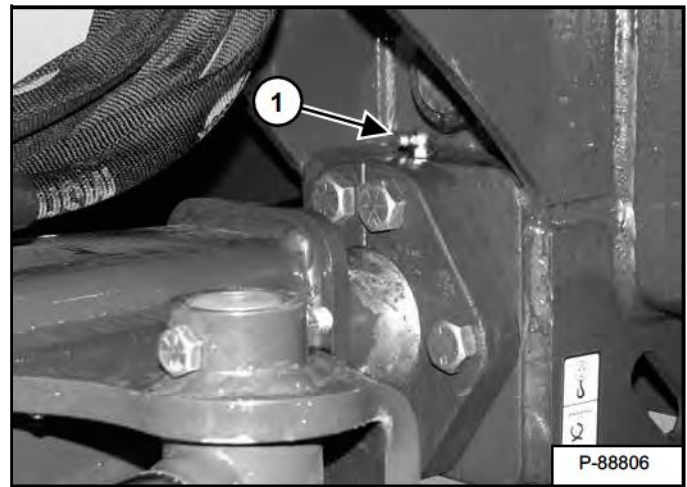

- 9. Drawbar front pivot mount (Item 1) [Figure 10-30-6].

Figure 10-30-7

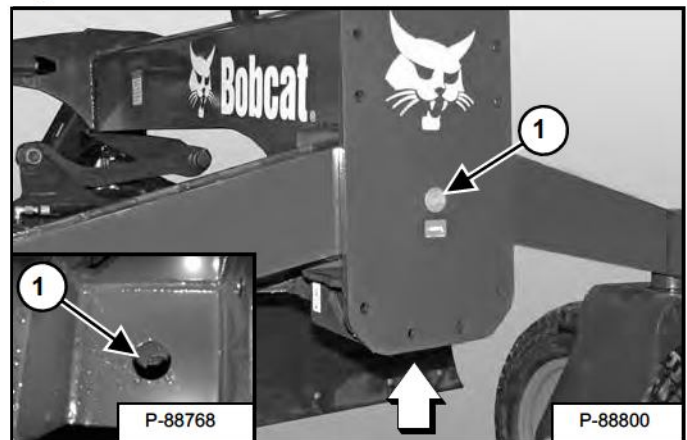

- 10. Bolster pivot pin (Both Locations) (Item 1) [Figure 10-30-7].

Dealer Copy -- Not for Resale

LUBRICATING THE ATTACHMENT (CONT'D)

Lubrication Locations (Cont'd)

Figure 10-30-8

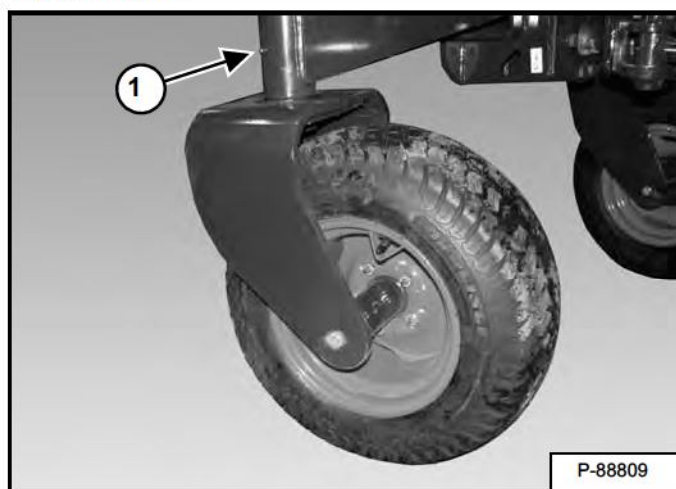

11. Caster Wheel Spindle (Both Sides) (Item 1) [Figure 10-30-8].



Suggest:

If the above button click is invalid.

Please download this document

first, and then click the above link

to download the complete manual.

Thank you so much for reading

REGULAR MAINTENANCE ITEMS

Cutting Edge



AVOID INJURY OR DEATH

Securely block up the attachment before working underneath.

W-2795-0409



AVOID INJURY OR DEATH

Wear safety glasses to prevent eye injury when any of the following conditions exist:

- When fluids are under pressure.
- Flying debris or loose material is present.
- Engine is running.
- Tools are being used.

W-2019-0907

Figure 10-40-1

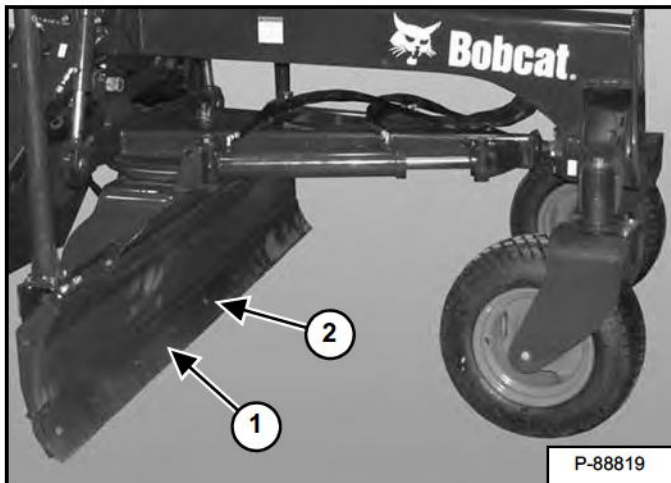

Inspect the cutting edge (Item 1), replace if any damage or excessive wear is visible. Tighten or replace any loose or missing bolts or nuts (Item 2) [Figure 10-40-1]. (See REMOVAL AND INSTALLATION OF CUTTING EDGE on Page 10-50-1.)

Turntable Clamp Slide

Figure 10-40-2

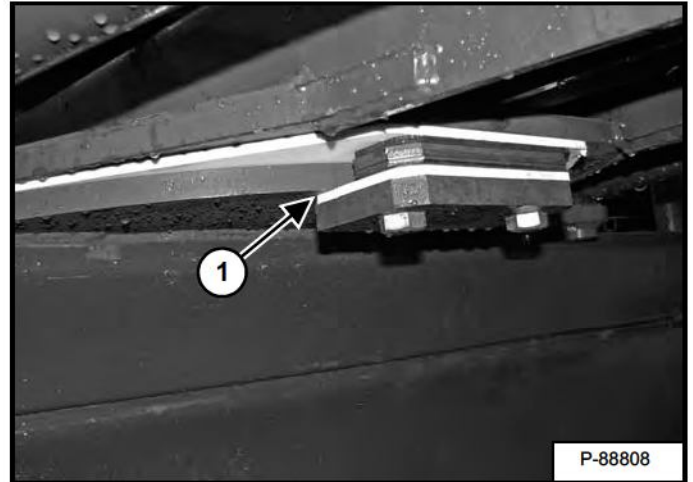

Check the turntable clamp slide (Item 1) [Figure 10-40-2], replace if any damage or excessive wear is visible. (See REMOVAL AND INSTALLATION OF TURNTABLE CLAMP on Page 10-51-1.)

Turntable Slide

Figure 10-40-3

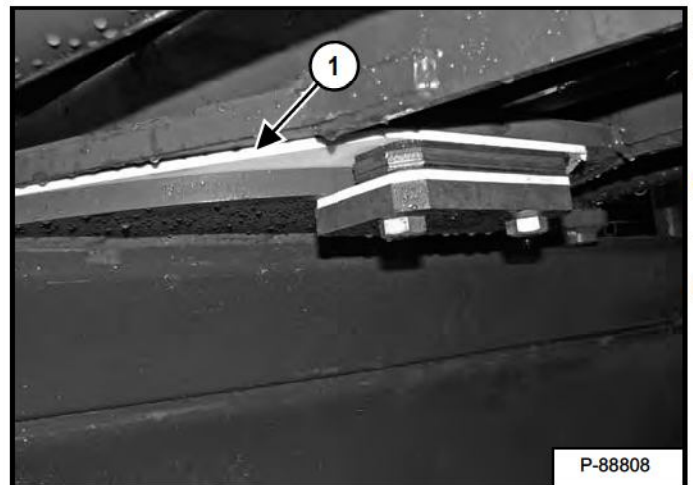

Check the turntable slide (Item 1) [Figure 10-40-3], replace if any damage or excessive wear is visible. (See REMOVAL AND INSTALLATION OF TURNTABLE WEAR SLIDE on Page 10-52-1.)

Dealer Copy -- Not for Resale

<https://www.ebooklibonline.com>

Hello dear friend!

Thank you very much for reading.

Enter the link into your browser.

The full manual is available for immediate download.

<https://www.ebooklibonline.com>