



Bobcat®

Service Manual Direct Drive Auger

Lowe

10 S/N 879900101 & Above
12 S/N 811800101 & Above
12 S/N 437500101 & Above
12H S/N 437100101 & Above
15 S/N 187400101 & Above
15C S/N 944200101 & Above
15H S/N 187500101 & Above
15H S/N A90L00101 & Above

18 S/N 811100101 & Above
18H S/N 811700101 & Above
20 S/N 856300101 & Above
20H S/N 438300101 & Above
30 S/N 187600101 & Above
30C S/N 944500101 & Above
30H S/N 187700101 & Above
30H S/N A7ER00101 & Above

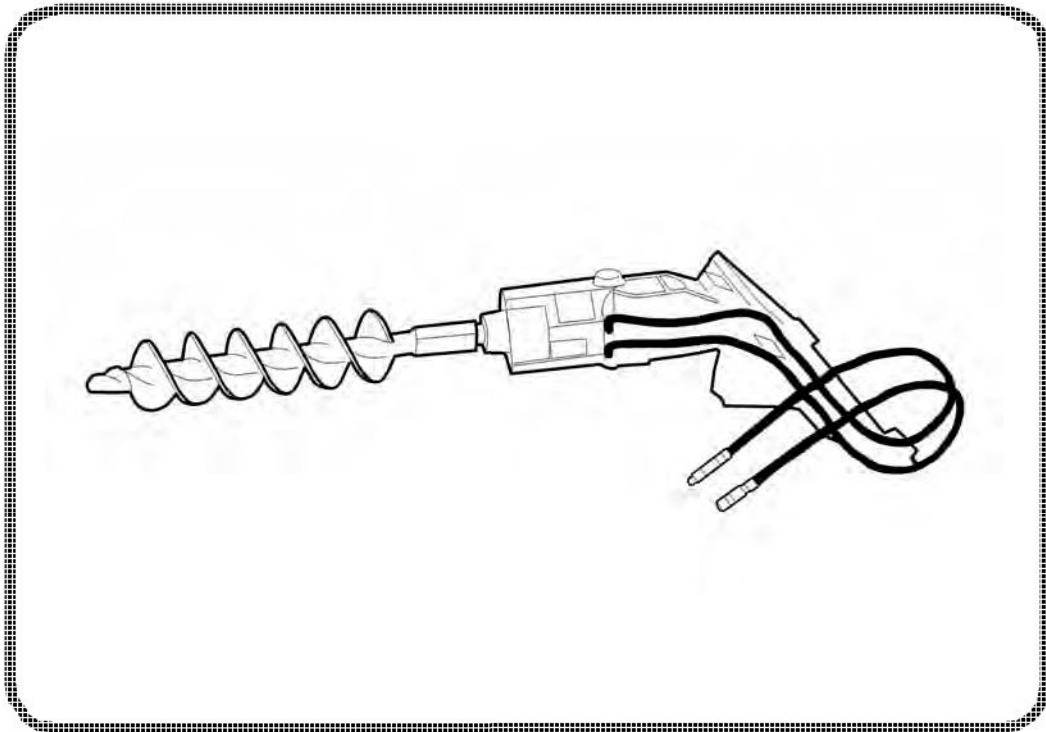

Doosan purchased Bobcat Company from Ingersoll-Rand Company in 2007. Any reference to Ingersoll-Rand Company or use of trademarks, service marks, logos, or other proprietary identifying marks belonging to Ingersoll-Rand Company in this manual is historical or nominative in nature, and is not meant to suggest a current affiliation between Ingersoll-Rand Company and Bobcat Company or the products of either.



MAINTENANCE SAFETY



WARNING







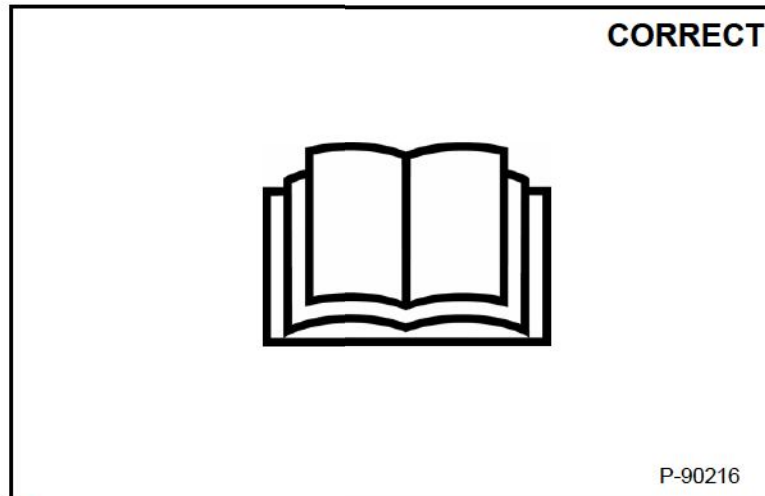

Instructions are necessary before operating or servicing machine. Read and understand the Operation & Maintenance Manual, Operator's Handbook and signs (decals) on machine. Follow warnings and instructions in the manuals when making repairs, adjustments or servicing. Check for correct function after adjustments, repairs or service. Untrained operators and failure to follow instructions can cause injury or death.

W-2003-0807



Safety Alert Symbol: This symbol with a warning statement, means: "Warning, be alert! Your safety is involved!" Carefully read the message that follows.



-  Never service attachments / implements without instructions. See Operation & Maintenance Manual and Attachment / Implement Service Manual.
-  Cleaning and maintenance are required daily.
-  Never service or adjust attachment / implement with the engine running unless instructed to do so in manual.
-  Always lower the attachment / implement to the ground before lubricating or servicing.
-  Avoid contact with leaking hydraulic fluid or diesel fuel under pressure. It can penetrate skin or eyes.
-  Stop, cool and clean engine of flammable materials before checking fluids.
-  Keep body, loose objects and clothing away from moving parts, electrical contacts, hot parts and exhaust.
-  Safety glasses are needed for eye protection from electrical arcs, battery acid, compressed springs, fluids under pressure and flying debris or when tools are used. Use eye protection approved for type of welding.

Dealer Copy -- Not for Resale

MSW30-0409

CONTENTS

SAFETY & MAINTENANCE	10-01
HYDRAULIC SYSTEM	20-01
MAINFRAME	30-01
ALPHABETICAL INDEXINDEX-01

Dealer Copy -- Not for Resale

FOREWORD

SERIAL NUMBER LOCATION	1-7
Attachment Serial Number	1-7
DELIVERY REPORT	1-7
ATTACHMENT IDENTIFICATION	1-8

<https://www.ebooklibonline.com>

Hello dear friend!

Thank you very much for reading.

Enter the link into your browser.

The full manual is available for immediate download.

<https://www.ebooklibonline.com>

SERIAL NUMBER LOCATION

Attachment Serial Number

Figure 1

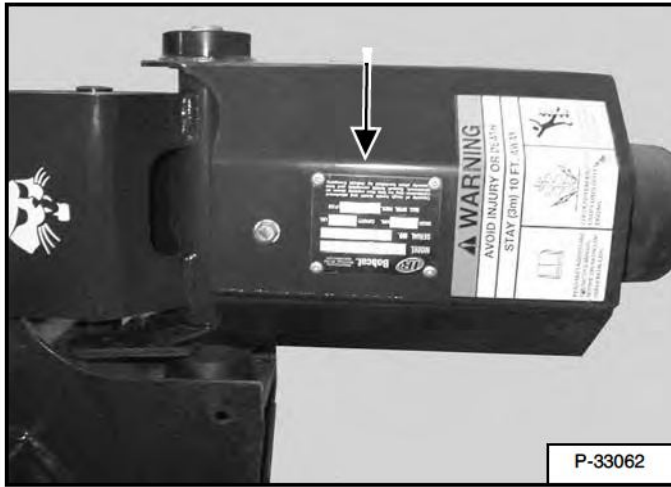

Always use the serial number of the direct drive auger when requesting service information or when ordering parts. Early or later models (identification made by serial number) may use different parts, or it may be necessary to use a different procedure in doing a specific service operation [Figure 1].

DELIVERY REPORT

Figure 2

The delivery report [Figure 2] must be completed by the dealer and signed by the owner or operator when the Bobcat direct drive auger is delivered. An explanation of the form must be given to the owner.

ATTACHMENT IDENTIFICATION

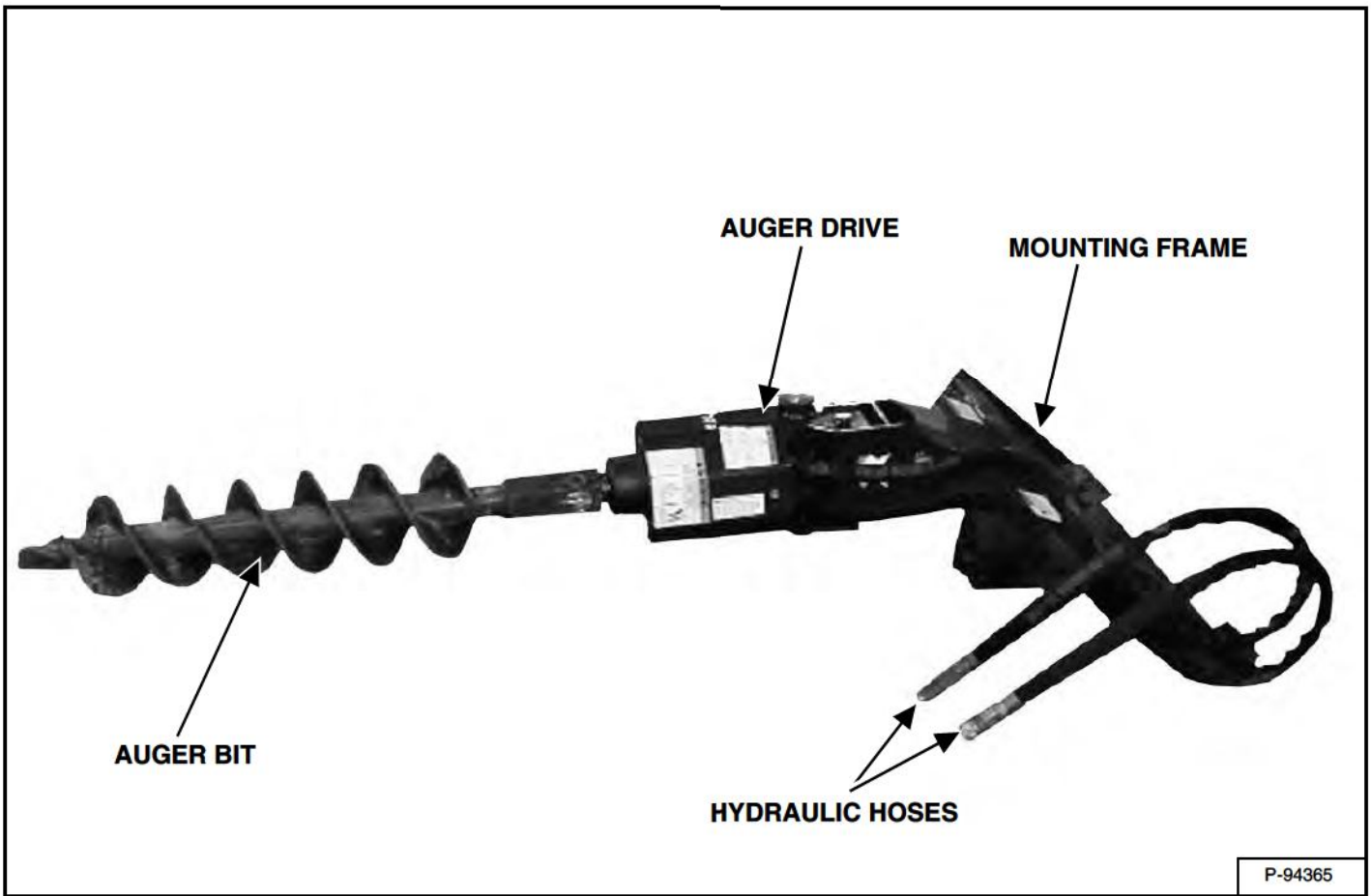

Dealer Copy -- Not for Resale

SAFETY & MAINTENANCE

TROUBLESHOOTING	10-10-1
Chart	10-10-1
DAILY INSPECTION	10-20-1
Attachment Mounting Frame	10-20-1
Bob-Tach	10-20-1
X-Change	10-20-3
Pin-On Attachment	10-20-4
LUBRICATING THE ATTACHMENT	10-30-1
Lubrication Locations	10-30-1
REMOVAL AND INSTALLATION	10-40-1
Auger Teeth	10-40-1

TROUBLESHOOTING

Chart

 WARNING	<p>Instructions are necessary before operating or servicing machine. Read and understand the Operation & Maintenance Manual, Operator's Handbook and signs (decals) on machine. Follow warnings and instructions in the manuals when making repairs, adjustments or servicing. Check for correct function after adjustments, repairs or service. Untrained operators and failure to follow instructions can cause injury or death.</p> <p style="text-align: right;">W-2003-0903</p>
--	--

If the attachment is not working correctly, check the hydraulic system of the machine thoroughly before making any repairs on the attachment. Attachment problems can be affected by a hydraulic system that is not operating to specifications. Connect a flow meter to the machine to check the hydraulic pump output, relief valve setting and tube lines to check flow and pressure. (See the machine's Service Manual for the correct procedure to connect the flow meter.)

Use the following troubleshooting chart to locate and correct problems which most often occur with the attachment.

PROBLEM	CAUSE	CORRECTION
Auger does not mount properly on the Bob-Tach.	Bob-Tach wedges are not fully retracted.	Retract Bob-Tach wedges.
	Mud, dirt or stones are lodged between the Bob-Tach and the auger mount.	Remove debris from between Bob-Tach and auger mount.
Auger does not rotate.	No hydraulic flow.	Activate loader front auxiliary hydraulics. Check quick couplers connection. Check for damaged hose ends and fittings.
	Auger pin missing or broken.	Replace auger pin.
	Chain or sprockets worn or damaged (12, 12H, 18, 18H, 20 and 20H only)	Replace chain and/or sprockets.
	Worn or damaged key on hydraulic motor shaft (12, 12H, 18, 18H, 20 and 20H only)	Replace key.
Auger does not dig efficiently.	Worn or damaged auger teeth.	Replace teeth.

Dealer Copy -- Not for Resale

DAILY INSPECTION

Attachment Mounting Frame

Figure 10-20-1

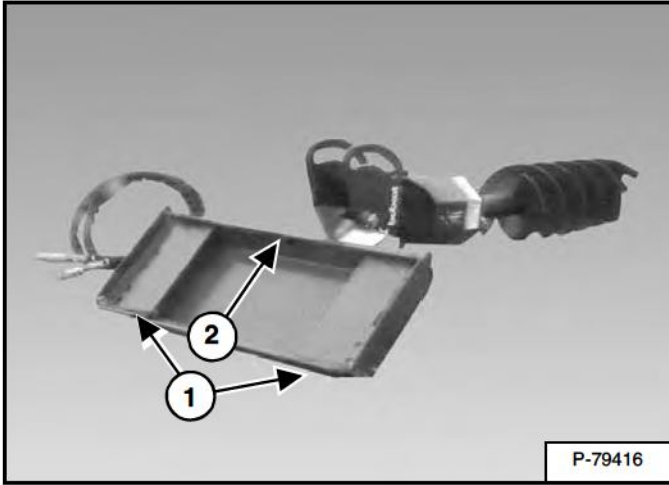

Inspect the Bob-Tach wedge mounts (Item 1), mounting flange (Item 2) [Figure 10-20-1] and all welds on the direct drive auger for wear and damage each time the auger is removed from the loader.

Bob-Tach

Hand Lever Bob-Tach



AVOID INJURY OR DEATH

The Bob-Tach wedges must extend through the holes in the attachment mounting frame. Levers must be fully down and locked. Failure to secure wedges can allow attachment to come off.

W-2715-0208

Figure 10-20-2

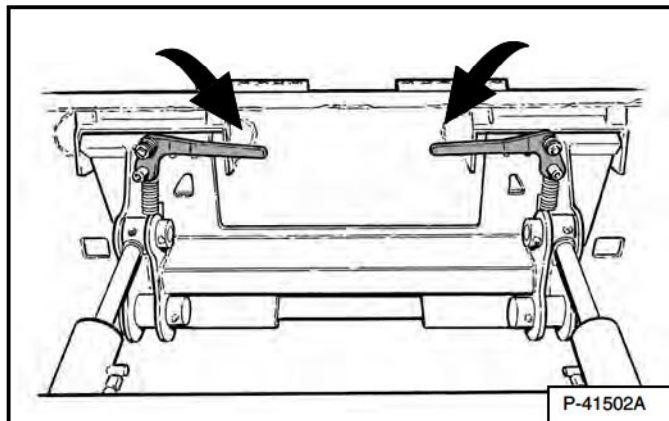

Push down on the Bob-Tach levers until they are fully engaged in the locked position [Figure 10-20-2] (wedges fully extended through the attachment mounting frame holes).

The levers and wedges must move freely [Figure 10-20-2].

Figure 10-20-3

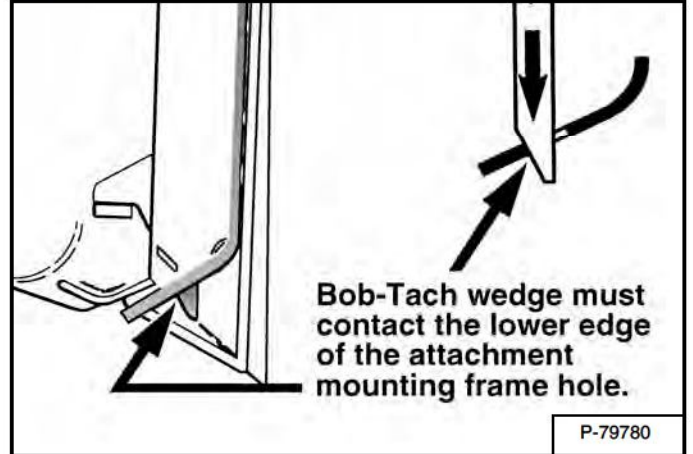

The wedges must extend through the holes in the attachment mounting frame, securely fastening the attachment to the Bob-Tach [Figure 10-20-3].

NOTE: If the wedge does not contact the lower edge of the hole, the attachment will be loose and can come off the Bob-Tach.

Inspect the mounting frame on the attachment. (See the machine's Operation and Maintenance Manual for inspecting the Bob-Tach). Replace any parts that are damaged, bent or missing. Keep all fasteners tight. Look for cracked welds. Contact your Bobcat dealer for repair or replacement parts.

Lubricate the wedges. (See the machine's Operation & Maintenance Manual for the correct procedure.)

DAILY INSPECTION (CONT'D)

Bob-Tach (Cont'd)

Power Bob-Tach

! WARNING

AVOID INJURY OR DEATH

The Bob-Tach wedges must extend through the holes in the attachment mounting frame. Levers must be fully down and locked. Failure to secure wedges can allow attachment to come off.

W-2715-0208

Figure 10-20-4

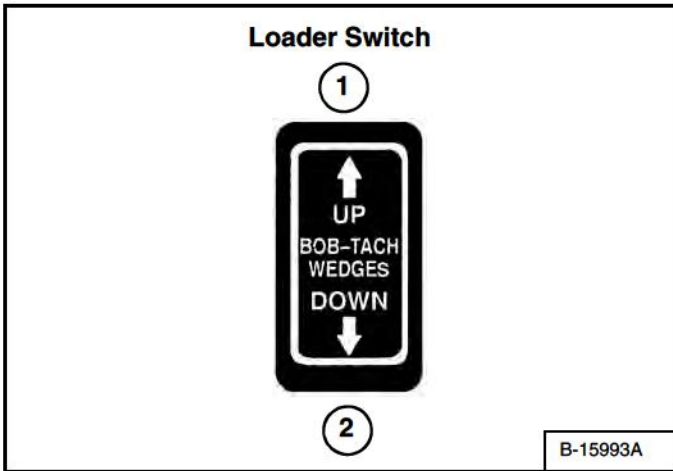

Figure 10-20-5

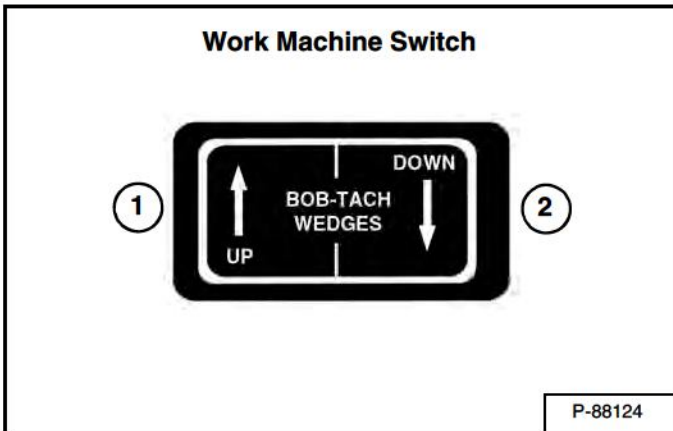
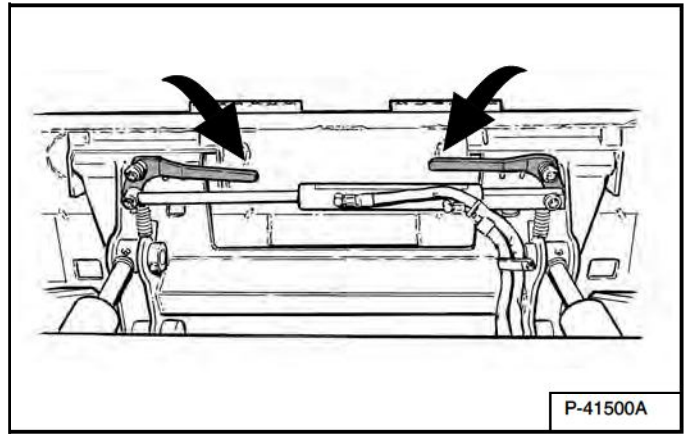
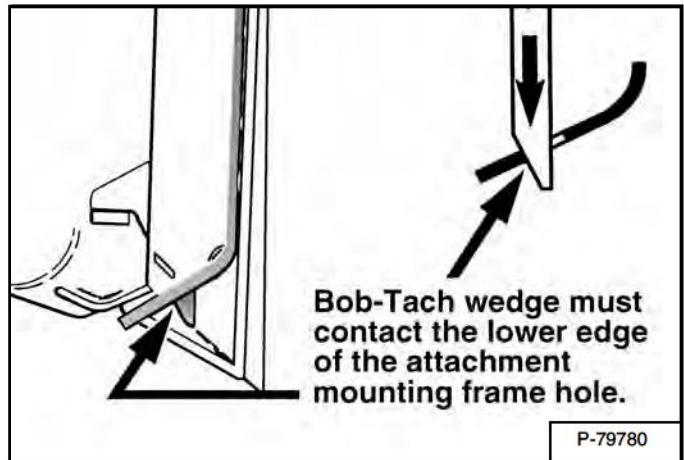

Figure 10-20-6



Push and hold the BOB-TACH “WEDGES DOWN” switch (Item 2) [Figure 10-20-4] and [Figure 10-20-5] until the levers are fully engaged in the locked position [Figure 10-20-6] (wedges fully extended through the attachment mounting frame holes).

Figure 10-20-7



The wedges must extend through the holes in the attachment mounting frame, securely fastening the attachment to the Bob-Tach [Figure 10-20-7].

NOTE: If the wedge does not contact the lower edge of the hole, the attachment will be loose and can come off the Bob-Tach.

Inspect the mounting frame on the attachment. (See the machine's Operation and Maintenance Manual for inspecting the Bob-Tach). Replace any parts that are damaged, bent or missing. Keep all fasteners tight. Look for cracked welds. Contact your Bobcat dealer for repair or replacement parts.

Lubricate the wedges. (See the machine's Operation & Maintenance Manual for the correct procedure.)

DAILY INSPECTION (CONT'D)

X-Change

Hydraulic X-Change

Figure 10-20-8

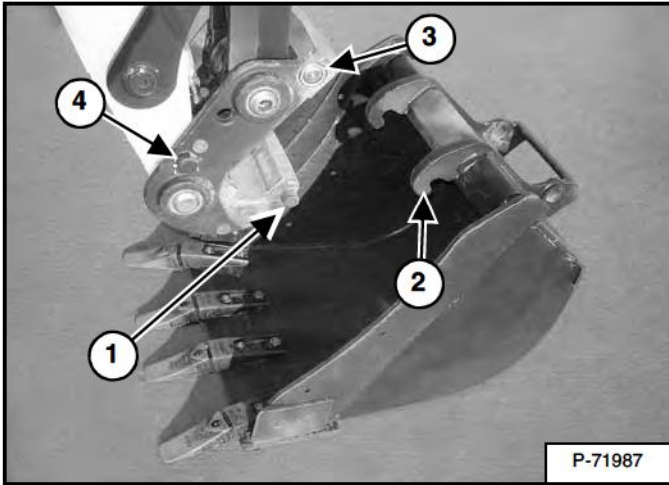

Inspect the X-Change for wear or damage. Inspect the X-Change pins (Item 1) and hooks (Item 2) [Figure 10-20-8] (on the attachment) for wear or damage.

Inspect the hydraulic pins (Item 3) [Figure 10-20-8] (both sides) for wear or damage.

Inspect the retainer pin and clips (Item 4) [Figure 10-20-8] (both sides) for wear or damage. **ONLY USE APPROVED RETAINER PINS AND CLIPS.**

Repair or replace damaged or missing parts.

Pin-On X-Change

Figure 10-20-9

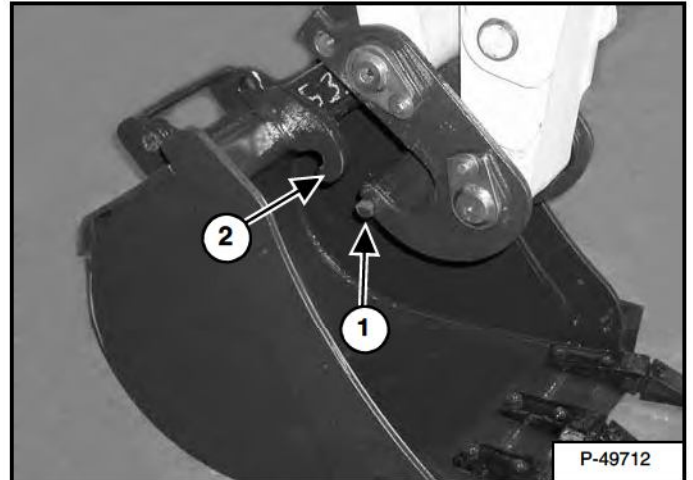

Inspect the X-Change for wear or damage. Inspect the X-Change pins (Item 1) and hooks (Item 2) [Figure 10-20-9] (on the attachment) for wear or damage.

Repair or replace damaged parts.

Figure 10-20-10

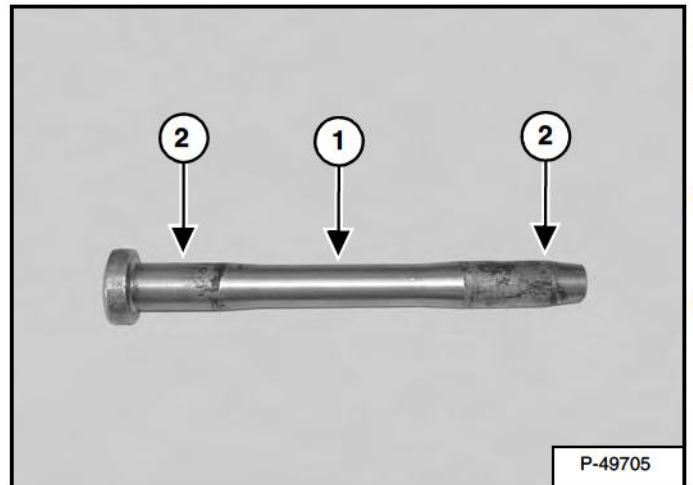

Inspect the pin (Item 1) [Figure 10-20-10] for wear or damage. Replace the pin as needed.

Apply a light coat of grease to the ends of the pin (Item 2) [Figure 10-20-10].

Dealer Copy -- Not for Resale

DAILY INSPECTION (CONT'D)

X-Change (Cont'd)

Bolt-On X-Change

Figure 10-20-11

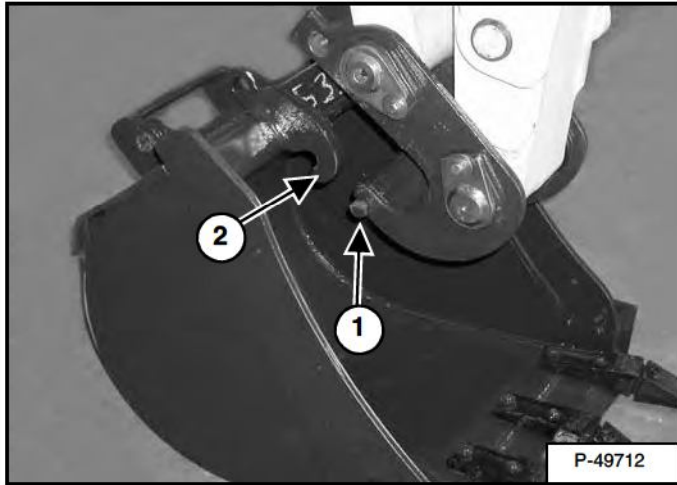

Inspect the X-Change for wear or damage. Inspect the X-Change pins (Item 1) and hooks (Item 2) [Figure 10-20-11] (on the attachment) for wear or damage.

Repair or replace damaged parts.

Figure 10-20-12

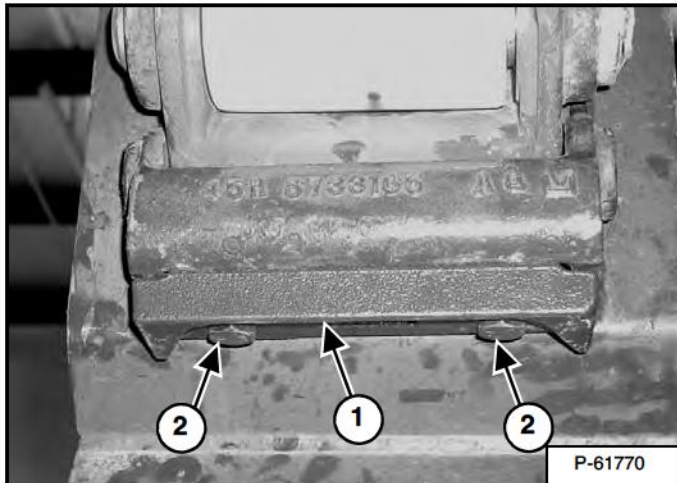

Check the plate (Item 1) for any wear or damage. Retorque the bolts (Item 2) [Figure 10-20-12] to 125 - 140 ft.-lb. (170 - 190 N•m) after every eight hours of operation.

Repair or replace damaged parts.

Pin-On Attachment

Figure 10-20-13

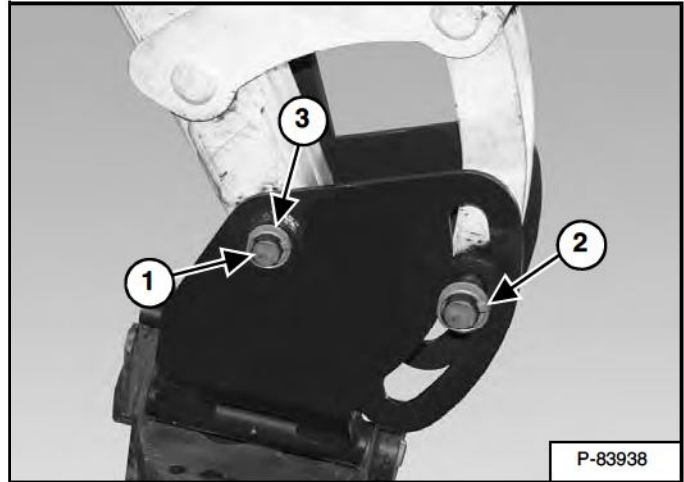

Inspect the coupler for wear or damage. Inspect the pins (Item 1), retaining pins (Item 2) and washers (Item 3) [Figure 10-20-13] (on the attachment) for wear or damage.

Repair or replace damaged parts.

LUBRICATING THE ATTACHMENT

Lubrication Locations

Always use a good quality lithium base multi purpose grease when lubricating the attachment. Apply lubricant until extra grease shows.

IMPORTANT

Fluid such as engine oil, hydraulic fluid, coolants, grease, etc. must be disposed of in an environmentally safe manner. Some regulations require that certain spills and leaks on the ground must be cleaned in a specific manner. See local, state and federal regulations for the correct disposal.

I-2067-0499

Figure 10-30-1

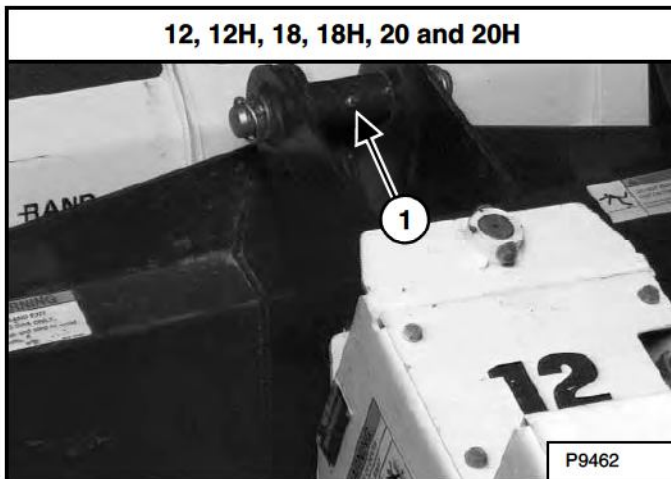

Lubricate the grease fitting (Item 1) [Figure 10-30-1] every 8 hours using a good quality lithium based multi-purpose grease.

Put a good grade of chain lubricant on the chain after every 50 hours of operation.

Figure 10-30-2

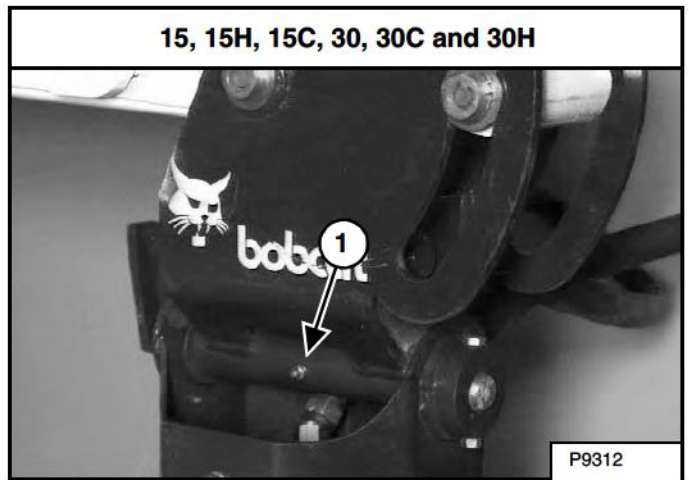

The excavator mounted auger has one grease fitting (Item 1) [Figure 10-30-2].

Lubricate the grease fitting every 8 hours using a good quality lithium based multi-purpose grease.

Figure 10-30-3

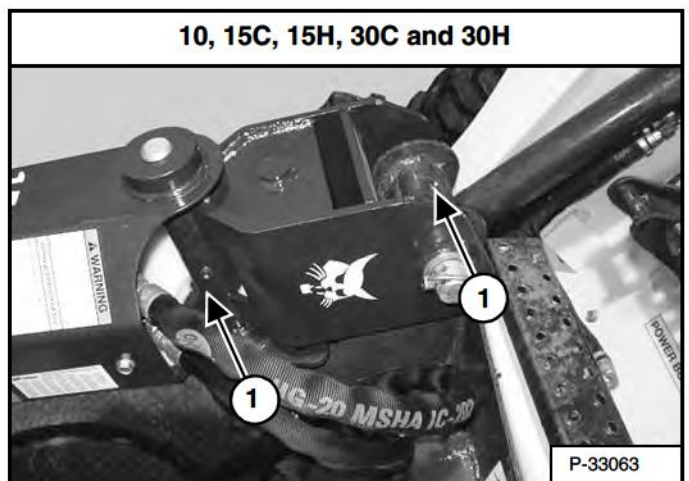

The loader mounted auger has two grease fittings.

Lubricate the two grease fittings (Item 1) [Figure 10-30-3] every 8 hours using a good quality lithium based multi-purpose grease.

! WARNING

AVOID INJURY OR DEATH

Wear safety glasses to prevent eye injury when any of the following conditions exist:

- When fluids are under pressure.
- Flying debris or loose material is present.
- Engine is running.
- Tools are being used.

W-2019-0907

Dealer Copy -- Not for Resale



Suggest:

If the above button click is invalid.

Please download this document

first, and then click the above link

to download the complete manual.

Thank you so much for reading

REMOVAL AND INSTALLATION

Auger Teeth

Auger Teeth (Bolted)

! WARNING

AVOID INJURY OR DEATH

Wear safety glasses to prevent eye injury when any of the following conditions exist:

- When fluids are under pressure.
- Flying debris or loose material is present.
- Engine is running.
- Tools are being used.

W-2019-0907

Replace the bolted auger teeth as follows:

Figure 10-40-1

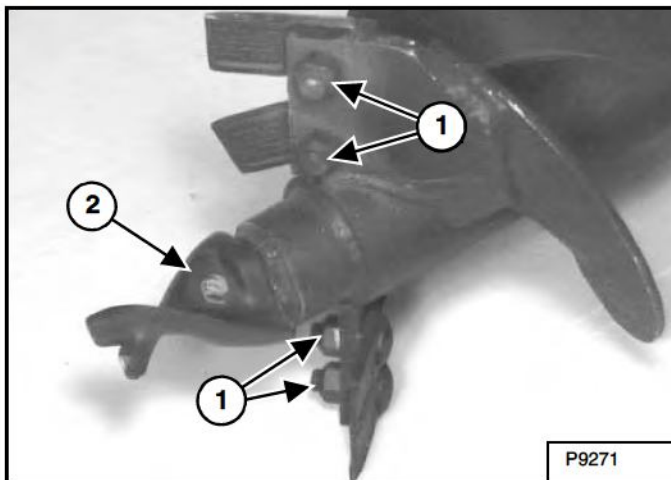

Remove the nuts and bolts (Item 1) [Figure 10-40-1]. Replace the nuts and bolts when replacing teeth.

Remove the nut and bolt (Item 2) [Figure 10-40-1] to replace the point tooth. Replace the nut and bolt when replacing the tooth.

Auger Teeth (Rubber Mounted)

Replace the rubber mounted auger teeth as follows;

Figure 10-40-2

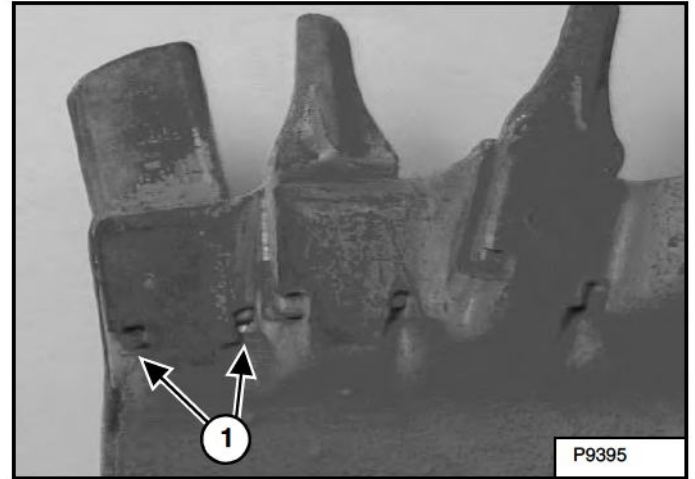

Use a punch and a hammer to drive the tooth out of the holder. Each tooth has two holes (Item 1) [Figure 10-40-2] for removal.

Figure 10-40-3

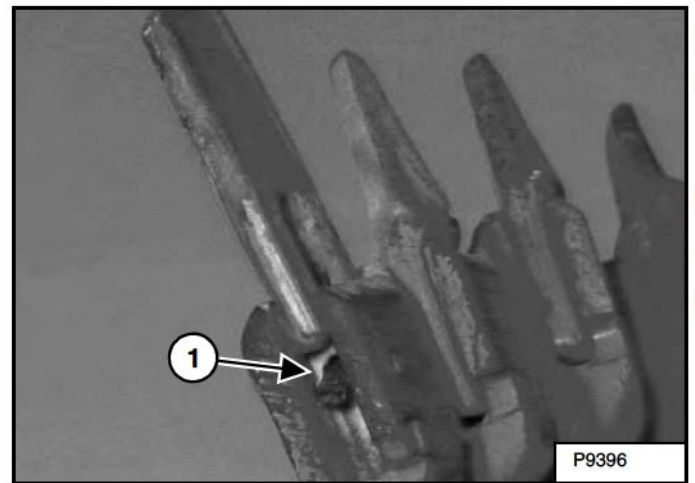

Check the condition of the rubber cord (Item 1) [Figure 10-40-3]. Replace as needed.

Install the tooth and use a rubber hammer to drive the teeth into position.

Dealer Copy -- Not for Resale

<https://www.ebooklibonline.com>

Hello dear friend!

Thank you very much for reading.

Enter the link into your browser.

The full manual is available for immediate download.

<https://www.ebooklibonline.com>