



Bobcat®

Cutter Crusher

Model 30
Model 40

Service Manual

Model 30 – S/N 991100101 & Above
Model 40 – S/N 991300101 & Above

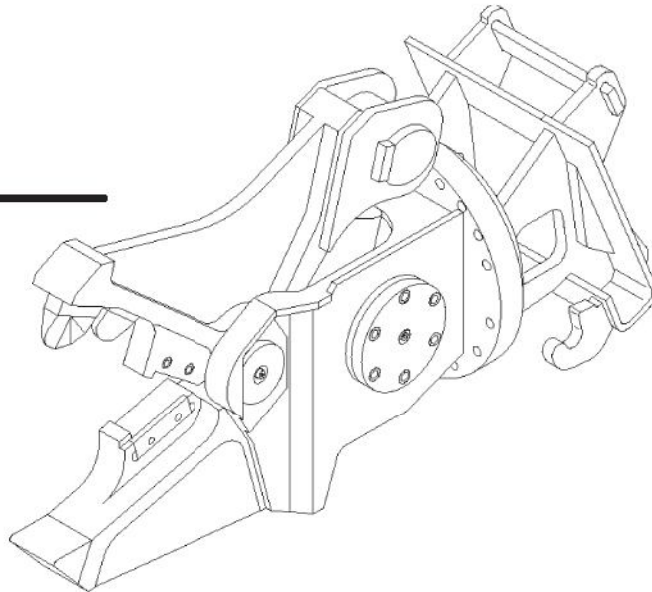

Dealer Copy - Not for Resale

Doosan purchased Bobcat Company from Ingersoll-Rand Company in 2007. Any reference to Ingersoll-Rand Company or use of trademarks, service marks, logos, or other proprietary identifying marks belonging to Ingersoll-Rand Company in this manual is historical or nominative in nature, and is not meant to suggest a current affiliation between Ingersoll-Rand Company and Bobcat Company or the products of either.



Hello

Thank you very much for your download.

In the last page of this PDF document.

There is a link.

Please click on that link and return to our website.

Then you can get the complete manual immediately.

No need to wait.

Thanks for continuing to read the documentation.

Best wishes.

MAINTENANCE SAFETY



WARNING







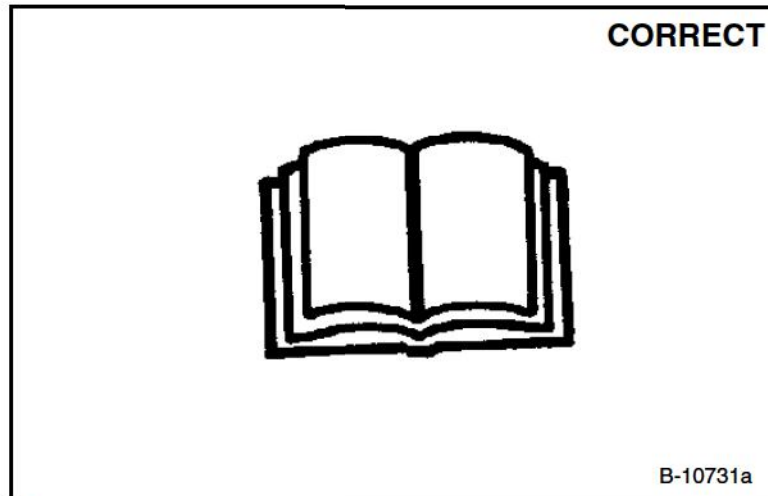

Instructions are necessary before operating or servicing machine. Read and understand the Operation & Maintenance Manual, Operator's Handbook and signs (decals) on machine. Follow warnings and instructions in the manuals when making repairs, adjustments or servicing. Check for correct function after adjustments, repairs or service. Untrained operators and failure to follow instructions can cause injury or death.

W-2003-0903



Safety Alert Symbol: This symbol with a warning statement, means: "Warning, be alert! Your safety is involved!" Carefully read the message that follows.



-  Never service attachments without instructions. See Operation & Maintenance Manual and Attachment Service Manual.
-  Cleaning and maintenance are required daily.
-  Never service or adjust attachment with the engine running unless instructed to do so in manual.
-  Always lower the attachment to the ground before lubricating or servicing.
-  Avoid contact with leaking hydraulic fluid or diesel fuel under pressure. It can penetrate skin or eyes.
-  Stop, cool and clean engine of flammable materials before checking fluids.
-  Keep body, loose objects and clothing away from moving parts, electrical contacts, hot parts and exhaust.
-  Safety glasses are needed for eye protection from electrical arcs, battery acid, compressed springs, fluids under pressure and flying debris or when tools are used. Use eye protection approved for type of welding.

ALPHABETICAL INDEX

CRUSHER TEETH REPLACEMENT	10-01
CUTTER CRUSHER (MODEL 30)	30-01
CUTTER CRUSHER (MODEL 40)	30-01
CUTTING BLADES	10-01
GLOSSARY OF HYDRAULIC SYMBOLS	40-01
HARD-SURFACING WEAR AREAS	10-01
HYDRAULIC CYLINDER (MODEL 30)	20-01
HYDRAULIC CYLINDER (MODEL 40)	20-01
HYDRAULIC SCHEMATIC (MODEL 30/40)	40-01
INSPECTION	10-01
LUBRICATION	10-01
PARTS IDENTIFICATION	iv
SERIAL NUMBER LOCATION	iii
SPECIFICATIONS (MODEL 30)	40-01
SPECIFICATIONS (MODEL 40)	40-01
TROUBLESHOOTING	10-01
WELDING TEMPLATE INFORMATION	10-01

<https://www.ebooklibonline.com>

Hello dear friend!

Thank you very much for reading.

Enter the link into your browser.

The full manual is available for immediate download.

<https://www.ebooklibonline.com>

CONTENTS

SERIAL NUMBER LOCATION	iii
PARTS IDENTIFICATION	v
SAFETY AND MAINTENANCE	10-01
HYDRAULIC SYSTEM	20-01
MAIN FRAME	30-01
SPECIFICATIONS AND SCHEMATICS	40-01

**SAFETY AND
MAINTENANCE**

**HYDRAULIC
SYSTEM**

**MAIN
FRAME**

**SPECIFICATIONS
AND
SCHEMATICS**

**CALIFORNIA
PROPOSITION 65 WARNING**

Diesel engine exhaust and some of its constituents are known to the State of California to cause cancer, birth defects and other reproductive harm.

Dealer Copy -- Not for Resale

SERIAL NUMBER LOCATION

Always use the serial number of the Cutter Crusher when requesting service information or when ordering parts. Early or later models (identification made by serial number) may use different parts, or it may be necessary to use a different procedure in doing a specific service operation [A].

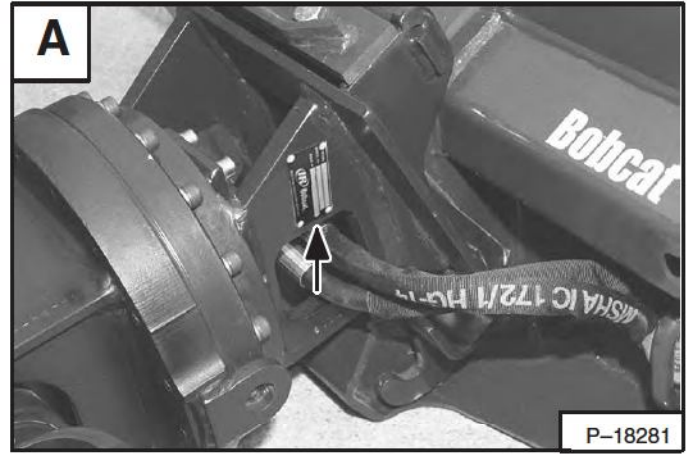

Dealer Copy -- Not for Resale

PARTS IDENTIFICATION

Loader Mount

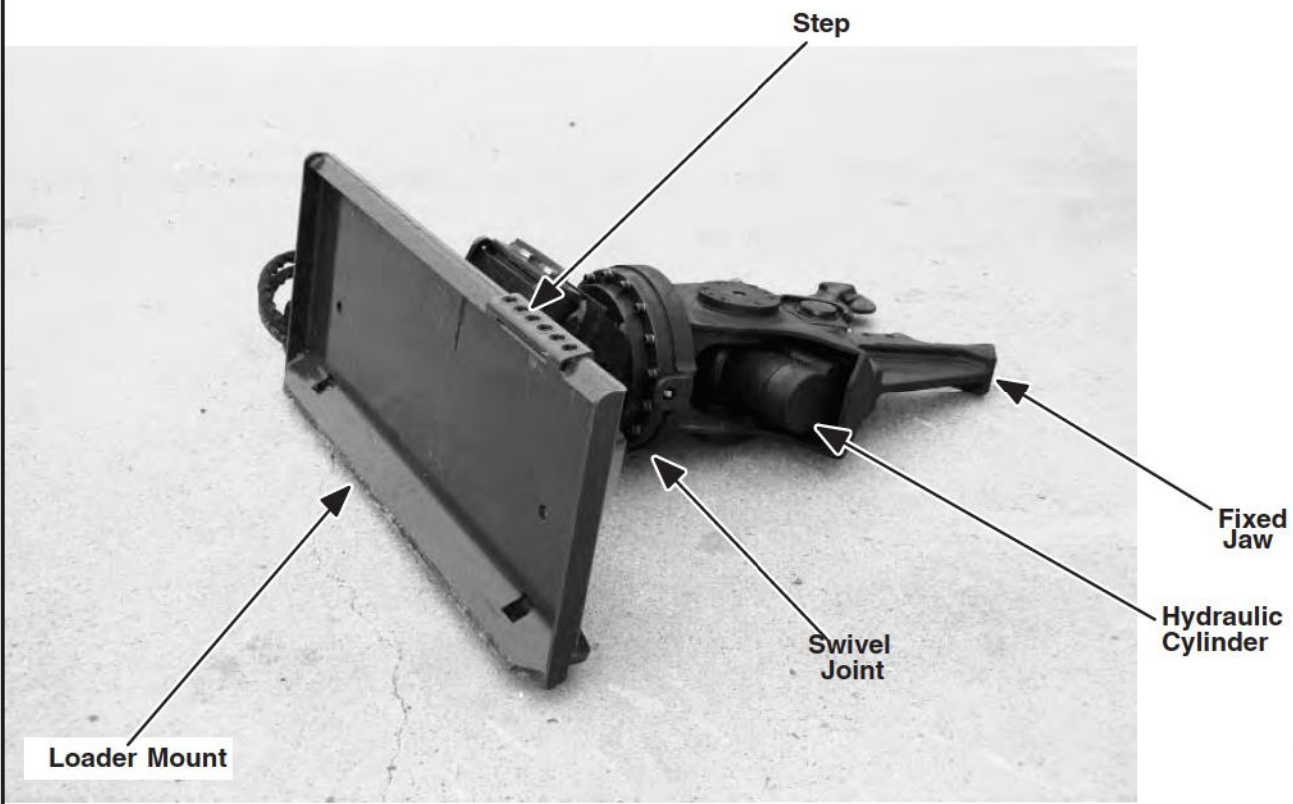
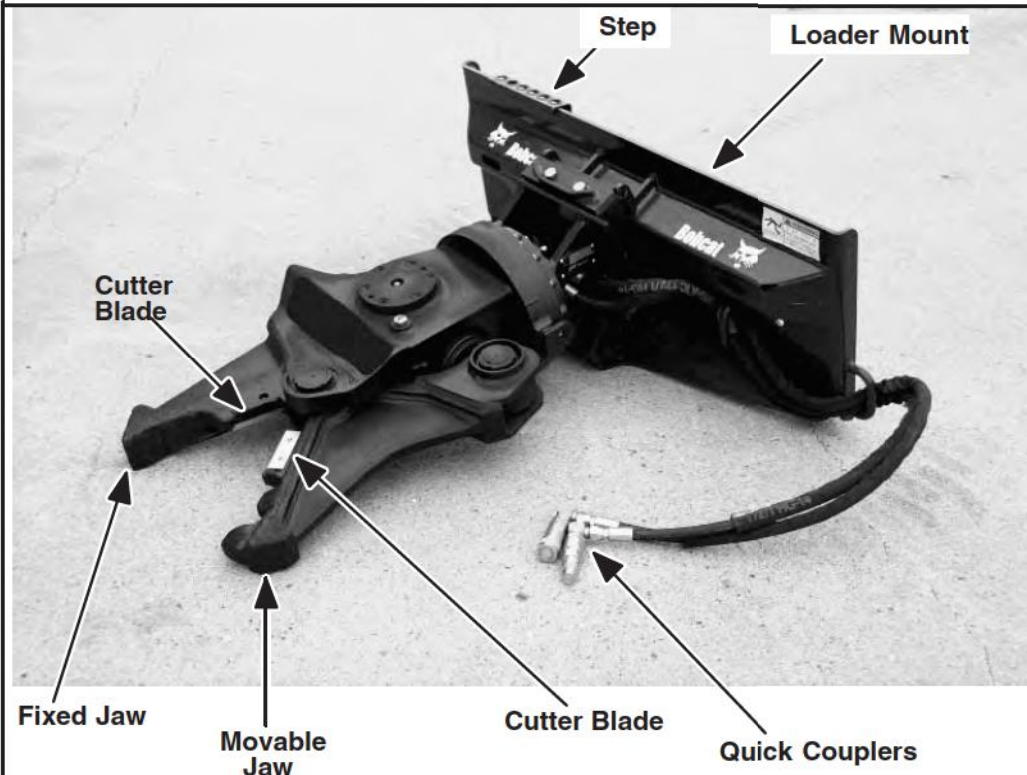

P-18242
P-18244

Dealer Copy -- Not for Resale

PARTS IDENTIFICATION (Cont'd)
Excavator Mount

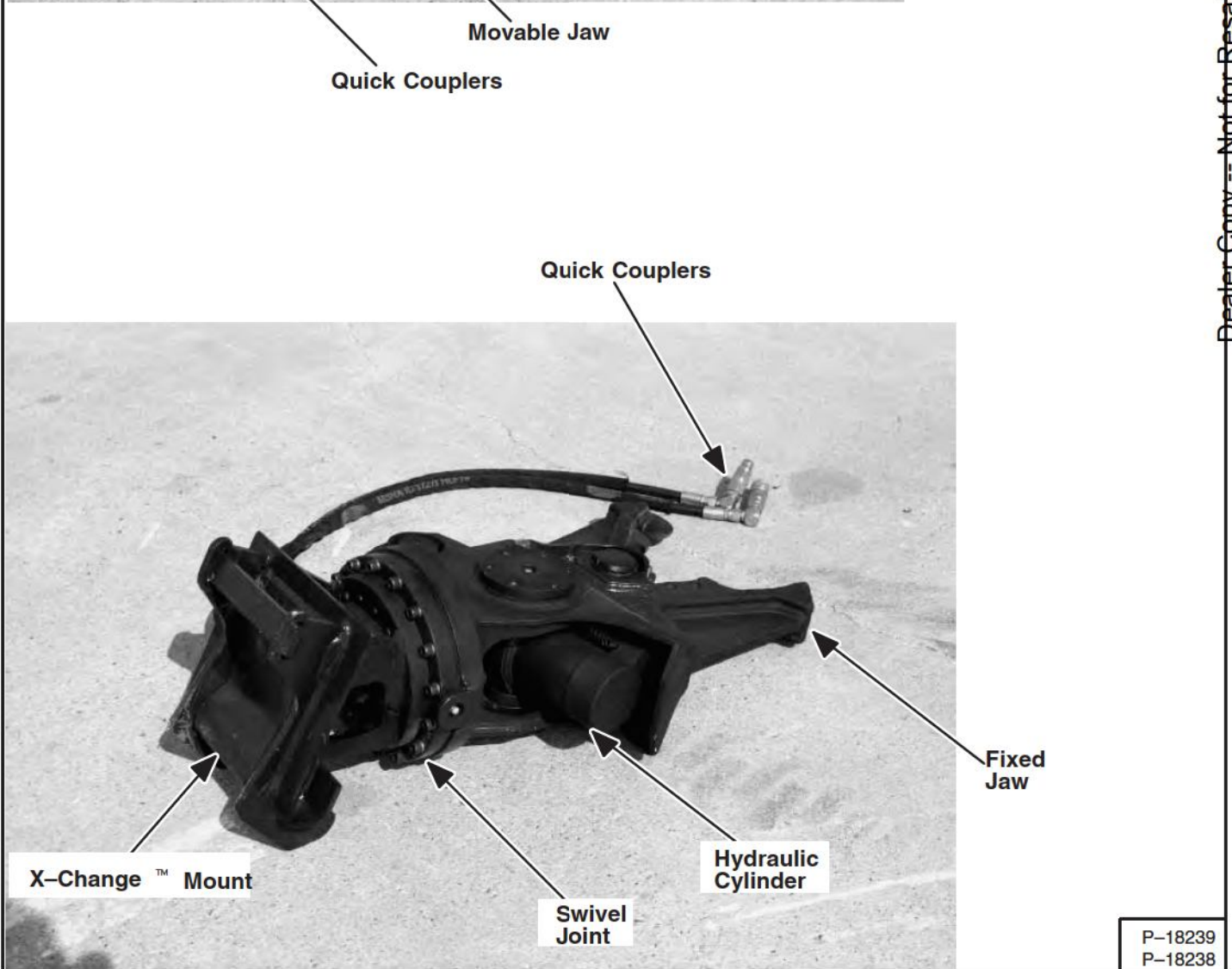
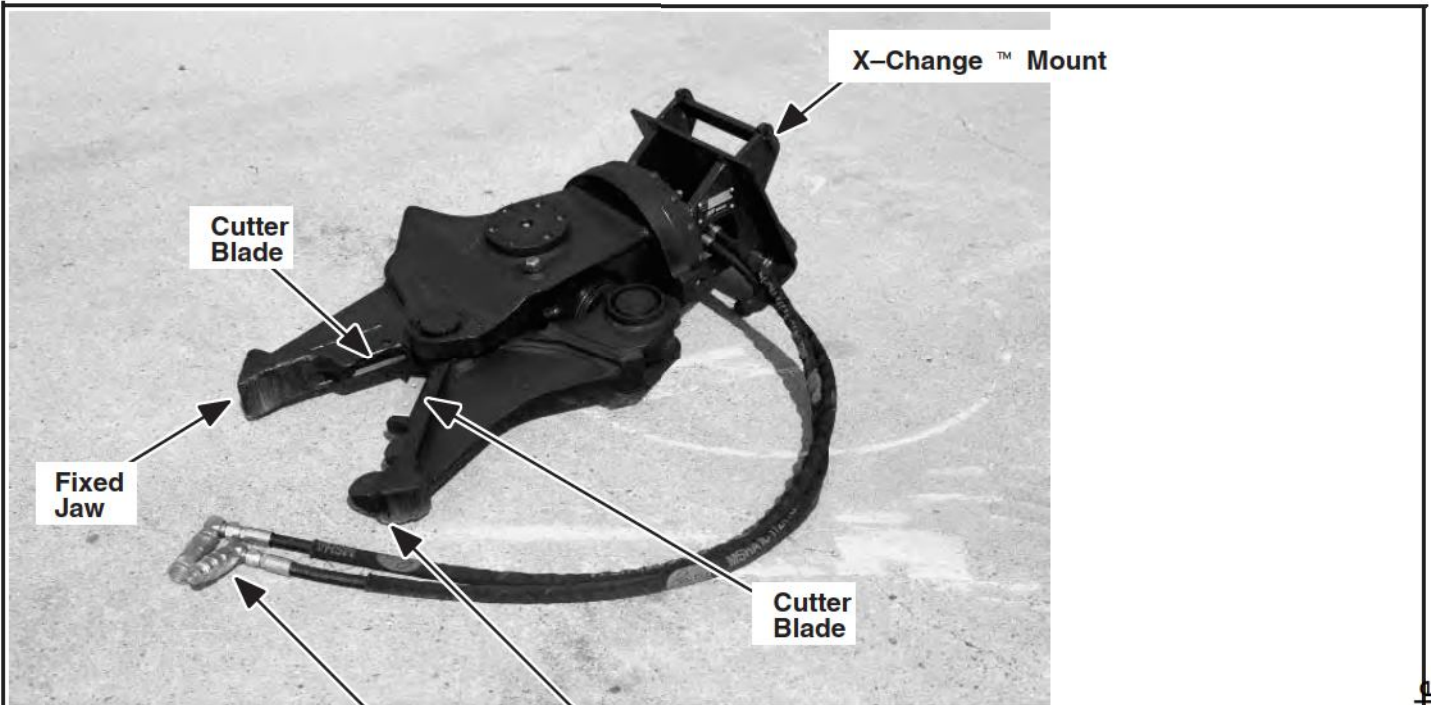

P-18239
P-18238

Dealer Copy --- Not for Resale

SAFETY AND MAINTENANCE

CRUSHER TEETH REPLACEMENT	10-10-8
CUTTING BLADES	
Removal And Installation	10-10-6
HARD SURFACING WEAR AREAS	10-10-8
INSPECTION	
Daily Inspection	10-10-4
Excavator Mount Inspection	10-10-4
Hand Lever BobTach Inspection	10-10-2
Loader Mount Inspection	10-10-4
Power BobTach Inspection	10-10-3
LUBRICATION	
Lubrication Points	10-10-5
TROUBLESHOOTING	10-10-1
WELDING TEMPLATE INFORMATION	
Model 30	10-10-9
Model 40	10-10-10

**SAFETY AND
MAINTENANCE**

Dealer Copy -- Not for Resale

TROUBLESHOOTING



Instructions are necessary before operating or servicing machine, Read Operation & Maintenance Manual, Handbook and signs (decals) on machine. Follow warnings and instructions in the manuals when making repairs, adjustments or servicing. Check for correct function after adjustments, repairs or service. Failure to follow instructions can cause injury or death.

W-2003-0199

If the Cutter Crusher is not working correctly, check the hydraulic system of the Bobcat loader or excavator thoroughly before making any repairs on the crusher. Cutter Crusher problems can be affected by a hydraulic system that is not operating to specifications or such problems as a plugged fuel filter or hydraulic filter in the loader or excavator. Connect a flow meter to the loader or excavator to check the hydraulic pump output, relief valve setting and tubelines to check flow and pressure. (See the loader Service Manual for the correct procedure to connect the flowmeter.)

PROBLEM	CAUSE	CORRECTION
Cutter Crusher does not crush.	Loader or excavator main relief valve set too low.	Adjust main relief valve to correct setting.
	Loader or excavator fluid reservoir is low	Add hydraulic fluid to the fluid reservoir in the loader or excavator.
	No hydraulic flow to the cutter crusher.	Check the hydraulic flow.
	Loader or excavator hydraulic pump not working..	Check flow of hydraulic pump. Repair or replace as needed.
	Worn crusher teeth.	Re-hard surface crusher jaw and teeth, replace teeth.
	Damaged quick couplers.	Replace quick couplers.
	Internal leakage of hydraulic cylinder.	Repair or replace hydraulic cylinder.
Cutter crusher does not cut.	Loader or excavator main relief valve set too low.	Adjust main relief valve to correct setting.
	Loader or excavator fluid reservoir is low	Add hydraulic fluid to the fluid reservoir in the loader or excavator.
	No hydraulic flow to the cutter crusher.	Check the hydraulic flow.
	Loader or excavator hydraulic pump not working.	Check flow of hydraulic pump. Repair or replace as needed.
	Worn cutting blades.	Rotate or replace blades.
	Incorrect blade clearance.	Check and adjust blade clearance.
	Internal leakage of hydraulic cylinder.	Repair or replace hydraulic cylinder.
Crusher jaw does not move.	Loader or excavator main relief valve set too low.	Adjust main relief valve to correct setting.
	Excessive back pressure.	Check for plugged or bent return lines.
	Crusher jaw blocked.	Remove debris from jaw.
	Damaged quick couplers.	Replace quick couplers.
	Internal leakage of hydraulic cylinder.	Repair or replace hydraulic cylinder.
	Hydraulic cylinder rod bent.	Repair or replace hydraulic cylinder.
	Loader or excavator fluid reservoir is low	Add hydraulic fluid to the fluid reservoir in the loader or excavator.
Excessive jaw movement.	Worn pins and bushings.	Replace pins and bushings.

Dealer Copy -- Not for Resale

INSPECTION

Hand Lever Bob-Tach Inspection

Move the Bob-Tach levers to engage the wedges [A]. The levers and wedges must move freely.

The wedges must extend through the holes in the attachment mounting frame (Item 1) [A].

WARNING

Bob-Tach wedges must extend through the holes in attachment. Lever(s) must be fully down and locked. Failure to secure wedges can allow attachment to come off and cause injury or death.

W-2102-0497

The spring loaded wedge (Item 1) [A] must contact the lower edge of the hole in the attachment (Item 1) [B] and [C].

If the wedge does not contact the lower edge of the hole [B] and [C], the attachment will be loose and can come off the Bob-Tach.

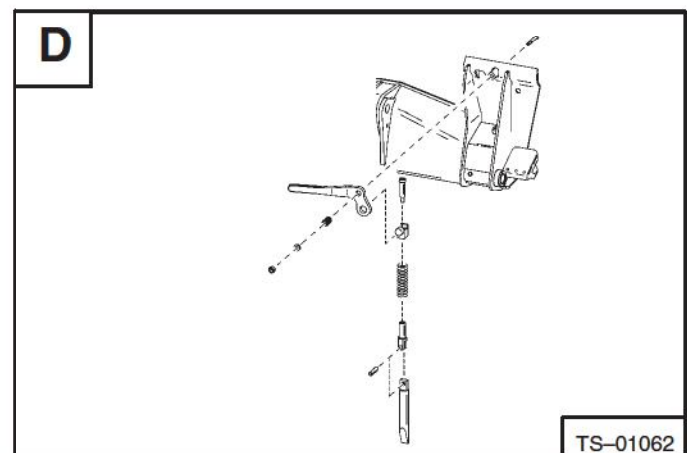
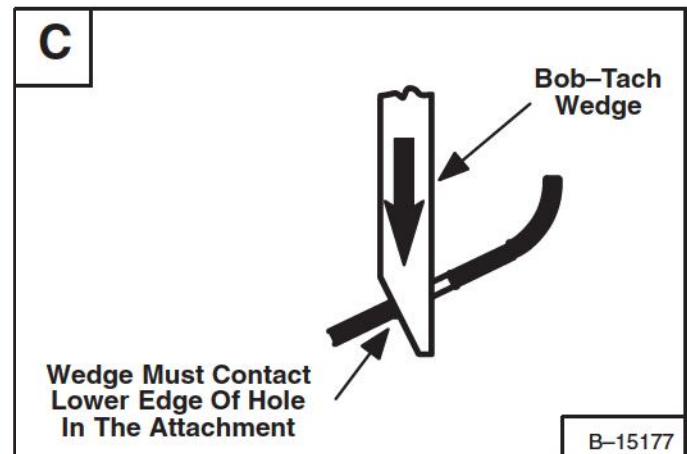
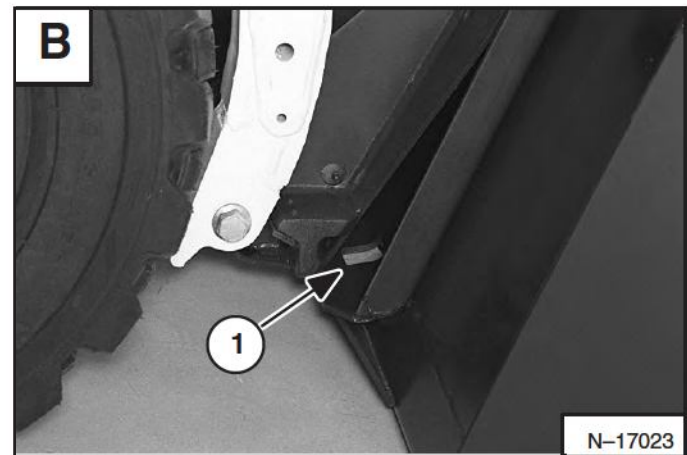
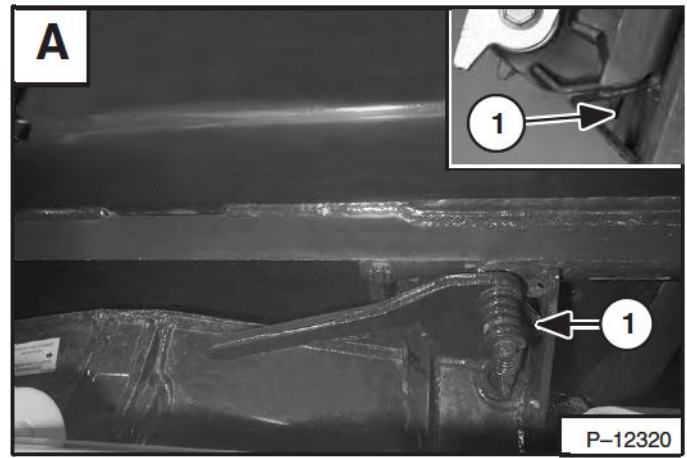

Inspect the mounting frame on the attachment and the Bob-Tach, linkages and wedges for excessive wear or damage [D]. Replace any parts that are damaged, bent, or missing. Keep all fasteners tight.

Look for cracked welds. Contact your Bobcat dealer for repair or replacement parts.

Lubricate the wedges (See the correct loader Service Manual for *LUBRICATION OF THE BOBCAT LOADER*).

INSPECTION(Cont'd)

Power Bob-Tach Inspection

Push and hold the Bob-Tach “WEDGES UP” switch [A] until wedges are fully raised. Push and hold the Bob-Tach “WEDGES DOWN” switch [A] until the wedges are fully down. The wedges must move freely.

The wedges must extend through the holes in the attachment mounting frame (Item 1) [B] and must contact the lower edge of the hole in the attachment [B] and (Item 1) [C].

If the wedge does not contact the lower edge of the hole [C], the attachment will be loose and can come off the Bob-Tach.

Inspect the mounting frame on the attachment and the Bob-Tach, linkages and wedges for excessive wear or damage [D]. Replace any parts including decals and levers that are damaged, bent or missing. Keep all fasteners tight. Inspect the hoses and fittings for leaks.

Look for cracked welds. Contact your Bobcat dealer for repair or replacement parts.

Lubricate the wedges. (See the correct loader Service Manual for *LUBRICATION OF THE BOBCAT LOADER.*)

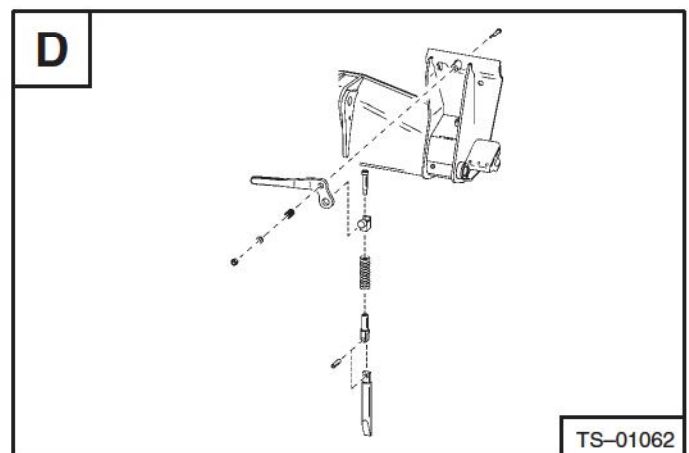
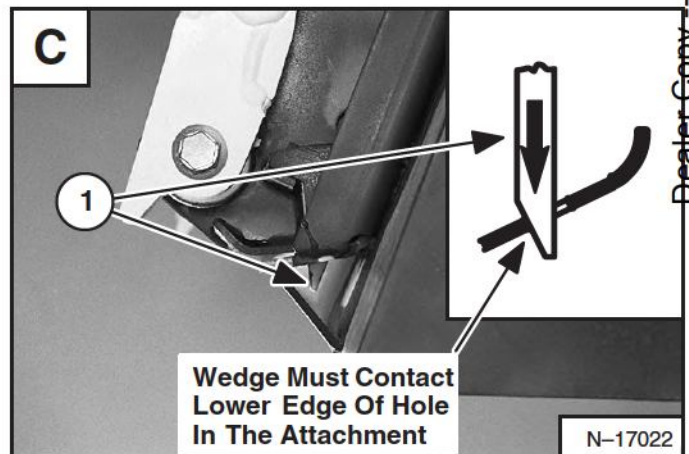
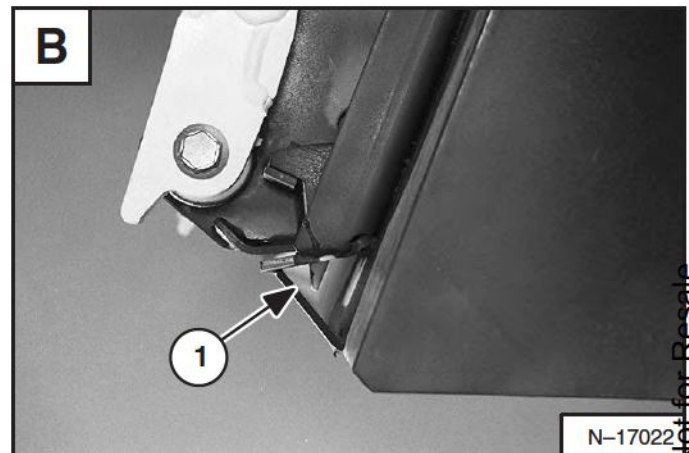
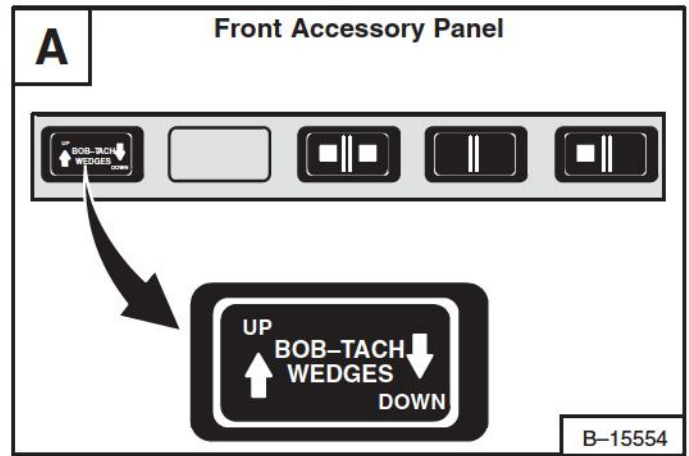

INSPECTION (Cont'd)

Loader Mount Inspection

Inspect the Bob-Tach wedge mounts (Item 1) [A], mounting flange (Item 2) [A], and all welds on the attachment mount for wear and damage each time the attachment is removed from the loader.

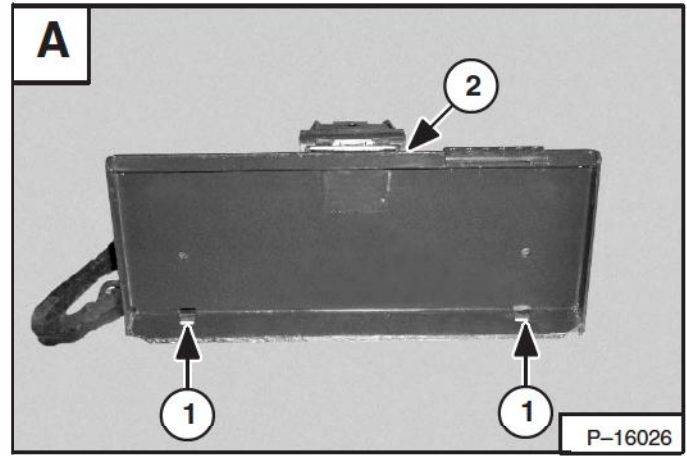

Excavator Mount Inspection

Inspect the X-Change™ mount (Item 1) [B] and all welds on the mount for wear and damage each time the attachment is removed from the excavator or from the loader mount.

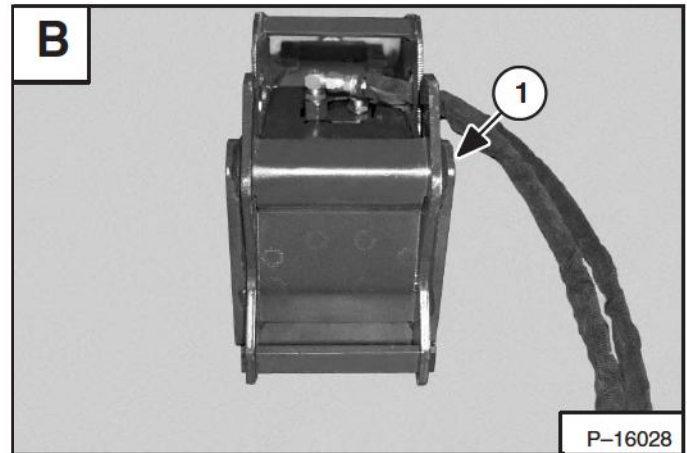

Daily Inspection

Inspect the cutting blades (Item 1) [C] for wear or damage. Rotate or replace the blades when the cutting edges have a radius of 0.15 inches (4 mm). (See page 10-10-6.)

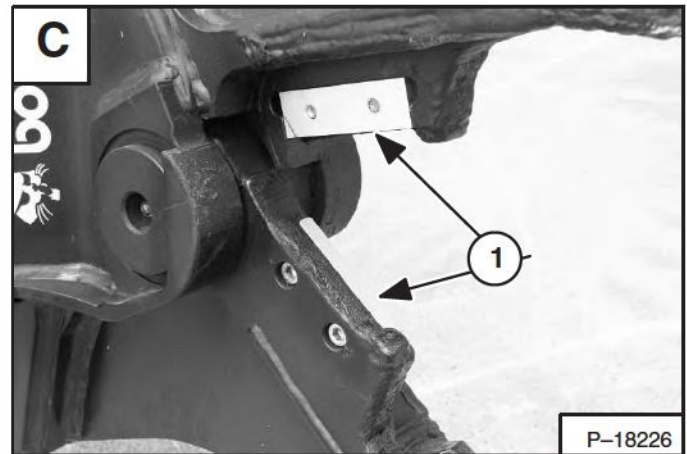

Inspect the crusher jaws and teeth (Item 1) [D] for wear or damage. Re-hard surface or replace the teeth as needed. (See page 46.)

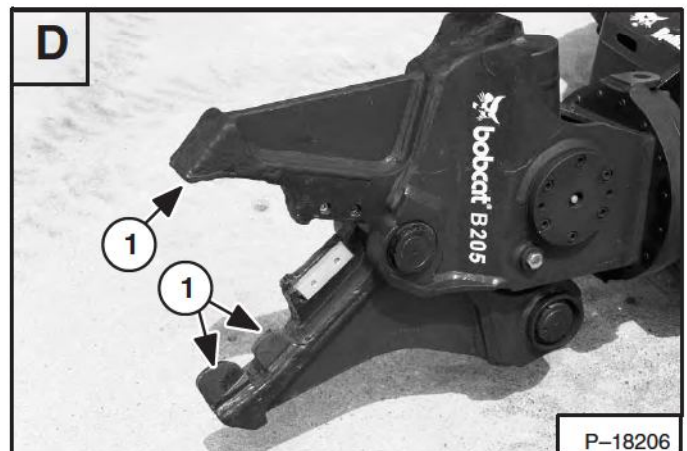

INSPECTION (Cont'd)

Daily Inspection (Cont'd)

Tighten the bolt on X-change™ plate bolts (Item 1) [A] to 125–140 ft.-lbs. (170–190 Nm) torque.

LUBRICATION

Lubrication Points

Always use a good quality lithium base grease when lubricating the cutter crusher. Apply the lubricant until extra grease shows.

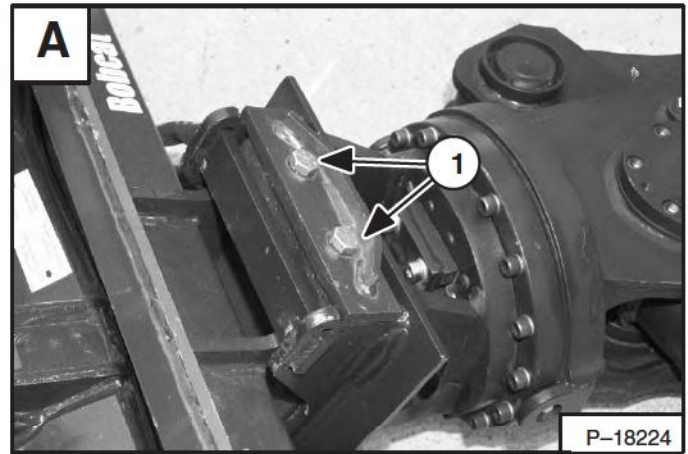

IMPORTANT

Fluid such as engine oil, hydraulic fluid, coolants, grease, etc. must be disposed of in an environmentally safe manner. Some regulations require that certain spills and leaks on the ground must be cleaned in a specific manner. See local, state and federal regulations for the correct disposal.

I-2067-0499

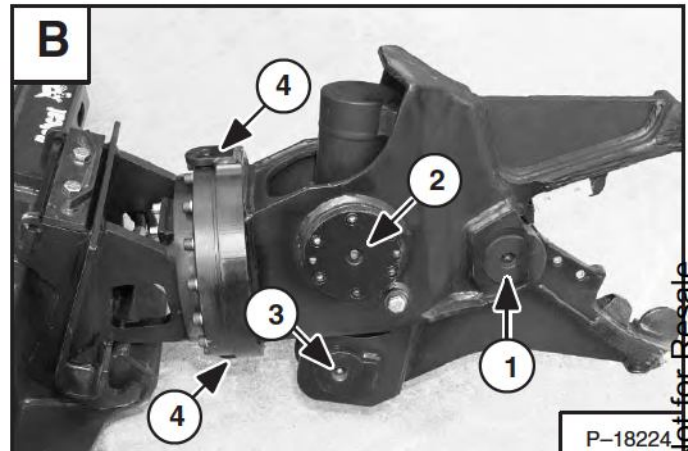

Lubricate the following grease fittings every **8–10 hours**.
Main shaft (Item 1) [B].

Trunnion (Item 2) [B] (both sides).

Cylinder rod end (Item 3) [B].

Swing bearing plate (Item 1) [C] (Model 30 only).

Rotate the slew gear while lubricating.

Lubricate the following grease fitting every **150 hours**:

Slew bearing (Item 4) [B] (both sides). Lubricate one fitting, rotate the cutter crusher and lubricate the second fitting.

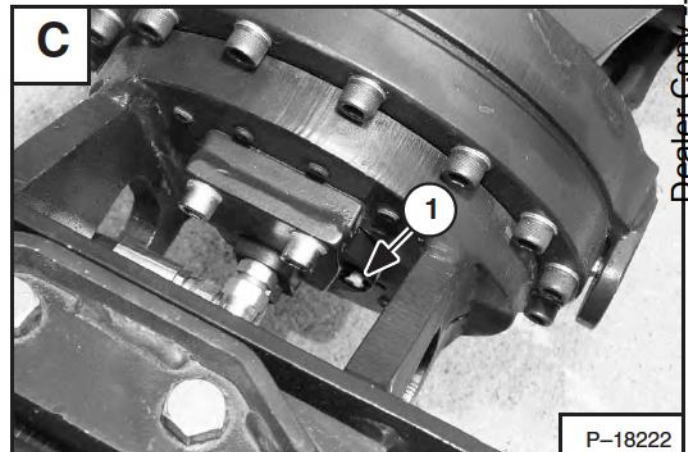

CUTTING BLADES

Removal And Installation

Fully open the crusher jaw.

Stop the loader/excavator and disconnect the auxiliary hoses before working on the cutter crusher.

When the cutting edge has a radius of 0.15 inches (4 mm) the blades should be removed, rotated and reinstalled using a new edge of the blade. When all four edges of the blade have a radius of 0.15 inches (4 mm) replace the blades.

NOTE: The procedure is shown on the model 30 cutter crusher. The model 40 cutter crusher has four bolts per blade. The procedure is the same for both cutter crushers.

Install a sling (Item 1) [A] on the crusher jaw supporting the cutter crusher.

Remove the bottom bolts (Item 1) [B].

Installation: Tighten the bolts to 36 ft.-lbs. (49 Nm) torque.

Remove the cutter blade (Item 1) [C].

Remove the shim (Item 1) [D].

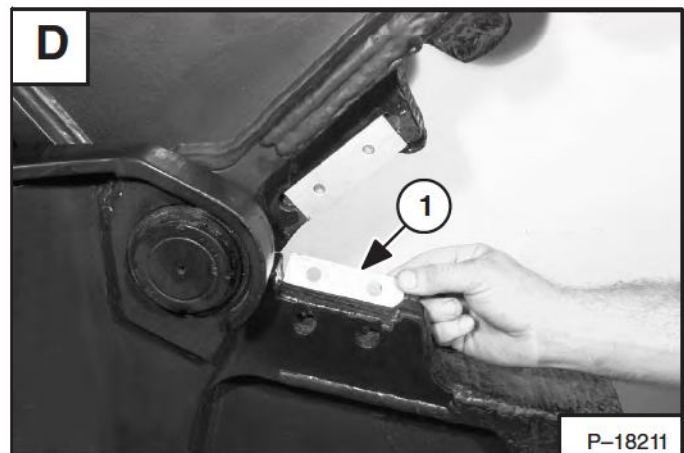
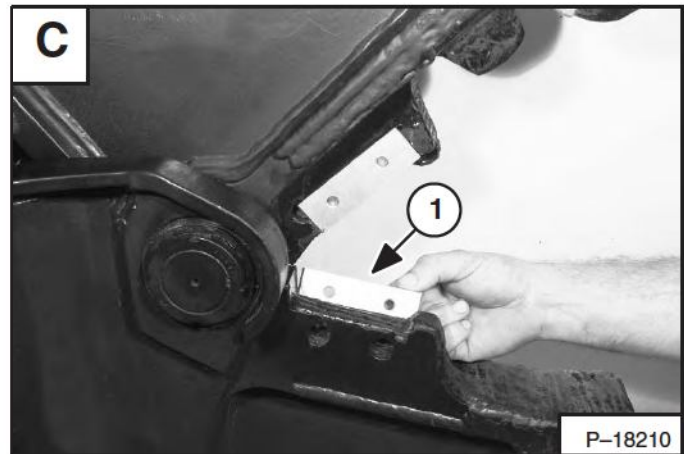
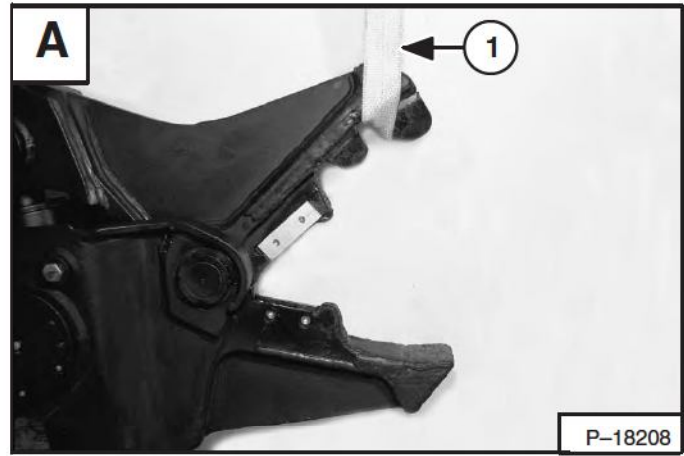

CUTTING BLADES (Cont'd)

Removal And Installation (Cont'd)

Remove the top bolts (Item 1) [A].

Installation: Tighten the bolts to 36 ft.-lbs. (49 Nm) torque.

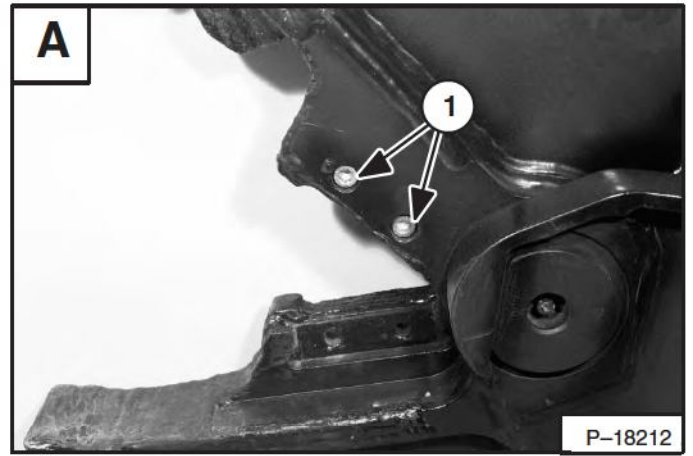

Remove the cutter blade (Item 1) [B].

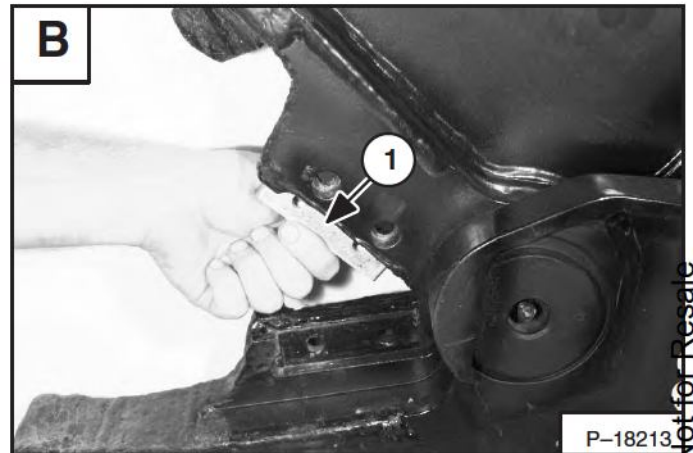

Remove the shim (Item 1) [C].

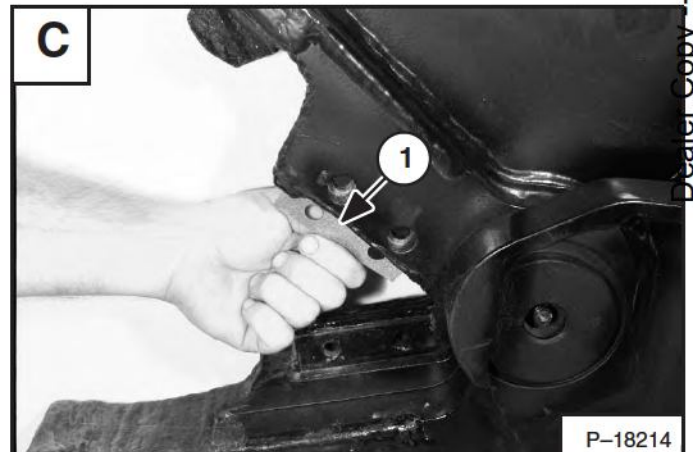

After rotating or installing new cutter blades, close the crusher jaw and measure the gap (Item 1) [D] between the blades.

Add or remove shims until a clearance of 0.019 – 0.039 inches (0.5 – 1.0 mm) is obtained.

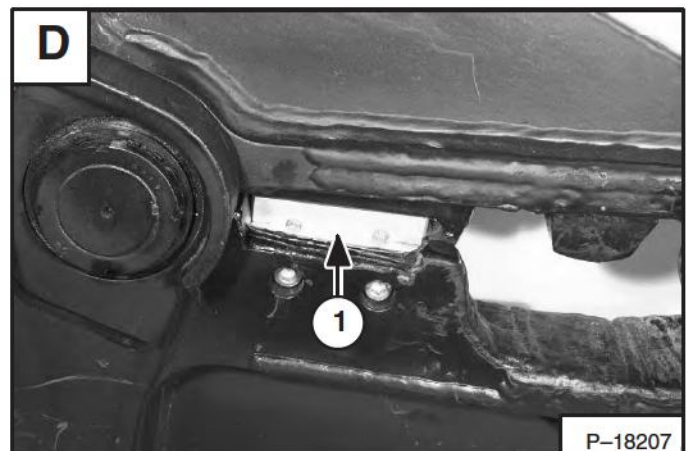

HARD SURFACING WEAR AREAS

Remove the cutter crusher from the loader/excavator when welding on the attachment.

Attach the ground cable close to the weld area on the same jaw being welded to prevent damage to the pivot bushings or hydraulic cylinder.

Apply hard surface welding to the top and sides (Item 1) [A] & [B] of both jaws, along both sides (Item 2) [A] & [B] of both jaws and on the top of the cutter blade mounts (Item 3) [A] & [B].

NOTE: When hard surface welding use MIG-wire DIN 8555: SG6-60 or welding rod DIN 8555: E6-55.

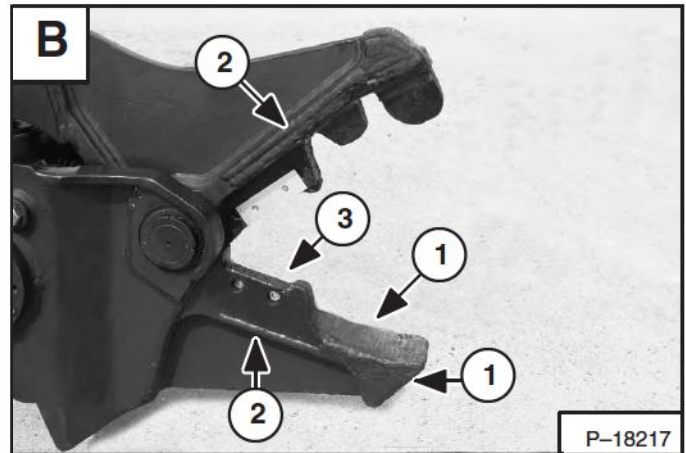
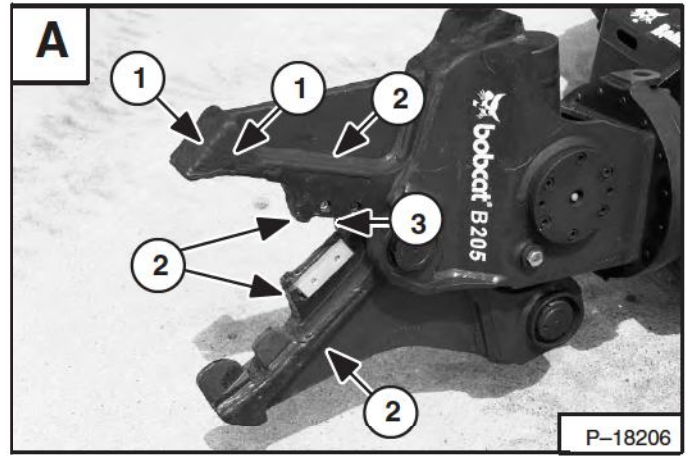

CRUSHER TEETH REPLACEMENT

Remove the worn or broken tooth.

Attach the ground cable close to the weld area on the same jaw being welded to prevent damage to the pivot bushings or hydraulic cylinder.

Tack weld the front and side tooth [C].

Close the crusher jaws to make sure the front tooth and side tooth does not interfere with the fixed jaw.

Preheat the jaw and tooth to 212 – 300° F (100 – 150° C) before welding.

NOTE: When repairing the crusher or installing a new tooth, use MIG wire DIN 8559: SG2 or welding rod DIN 1913:E51 53 B 10.

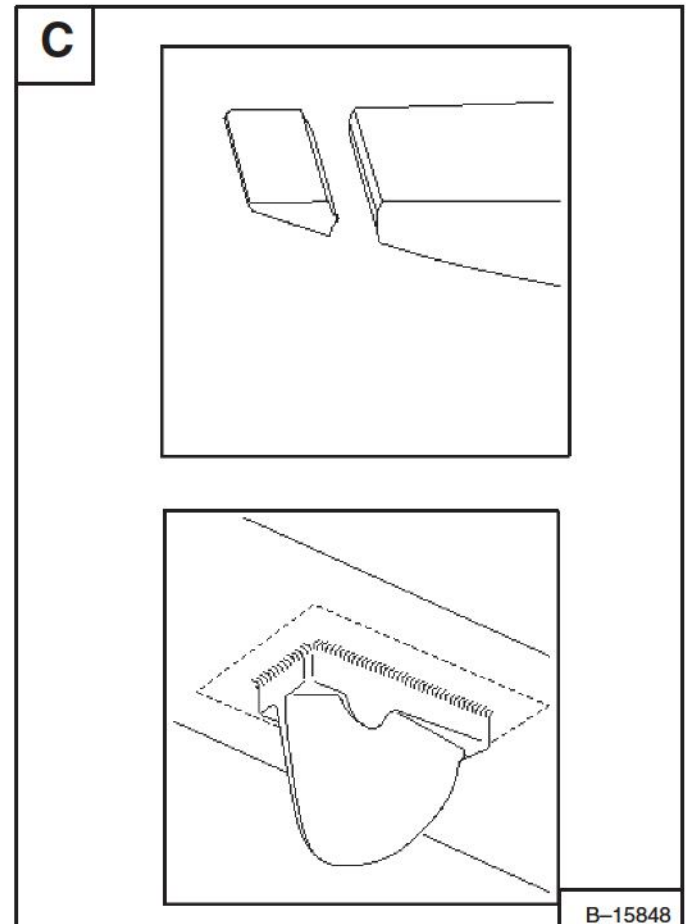

Dealer Copy -- Not for Resale



Suggest:

If the above button click is invalid.

Please download this document

first, and then click the above link

to download the complete manual.

Thank you so much for reading

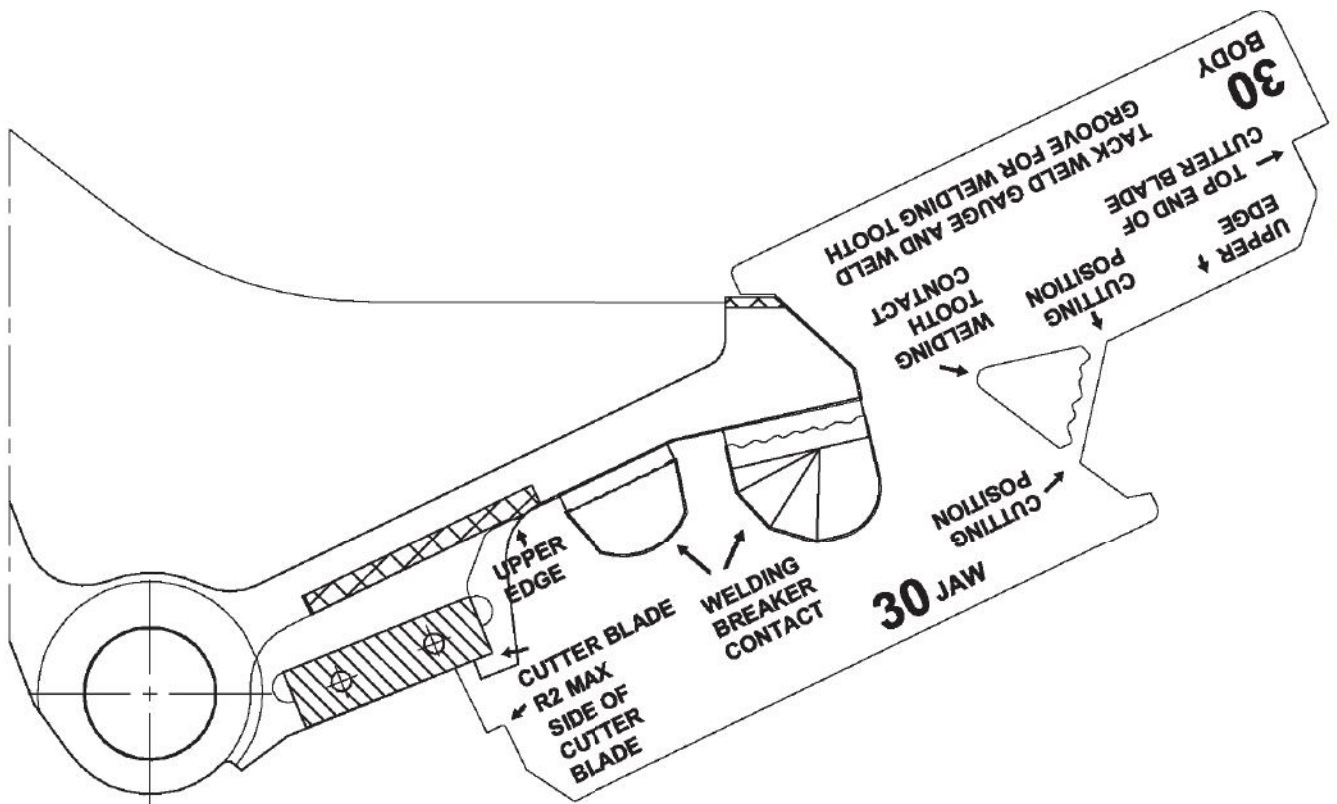
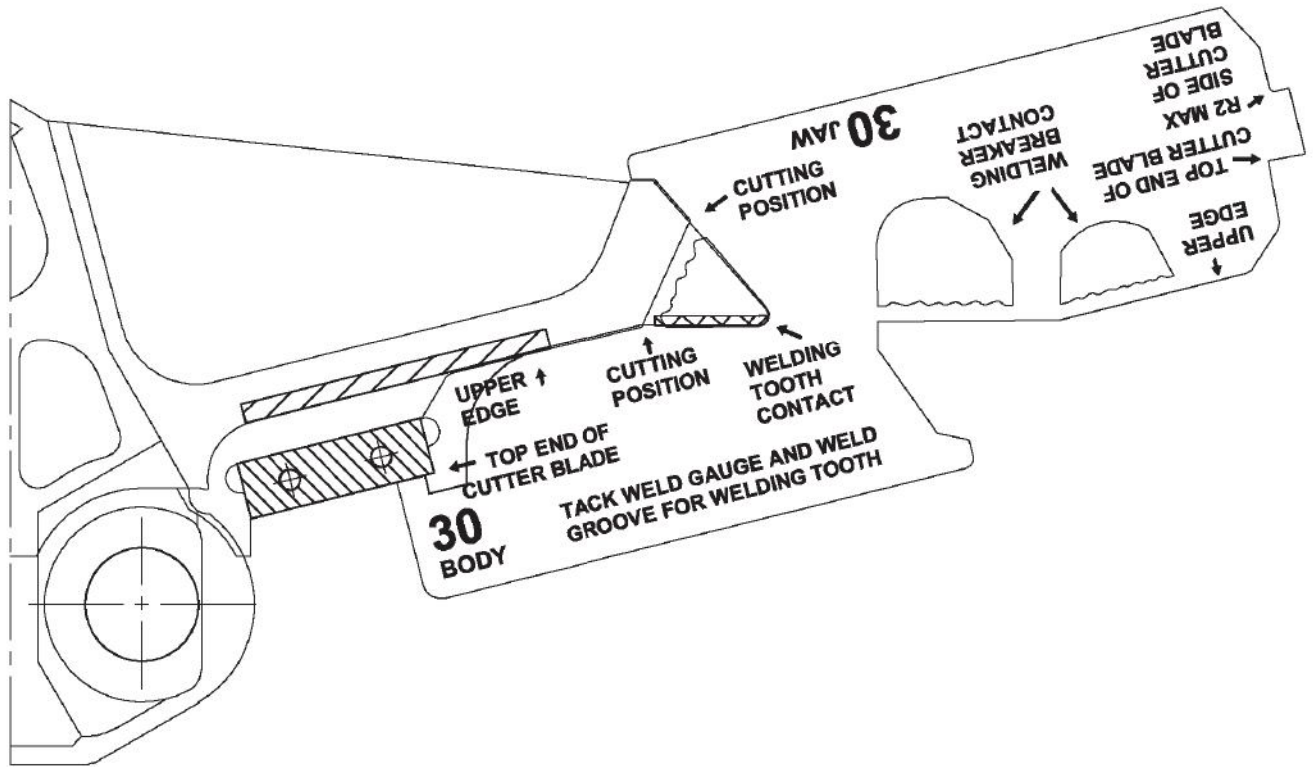

SEE THE WELDING TEMPLATE THAT IS INCLUDED IN THE OPERATION AND MAINTENANCE MANUAL IN THE SPECIFICATIONS SECTION.

MS-1079
MS-1080

<https://www.ebooklibonline.com>

Hello dear friend!

Thank you very much for reading.

Enter the link into your browser.

The full manual is available for immediate download.

<https://www.ebooklibonline.com>