

B250



Bobcat®

Service Manual

B Series

S/N 572911001 & Above

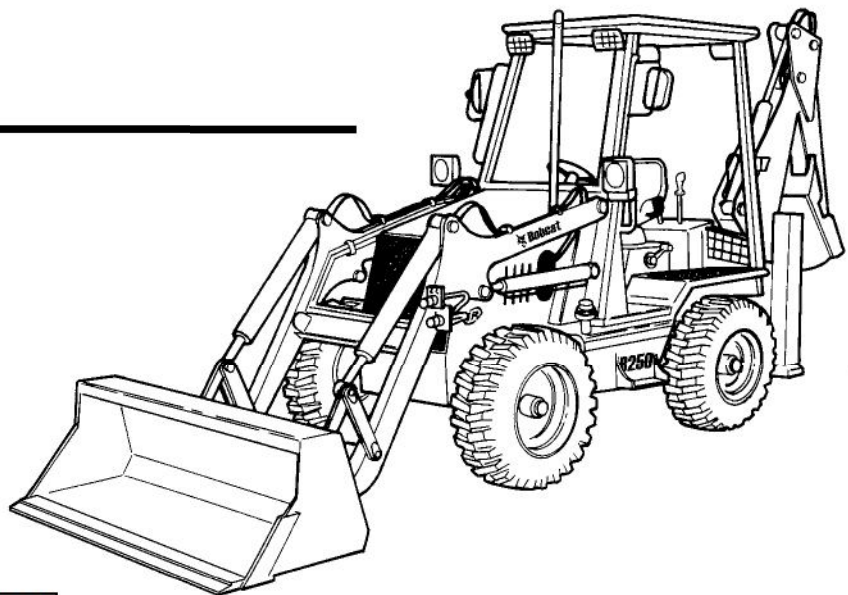

Doosan purchased Bobcat Company from Ingersoll-Rand Company in 2007. Any reference to Ingersoll-Rand Company or use of trademarks, service marks, logos, or other proprietary identifying marks belonging to Ingersoll-Rand Company in this manual is historical or nominative in nature, and is not meant to suggest a current affiliation between Ingersoll-Rand Company and Bobcat Company or the products of either.

MAINTENANCE SAFETY



WARNING

Instructions are necessary before operating or servicing machine. Read and understand the Operation & Maintenance Manual, Operator's Handbook and signs (decals) on machine. Follow warnings and instructions in the manuals when making repairs, adjustments or servicing. Check for correct function after adjustments, repairs or service. Untrained operators and failure to follow instructions can cause injury or death.

W-2003-0903



Safety Alert Symbol: This symbol with a warning statement, means: "Warning, be alert! Your safety is involved!" Carefully read the message that follows.

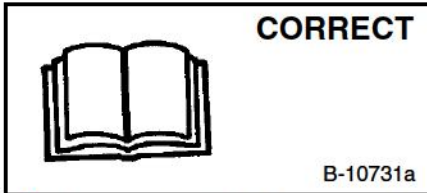

- Never service the Bobcat Loader Backhoe without instructions.

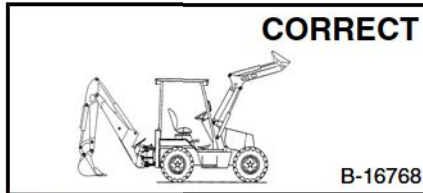

- Always use an approved lift arm support device when servicing the loader backhoe with the lift arms raised. Replace the lift arm support device if damaged or missing.
- Disconnecting or loosening any hydraulic tubeline, hose, fitting component, or part failure can cause lift arms or backhoe boom to drop.

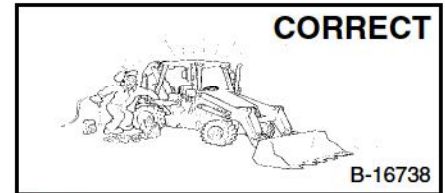

- Cleaning and maintenance are required daily.
- NEVER modify equipment or add attachments not approved by Bobcat.

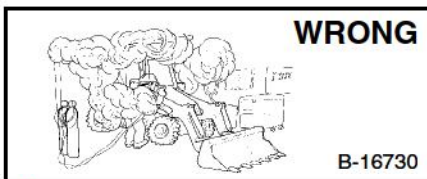

- Have good ventilation when welding or grinding painted parts.
- Wear dust mask when grinding painted parts. Toxic dust and gas can be produced.

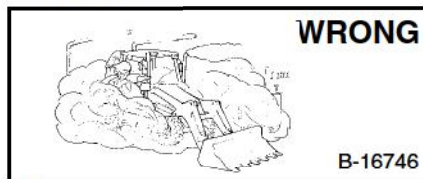

- Vent exhaust to outside when engine must be run for service.
- Exhaust system must be tightly sealed. Exhaust Fumes can kill without warning.



- Never work on loader backhoe with lift arms raised unless supported by an approved lift arm support device.
- Always lower the backhoe bucket to the ground before doing any maintenance.

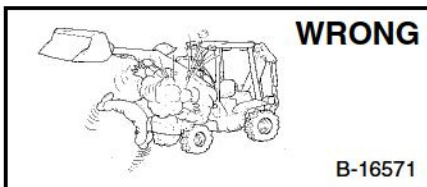

- Stop, cool and clean engine of flammable materials before checking fluids.
- Never service or adjust machine with the engine running unless instructed to do so in the manual.
- Avoid contact with leaking hydraulic fluid or diesel fuel under pressure. It can penetrate the skin or eyes.
- Never fill fuel tank with engine running, while smoking or when near open flame.



- Keep body, jewelry and clothing away from moving parts, electrical contact, hot parts and exhaust.
- Wear eye protection to guard from battery acid, compressed springs, fluids under pressure and flying debris when engines are running or tools are used.
- Use eye protection approved for type of welding.
- Keep engine cover closed except for service. Close and latch engine cover before operating the loader backhoe.



- Lead-acid batteries produce flammable and explosive gases.
- Keep arcs, sparks, flames and lighted tobacco away from batteries.
- Batteries contain acid which burns eyes or skin on contact. Wear protective clothing. If acid contacts body, flush well with water. For eye contact flush well and get immediate medical attention.

Maintenance procedures which are given in the Operation & Maintenance Manual can be performed by the owner/operator without any specific technical training. Maintenance procedures which are not in the Operation & Maintenance Manual must be performed **ONLY BY QUALIFIED BOBCAT SERVICE PERSONNEL**. Always use genuine Bobcat replacement parts.

MSW16-0805

Dealer Copy -- Not for Resale

ALPHABETICAL INDEX

| | | | |
|--|--------------|--------------------------------------|--------------|
| AIR CLEANER | 70-01 | HEATER FAN | 80-01 |
| AIR CLEANER SERVICE | 10-01 | HEATER UNIT | 80-01 |
| ALTERNATOR | 60-01 | HYDRAULIC FILTER HOUSING | 20-01 |
| ALTERNATOR BELT | 10-01 | HYDRAULIC FLUID RESERVOIR | 20-01 |
| APPROVED LIFT ARM SUPPORT DEVICE | 10-01 | HYDRAULIC SYSTEM INFORMATION | 20-01 |
| ARM CYLINDER | 20-01 | HYDRAULIC/HYDROSTATIC FLUID | |
| ARM | 50-01 | SPECIFICATIONS | SPEC-01 |
| AUXILIARY CONTROL VALVE | 20-01 | HYDRAULIC/HYDROSTATIC SYSTEM | 10-01 |
| AXLE AND DIFFERENTIAL (FRONT) | 40-01 | HYDROSTATIC DRIVE MOTOR | 30-01 |
| AXLE AND DIFFERENTIAL (REAR) | 40-01 | HYDROSTATIC PUMP | 30-01 |
| AXLE TOE-IN | 10-01 | HYDROSTATIC SYSTEM INFORMATION | 30-01 |
| | | HYDROSTATIC PUMP TESTING AND | |
| | | ADJUSTMENT | 30-01 |
| BACKHOE CONTROL VALVE | 20-01 | | |
| BATTERY | 60-01 | INSTRUMENT PANEL | 60-01 |
| BOB-TACH | 10-01, 50-01 | | |
| BOOM | 50-01 | LIFT ARMS | 50-01 |
| BOOM CYLINDER | 20-01 | LIFT CYLINDER | 20-01 |
| BOOM LOCK PIN | 10-01 | LIFTING AND BLOCKING THE | |
| BRAKE CALIPER | 40-01 | LOADER BACKHOE | 10-01 |
| BUCKET | 50-01 | LOADER BACKHOE SPECIFICATIONS | SPEC-01 |
| BUCKET CYLINDER | 20-01 | LOADER BACKHOE TORQUE | SPEC-01 |
| | | LOADER CONTROL VALVE | 20-01 |
| CAB DOOR | 50-01 | LUBRICATING THE LOADER BACKHOE | 10-01 |
| CAB LIGHTS | 60-01 | | |
| COMPONENTS | 80-01 | MAIN RELIEF VALVE | 20-01 |
| CONVERSIONS | SPEC-01 | MUFFLER | 70-01 |
| | | | |
| DRIVESHAFT | 40-01 | OIL COOLER | 30-01 |
| DROP BOX | 40-01 | OPERATOR CAB | 50-01 |
| | | OPERATOR SEAT | 50-01 |
| ELECTRICAL SYSTEM INFORMATION | 60-01 | | |
| ENCLOSED CAB | 50-01 | PARKING BRAKE | 40-01 |
| ENGINE | 70-01 | PORT RELIEF VALVE | |
| ENGINE COMPONENTS AND TESTING | 70-01 | (BACKHOE CONTROL VALVE) | 20-01 |
| ENGINE COOLING SYSTEM | 10-01 | PORT RELIEF VALVE | |
| ENGINE COVER | 10-01, 50-01 | (LOADER CONTROL VALVE) | 20-01 |
| ENGINE LUBRICATION SYSTEM | 10-01 | | |
| ENGINE SIDE COVERS | 50-01 | RADIATOR | 70-01 |
| ENGINE SPECIFICATIONS | SPEC-01 | REAR AXLE | 10-01, 40-01 |
| ENGINE SPEED CONTROL | 70-01 | REAR WINDOW | 50-01 |
| | | REAR WIPER | 60-01 |
| FENDER | 50-01 | RECONDITIONING THE ENGINE | 70-01 |
| FLOOR PANELS | 50-01 | RUBBER DRIVE COUPLER | 70-01 |
| FLYWHEEL | 70-01 | | |
| FLYWHEEL HOUSING | 70-01 | SAPR BRAKE CONTROL VALVE | 20-01 |
| FRONT AXLE | 10-01, 40-01 | SAPR BRAKE CYLINDER | 20-01 |
| FRONT AXLE PIVOT FRAME | 50-01 | SERVICE SCHEDULE | 10-01 |
| FRONT LIGHTS | 60-01 | SIDE SHIFT LOCK CYLINDER | 20-01 |
| FRONT WIPER | 60-01 | STABILIZER FRAME | 50-01 |
| FUEL LEVEL SENDER | 60-01 | STABILIZER CYLINDER | 20-01 |
| FUEL SYSTEM | 10-01 | STEERING ANGLE ADJUSTMENT | |
| FUEL TANK | 50-01 | (FRONT AXLE) | 40-01 |
| | | STEERING ANGLE ADJUSTMENT | |
| GEAR PUMP | 20-01 | (REAR AXLE) | 40-01 |
| GRILL | 50-01 | | |
| GRILL FRAME | 50-01 | | |

ALPHABETICAL INDEX (CONT'D)

| | |
|---------------------------------------|--------------|
| STEERING CYLINDER (FRONT) | 20-01 |
| STEERING CYLINDER (REAR) | 20-01 |
| STEERING PUMP | 20-01 |
| STEERING VALVE | 20-01 |
| STARTER | 60-01 |
| SWING CYLINDER | 20-01 |
| SWING FRAME | 50-01 |
| SWING LOCK PIN | 10-01 |
| | |
| TILT CYLINDER | 20-01 |
| TIRE MAINTENANCE | 10-01 |
| TORQUE SPECIFICATIONS | |
| FOR BOLTS | SPEC-01 |
| TOWING THE LOADER BACKHOE | 10-01 |
| TRANSPORTING THE LOADER BACKHOE | 10-01 |
| TRAVEL PEDAL | 20-01 |
| TROUBLESHOOTING | 40-01, 70-01 |
| TURBOCHARGER | 70-01 |
| TURN INDICATOR LIGHTS (FRONT) | 60-01 |
| TURN INDICATOR LIGHTS (REAR) | 60-01 |
| | |
| X-CHANGE™ | 50-01 |

<https://www.ebooklibonline.com>

Hello dear friend!

Thank you very much for reading.

Enter the link into your browser.

The full manual is available for immediate download.

<https://www.ebooklibonline.com>

CONTENTS

| | |
|--------------------------------------|---------|
| FOREWORD..... | II |
| SAFETY INSTRUCTIONS | V |
| SERIAL NUMBER LOCATION | IX |
| DELIVERY REPORT..... | X |
| BOBCAT LOADER IDENTIFICATION..... | XI |
| SAFETY & MAINTENANCE | 10-01 |
| HYDRAULIC SYSTEM | 20-01 |
| HYDROSTATIC SYSTEM..... | 30-01 |
| DRIVE SYSTEM | 40-01 |
| MAIN FRAME | 50-01 |
| ELECTRICAL SYSTEM AND ANALYSIS | 60-01 |
| ENGINE SERVICE | 70-01 |
| HEATER | 80-01 |
| SPECIFICATIONS..... | SPEC-01 |

**SAFETY &
MAINTENANCE**

**HYDRAULIC
SYSTEM**

**HYDROSTATIC
SYSTEM**

**DRIVE
SYSTEM**

MAIN FRAME

**ELECTRICAL
SYSTEM &
ANALYSIS**

**ENGINE
SERVICE**

HEATER

SPECIFICATIONS

FOREWORD

This manual is for the Bobcat loader mechanic. It provides necessary servicing and adjustment procedures for the Bobcat loader and its component parts and systems. Refer to the Operation & Maintenance Manual for operating instructions, Starting procedure, daily checks, etc.

A general inspection of the following items must be made after the loader has had service or repair:

1. Check that ROPS mounting hardware is tightened and is Bobcat approved.



2. The seat belt must be correctly installed, functional and in good condition.

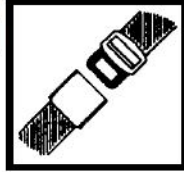

3. Check lift arm support device, replace if damaged.

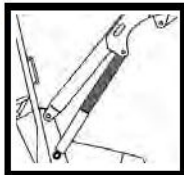

4. Machine signs must be legible and in the correct location.



5. Foot pedal must return to neutral.

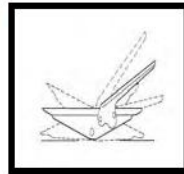

6. Check for correct function of the work lights



7. The parking brake must function correctly.



8. Enclosure door latches must open and close freely.



9. Bob-Tach wedges and linkages must function correctly and be in good condition.



10. Safety treads must be in good condition.



11. Check for correct function of indicator lamps (Optional on some models).

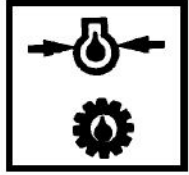

12. Check hydraulic fluid level, engine oil level and fuel supply.



13. Inspect for fuel, oil or hydraulic fluid leaks.



14. Lubricate the loader backhoe.



15. Check the condition of the battery and cables.

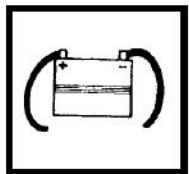

16. Inspect the air cleaner for damage or leaks. Check the condition of the element.

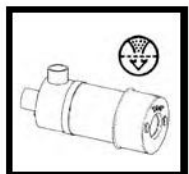

Dealer Copy -- Not for Resale

17. Check the electrical charging system.

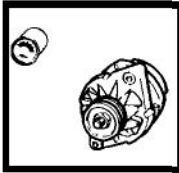

20. Operate the loader and check all functions.



18. Check tires for wear and pressure.

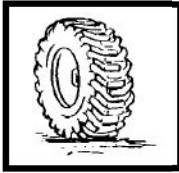

21. Check for any field modification not completed.



19. Inspect for loosen or broken parts or connections.



22. Recommend to the owner that all necessary corrections be made before the machine is returned to service.



**CALIFORNIA
PROPOSITION 65 WARNING**
Diesel engine exhaust and some of its constituents are known to the State of California to cause cancer, birth defects and other reproductive harm.

SAFETY INSTRUCTIONS



Safety Alert Symbol

This symbol with a warning statement means: **“Warning, be alert! Your safety is involved!”**
Carefully read the message that follows.



WARNING

Instructions are necessary before operating or servicing machine. Read and understand the Operation & Maintenance Manual, Operator's Handbook and signs (decals) on machine. Follow warnings and instructions in the manuals when making repairs, adjustments or servicing. Check for correct function after adjustments, repairs or service. Untrained operators and failure to follow instructions can cause injury or death.

W-2003-0903



WARNING

Warnings on the machine and in the manuals are for your safety. Failure to obey warnings can cause injury or death.

W-2044-1285

IMPORTANT

This notice identifies procedures which must be followed to avoid damage to the machine.

I-2019-0284

The following publications provide information on the safe use and maintenance of the Bobcat machine and attachments:

- The Delivery Report is used to assure that complete instructions have been given to the new owner and that the machine is in safe operating condition.
- The Operation & Maintenance Manual delivered with the machine or attachment contains operating information as well as routine maintenance and service procedures. It is a part of the machine and can be stored in a container provided on the machine. Replacement Operation & Maintenance Manuals can be ordered from your Bobcat dealer.
- Machine signs (decals) instruct on the safe operation and care of your Bobcat machine or attachment. The signs and their locations are shown in the Operation & Maintenance Manual. Replacement signs are available from your Bobcat dealer.
- An Operator's Handbook fastened to the operator cab. It's brief instructions are convenient to the operator. The handbook is available from your dealer in an English edition or one of many other languages. See your Bobcat dealer for more information on translated versions.
- The AEM Safety Manual delivered with the machine gives general safety information.
- The Service Manual and Parts Manual are available from your dealer for use by mechanics to do shop-type service and repair work.
- The Loader Backhoe Operator Training Course is available through your local dealer or at www.training.bobcat.com or www.bobcat.com. This course is intended to provide rules and practices of correct operation of the Loader Backhoe.
- The Loader Backhoe Safety Video is available from your Bobcat dealer or at www.training.bobcat.com or www.bobcat.com.

Dealer Copy -- Not for Resale

SI LB-0206 SM

SAFETY INSTRUCTIONS (CONT'D)

Fire Prevention

The machine and attachments have components that are at high temperature under normal operating conditions. The primary source of high temperatures is the engine and exhaust system. The electrical system, if damaged or incorrectly maintained, can be a source of arcs or sparks.

Flammable debris (leaves, straw, etc.) must be removed regularly. If flammable debris is allowed to accumulate, it will increase fire hazard. Clean often to avoid this accumulation. Flammable debris in the engine compartment is a potential hazard.

The spark arrestor muffler is designed to control the emission of hot particles from the engine and exhaust system, but the muffler and the exhaust gases are still hot.

- Do not use the machine where exhaust, arcs, sparks or hot components can contact flammable material, explosive dust or gases.
- The operator cab, engine compartment, and engine cooling system must be inspected every day and cleaned if necessary to prevent fire hazard and overheating.
- Check all electrical wiring and connections for damage. Keep the battery terminals clean and tight. Repair or replace any damaged part.
- Check fuel and hydraulic tubes, hoses and fittings for damage and leakage. Never use open flame or bare skin to check for leaks. Tighten or replace any parts that show leakage. Always clean fluid spills. Do not use gasoline or diesel fuel for cleaning parts. Use commercial nonflammable solvents.
- Do not use ether or starting fluids on any engine which has glow plugs. These starting aids can cause explosion and injure you or bystanders.
- Always clean the machine, disconnect the battery, and disconnect the wiring from the controllers before welding. Cover rubber hoses, battery and all other flammable parts. Keep a fire extinguisher near the machine when welding. Have good ventilation when grinding or welding painted parts. Wear a dust mask when grinding painted parts. Toxic dust or gas can be produced.
- Stop the engine and let it cool before adding fuel. **NO SMOKING!**

- Use the procedure in the Operation & Maintenance Manual for connecting the battery and for jump starting.
- Use the procedure in the Operation & Maintenance Manual for cleaning the spark arrestor muffler (if equipped).

Figure 1

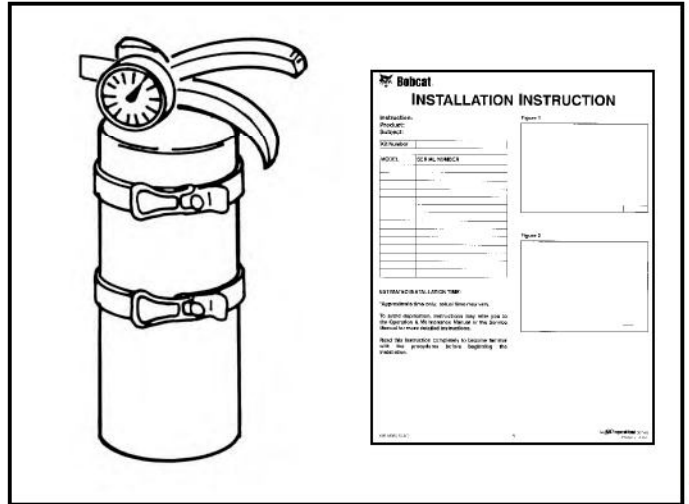

- Know where fire extinguishers and first aid kits are located and how to use them. Fire extinguishers are available from your Bobcat dealer [Figure 1].

Dealer Copy -- Not for Resale

SERIAL NUMBER LOCATION

Always use the serial number of the loader backhoe when requesting service information or when ordering parts. Early or later models (identification made by serial number) may use different parts, or it may be necessary to use a different procedure in doing a specific service operation.

Loader Backhoe Serial Number

Figure 1

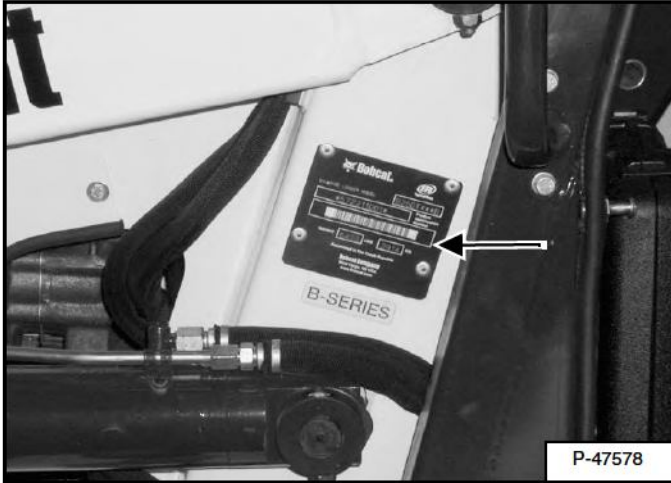

The loader backhoe serial number plate is located under the loader lift arm on the left side [Figure 1].

Explanation of loader Serial Number:

| XXXX | XXXXX |
|------------------------------------|---------------------------------------|
| Model 1.-Model/ Engine Combination | Model 2.-Production Sequence (Series) |

1. The four digit Model/Engine Combination Module number identifies the model number and engine combination.
2. The five digit Production Sequence Number identifies the order which the loader is produced.

Engine Serial Number

Figure 2

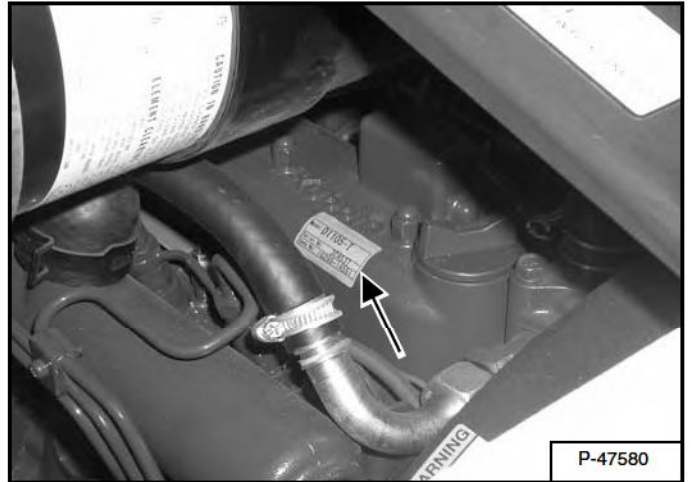

The engine serial number is located on the valve cover at the right side of the engine [Figure 2].

DELIVERY REPORT

Figure 3

The diagram shows a form titled "DELIVERY REPORT" with a "WARNING" section and a reference code "B-16315".

The Delivery Report must be filled out by the dealer and signed by the owner or operator when the Bobcat loader backhoe is delivered. An explanation of the form must be given to the owner. Make sure it is filled out completely [Figure 3].

BOBCAT LOADER IDENTIFICATION

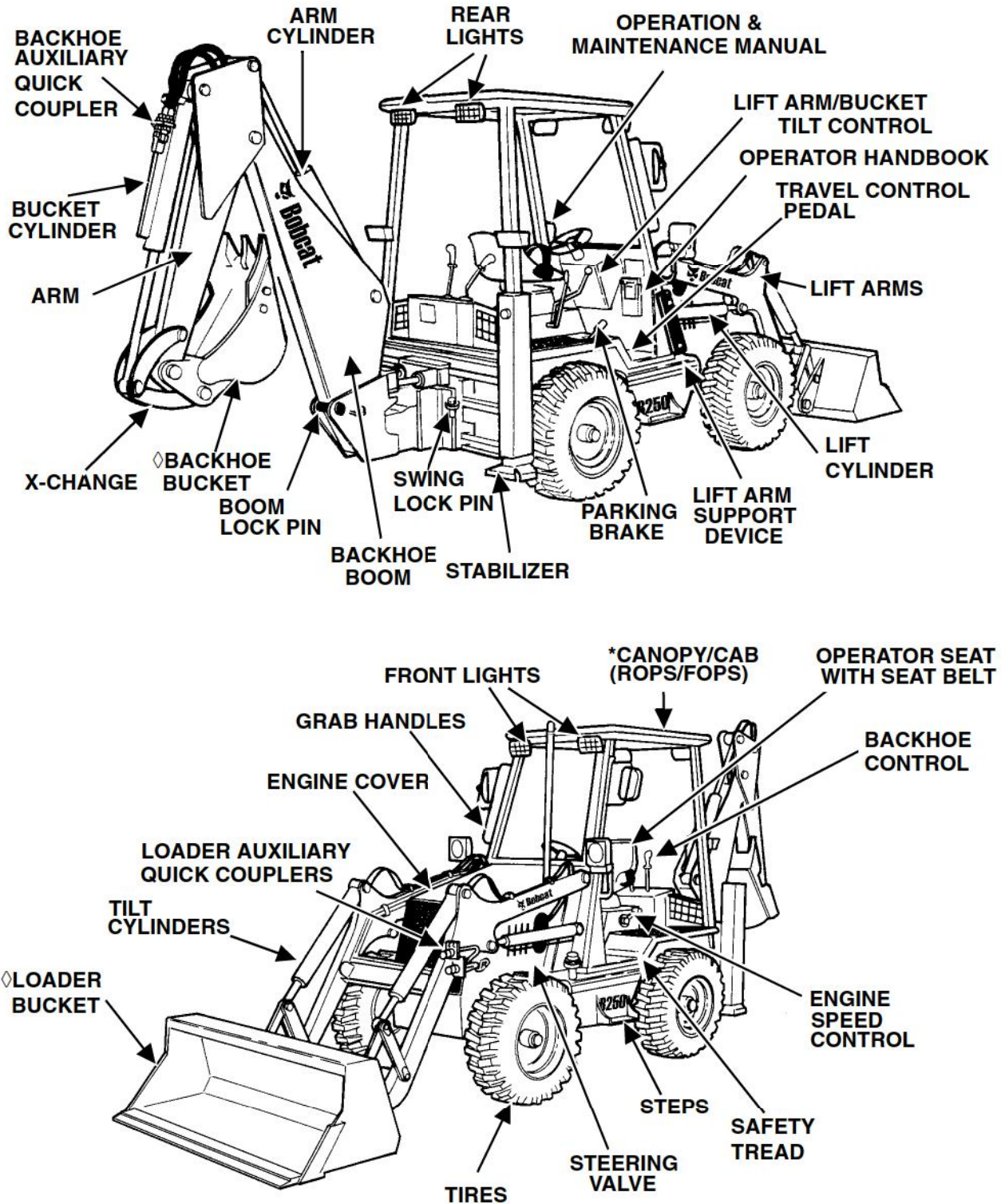

Dealer Copy -- Not for Resale

† BUCKET - Several different buckets and other attachments are available for the Bobcat loader backhoe.
 * ROPS, FOPS - Roll Over Protective Structure, Falling Object Protective Structure, per SAE j1040 and ISO 3471 and Falling Object Protective Structure per SAE J1043 and ISO 3449, Level 1.

B-19952
B-19931

SAFETY & MAINTENANCE

SAFETY & MAINTENANCE

| | |
|---|----------|
| AIR CLEANER SERVICE | 10-80-1 |
| Daily Check | 10-80-1 |
| Replacing The Air Filter Element | 10-80-1 |
| ALTERNATOR BELT | 10-160-1 |
| Adjusting The Alternator Belt | 10-160-1 |
| APPROVED LIFT ARM SUPPORT DEVICE | 10-20-1 |
| Installing The Approved Lift Arm Support Device | 10-20-1 |
| Removing The Approved Lift Arm Support Device | 10-20-2 |
| AXLE TOE-IN | 10-60-1 |
| Adjustment | 10-60-1 |
| BOOM LOCK PIN | 10-140-1 |
| Engaging And Disengaging The Pin | 10-140-1 |
| BOB-TACH | 10-150-1 |
| Inspection And Maintenance | 10-150-1 |
| ENGINE COOLING SYSTEM | 10-90-1 |
| Checking Coolant Level | 10-90-1 |
| Cleaning The Cooling System | 10-90-1 |
| Coolant Replacement | 10-90-2 |
| ENGINE COVER | 10-30-1 |
| ENGINE LUBRICATION SYSTEM | 10-110-1 |
| Checking Engine Oil | 10-110-1 |
| Oil Chart | 10-110-1 |
| Replacing The Oil And Filter | 10-110-2 |
| FRONT AXLE | 10-130-1 |
| Checking Oil Level | 10-130-1 |
| Draining Oil | 10-130-1 |
| FUEL SYSTEM | 10-100-1 |
| Filling The Fuel Tank | 10-100-1 |
| Fuel Filter | 10-100-1 |
| Fuel Specifications | 10-100-1 |
| Removing Air From The Fuel System | 10-100-3 |
| HYDRAULIC/HYDROSTATIC SYSTEM | 10-120-1 |
| Checking And Adding Fluid | 10-120-1 |
| Cleaning The Cooler | 10-120-2 |
| Replacing Hydraulic Fluid | 10-120-3 |
| Replacing Hydraulic/Hydrostatic Filter | 10-120-2 |

Continued On Next Page

Dealer Copy -- Not for Resale

SAFETY & MAINTENANCE

| | |
|---|----------|
| LIFTING AND BLOCKING THE LOADER BACKHOE | 10-10-1 |
| Procedure | 10-10-1 |
| LUBRICATING THE LOADER BACKHOE | 10-170-1 |
| REAR AXLE | 10-130-1 |
| Checking Oil Level | 10-130-1 |
| Draining Oil | 10-130-1 |
| SERVICE SCHEDULE | 10-70-1 |
| Chart | 10-70-1 |
| SWING LOCK PIN | 10-190-1 |
| Engaging The Swing Lock Pin | 10-190-1 |
| TIRE MAINTENANCE | 10-180-1 |
| Tire Mounting | 10-180-1 |
| Tire Pressure | 10-180-1 |
| Wheel Nuts | 10-180-1 |
| TOWING THE LOADER BACKHOE | 10-50-1 |
| Procedure | 10-50-1 |
| TRANSPORTING THE LOADER BACKHOE | 10-40-1 |
| Procedure | 10-40-1 |

Dealer Copy -- Not for Resale

LIFTING AND BLOCKING THE LOADER BACKHOE

Procedure



Instructions are necessary before operating or servicing machine. Read and understand the Operation & Maintenance Manual, Handbook and signs (decals) on machine. Follow warnings and instructions in the manuals when making repairs, adjustments or servicing. Check for correct function after adjustments, repairs or service. Untrained operators and failure to follow instructions can cause injury or death.

W-2003-0199

Figure 10-10-1



Read the removal and installation, disassembly and assembly, etc., completely to become familiar with the procedure before beginning [Figure 10-10-1].

Always park the loader backhoe on a level surface.

Stop the engine, and engage the parking brake.



Put jackstands under the front and rear axle before running the engine for service. Failure to use jackstands can allow the machine to fall or move and cause injury or death.

W-2461-0303

Figure 10-10-2

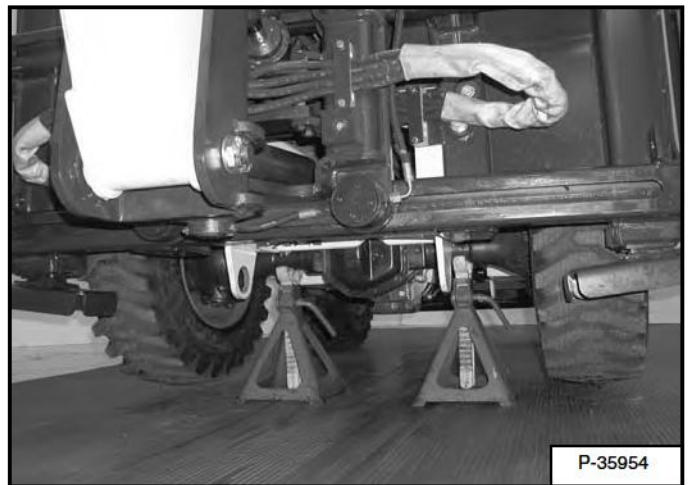

Lift the rear of the loader backhoe and install jackstands [Figure 10-10-2].

Figure 10-10-3



Lift the front of the loader backhoe and put jackstands under the axle [Figure 10-10-3].

Note: Make sure the jackstands do not touch the tires.

Dealer Copy -- Not for Resale

APPROVED LIFT ARM SUPPORT DEVICE

Most maintenance and service work can be done with the lift arms lowered. If the lift arms are raised, use the following procedures to install and remove the approved lift arm support device:



Never work on a machine with the lift arms up unless the lift arms are secured by an approved lift arm support device. Failure to use an approved lift arm support device can allow the lift arms or attachment to fall and cause injury or death.

W-2059-0598



Service lift arm support device if damaged or if parts are missing. Using a damaged lift arm support or with missing parts can cause lift arms to drop causing injury or death.

W-2271-1197

Installing The Approved Lift Arm Support Device

Remove the bucket or attachment from the loader.

Figure 10-20-1

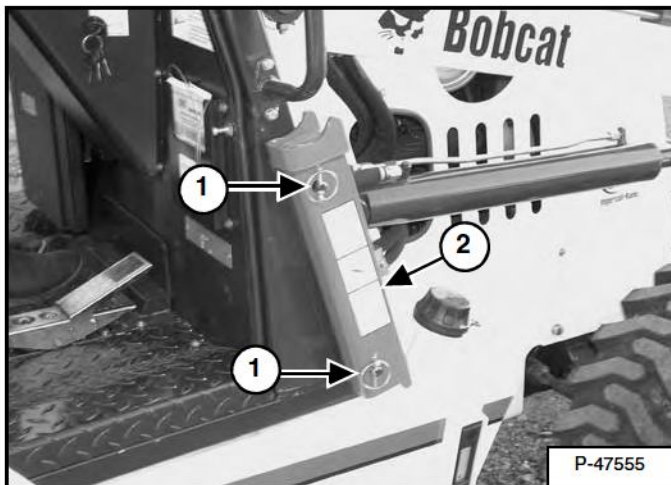

Remove the 2 pins (Item 1) and remove the approved lift arm support device (Item 2) [Figure 10-20-1] from the storage position.

Start the engine and raise the lift arms fully. Stop the engine.

Figure 10-20-2

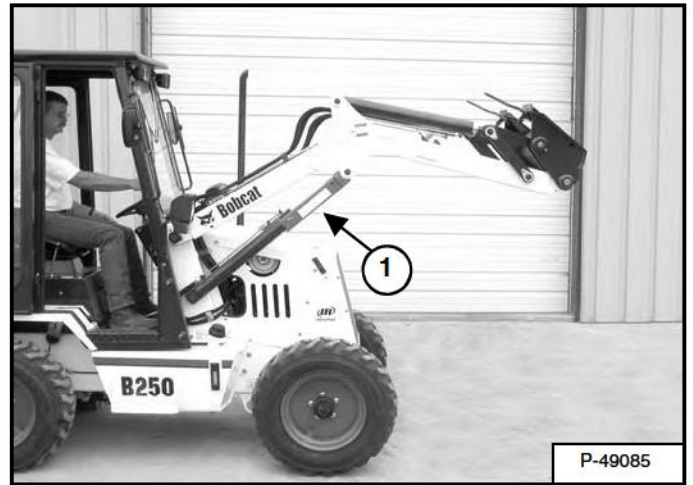

Install the approved lift arm support device (Item 1) [Figure 10-20-2] over the lift cylinder rod.

Figure 10-20-3



Lower the lift arms slowly until the approved lift support device is held securely [Figure 10-20-3].

Dealer Copy -- Not for Resale

APPROVED LIFT ARM SUPPORT DEVICE (CONT'D)

Removing The Approved Lift Arm Support Device

Figure 10-20-4

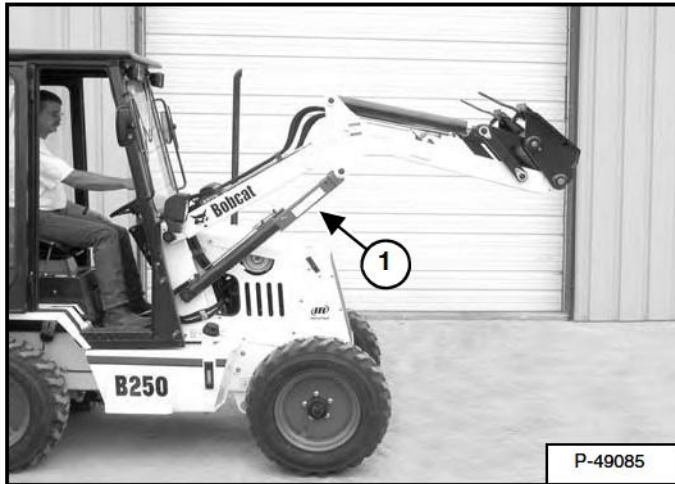

Start the engine, and raise the lift arms approximately 2 inches (51 mm). Stop the engine and exit the loader backhoe.

Remove the approved lift arm support device (Item 1) [Figure 10-20-4].

Lower the lift arms fully.

Exit the loader backhoe.

Figure 10-20-5

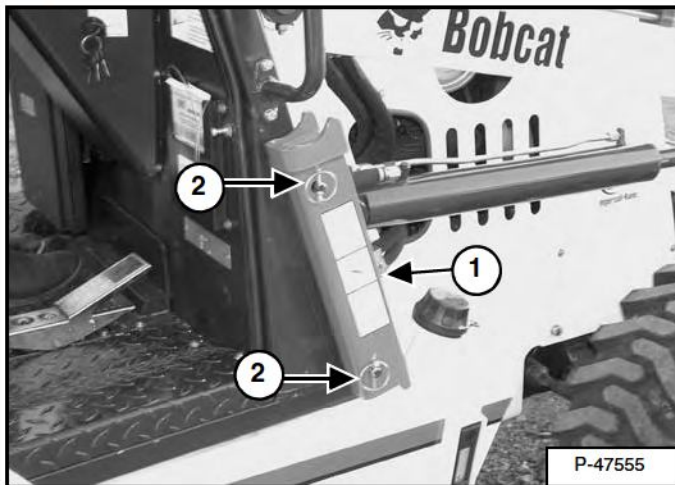

Put the approved lift arm support device (Item 1) in the storage position. Install the two retaining pins (Item 2) [Figure 10-20-5].

ENGINE COVER

Figure 10-30-1

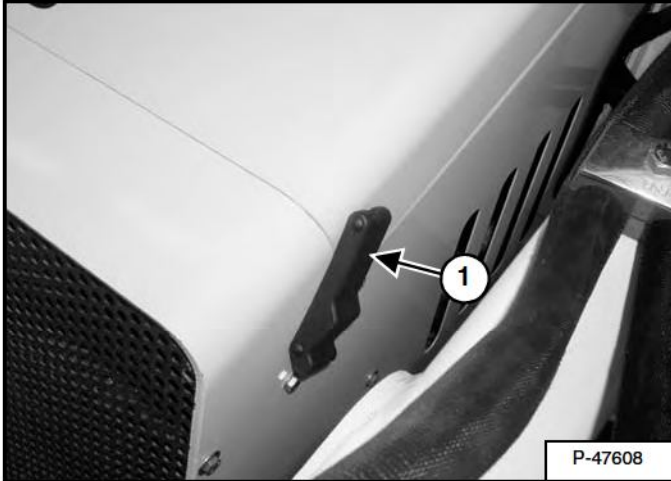

Open the latch (Item 1) [Figure 10-30-1] on each side of the engine cover.

Figure 10-30-2

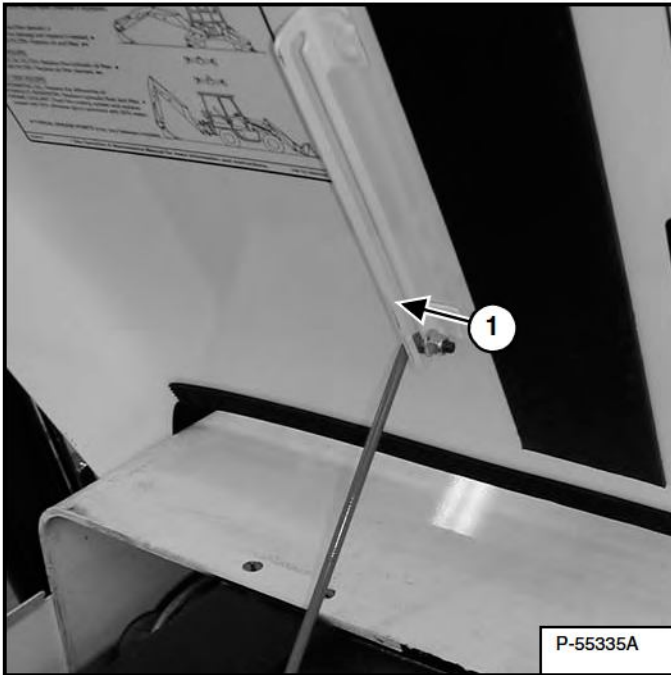

Raise the engine cover until the support rod (Item 1) [Figure 10-30-2] is in the locked position.

Figure 10-30-3

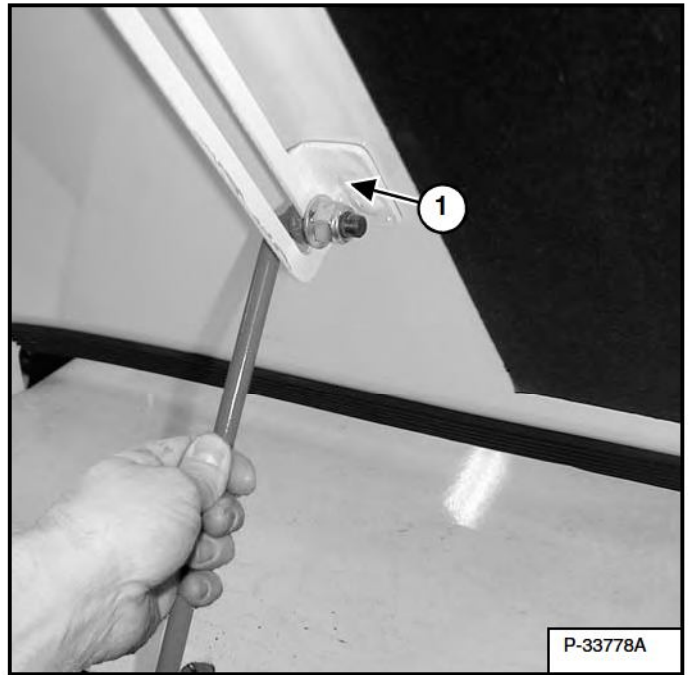

To lower the engine cover, slightly raise the engine cover and pull the support rod (Item 1) [Figure 10-30-3] forward. Lower the engine cover fully and install latches (Item 1) [Figure 10-30-1].

Dealer Copy -- Not for Resale

TRANSPORTING THE LOADER BACKHOE

Procedure



Adequately designed ramps of sufficient strength are needed to support the weight of the machine when loading onto a transport vehicle. Wood ramps can break and cause personal injury.

W-2058-0494

Be sure the transport and towing vehicles are of adequate size and capacity. (See LOADER BACKHOE SPECIFICATIONS on Page SPEC-10-1) for weight of the loader backhoe.)

Figure 10-40-1



The rear of the trailer must be blocked or supported (Item 1) [Figure 10-40-1] when loading or unloading the loader backhoe to prevent the front end of the trailer from raising up.

Use the following procedure to secure the loader backhoe to the transport vehicle to prevent the loader backhoe from moving during sudden stops or when going up or down slopes.

- Lower the loader bucket.
- Lower the backhoe bucket.
- Stop the engine.
- Engage the parking brake.

TRANSPORTING THE LOADER BACKHOE (CONT'D)

Procedure (Cont'd)

Figure 10-40-2

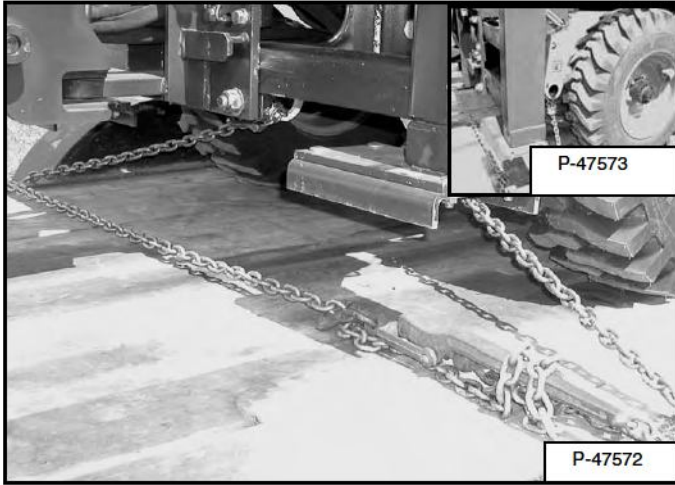

Figure 10-40-3

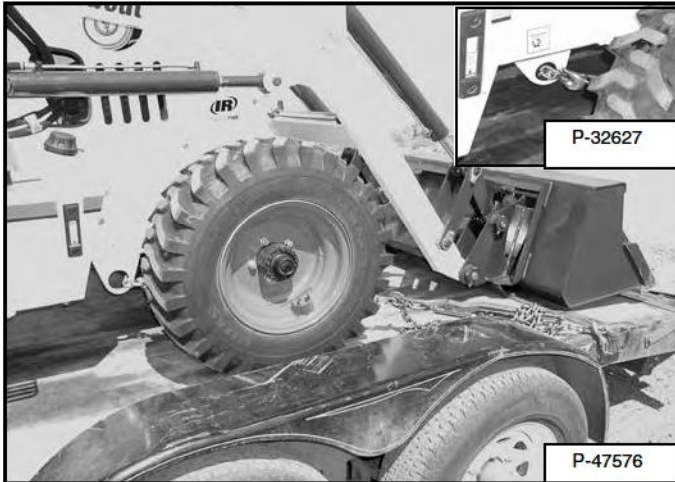
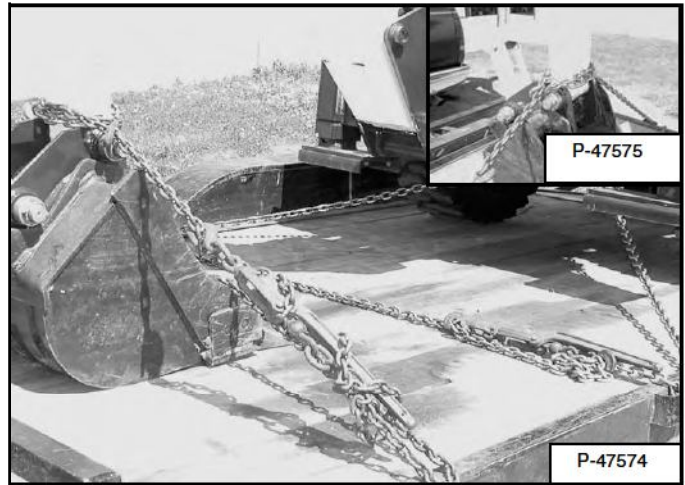

Figure 10-40-4



- Install chains at the rear of the machine [Figure 10-40-2] front of the machine [Figure 10-40-3] and at the backhoe [Figure 10-40-4].
- Fasten each end of the chain to the transport vehicle.

NOTE: For height restrictions the boom transport pin and swing locking pin must not be engaged when transporting the loader backhoe on a trailer. The backhoe boom must be lowered onto the trailer bed and chained.

TOWING THE LOADER BACKHOE

Procedure

Place blocks in front and behind rear wheels.

Figure 10-50-1

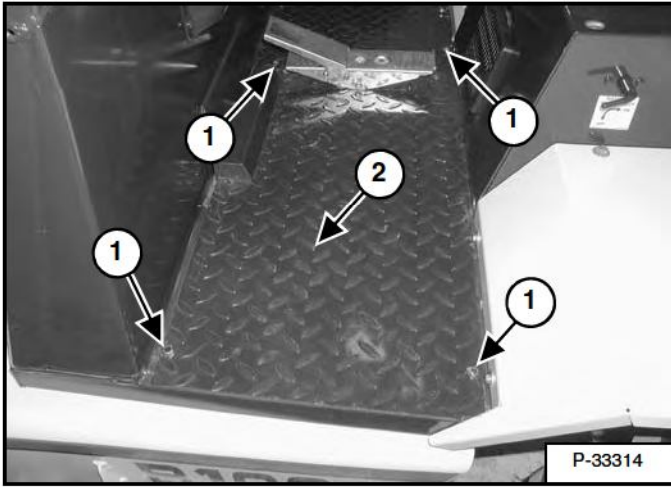

Remove the 4 mounting bolts (Item 1) and floor cover (Item 2) [Figure 10-50-1].

Figure 10-50-2

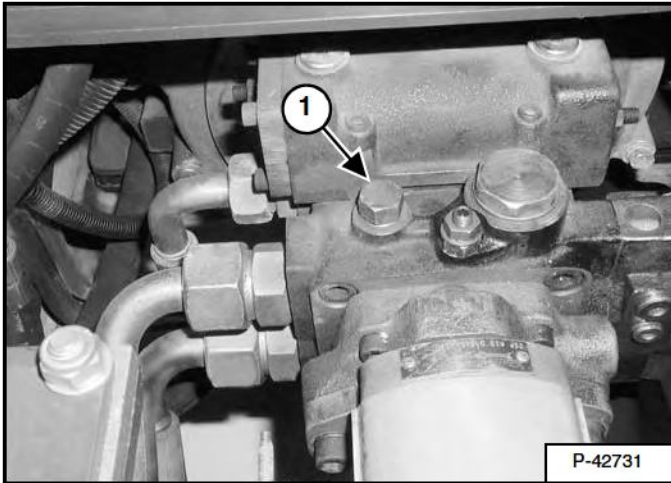

Loosen the tow valve (Item 1) [Figure 10-50-2].

Figure 10-50-3

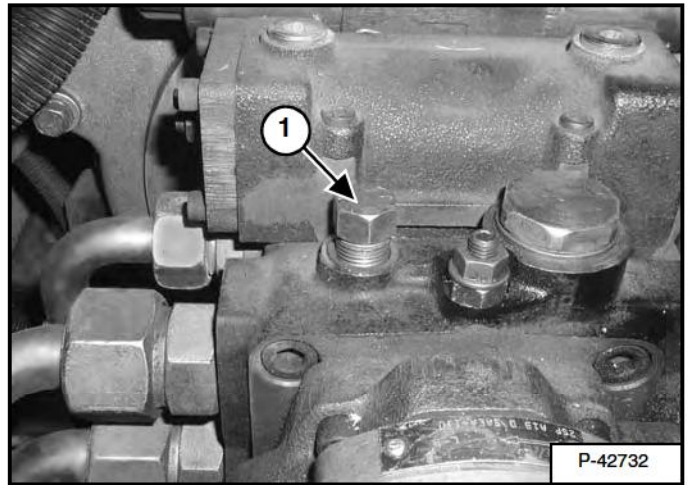

Rotate the tow valve (Item 1) [Figure 10-50-3] counterclockwise approximately 3 turns.

Figure 10-50-4

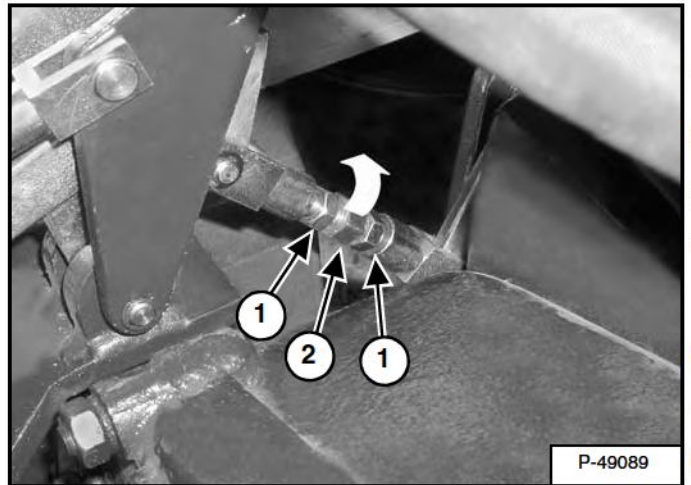

Loosen the 2 jam nuts (Item 1) and turn the parking brake linkage (Item 2) [Figure 10-50-4] approximately 2 turns. (Record the exact amount of turns on the parking brake linkage (Item 2). When putting the machine back in service, you must turn the parking brake linkage back to its original setting.)

To prevent damage to the loader backhoe hydrostatic system, the loader backhoe must be towed only a short distance at a low speed. (Example: Moving the loader backhoe onto a transport vehicle.)

The towing chain (or cable) must be rated at 1-1/2 times the weight of the loader. (See LOADER BACKHOE SPECIFICATIONS on Page SPEC-10-1.)

NOTE: Be sure to retighten the tow valve and readjust the parking brake linkage before operating the loader backhoe after towing.

Dealer Copy -- Not for Resale

AXLE TOE-IN

Adjustment

Raise the lift arms and install the approved lift arm support device. (See Installing The Approved Lift Arm Support Device on Page 10-20-1.)



Never work on a machine with the lift arms up unless the lift arms are secured by an approved lift arm support device. Failure to use an approved lift arm support device can allow the lift arms or attachment to fall and cause injury or death.

W-2059-0598

The front axle and rear axle toe-in adjustment procedure is the same. The front axle toe-in procedure is shown.

Figure 10-60-1

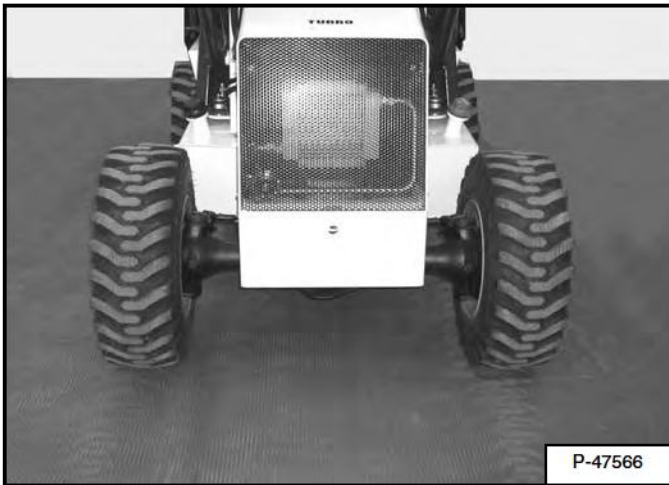

Turn the steering wheel until the front wheels are positioned as shown [Figure 10-60-1].

Figure 10-60-2

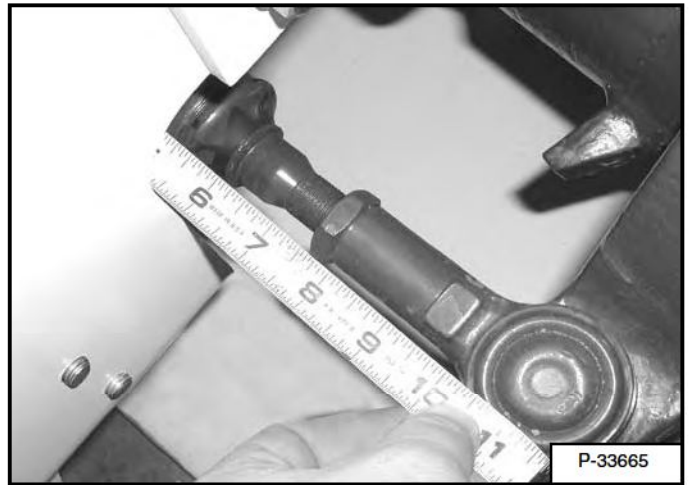

Measure the exposed part of the cylinder rod on each side of the steering cylinder housing making sure they are the same length [Figure 10-60-2].

Figure 10-60-3

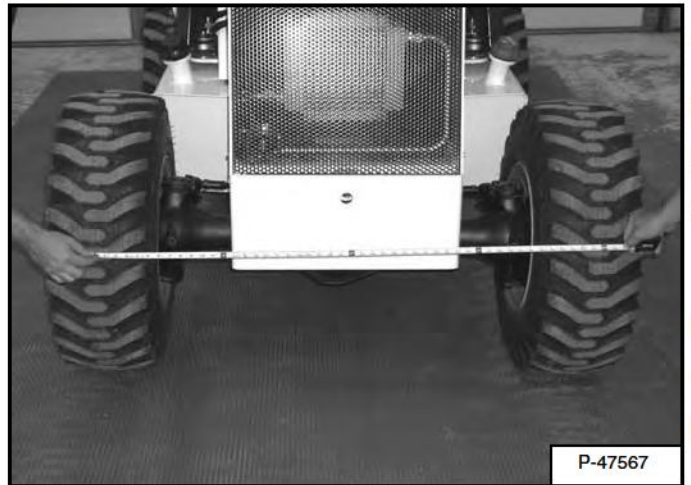

Measure the distance between the centerline on the front of the tires and compare it to the measurement taken from the centerline on the backside of the tires [Figure 10-60-3]. The measurement must be equal.

Dealer Copy -- Not for Resale

AXLE TOE-IN (CONT'D)

Adjustment (Cont'd)

Figure 10-60-4

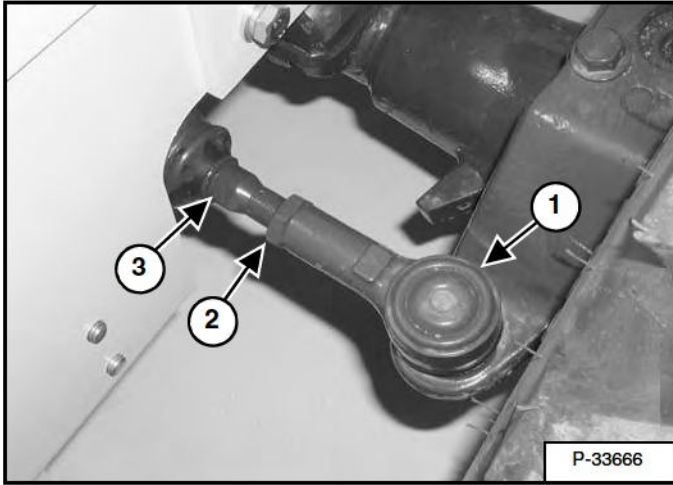

If measurement is not the same, adjust the tie rod end (Item 1) (both sides) by loosening the jam nut (Item 2). Loosen or tighten the rod (Item 3) [Figure 10-60-4] on both sides until the measurement is the same.

SERVICE SCHEDULE

Chart

Maintenance work must be done at regular intervals. Failure to do so will result in excessive wear and early failures. The service schedule is a guide for correct maintenance of the Bobcat Loader Backhoe.

| | |
|---|--|
|  <h2 style="margin: 0;">WARNING</h2> | <p>Instructions are necessary before operating or servicing machine. Read and understand the Operation & Maintenance Manual, Operator's Handbook and signs (decals) on machine. Follow warnings and instructions in the manuals when making repairs, adjustments or servicing. Check for correct function after adjustments, repairs or service. Untrained operators and failure to follow instructions can cause injury or death.</p> <p style="text-align: right; font-size: small;">W-2003-0199</p> |
|---|--|

| SERVICE SCHEDULE | | HOURS | | | | | | |
|--|---|-------|----|-----|-----|-----|-----|--------|
| ITEM | SERVICE REQUIRED | 8-10 | 50 | 100 | 200 | 250 | 500 | ● 1000 |
| Engine Oil | Check the engine oil level and add as needed. Do not overfill. | | | | | | | |
| Hydraulic Fluid | Check hydraulic fluid level and add as needed. | | | | | | | |
| Fuel Filter | Remove trapped water (if equipped with a water separator). | | | | | | | |
| Engine Air System | Check condition indicator and empty dust cup as needed. Check for leaks and damaged components. | | | | | | | |
| Engine Cooling System | Clean debris from oil cooler, radiator & grill. Check coolant level. | | | | | | | |
| Lift Arms, Cyl., Bob-Tach Pivot Pins, Wedges, Etc. | Lubricate all machinery pivots with multi-purpose lithium based grease. See illustrations. | | | | | | | |
| X-Change® System | Check for loose or damaged parts. Torque X-Change® bolts to 130 ft.-lb. (177 N•m) (If Equipped with Bolt On X-Change) | | | | | | | |
| Tires | Check for wear, damage and ensure proper size and inflation pressure. | | | | | | | |
| Seat Belt | Check the condition of seat belt and mounting hardware. Repair or replace as needed. | | | | | | | |
| Mirrors | Clean and adjust as necessary | | | | | | | |
| Steering valve | Check and adjust wheel alignment as required. | | | | | | | |
| Safety Signs and Safety Treads | Check for and replace any damaged and/or signs (decals) and safety treads. | | | | | | | |
| Operator Canopy/Cab (ROPS/FOPS) | Check the fastening bolts, washers and nuts. Check the condition of the canopy/cab. | | | | | | | |
| Indicators and Lights | Check for correct operation of all indicators and lights. | | | | | | | |
| Parking Brake | Check operation and have dealer adjust if required. | | | | | | | |
| PRESS TO DRIVE System | Check for proper function. | | | | | | | |
| Backup Alarm | Check operation. Alarm must sound when moving in the reverse direction. Repair or replace as required. | | | | | | | |
| Operator Area | Clean brake pedal, engine speed control pedal and footrest area. | | | | | | | |
| General | Repair broken or loose parts. Check engine area and keep clean of flammable material. | | | | | | | |
| Hydraulic Fluid, Hoses and Tubelines | Check fluid level & add as needed. Check for damage and leaks. Repair or replace as needed. | | | | | | | |
| Front & Rear Differential | Check oil level. Add oil as needed. | | | | | | | |
| Wheel Nuts | Check for loose wheel nuts and tighten. See LOADER BACKHOE SPECIFICATIONS on Page SPEC-10-1 | * | | | | | | |
| Inline Fuel Filter | Replace inline filter (if equipped). | | ■ | | | | | |
| Battery | Check battery for damage. Check cables, connections and electrolyte level. Add distilled water as needed. | | | | | | | |
| Spark Arrestor Muffler | Empty the spark chamber (if equipped). | | | | | | | |
| Engine Oil and Filter | Replace oil & filter. Use CD or better grade oil and Bobcat filter. | | ■ | | | | | |
| Fan/Alternator Belt | Check for damage and adjust tension as needed. | | ■ | | | | | |
| Fuel Filter | Replace filter element. | | | | | | | |
| Steering King Pins | Lubricate with multi-purpose lithium based grease. | | | | | | | |
| Hydraulic Oil Filter | Replace the filter element. | | ■ | | | | | |
| Engine Cooling System | Flush the cooling system and add new coolant. | | | | | | | |
| Hydraulic Reservoir | Replace the fluid and the filter. | | | | | | | |
| Differential Oil | Replace the front and rear differential oil. | | | | | | | |

- * Check wheel nut torque every 8 hours for the first 24 hours.
- Or every 12 months.
- Service at the first 50 hours, then as scheduled.

Dealer Copy -- Not for Resale

AIR CLEANER SERVICE

See SERVICE SCHEDULE on Page 10-70-1 for the correct service interval.

WARNING

Never work on a machine with the lift arms up unless the lift arms are secured by an approved lift arm support device. Failure to use an approved lift arm support device can allow the lift arms or attachment to fall and cause injury or death.

W-2059-0598

Daily Check

Figure 10-80-1

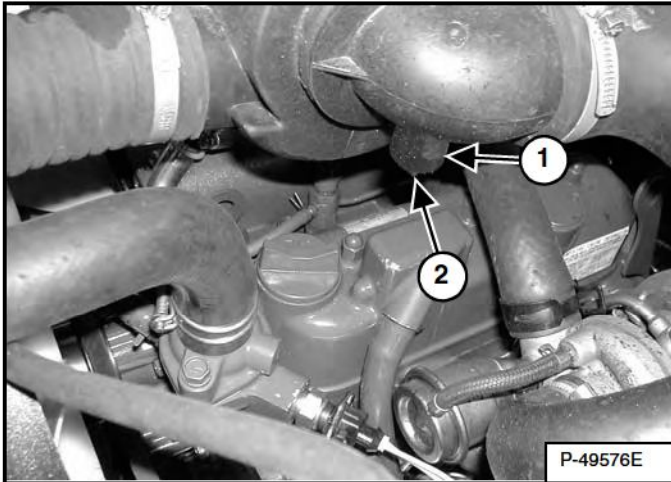

Check the condition indicator (Item 1) [Figure 10-80-1]. If the red ring shows in the condition indicator, the filter element needs to be replaced.

If the red ring does not show, no air filter element service is needed.

After the air filter element has been replaced, press the button (Item 2) [Figure 10-80-1] to reset the condition indicator.

Replacing The Air Filter Element

Outer Filter

Raise the loader lift arms and install the approved lift arm support device. (See Installing The Approved Lift Arm Support Device on Page 10-20-1.)

Open the engine cover. (See ENGINE COVER on Page 10-30-1.)

Figure 10-80-2

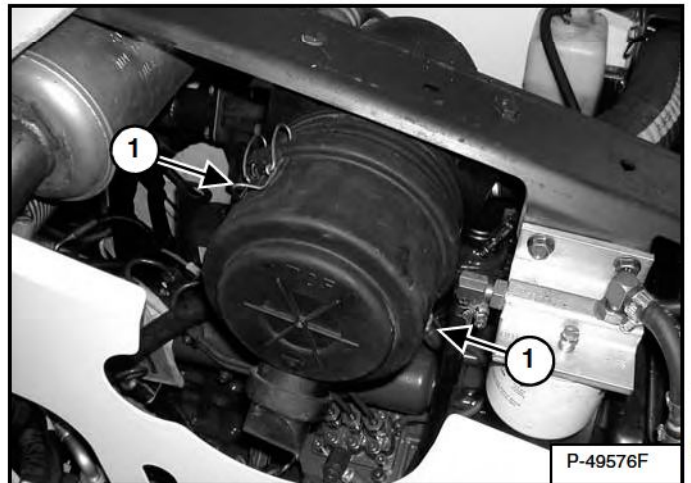

Pull out on the air cleaner cover clamps (Item 1) [Figure 10-80-2].

Figure 10-80-3

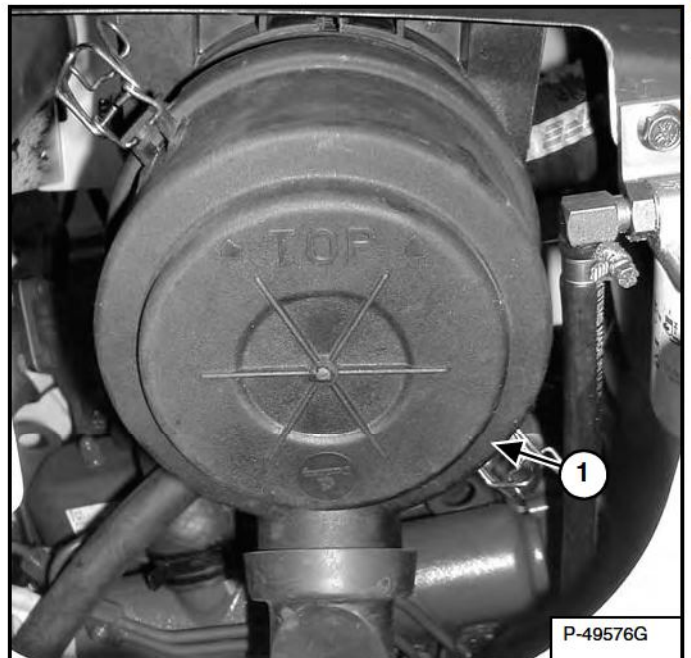

Pull the cover (Item 1) [Figure 10-80-3] outward to remove.

Dealer Copy -- Not for Resale

AIR CLEANER SERVICE (CONT'D)

Replacing The Air Filter Element (Cont'd)

Figure 10-80-4

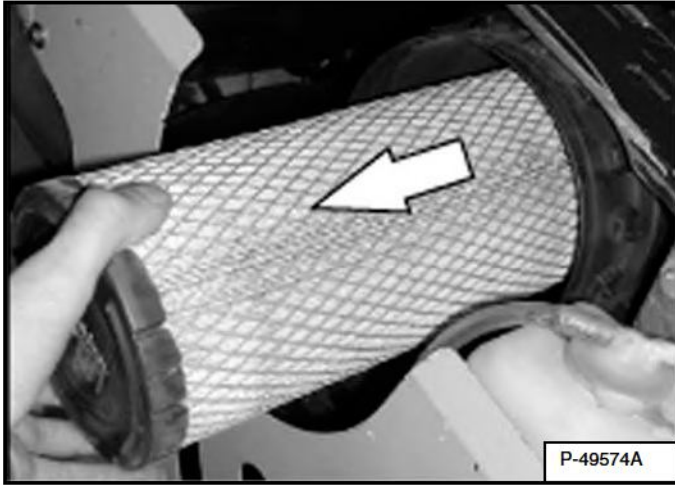

Remove the primary filter element by pulling outward on the element [Figure 10-80-4].

NOTE: Make sure all sealing surfaces are free of dirt and debris. Do Not use air pressure to clean the surfaces.

Install a new primary element into the housing [Figure 10-80-4].

Install the air cleaner cover [Figure 10-80-3].

Latch the air cleaner cover clamp (Item 1) [Figure 10-80-2].

Reset the condition indicator. (See [Figure 10-80-1].)

Inner Filter

Only replace the inner filter under the following conditions:

- Replace the inner filter every *third* time the outer filter is replaced.
- After the outer filter has been replaced, press the air cleaner indicator button (Item 2) [Figure 10-80-1]. Start the engine. Run at full RPM, then reduce engine speed and stop the engine. If the red ring shows in the condition indicator, replace the inner filter.

Figure 10-80-5

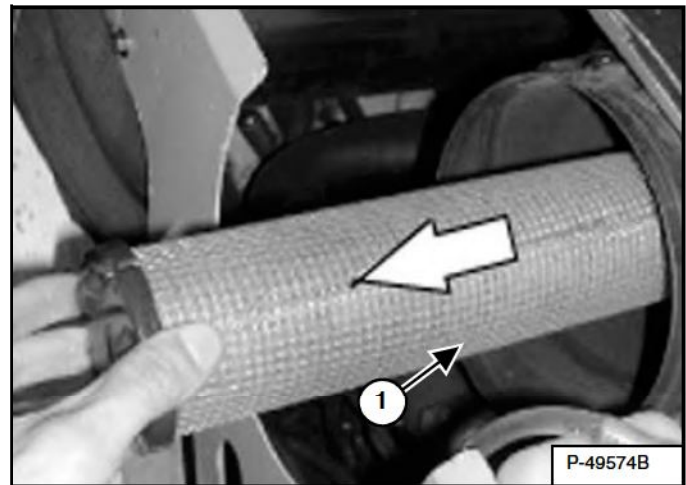

Remove the air cleaner cover, the outer filter and the inner filter (Item 1) [Figure 10-80-5].

NOTE: Make sure all sealing surfaces are free of dirt and debris. Do Not use air pressure to clean the surfaces.

Install the new inner filter.

Install the outer filter and the air cleaner cover.

Press the button on the condition indicator to reset the red ring.



Suggest:

If the above button click is invalid.

Please download this document first, and then click the above link to download the complete manual.

Thank you so much for reading

ENGINE COOLING SYSTEM

Check the coolant level every day before starting the engine for the work shift to prevent overheating, loss of performance or engine damage.

NOTE: Allow the cooling system and engine to cool before servicing the cooling system.

Cleaning The Cooling System

Figure 10-90-1

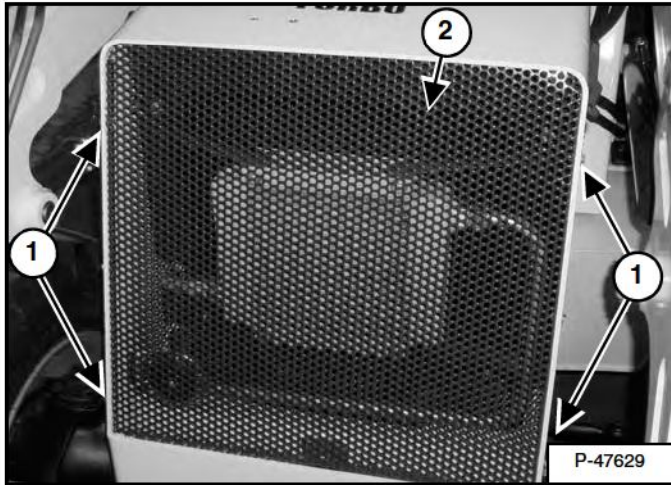

Use low air pressure or water pressure to clean the radiator/oil cooler. Be careful not to damage the radiator fins while cleaning.

If necessary, remove the 4 bolts (Item 1) and remove the grill screen (Item 2) [Figure 10-90-1] for easier access for cleaning the radiator. Reinstall the grill screen when finished.

Checking Coolant Level

Figure 10-90-2



Open the engine cover. (See ENGINE COVER on Page 10-30-1.)

Check the coolant level in the coolant recovery tank (Item 1) [Figure 10-90-2].

The coolant level must be between the full and low marks on the side of the coolant recovery tank when the engine is cold.

NOTE: The loader backhoe is factory filled with propylene glycol. Do Not mix propylene glycol with ethylene glycol. Always mix coolant in a separate container before adding to the coolant system.

Dealer Copy -- Not for Resale

<https://www.ebooklibonline.com>

Hello dear friend!

Thank you very much for reading.

Enter the link into your browser.

The full manual is available for immediate download.

<https://www.ebooklibonline.com>