

# X 325

## Excavator

## Service Manual

(S/N 511820001 & Above)

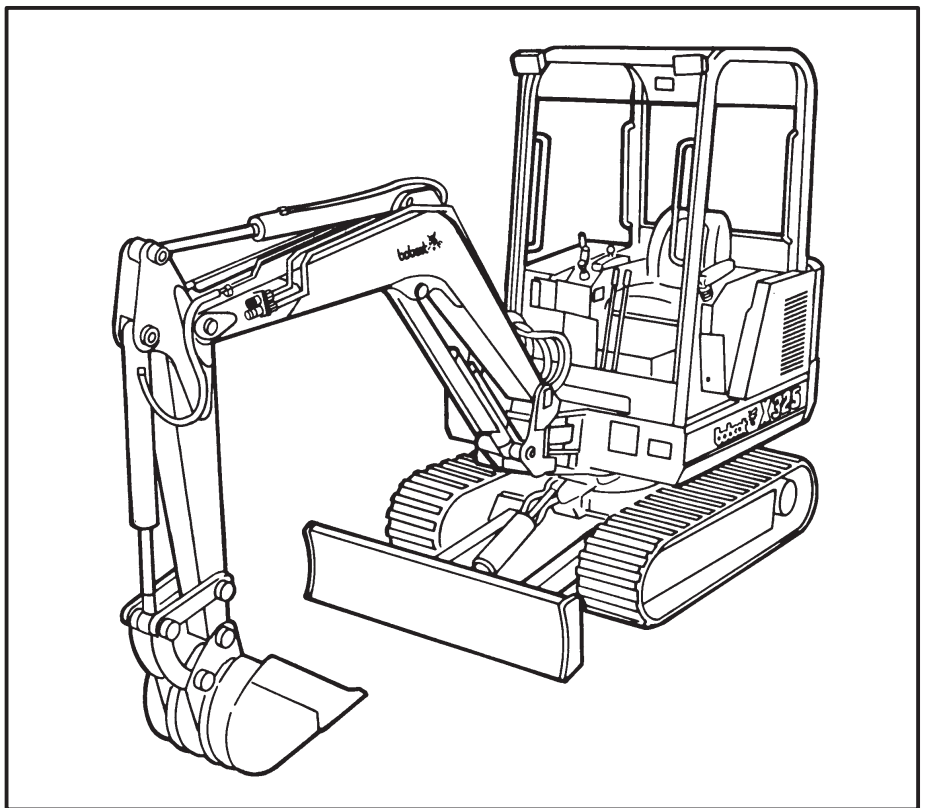

**MELROE**  
**INGERSOLL-RAND**

6722849(4-94)

Printed in U.S.A.



© Melroe Company 1994

# MAINTENANCE SAFETY



## WARNING

Instructions are necessary before operating or servicing machine. Read and understand the Operation & Maintenance Manual, Operator's Handbook and signs (decals) on machine. Follow warnings and instructions in the manuals when making repairs, adjustments or servicing. Check for correct function after adjustments, repairs or service. Untrained operators and failure to follow instructions can cause injury or death.

W-2003-0903



**Safety Alert Symbol:** This symbol with a warning statement, means: "Warning, be alert! Your safety is involved!" Carefully read the message that follows.

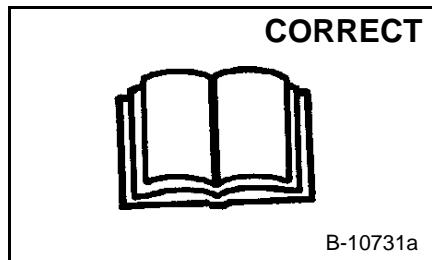

B-10731a

- ⚠ Never service the Bobcat Hydraulic Excavator without instructions.

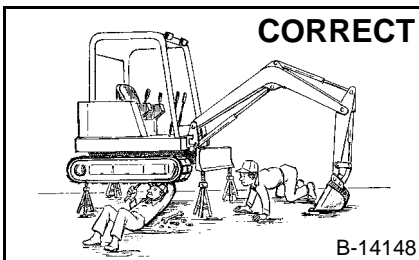

B-14148

- ⚠ Use the correct procedure to lift and support the excavator.
- ⚠ Always lift the blade fully before installing jackstands.

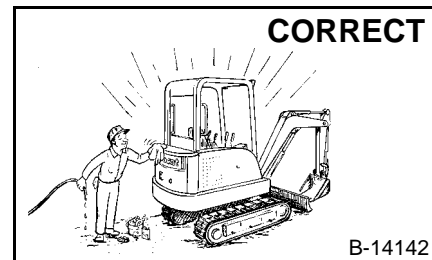

B-14142

- ⚠ Cleaning and maintenance are required daily.

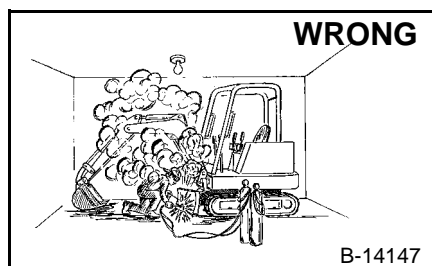

B-14147

- ⚠ Have good ventilation when welding or grinding painted parts.
- ⚠ Wear dust mask when grinding painted parts. Toxic dust and gas can be produced.



B-14141

- ⚠ Vent exhaust to outside when engine must be run for service.
- ⚠ Exhaust system must be tightly sealed. Exhaust Fumes can kill without warning.

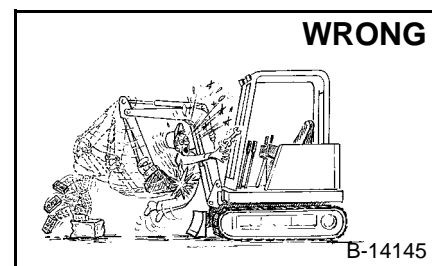

B-14145

- ⚠ Always lower the bucket and blade to the ground before doing any maintenance.
- ⚠ Never modify equipment or add attachments not approved by Bobcat Company.

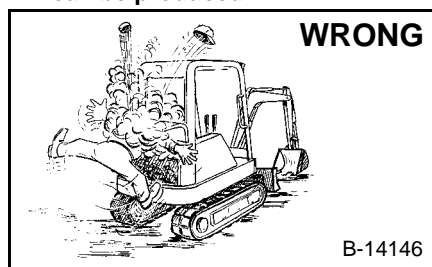

B-14146

- ⚠ Stop, cool and clean engine of flammable materials before checking fluids.
- ⚠ Never service or adjust machine with the engine running unless instructed to do so in the manual.
- ⚠ Avoid contact with leaking hydraulic fluid or diesel fuel under pressure. It can penetrate the skin or eyes.
- ⚠ Never fill fuel tank with engine running, while smoking or when near open flame.

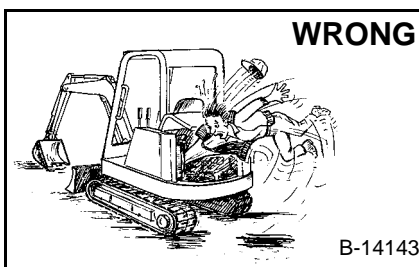

B-14143

- ⚠ Keep body, jewelry and clothing away from moving parts, electrical contact, hot parts and exhaust.
- ⚠ Wear eye protection to guard from battery acid, compressed springs, fluids under pressure and flying debris when engines are running or tools are used. Use eye protection approved for type of welding.
- ⚠ Keep rear door closed except for service. Close and latch door before operating the excavator.



B-6589

- ⚠ Lead-acid batteries produce flammable and explosive gases.
- ⚠ Keep arcs, sparks, flames and lighted tobacco away from batteries.
- ⚠ Batteries contain acid which burns eyes or skin on contact. Wear protective clothing. If acid contacts body, flush well with water. For eye contact flush well and get immediate medical attention.

Maintenance procedures which are given in the Operation & Maintenance Manual can be performed by the owner/operator without any specific technical training. Maintenance procedures which are **not** in the Operation & Maintenance Manual must be performed **ONLY BY QUALIFIED BOBCAT SERVICE PERSONNEL**. Always use genuine Bobcat replacement parts. The Service Safety Training Course is available from your Bobcat dealer.

## ALPHABETICAL INDEX

ACCUMULATOR .....	2-1	HYDRAULIC CONTROL VALVE (6-Spool)	
AIR CLEANER .....	7-1	DUKES VALVE (S/N 511820001-511820519) .....	2-1
AIR CLEANER SERVICE .....	1-1	HYDRAULIC CONTROL VALVE (3-Spool)	
ALTERNATOR .....	6-1	DUKES VALVE (S/N 511820001-511820519) .....	2-1
ARM .....	4-1	HYDRAULIC CONTROL VALVE (6-Spool)	
ARM CYLINDER .....	2-1	HUSCO VALVE (S/N 511820520 & Above) .....	2-1
		HYDRAULIC CONTROL VALVE (3-Spool)	
BATTERY (S/N 20001-20294) .....	6-1	HUSCO VALVE (S/N 511820520 & Above) .....	2-1
BATTERY (S/N 20295 & Above) .....	6-1	HYDRAULIC CYLINDER .....	2-1
BLADE .....	5-1	HYDRAULIC EXCAVATOR SPECIFICATIONS .....	8-1
BLADE CYLINDER .....	2-1	HYDRAULIC FILTER ASSEMBLY .....	2-1
BOOM .....	4-1	HYDRAULIC PUMP .....	2-1
BOOM CYLINDER .....	2-1	HYDRAULIC RESERVOIR .....	2-1
BOOM SWING BRACKET .....	4-1	HYDRAULIC SERVICE INFORMATION .....	2-1
BOOM SWING CYLINDER .....	2-1	HYDRAULIC SYSTEM .....	1-1
BUCKET .....	4-1		
BUCKET CYLINDER .....	2-1	INSPECTION COVER .....	4-1
BUCKET TEETH .....	4-1	INSTRUMENT PANEL .....	6-1
CAB .....	4-1	JOYSTICK .....	3-1
CAB/CANOPY REAR COVER .....	4-1	JOYSTICK CONTROL CHANGE .....	2-1
CAB ELECTRICAL (Cab Option) .....	6-1		
CENTER FLOOR PANEL .....	4-1	LEFT CONSOLE .....	3-1
CENTER SWIVEL JOINT .....	4-1	LEFT HAND SIDE COVER .....	4-1
CONSOLE SWITCHES .....	6-1	LEFT JOYSTICK .....	3-1
CONTROL LEVERS .....	3-1	LUBRICATION OF THE HYDRAULIC EXCAVATOR	1-1
COOLING SYSTEM .....	1-1		
CORNER POST .....	4-1	MAIN RELIEF VALVES HUSCO VALVE .....	2-1
COUNTERBALANCE VALVE		MUFFLER .....	7-1
(S/N 511820520 & Above) .....	4-1		
COUNTERWEIGHTS .....	4-1	OIL COOLER .....	2-1
CRANKSHAFT AND BEARINGS .....	7-1	OIL SPECIFICATIONS .....	8-1
CROSS PORT RELIEF VALVE			
(S/N 511820001-511820519) .....	4-1	PORT BLOCK .....	2-1
CYLINDER HEAD .....	7-1	PORT RELIEF VALVES HUSCO VALVE .....	2-1
CYLINDER LINERS .....	7-1		
		RADIATOR .....	7-1
DOMELIGHT .....	6-1	REAR FLOOR PANEL .....	4-1
DRIVE MOTOR .....	5-1	RIGHT CONSOLE .....	3-1
		RIGHT JOYSTICK .....	3-1
ELECTRIC FUEL PUMP .....	7-1	ROPS CANOPY .....	4-1
ELECTRICAL SYSTEM .....	6-1		
ENGINE .....	7-1	SEAT AND MOUNTING FRAME .....	4-1
ENGINE COMPRESSION .....	7-1	SERVICE SCHEDULE .....	1-1
ENGINE COVER .....	1-1, 4-1	STARTER .....	6-1
ENGINE FLYWHEEL .....	7-1	SWING GEAR BOX ASSEMBLY .....	4-1
ENGINE LUBRICATION SYSTEM .....	1-1	SWING MOTOR .....	4-1
ENGINE SPECIFICATIONS .....	8-1	SWING MOTOR COVER .....	4-1
FINAL DRIVE CASE .....	1-1	TIMING GEAR, CAMSHAFT AND OIL PUMP .....	7-1
FOOT PEDAL AND STEERING LEVERS .....	3-1	TIMING GEAR COVER .....	7-1
FRONT ENGINE COVER .....	4-1	TOOL BOX .....	4-1
FUEL, COOLANT AND LUBRICANTS .....	8-1	TRACK .....	5-1
FUEL FILTER .....	7-1	TRACK FRAME .....	5-1
FUEL INJECTION PUMP .....	7-1	TRACK IDLER .....	5-1
FUEL INJECTOR NOZZLES .....	7-1	TRACK ROLLER .....	5-1
FUEL LEVEL SENDER .....	6-1	TROUBLESHOOTING .....	6-1, 7-1
FUEL SYSTEM .....	1-1		
FUEL TANK .....	4-1	UPPER STRUCTURE AND SWING CIRCLE GEAR	4-1
		USING A BOOSTER BATTERY (JUMP STARTING)	1-1
GLOW PLUGS .....	7-1	VALVE CLEARANCE .....	7-1
		WATER PUMP .....	7-1

**<https://www.ebooklibonline.com>**

Hello dear friend!

Thank you very much for reading.

Enter the link into your browser.





The full manual is available for immediate download.

**<https://www.ebooklibonline.com>**

# FOREWORD

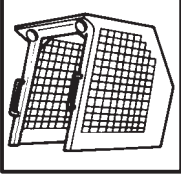
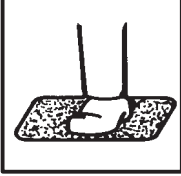
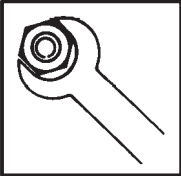
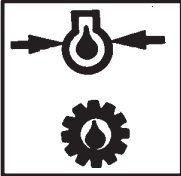
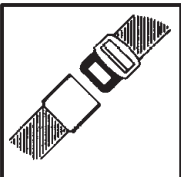
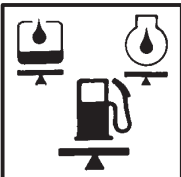
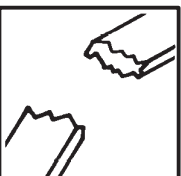
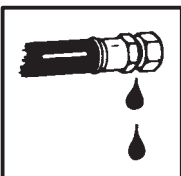
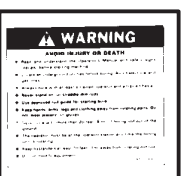
This manual is for the Bobcat hydraulic excavator mechanic. It provides necessary servicing and adjustment procedures for the hydraulic excavator and its component parts and systems. Refer to the Operation & Maintenance Manual for operating instructions, starting procedure, daily checks, etc.

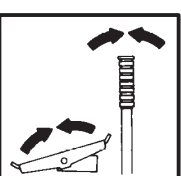
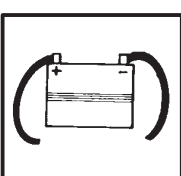
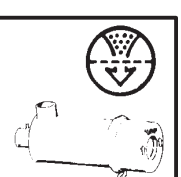
A general inspection of the following items must be made after the hydraulic excavator has had service or repair:

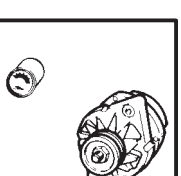
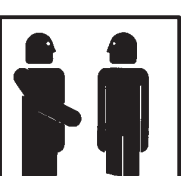
- |   |   |   |   |
|---|---|---|---|
| <p>1. Check that the ROPS/FOPS (Including sidescreens) is in good condition and is not modified.</p>  |    | <p>9. Safety treads must in good condition.</p>   |    |
| <p>2. Check that ROPS mounting hardware is tightened and is Melroe approved.</p>  |    | <p>10. Check for correct function of indicator lamps (Optional on some models).</p>                             |    |
| <p>3. The seat belt must be correctly installed, functional and in good condition.</p>  |    | <p>11. Check hydraulic fluid level, engine oil level and fuel supply.</p>                                       |    |
| <p>4. Inspect for loose or broken parts or connections.</p>   |   | <p>12. Inspect for fuel, oil or hydraulic fluid leaks.</p>  |   |
| <p>5. Machine signs must be legible and in the correct location.</p>  |  | <p>13. Lubricate the excavator.</p>   |  |
| <p>6. Steering levers, control levers and foot pedals must return to neutral. Check that foot pedals lock and control lever locks are in working condition.</p> |  | <p>14. Check the condition of the battery and cables.</p>   |  |
| <p>7. Inspect the air cleaner for damage or leaks. Check the condition of the element.</p>  |  | <p>15. Check for any field modifications not completed.</p>   |  |
| <p>8. Check the electrical charging system.</p>   |  | <p>Recommend to the owner that all necessary corrections be made before the machine is returned to service.</p> |  |

# CONTENTS

	Page Number
SAFETY INSTRUCTIONS .....	i
SERIAL NUMBER LOCATIONS .....	ii
DELIVERY REPORT .....	ii
HYDRAULIC EXCAVATOR IDENTIFICATION .....	iii
PREVENTIVE MAINTENANCE .....	1-1
HYDRAULIC SYSTEM .....	2-1
DRIVE SYSTEM .....	3-1
UPPER WORKS & SWING SECTION .....	4-1
MAIN FRAME & TRACKS .....	5-1
ELECTRICAL SYSTEM .....	6-1
ENGINE SERVICE .....	7-1
TECHNICAL DATA .....	8-1

**PREVENTIVE  
MAINTENANCE**

**HYDRAULIC  
SYSTEM**

**DRIVE  
SECTION**

**UPPER WORKS  
& SWING  
SECTION**

**MAIN FRAME  
& TRACKS**

**ELECTRICAL  
SYSTEM**

**ENGINE  
SERVICE**

**TECHNICAL  
DATA**

**CALIFORNIA  
PROPOSITION 65 WARNING**

Diesel engine exhaust and some of its constituents are known to the State of California to cause cancer, birth defects and other reproductive harm.

## SAFETY INSTRUCTIONS

# **WARNING**

**Instructions are necessary before operating or servicing machine. Read Operation & Maintenance Manual, Handbook and signs (decals) on machine. Follow warnings and instructions in the manuals when making repairs, adjustments or servicing. Check for correct function after adjustments, repairs or service. Failure to follow instructions can cause injury or death.**

W-2003-1289

The following publications provide information on the safe use and maintenance of the excavator and attachments:

- \* The Delivery Report is used to assure that complete instructions have been given to the new owner and that the machine is in safe operating condition.
- \* The Operation & Maintenance Manual delivered with the excavator gives operating information as well as routine maintenance and service procedures. It is a part of the excavator and must stay with the machine when it is sold. Replacement Operation & Maintenance Manuals can be ordered from your Bobcat Excavator dealer.
- \* The excavator has machine signs (decals) which instruct on the safe operation and care. The signs and their locations are shown in the Operation & Maintenance Manual. Replacement signs are available from your Bobcat Excavator dealer.
- \* The CIMA Safety Manual delivered with the excavator gives information for safe operating and standard signals.
- \* The Service Manual and Parts Manual are available from your dealer for use by mechanics to do shop-type service and repair work.

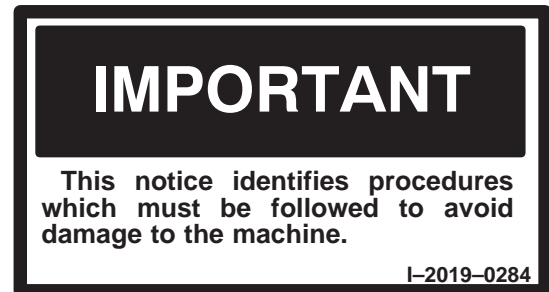

This safety message symbol is used for important safety messages. When you see this symbol, follow the safety message to avoid personal injury or death.

- \* Wear tight fitting clothing and any other required safety apparel when operating or servicing the excavator.
- \* Wear safety glasses when maintaining or servicing the excavator.
- \* Exhaust gases can kill, vent engine exhaust outdoors.
- \* Know where fire extinguisher and first aid kits are located and how to use them.
- \* Do not run the excavator where exhaust, arcs, sparks or hot components can contact flammable material, explosive dust or gases.
- \* Check fuel and hydraulic tubes, hoses and fittings for damage and leakage. Never use open flame or bare skin to check for leaks. Tighten or replace any parts that show leakage. Always clean fluid spills. Do not use gasoline or diesel fuel for cleaning parts. Use commercial nonflammable solvents.
- \* Do not use ether or starting fluids on an engine that has glow plugs. These starting aids can explode and injure you.
- \* Clean the excavator before doing any welding. Remove both battery cables (negative (-) cable first). Cover rubber hoses, battery and all other flammable parts. Keep a fire extinguisher near the excavator when welding.
- \* Have good ventilation when welding or grinding painted parts. Wear a dust mask when grinding painted parts. Toxic dust or gas can be produced.
- \* Stop the engine and let it cool before adding fuel. **NO SMOKING!**
- \* Use the procedures in this manual for installing, connecting and jump starting batteries.

## SERIAL NUMBER LOCATIONS

Always use the serial number of the machine when requesting service information or when ordering parts. Early or later models (identification made by serial number) may use different parts, or it may be necessary to use a different procedure in doing a specific service operation.

### HYDRAULIC EXCAVATOR SERIAL NUMBER

The excavator serial number is on the right front side of the machine frame [A].



### ENGINE SERIAL NUMBER

The engine serial number is located on the engine block, near the fuel injection pump [B].

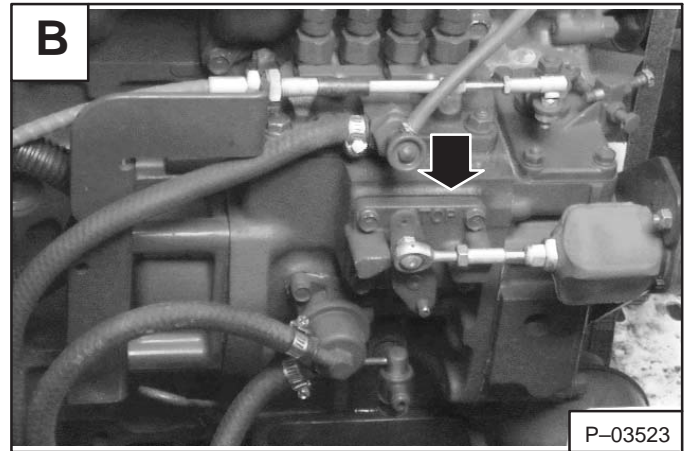

## DELIVERY REPORT

The Delivery Report items must be explained to the owner/operator by the dealer. The dealer is to fill out the form and the owner/operator signs the form to indicate his understanding [C].

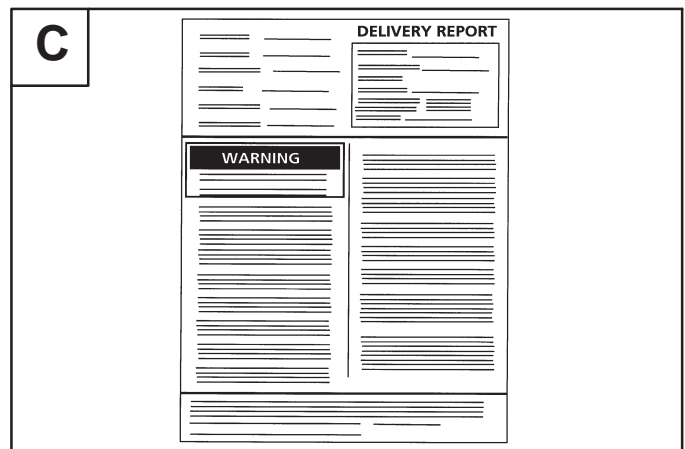

# HYDRAULIC EXCAVATOR IDENTIFICATION

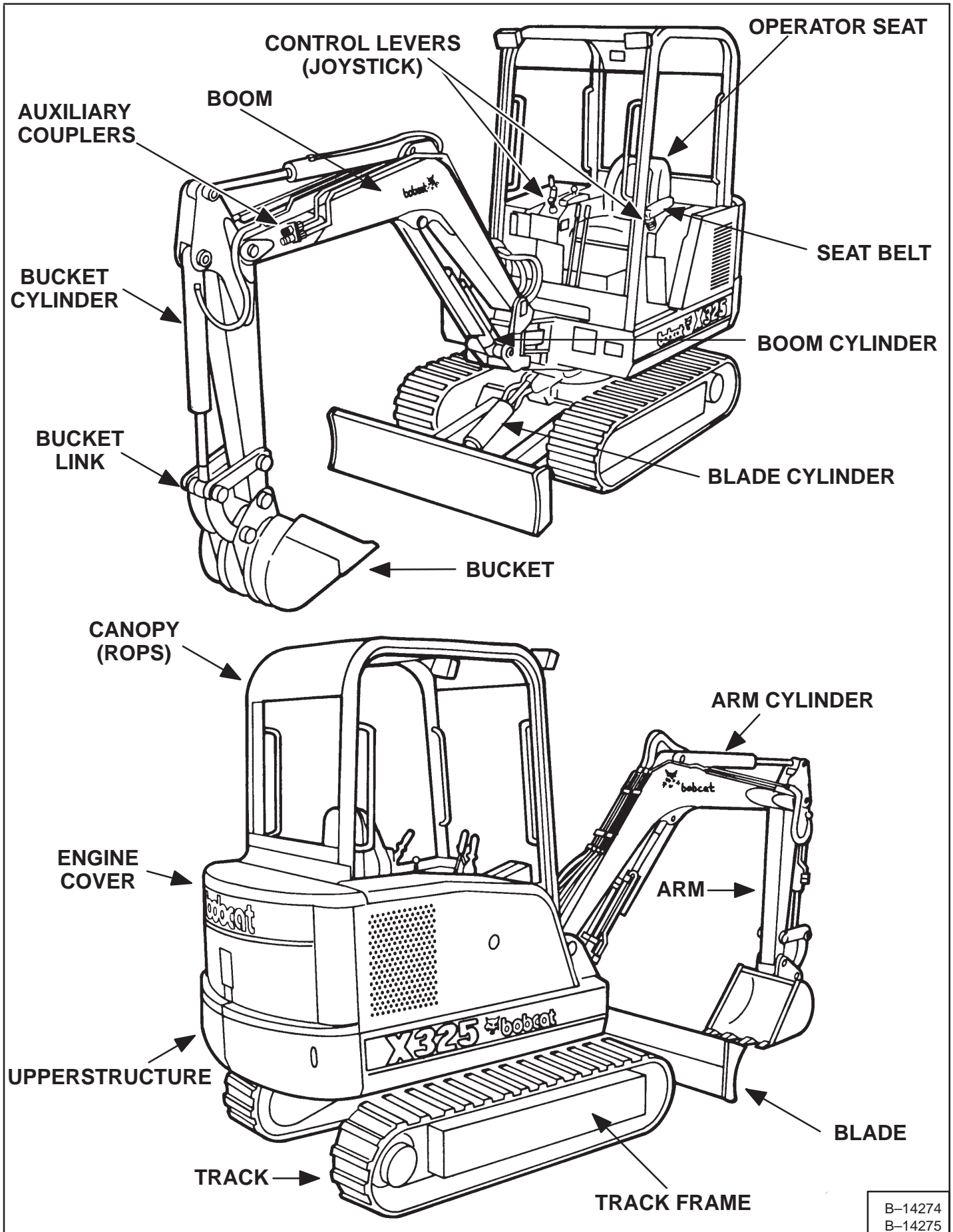

B-14274  
B-14275

# PREVENTIVE MAINTENANCE

## PREVENTIVE MAINTENANCE

Page  
Number

AIR CLEANER SERVICE	
Replacing The Filter Element .....	1-2
COOLING SYSTEM	
Coolant Level .....	1-7
Coolant Replacement .....	1-7
ENGINE COVER	
Procedure .....	1-2
ENGINE LUBRICATION SYSTEM	
Checking The Engine Oil .....	1-6
Engine Oil And Filter Replacement .....	1-6
FUEL SYSTEM	
Fuel Specifications .....	1-13
Fuel System Service .....	1-13
FINAL DRIVE CASE	
Checking Oil Level .....	1-4
Draining Final Drive Case .....	1-4
HYDRAULIC SYSTEM	
Checking And Adding Fluid .....	1-8
Hydraulic Reservoir .....	1-9
Replacement Of The Hydraulic Filter .....	1-8
LUBRICATION OF THE HYDRAULIC EXCAVATOR	
Procedure .....	1-11
SERVICE SCHEDULE	
Chart .....	1-1
USING A BOOSTER BATTERY (JUMP STARTING)	
Procedure .....	1-10

## SERVICE SCHEDULE

Maintenance work must be done at regular intervals. Failure to do so will result in excessive wear and early failures. The *SERVICE SCHEDULE* is a guide for correct maintenance of the Hydraulic Excavator.



## WARNING

Instructions are necessary before operating or servicing machine. Read Operation & Maintenance Manual, Handbook and signs (decals) on machine. Follow warnings and instructions in the manuals when making repairs, adjustments or servicing. Check for correct function after adjustments, repairs or service. Failure to follow instructions can cause injury or death.

W-2003-0797

SERVICE SCHEDULE		HOURS					
ITEM	SERVICE REQUIRED	8-10	50	100	250	500	1000
Engine Air Cleaner	Empty the dust cap. Replace the filter element only when the red ring shows in the indicator window, Check for leaks and damaged components.						
Engine Oil	Check the oil level & add oil as needed.						
Engine Coolant System	Check coolant level in recovery tank.						
Indicator Lights	Check for correct operation.						
Operator Canopy or Cab	Check the fastening bolts, nuts, & condition of cab.						
Seat Belt	Check the condition & that fasteners are tight.						
Safety Signs (Decals)	Check for damaged signs (decals) replace as needed.						
Tracks	Check & adjust tension.						
Hydraulic Reservoir	Check fluid level.						
All Machinery Pivot Points	Lubricate 20 grease fittings.						
Fuel Tank/Fuel Filter	Drain water & sediment from fuel tank/fuel filter.						
Swing Circle	Lubricate two grease fittings.						
Swing Pinion	Lubricate one grease fitting.						
Engine Oil & Filter	Replace oil & filter element.						
Alternator Belt	Check & adjust tension.		*				
Final Drive Case	Check fluid level & add oil as needed.						
Hydraulic Filter	Replace filter element.		*				
Fuel Filter	Replace filter element.						
Battery	Check & clean cable ends & check electrolyte level.						
Air Cleaner	Replace the filter element.						
Cooling System	Clean the radiator fins.						
Alternator & Starter	Check the condition.						
Engine Valve	Check engine valve clearance.				**		
Cooling System	Drain, flush & add new coolant to the cooling system.						***
Hydraulic Tank	Change the fluid, clean fill neck strainer.						
Final Drive Case	Change the oil.			**			
Clean Port Block Screen							

\* After the first 50 hours of machine operation do the following:

Replace the hydraulic filter.  
Check condition of alternator belt.

\*\* After the first 100 hours of machine operation do the following:

Change oil in final drive case.

\*\*\* Or Every 12 months

## ENGINE COVER

### Procedure



# WARNING

### AVOID INJURY

Never service or adjust the machine when the engine is running unless instructed to do so in this manual.

W-2012-0497

Keep the engine cover closed when operating the machine.

W-2141-0189

Open the engine cover to service the engine. Pull on the latch and lift the engine cover up until it is fully raised [A].

## AIR CLEANER SERVICE

### Replacing The Filter Element

See the *SERVICE SCHEDULE* Page 1-1 for the correct service interval.

Replace the filter element when the red ring shows in the window of the condition indicator [B].

**NOTE:** Push the button on the condition indicator and start the engine. If the red ring does not show, do not replace the filter element .

Service the air cleaner as follows:

1. Loosen the clamp on the dust cup [C].
2. Remove the dust cup. [D].

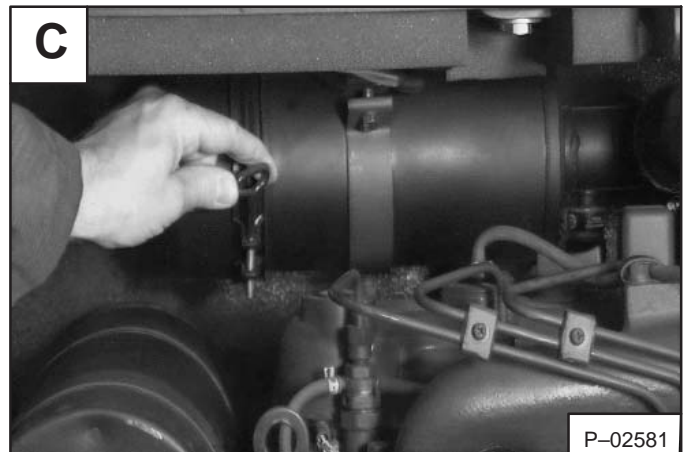
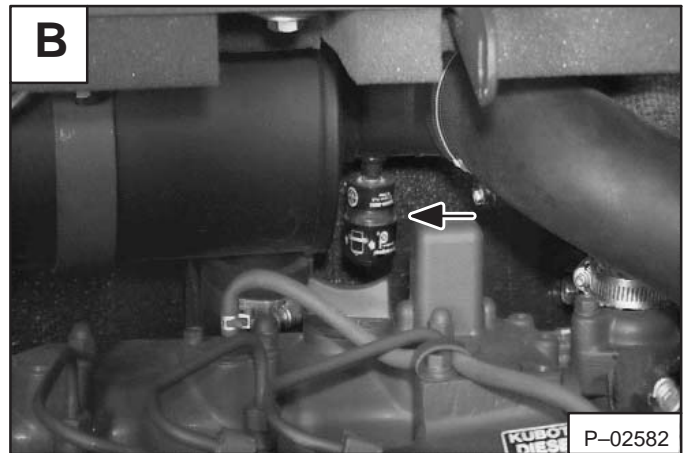

## AIR CLEANER SERVICE (Cont'd)

### Replacing The Filter Element (Cont'd)

3. Remove the rubber cup (Item 1) **[A]** to clean the dust cup.
  
4. Remove the wing nut (Item 1) **[B]**.
  
5. Remove the filter element **[C]**.
6. Check the air cleaner housing for damage.
7. Wipe the canister and the seal surface clean with a clean cloth. Do Not use compressed air.
8. Install a new filter element. Install and tighten the wing nut.
9. Install the dust cup so the arrow points up.
10. Check that all the air cleaner hose clamps are tight.
11. Push the button on the condition indicator so the red ring does not show.

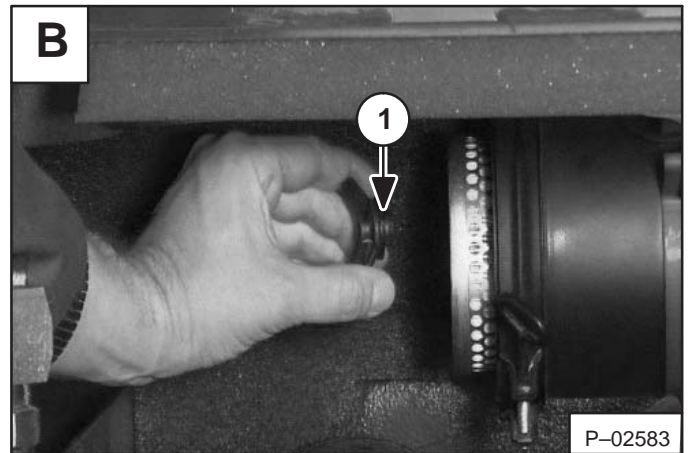
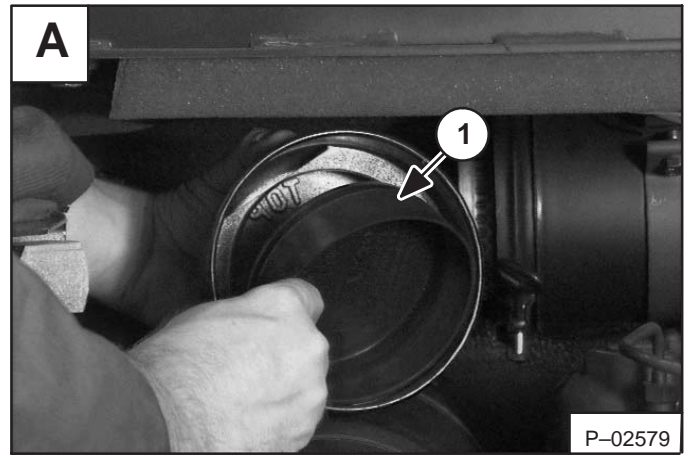

## FUEL SYSTEM

### Fuel Specification

Use Number 2 diesel fuel in the engine. During very cold temperatures, Number 1 fuel can be used (See Page 8–8).



## WARNING

Stop and cool the engine before adding fuel.  
**NO SMOKING!** Failure to obey warnings can cause an explosion or fire.

W-2063-0887

### Fuel System Service

The fuel level in the tank is indicated by the fuel gauge (Item 1) [A] when the engine is running.

Use the key to un-lock the fuel fill door [B].

Open the door.

Turn the fill cap (Item 1) [C] to remove it.

Use a clean, approved safety container to add fuel to the tank.

Add fuel only in an area that has a free movement of air and no flames or sparks. **NO SMOKING!**

After the tank is full, install and tighten the fuel fill cap.

Close and lock the fuel door.



## WARNING

Always clean up spilled fuel or oil. Keep heat, flames, sparks or lighted tobacco away from fuel and oil. Failure to use care around combustibles can cause explosion or fire which can result in injury or death.

W-2103-1285

**NOTE:** When the fuel level reaches the 1.7 gals. (6,5L.) fuel setting, the low fuel light (Item 2) [A] will come on to alert the operator of this condition.

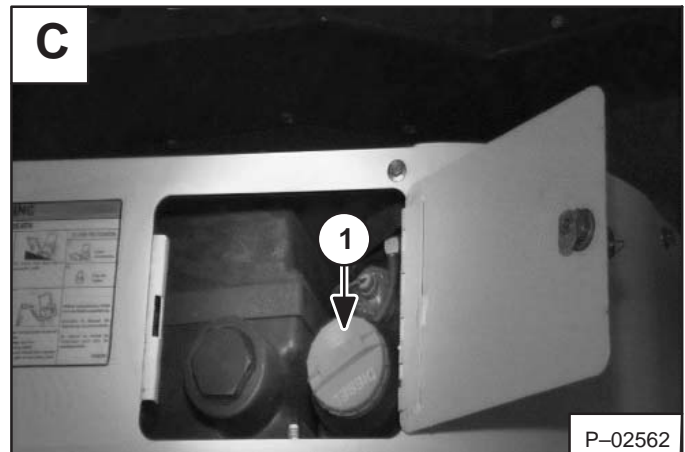
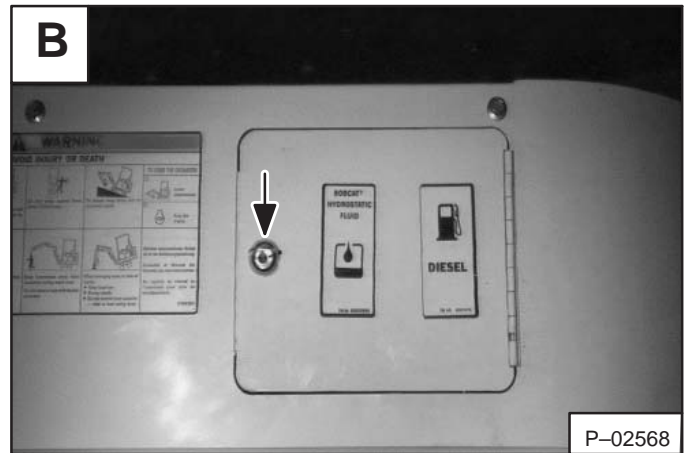
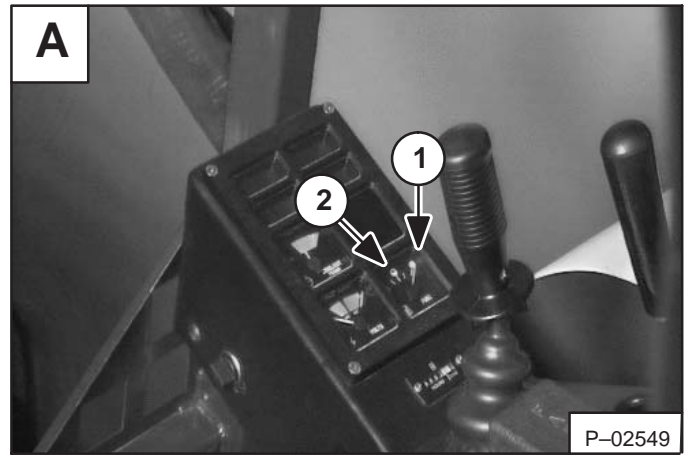

## FUEL SYSTEM (Cont'd)

To remove the water and sediment from the fuel tank, turn the upperstructure until the fuel tank is centered between the rear tracks.

Open the drain valve (Item 1) **[A]** at the bottom of the fuel tank.

Drain all water and sediment into a container.

## Fuel Filter

### Maintenance

See *SERVICE SCHEDULE* Page 1-1 for the correct service interval.

To remove water from the fuel filter element, open the drain valve (Item 1) **[B]** at the bottom of the fuel filter.

Drain the water into a container. When fuel, free of water emerges from the drain valve, close the drain valve.

## Removal And Installation

See the *SERVICE SCHEDULE* Page 1-1 for correct service interval for fuel filter element replacement.

Remove the hose (Item 1) **[C]** from the filter housing and plug the hose, or firmly squeeze the hose to eliminate the fuel from siphoning out of the tank when the element is removed.

Remove the fuel filter element (Item 2) **[C]**. Clean the area around the filter housing. Put oil on the seal of the new filter element. Install the new fuel filter element, and hand tighten only.

## Removing Air From The Fuel System

Loosen the bleed screw (Item 3) **[C]** on the filter housing.

Let the fuel gravity feed from the fuel tank until it emerges from the vent, free of air bubbles.

Close the bleed screw.

The fuel system has an electric fuel pump **[D]**.

Turn the key switch to the ON position (do not start the engine). Leave the key in the ON position for a short period, or until all the air is removed from the fuel system.

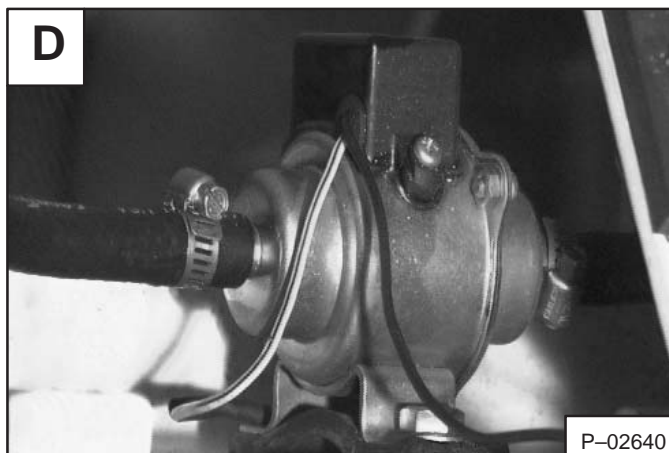
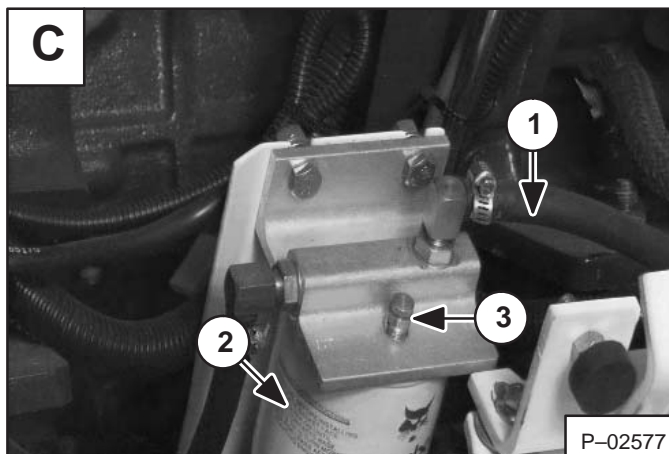
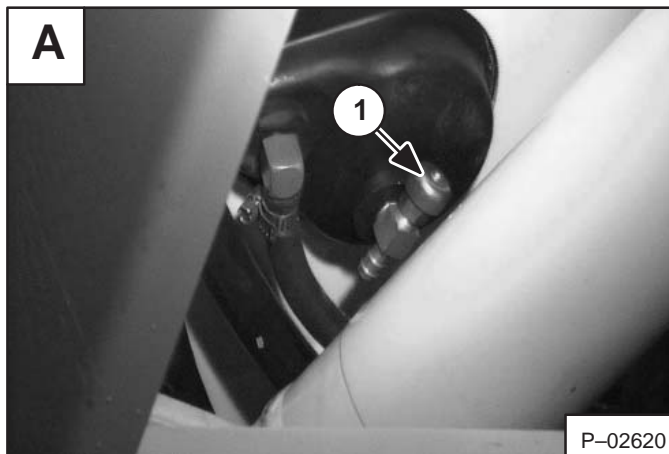

## ENGINE LUBRICATION SYSTEM

### Checking The Engine Oil

Check the engine oil every day.

Stop the engine. Open the engine cover.

Remove the dipstick **[A]**.

Keep the oil level between the marks on the dipstick.

Use a good quality motor oil that meets API Service Classification of CE (See *Fuel, Coolant and Lubrications Chart*, See Page 8–8).

### Engine Oil And Filter Replacement

See the *SERVICE SCHEDULE* Page 1–1 for correct service interval.

Use the following procedure to change the oil and filter:

1. Run the engine until it is at operating temperature.
2. Turn the upperstructure so the engine oil can drain between the tracks. Stop the engine.
3. Remove the drain plug (Item 1) **[B]**. Drain the oil into a container.
4. Remove the oil filter (Item 1) **[C]**, using a filter wrench.
5. Clean the filter housing surface. Put clean oil on the filter gasket. Install the new filter and hand tighten only.
6. Install and tighten the oil drain plug.
7. Remove the oil fill cap **[D]**. Put in 6.3 qts. (6,0 L.) of oil into the engine (See *Fuel, Coolant and Lubricants Chart* Page 8–8).
8. Start the engine and let it run for several minutes. Stop the engine. Check for leaks at the oil filter and drain plug.
9. Check the oil level and add oil as needed to bring it to the *top* mark on the dipstick.

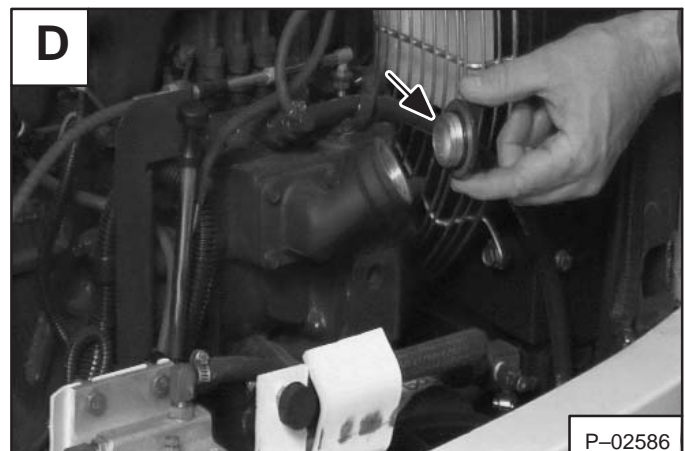
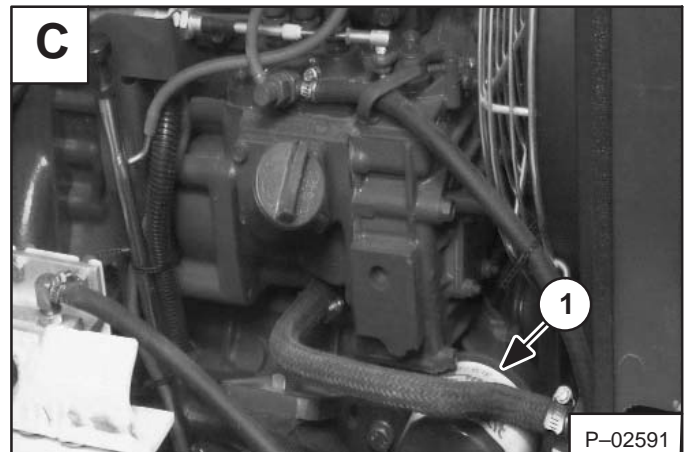
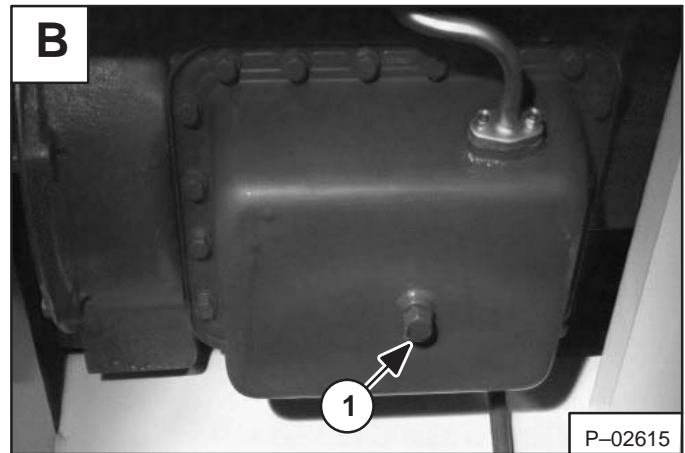

## COOLING SYSTEM

### Coolant Level

When the engine is cool, the coolant level in the recovery tank (Item 1) [A] must be half full.

If the coolant level is low, add pre-mixed coolant (50% water and 50% ethylene glycol) to the recovery tank.

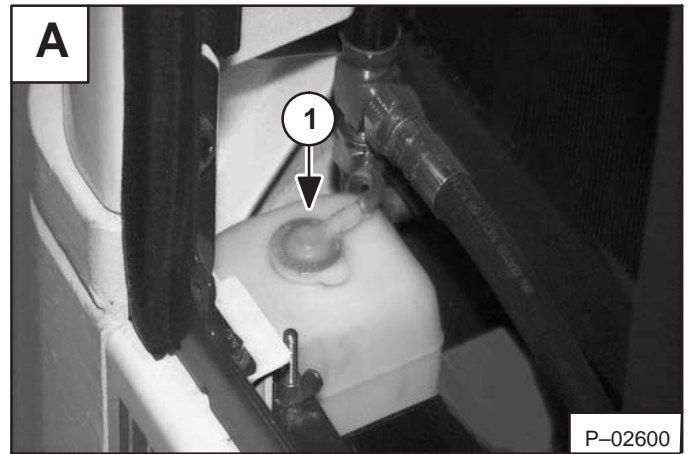

### Coolant Replacement

## WARNING

Do not remove radiator cap when the engine is hot. You can be seriously burned.

W-2070-1285

1. Turn the upperstructure so there is access to the engine and radiator from underneath. Stop the engine.
2. Loosen and remove the radiator cap [B].
3. Open the radiator drain valve (Item 1) [C] at the bottom of the radiator .
4. Drain all coolant from the system.

**NOTE:** Also remove all coolant from the recovery tank (Item 1) [A].

5. When all coolant is removed, close the drain valve.
6. Pre-mix 50% water and 50% ethylene glycol in a separate container. Fill the radiator with the pre-mixed coolant until it is full. Add coolant to the recovery tank until it is half full.
7. Run the engine at idle speed for about 5–10 minutes to remove the air from the cooling system (leave the radiator cap off during this operation).
8. Stop the engine. Check the coolant level and add as needed to bring it up to the radiator filler neck. Install the radiator cap and tighten.

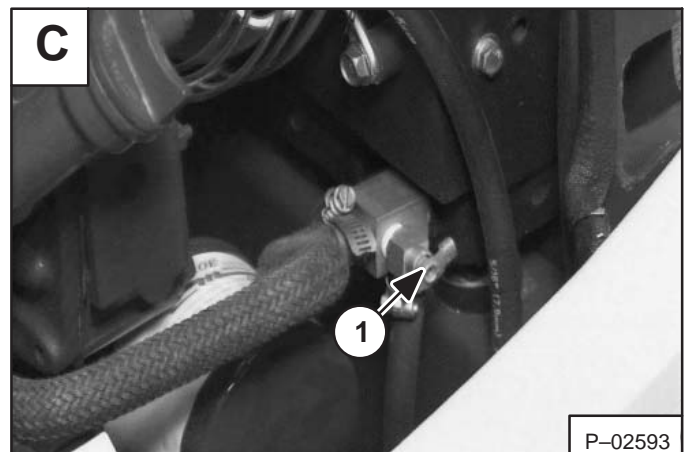

## HYDRAULIC SYSTEM

### Checking And Adding Fluid

To check and add hydraulic fluid to the reservoir, use the following procedure:

1. Put the machine on a flat level surface.
2. Retract the arm and bucket cylinders, put the bucket on the ground and raise the blade. Stop the engine.
3. Check the hydraulic fluid level. It must be visible in the sight gauge (Item 1) [A] located on the side of the hydraulic reservoir.
4. If the fluid level is not correct, open the hydraulic tank access door [B].
5. Remove the oil fill cap (Item 1) [B].

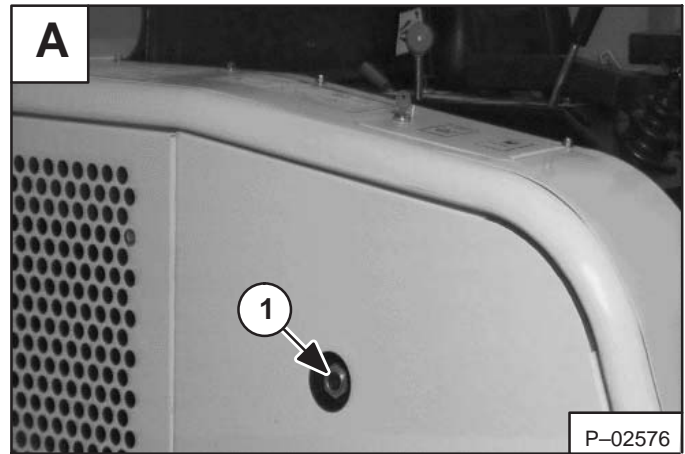

6. Check the condition of the fill strainer [C].

**NOTE: The strainer must be installed when adding hydraulic fluid.**

7. Add the correct fluid to the reservoir until it is in the sight gauge (See *Fuel, Coolant and Lubricants Chart* Page 8–8).
8. Install the reservoir cap and close and lock the access door.

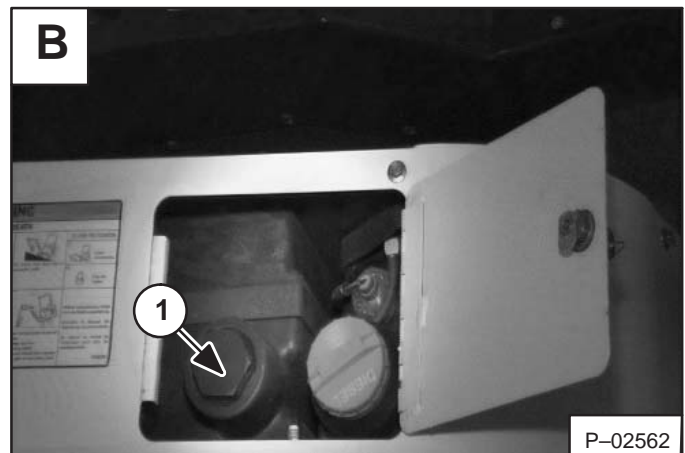

### Replacement Of The Hydraulic Filter

See the *SERVICE SCHEDULE* Page 1–1 for the correct service interval.

1. Open the engine cover.
2. Use a filter wrench and remove the filter element (Item 1) [D].
3. Clean the housing where the filter gasket makes contact.
4. Put clean hydraulic fluid on the gasket. Install the new filter element and hand tighten only.
5. Start the engine. Run the machine through the hydraulic functions. Stop the engine. Check the fluid level at the reservoir and add as needed. Check around the filter for leaks.

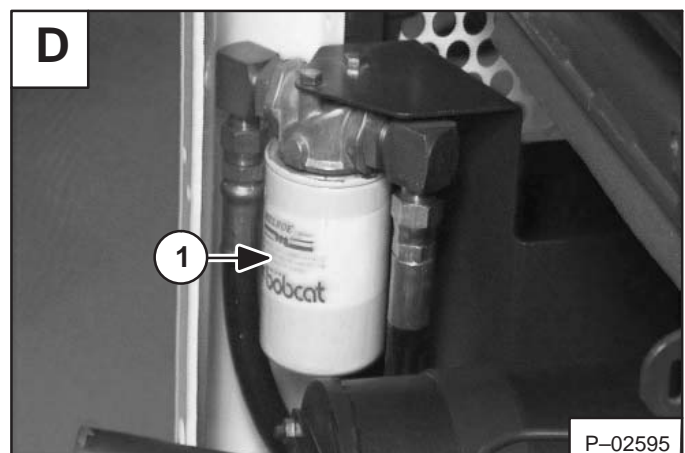

## HYDRAULIC SYSTEM (Cont'd)

### Hydraulic Reservoir

See the *SERVICE SCHEDULE* Page 1-1 for the correct service interval.

1. Move the upperstructure so there is clearance for the reservoir at the track frame.
2. Retract the arm and bucket cylinders, lower the bucket to the ground. Stop the engine.
3. Remove the hydraulic filter. (See Page 1-8.)
4. Remove the drain plug (Item 1) [A] from the bottom of the reservoir.
5. Drain the fluid into a container.
6. Install the drain plug.
7. Add approximately 9.5 gals. (36 L) of fluid to the reservoir. (See *Fuel, Coolant and Lubricants Chart* Page 8-8.)
8. Run the machine through the hydraulic functions. Check the fluid level and add as needed.

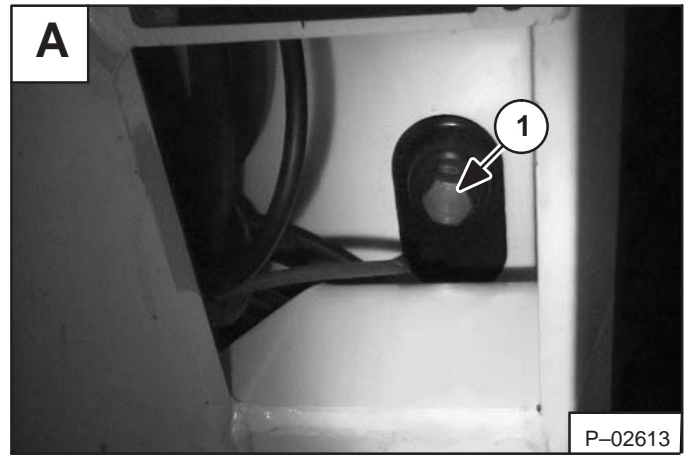

## WARNING

Always clean up spilled fuel or oil. Keep heat, flames, sparks or lighted tobacco away from fuel and oil. Failure to use care around combustibles can cause explosion or fire which can result in injury or death.

W-2103-1285

## USING A BOOSTER BATTERY (Jump Starting)

### Procedure

If it is necessary to use a booster battery to start the engine. **BE CAREFUL!**

Make sure the swing locking lever is in the engaged position.

The key switch must be in the "OFF" position.

The booster battery must be 12 volt.

Remove the three bolts (Item 1) [A] and remove the right side cover.

Connect the end of the first cable to the positive (+) terminal of the booster battery. Connect the other end of the same cable to the positive (+) terminal (Item 1) [B] of the machine battery.

Connect the end of the second cable to the negative (-) terminal (Item 2) [B] of the booster battery. Connect the other end of the same cable to the frame (Item 2) [B].

**NOTE: Also see *Cold Temperature Starting Condition, Operation & Maintenance Manual.***

Start the engine. After the engine is running, remove the cable (Item 2) [B] connected to the frame first. Disconnect the cable from the machine battery (Item 1) [B].

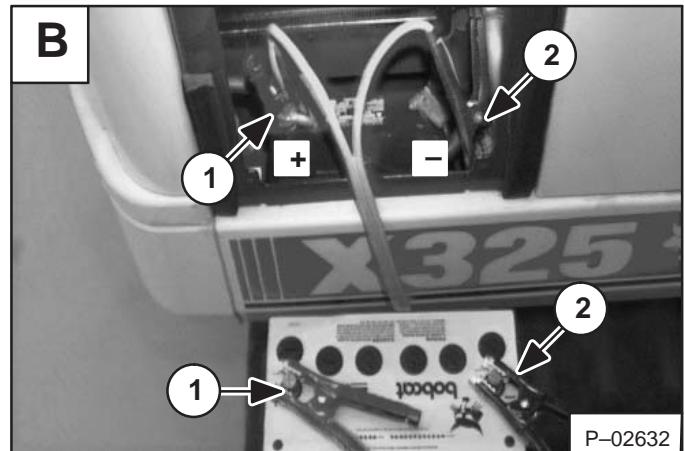
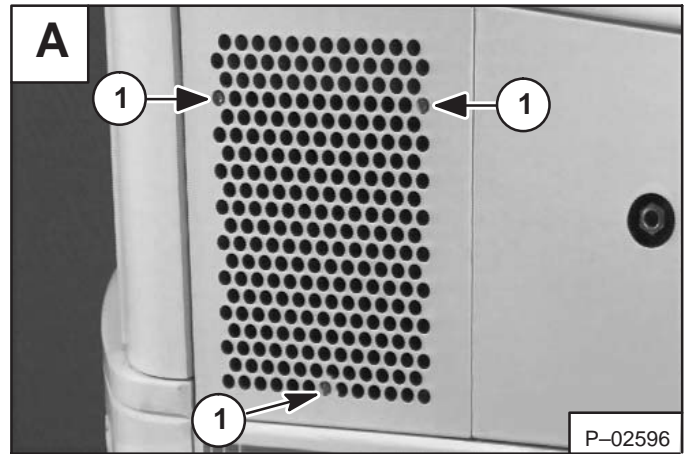

## IMPORTANT

Damage to the alternator can occur if:

- Engine is operated with battery cables disconnected.
- Battery cables are connected when using a fast charger or when welding on the loader (Remove both cables from the battery).
- Extra battery cables (booster cables) are connected wrong from the battery.

I-2023-1285

## IMPORTANT

If jump starting the excavator from a second machine:

When jump starting the excavator from a battery installed in a second machine. Make sure that the second machine is **NOT** running while using the glow plugs. High voltage spikes from a running machine can burn out the glow plugs.

I-2060-0195



## WARNING

Keep arcs, sparks, flames and lighted tobacco away from batteries. When *jumping* from booster battery make final connection (negative) at engine frame.

Do not jump start or charge a frozen or damaged battery. Warm battery to 60°F. (16°C.) before connecting to a charger. Unplug charger before connecting or disconnecting cables to battery. Never lean over battery while boosting, testing or charging.

Battery gas can explode and cause serious injury.

W-2066-1296

## LUBRICATION OF THE HYDRAULIC EXCAVATOR

### Procedure

Lubricate the Hydraulic Excavator as specified in the *SERVICE SCHEDULE* Page 1-1 for the best performance of the machine.

Always use a good quality lithium based multipurpose grease when lubricating the machine. Apply the lubricant until extra grease shows. 

Ref.	Description (# of Fittings)
------	-----------------------------

- |     |  |
|-----|--|
| 1.  | Blade Cylinder Rod End, every 8–10 hrs. (1) [A].   |
| 2.  | Blade Pivots, every 8–10 hrs. (2) [A].   |
| 3.  | Blade Cylinder Base End, every 8–10 hrs. (1) [A]   |
| 4.  | Boom Swing Bracket Pivot, every 8–10 hrs. (2) [B].   |
| 5.  | Boom Base Pivot, every 8–10 hrs. (1) [B].  |
| 6.  | Boom Cylinder Base End, Every 8–10 hrs. (1) [C].   |
| 7.  | Boom Swing Cylinder Rod End, Every 8–10 hrs. (1) [C].  |
| 8.  | Swing Circle Pinion, ever 50 hrs. (1) [C]. Install four pumps of grease from a grease gun into the grease fitting. Rotate the upperstructure 180° and install four more pumps of grease into the grease fitting. |
| 9.  | Boom Cylinder Rod End, every 8–10 hrs. (1) [D].  |
| 10. | Arm Cylinder Base end, every 8–10 hrs. (1) [D].  |

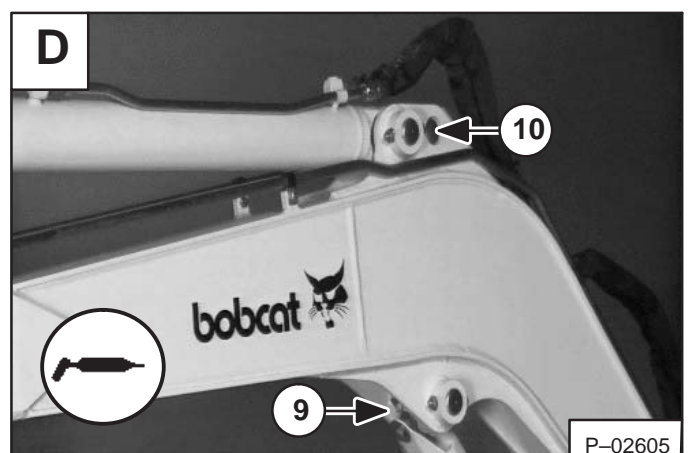
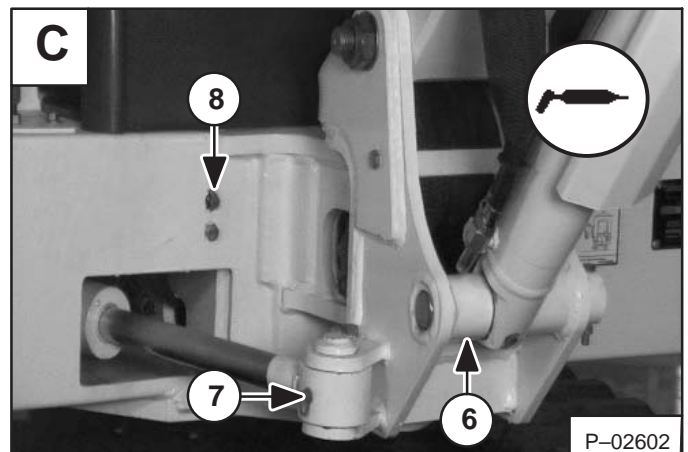
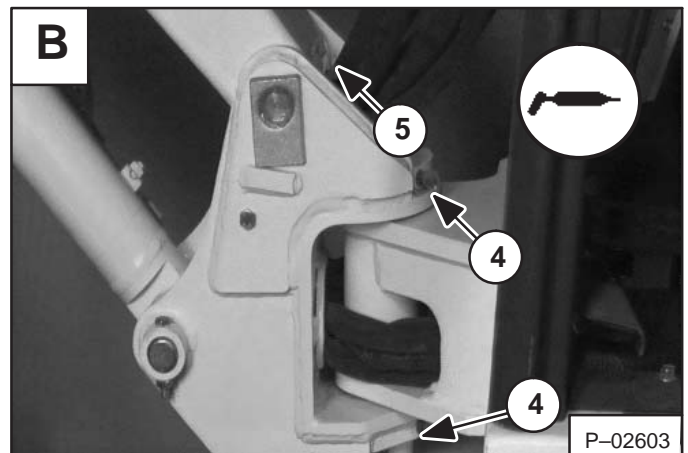
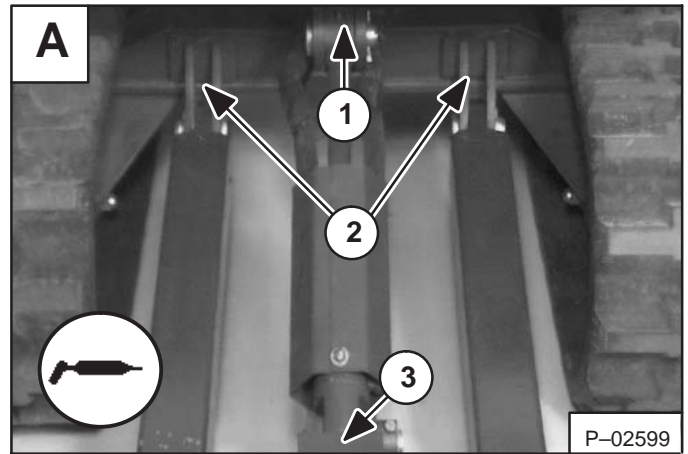

## LUBRICATION OF THE EXCAVATOR (Cont'd)

Ref. Description (# of Fittings) 

- 11. Arm Cylinder Rod End, every 8–10 hrs. (1) [A].
- 12. Arm Base Pivot, every 8–10 hrs. (1) [A].
- 13. Bucket Cylinder Base End, every 8–10 hrs. (1) [A].

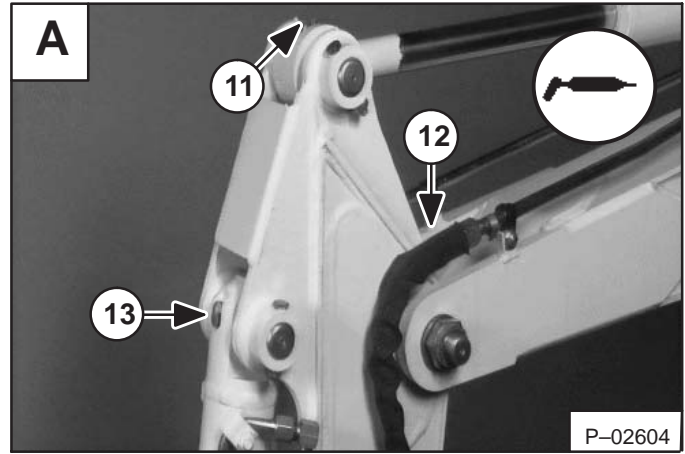

- 14. Bucket Cylinder Rod End, every 8–10 hrs. (1) [B].
- 15. Bucket Link Pivots, every 8–10 hrs. (2) [B].
- 16. Bucket Pivots, every 8–10 hrs. (3) [B].

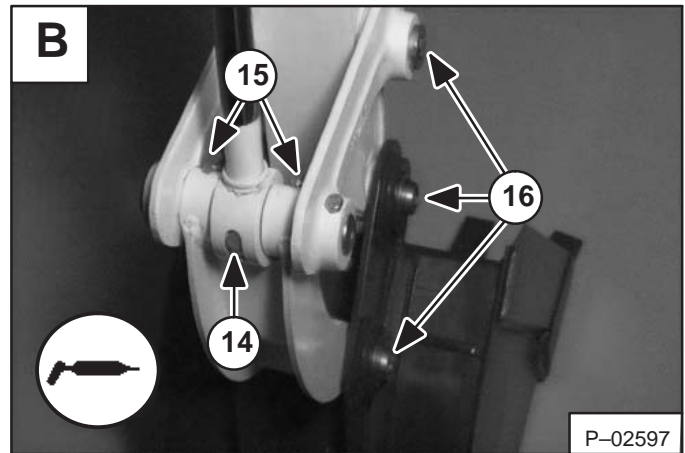

- 17. Swing Circle Ball Bearings, every 50 hrs.(2) [C].

**NOTE:** Do not over grease the swing circle or damage to the seals could result. Install four to five pumps of grease from a grease gun into each of the two grease fittings. Rotate the upperstructure 90° and install four to five pumps of grease into each of the two grease fittings.

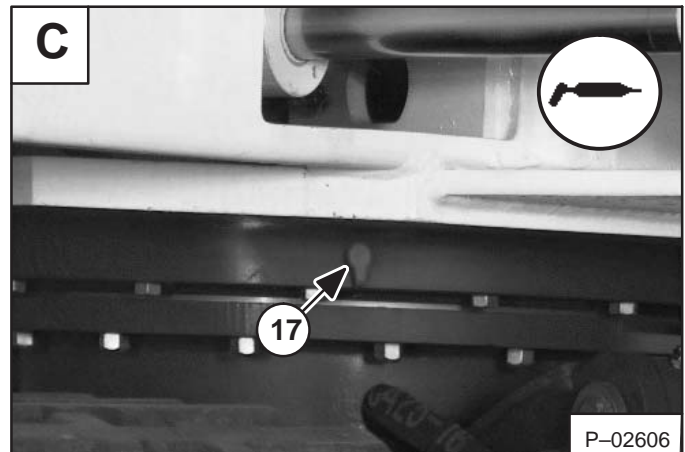

- 18. Boom Swing Cylinder Base End, every 8–10 hrs. (1) [D]. (The grease fittings located under the right side of the upperstructure)

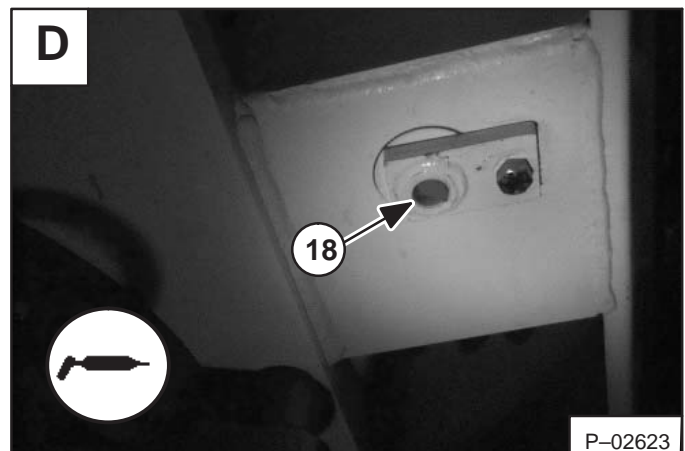

## FINAL DRIVE CASE

### Checking Oil Level

1. Put the machine on a flat level surface with the plugs positioned as shown in figure [A].
2. Remove the top plug (Item 1) [A]. The oil level should be at the bottom edge of the plug hole.
3. Add 90W lube through the hole if the oil level is below the hole. (See *Fuel, Coolant And Lubricant Chart* Page 8–8.)
4. Install and tighten the plug.
5. Repeat the procedure for the other side.

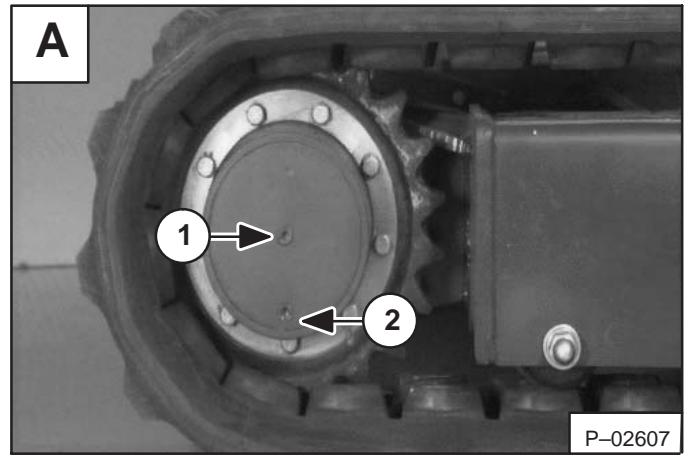

### Draining Final Drive Case

1. Put the machine on a flat level surface with the plugs positioned as shown in figure [A].
2. Remove the bottom plug (Item 2) [A] and top plug (Item 1) [A].
3. After all the oil is removed, install and tighten the bottom plug (Item 2) [A].
4. Add .55 quarts (0,5L) of 90W Lube to the top plug hole or until the oil level is at the bottom edge of the plug hole. Install the plug.
5. Repeat the procedure for the other side.

## HYDRAULIC SERVICE INFORMATION

# IMPORTANT

When repairing hydrostatic and hydraulic systems, clean the work area before disassembly and keep all parts clean. Always use caps and plugs on hoses, tubelines and ports to keep dirt out. Dirt can quickly damage the system.

I-2003-0888

### Checking The Main Relief Valve

The hydraulic system has three main relief valves protecting the hydraulic pump from high pressure.

The hydraulic pump has three diagnostic couplers (Item 1) [A] for checking each pump sections pressure.

The following tools will be needed for the Diagnostic Coupler Check:

MEL1355 – Test Kit  
MEL1355-3 – 5000 PSI Gauge  
MEL1355-12 – Coupler  
MEL1355-4 – Hose

Connect the coupler and gauge from the test kit to the hose.

Stop the engine.

Connect the coupler to the diagnostic coupler on the pump section being tested.

Start the engine and run at full RPM. Warm the hydraulic fluid to 140° F. (60° C.).

Stroke a cylinder to it's limit, to open the relief valve.

PUMP 1: Extend the bucket cylinder.  
PUMP 2: Extend the arm cylinder.  
PUMP 3: Retract the blade cylinder.

**NOTE: Pump section 1 is the closest to the engine.**

The system relief valve pressure for each pump section recorded at the pump, should be as follows [A]:

PUMP 1: 2350 – 2400 PSI (16207 – 16551 kPa)  
PUMP 2: 2350 – 2400 PSI (16207 – 16551 kPa)  
PUMP 3: 2350 – 2400 PSI (16207 – 16551 kPa)

Stop the engine.

Move the coupler to the next pump section being tested.

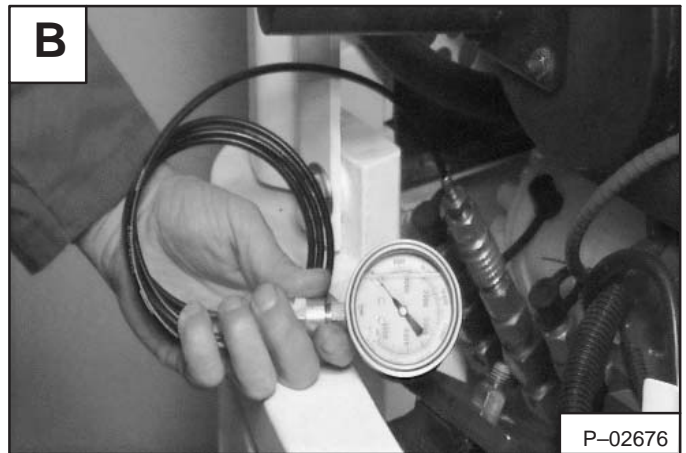
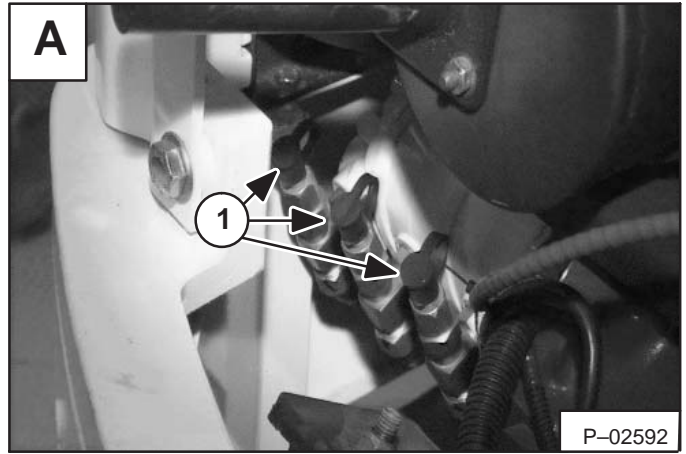

## HYDRAULIC SERVICE INFORMATION (Cont'd)

### Checking The Hydraulic Pump

The hydraulic pump flow for a new pump (S/N 51182001–511820408) should be 7.1 GPM (27 L/min) at 2500 RPM. The hydraulic pump flow for a new pump (S/N 511820409 & Above) should be 6.97 GPM (26,4 LPM) at 2500 RPM.

The following tool will be needed for the hydraulic pump test:

MEL10003 – Hydraulic Tester

Stop the engine.

Raise the engine cover [A].

Remove the outlet hose from the hydraulic pump section being tested [B].

Connect the hose removed from the pump to the outlet of the hydraulic tester [B].

Connect the inlet hose of the tester to the fitting on the pump [B].

**NOTE: The tester connections will be the same for each pump section.**

**NOTE: Open the flow control knob (Item 1) [C] fully to prevent pump damage.**

Start the engine and run at low RPM. Make sure the tester is connected correctly. If no flow is indicated at the tester, the hoses are connected wrong.

Increase the engine speed to full RPM. Warm the hydraulic fluid to 140°F (60°C) by turning the restrictor valve until the gauge reads about 1000 PSI (6895 kPa). Do not exceed system pressure.

After the temperature is correct, open the restrictor valve fully.

Record the pump free flow GPM (L/min).

Close the flow control knob (Item 1) [C] slowly to 100 PSI below the relief valve setting (2350–2400 PSI 17207–16897 kPa).

Record the pump high pressure flow GPM (L/min).

**NOTE: The high pressure flow must be at least 80% of free flow.**

$$\% = \frac{\text{HIGH PRESSURE FLOW (GPM)}}{\text{FREE FLOW (GPM)}} \times 100$$

If the high pressure flow is less than 80% of free flow, remove the hydraulic pump for repair or replacement.

Repeat the testing procedure for each pump section.

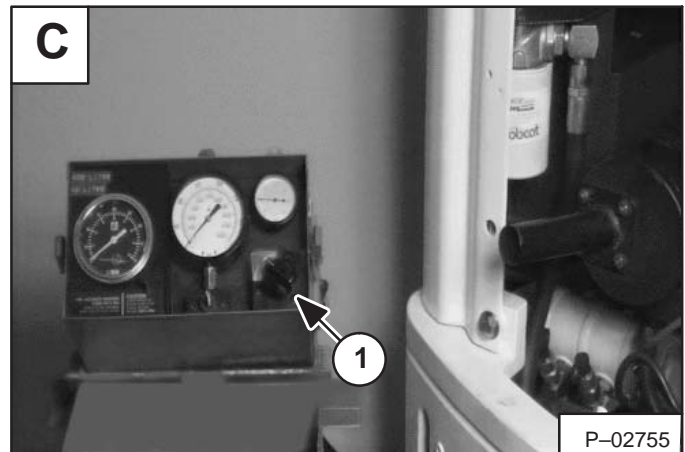
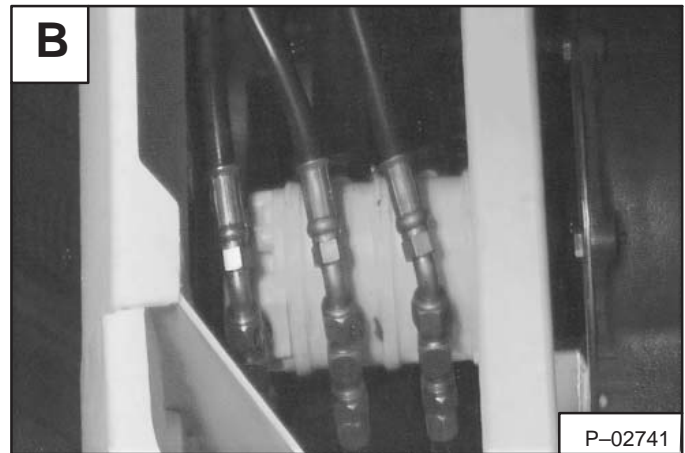

## HYDRAULIC PUMP (Cont'd)

### Removal And Installation

# IMPORTANT

When repairing hydrostatic and hydraulic systems, clean the work area before disassembly and keep all parts clean. Always use caps and plugs on hoses, tubelines and ports to keep dirt out. Dirt can quickly damage the system.

I-2003-0888

**NOTE:** Pump removal for S/N 511820001–511820408 is shown. The procedure is the same for S/N 511820409 & Above.

Turn the upperstructure so there is access to the pump between the tracks.

Remove the left hand corner post. (See Page 4–5.)

Remove the left side cover. (See Page 4–4.)

Remove the tool box. (See Page 4–4.)

**NOTE:** Mark the hoses and tubelines for correct installation.

Disconnect the inlet hoses (Item 1) [A] from the hydraulic pump.

Drain the hydraulic fluid into a container (approximately 9.5 gal. / 36 L)

Disconnect the pressure hoses [A].

Loosen the pump mounting bolts (Item 1) [B].

Remove the bolts.

**Installation:** Tighten the bolts to 48–55 ft. lbs. (65–75 Nm) torque.

### Parts Identification (S/N 51182001–511820408)

#### Triple Gear Pump [C]

1. Plate
2. O-ring
3. Gears
4. Body
5. Seal
6. Gasket
7. Washer

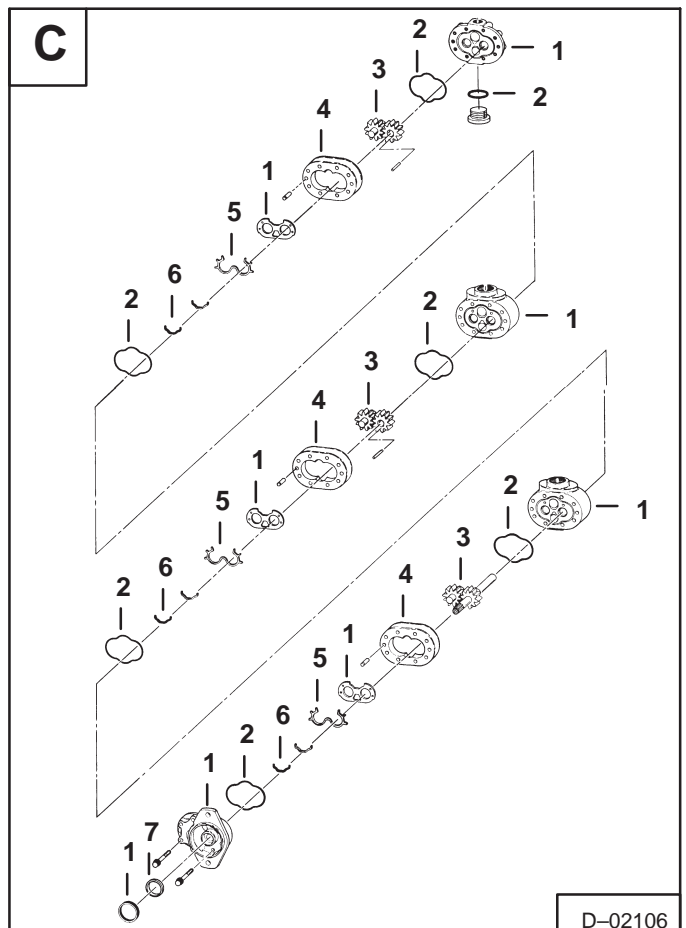
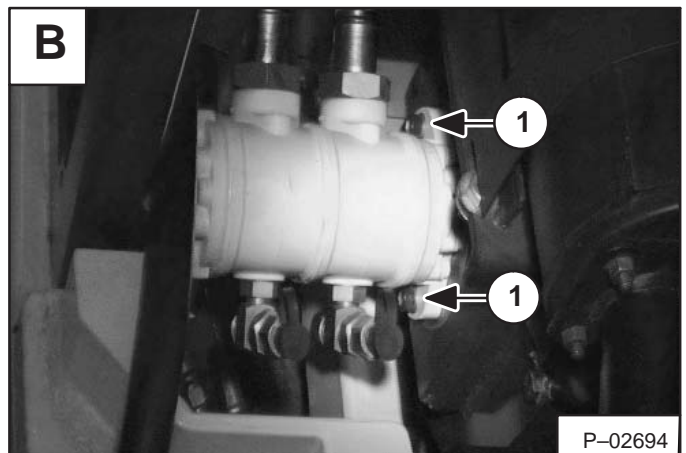
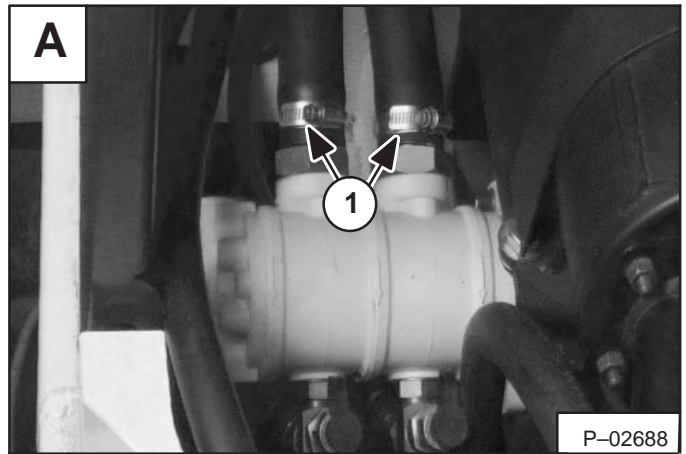

## HYDRAULIC PUMP (Cont'd)

Disassembly And Assembly (S/N 511820001-511820408)

# IMPORTANT

When repairing hydrostatic and hydraulic systems, clean the work area before disassembly and keep all parts clean. Always use caps and plugs on hoses, tubelines and ports to keep dirt out. Dirt can quickly damage the system.

I-2003-0888

Clean the external pump surfaces. Mark the pump sections for ease of assembly [A].

Clamp the pump in a vise with protective jaws [A].

**NOTE: Do Not over tighten the vise or pump distortion may occur.**

Loosen the eight bolt from the front pump cover [A].

**Installation:** Tighten the bolt to 25–28 ft. lbs. (34–38 Nm) torque.

Remove the pump from the vise.

Remove the eight bolts and remove the front pump cover [B].

Remove the pump end cover (Item 1) [C], pump body (Item 2) [C], drive gear (Item 3) [C], idler gear (Item 4) [C], wear plate (Item 5) [C], and the dowel key (Item 6) [C].

**NOTE: The dowel key (Item 6) [C] must be removed from the shaft so that the shaft can be removed from the next pump section.**

Remove the adapter plate (Item 1) [D], pump body (Item 2) [D], drive gear (Item 3) [D], idler gear (Item 4) [D], wear plate (Item 5) [D], and the dowel key (Item 6) [D].

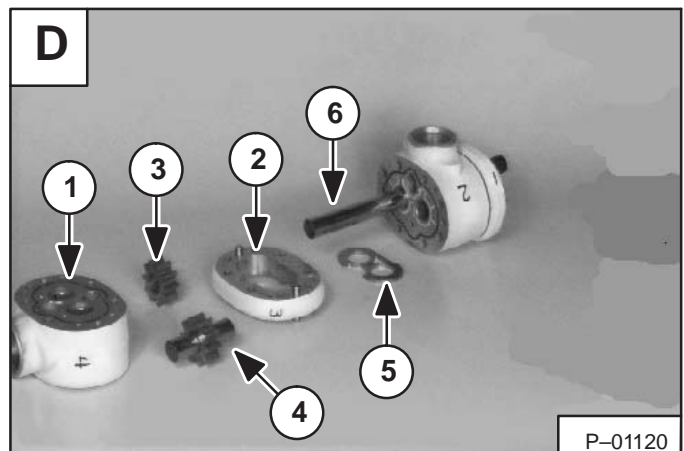
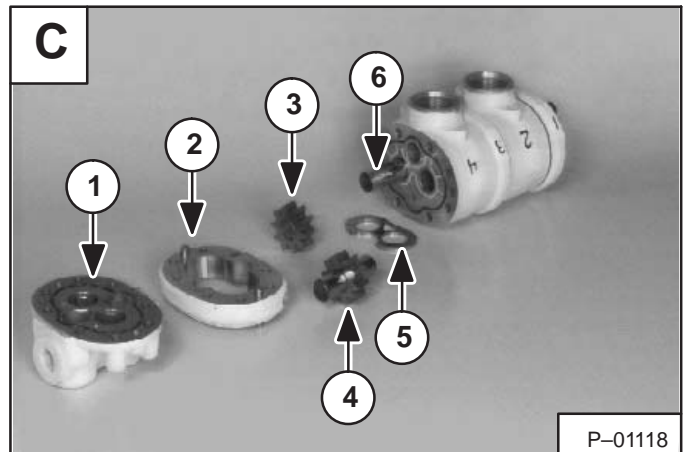
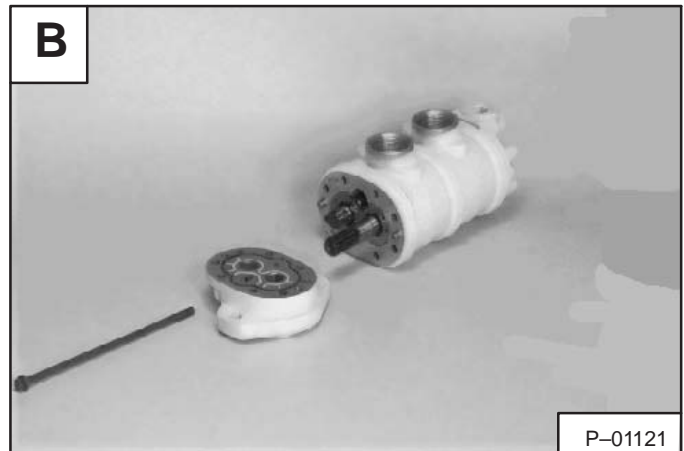
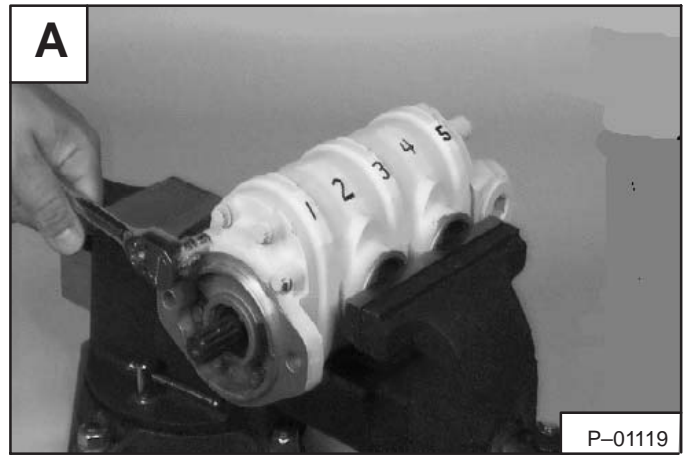



**Suggest:**

**If the above button click is invalid.**

**Please download this document**

**first, and then click the above link**

**to download the complete manual.**

**Thank you so much for reading**

## HYDRAULIC PUMP (Cont'd)

### Disassembly And Assembly (S/N 511820001–511820408) (Cont'd)

Remove adapter plate (Item 1) [A], pump body (Item 2) [A], drive gear and shaft assembly (Item 3) [A], idler gear (Item 4) [A], and wear plate (Item 5) [A].

**NOTE:** The drive gear can be removed from the drive shaft (Item 3) [A] but these parts are not serviceable separately and must be replaced as an assembly if damaged.

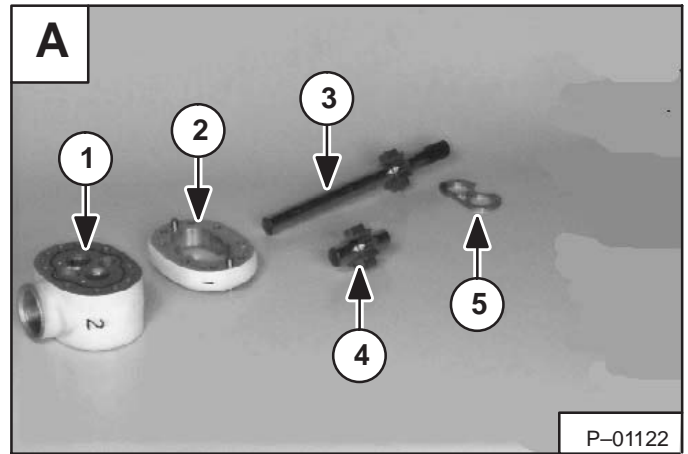

Remove the O-ring from the two center adapter plates and the front cover [B].

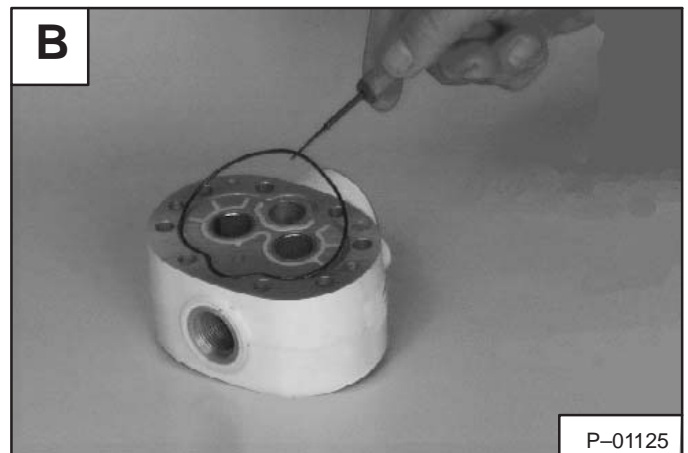

Remove the gasket (Item 1) [C] and the molded O-ring (Item 2) [C] from the two center adapter plates and the front cover.

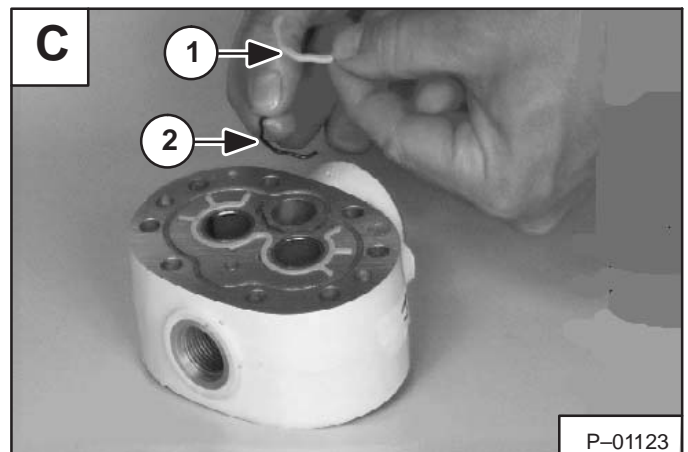

Remove the gasket from the two center adapter plates and the front cover [D].

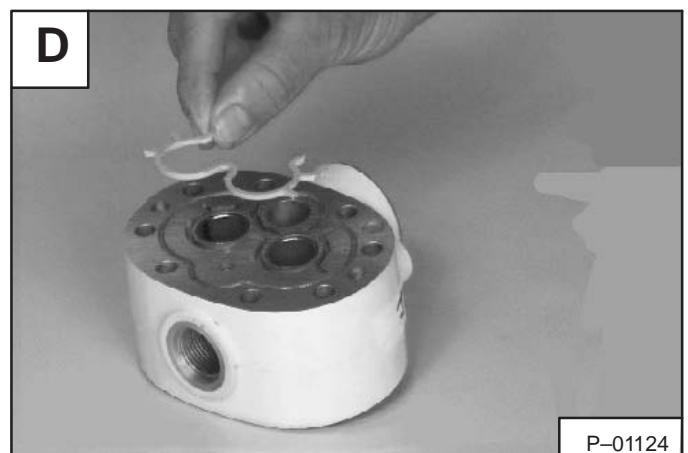

**<https://www.ebooklibonline.com>**

Hello dear friend!

Thank you very much for reading.

Enter the link into your browser.

The full manual is available for immediate download.

**<https://www.ebooklibonline.com>**