

X 56, 76

Excavator

Service Manual

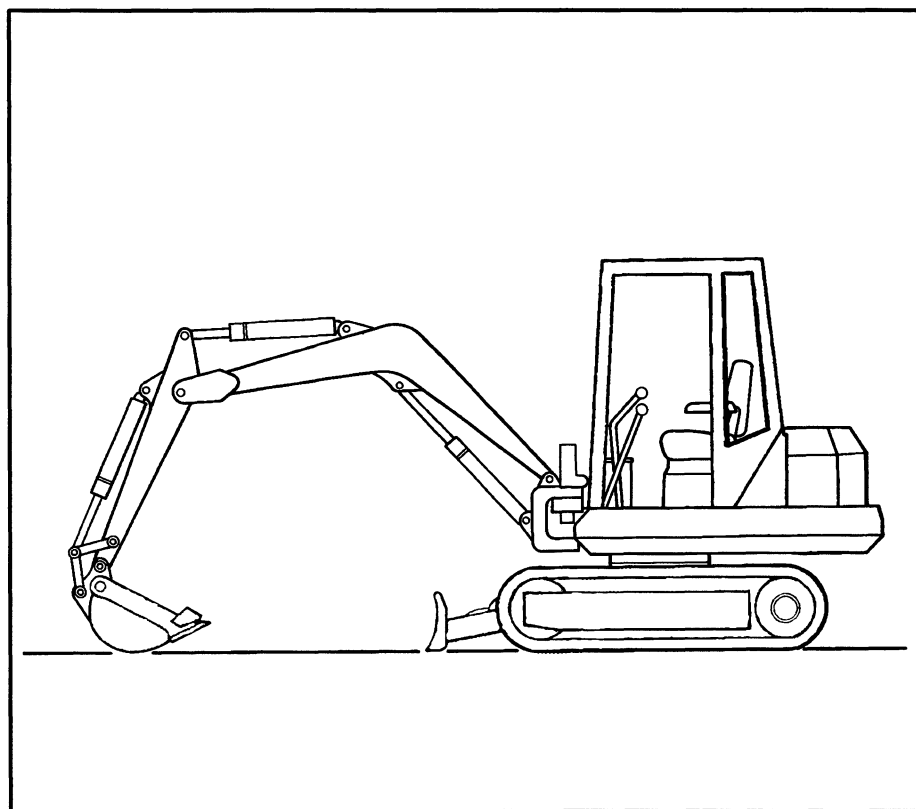

MELROE
INGERSOLL-RAND

6570475 (5-88)

Printed in U.S.A.



© Melroe Company 1996

CONTENTS

	No. of Page
10 ENGINE	
11 STRUCTURE AND FUNCTION.....	11-1
13 DISASSEMBLY AND ASSEMBLY.....	13-1
20 POWER TRAIN	
21 STRUCTURE AND FUNCTION.....	21-1
23 DISASSEMBLY AND ASSEMBLY.....	23-1
24 MAINTENANCE STANDARD.....	24-1
30 UNDERCARRIAGE	
31 STRUCTURE AND FUNCTION.....	31-1
34 MAINTENANCE STANDARD.....	34-1
60 HYDRAULIC SYSTEM	
61 STRUCTURE AND FUNCTION.....	61-1
62 TESTING AND ADJUSTING.....	62-1
63 DISASSEMBLY AND ASSEMBLY.....	63-1
64 MAINTENANCE STANDARD.....	64-1
70 WORK EQUIPMENT	
71 STRUCTURE AND FUNCTION.....	71-1
74 MAINTENANCE STANDARD.....	74-1
80 ELECTRICAL SYSTEM	
81 STRUCTURE AND FUNCTION.....	81-1



IMPORTANT SAFETY NOTICE

Proper service and repair is extremely important for the safe operation of your machine. The service and repair techniques recommended and described in this manual are both effective and safe methods of operation. Some of these operations require the use of tools specially designed for the purpose.

To prevent injury to workers, the symbol  is used to mark safety precautions in this manual. The cautions accompanying these symbols should always be followed carefully. If any dangerous situation arises or could possibly arise, first consider safety, and take the necessary actions to deal with the situation.



SAFETY

GENERAL PRECAUTIONS

Mistakes in operation are extremely dangerous. Read the Operation and Maintenance Manual carefully BEFORE operating the machine.

1. Before carrying out any greasing or repairs, read all the precautions given on the decals which are on the machine.
2. When carrying out any operation, always wear safety shoes and helmet. Do not wear loose work clothes, or clothes with buttons missing.

Always wear safety glasses when using tools.
3. If welding repairs are needed, always have a trained, experienced welder carry out the work. When welding always wear welding gloves, apron, glasses, cap and other clothes suited for welding work.
4. When doing any operation with two or more workers, always agree on the operating procedure before starting. Always inform your fellow workers before starting any step of the operation. Before starting work hang UNDER REPAIR signs on the controls in the operator's compartment.
5. Keep all tools in good condition and learn the correct way to use them.
6. Determine a place in the workshop to keep tools and removed parts. Always keep the tools and parts in their correct places. Always keep the work area clean and make sure that there is no dirt or oil on the floor. Smoke only in the areas provided for smoking. Never smoke while working.

PREPARATIONS FOR WORK

7. Before adding oil or making any repairs, park the machine on hard, level ground, and block the wheels or tracks to prevent the machine from moving.
8. Before starting work, lower blade, ripper, bucket or any other work equipment to the ground. If this is not possible, insert the safety pin or use blocks to prevent the work equipment from falling. In addition, be sure to lock all the control levers and hang warning signs on them.
9. When disassembling or assembling, support the machine with blocks, jacks or stands before starting work.
10. Remove all mud and oil from the steps or other places used to get on or off the machine. Always use the handrails or steps when getting on or off the machine. Never jump on or off the machine. If it is impossible to use the handrails or steps, use a stand to provide safe footing.

PRECAUTIONS DURING WORK

11. When removing the oil filler cap, drain plug or hydraulic pressure measuring plugs, loosen them slowly to prevent oil from spurting out. Before disconnecting or removing components of the oil, water or air circuits, first remove all pressure from the circuit.
12. The water and oil in the circuits are hot when the engine is stopped, so be careful not to get burned.
Wait for the oil and water to cool before carrying out any work on the oil or water circuits.
13. Before starting work, remove the leads from the battery. Always remove the lead from the negative (–) terminal first.
14. When raising heavy components, use a hoist or crane.
Check that wire rope, chains and hooks are free from damage.
Always use lifting equipment which has ample capacity.
Install the lifting equipment at the correct places. Use a hoist or crane and operate slowly to prevent the component from hitting any other part. Do not work with any part still raised by the hoist or crane.
15. When removing covers which are under internal pressure or under pressure from a spring, always leave two bolts in position on opposite sides. Slowly release the pressure, then slowly loosen the bolts to remove.
16. When removing components, be careful not to break or damage the wiring. Damaged wiring may cause electrical fires.
17. When removing piping, stop the fuel or oil from spilling out. If any fuel or oil drips on to the floor, wipe it up immediately. Fuel or oil on the floor can cause you to slip, or can start fires.
18. As a general rule, do not use gasoline to wash parts.
19. Be sure to assemble all parts again in their original places.
Replace any damaged parts with new parts.
 - When installing hoses and wires, be sure that they will not be damaged by contact with other parts when the machine is being operated.
20. When installing high pressure hoses, make sure that they are not twisted. Damaged tubes are dangerous, so be extremely careful when installing tubes for high pressure circuits. Also, check that connecting parts are correctly installed.
21. When assembling parts, always use the specified tightening torques. When installing protective parts such as guards, or parts which vibrate violently or rotate at high speed, be particularly careful to check that they are installed correctly.
22. When aligning two holes, never insert your fingers or hand, your fingers could get caught in a hole.
23. When measuring hydraulic pressure, check that the measuring tool is correctly assembled before taking any measurements.
24. Take care when removing or installing the tracks of track-type machines.
When removing the track, the track separates suddenly, so never let anyone stand at either end of the track.

<https://www.ebooklibonline.com>

Hello dear friend!

Thank you very much for reading.

Enter the link into your browser.

The full manual is available for immediate download.

<https://www.ebooklibonline.com>

FOREWORD

This shop manual has been prepared as an aid to improve the quality of repairs by giving the serviceman an accurate understanding of the product and by showing him the correct way to perform repairs and make judgements. Make sure you understand the contents of this manual and use it fully at every opportunity.

This shop manual contains the necessary technical information for operations performed in a service workshop.

For ease of understanding, the manual is divided into chapters for each main group of components; these chapters are further divided into the following sections.

STRUCTURE AND FUNCTION

This section explains the structure and function of each component. It serves not only to give an understanding of the structure, but also serves as reference material for troubleshooting.

TESTING AND ADJUSTING

This section explains checks to be made before and after performing repairs, as well as adjustments to be made at completion of the checks and repairs.

Troubleshooting charts correlating "Problems" to "Causes" are also included in this section.

DISASSEMBLY AND ASSEMBLY

This section explains the order to be followed when removing, installing, disassembling or assembling each component, as well as precautions to be taken for these operations.

MAINTENANCE STANDARD



This section gives the judgement standards when inspecting disassembled parts.





NOTICE

The specifications contained in this shop manual are subject to change at any time and without any advance notice. Contact your dealer for the latest information.

SYMBOLS

So that the shop manual can be of ample practical use, important places for safety and quality are marked with the following symbols.



Symbol	Item	Remarks
	Safety	Special safety precautions are necessary when performing the work.
	Caution	Special technical precautions or other precautions for preserving standards are necessary when performing the work.
	Weight	Weight of parts or systems. Caution necessary when selecting hoisting wire, or when working posture is important, etc.

	Tightening torque	Places that require special attention for the tightening torque during assembly.
	Coat	Places to be coated with adhesives and lubricants etc.
	Oil, water	Places where oil, water or fuel must be added, and the capacity.
	Drain	Places where oil or water must be drained, and quantity to be drained.

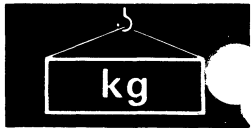
HOISTING INSTRUCTIONS



WARNING

 Heavy parts (25 kg or more) must be lifted with a hoist etc. In the **Disassembly and Assembly** section, every part weighing 25 kg or more is indicated clearly with the symbol 

1. If a part cannot be smoothly removed from the machine by hoisting, the following checks should be made:

- Check for removal of all bolts fastening the part to the relative parts.
- Check for existence of another part causing interference with the part to be removed.

2. Wire ropes

1) Use adequate ropes depending on the weight of parts to be hoisted, referring to the table below:

Wire ropes (Standard "Z" or "S" twist ropes without galvanizing)	
Rope diameter (mm)	Allowable load (tons)
10	1.0
11.2	1.4
12.5	1.6
14	2.2
16	2.8
18	3.6
20	4.4
22.4	5.6
30	10.0
40	18.0
50	28.0
60	40.0

The allowable load value is estimated to be one-sixth or one-seventh of the breaking strength of the rope used.

2) Sling wire ropes from the middle portion of the hook.

Slinging near the edge of the hook may cause the rope to slip off the hook during hoisting, and a serious accident can result. Hooks have maximum strength at the middle portion.

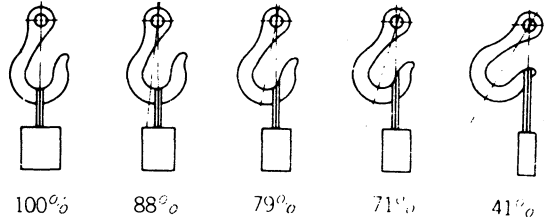

FS0064

3) Do not sling a heavy load with one rope alone, but sling with two or more ropes symmetrically wound on to the load.

WARNING

 Slings with one rope may cause turning of the load during hoisting, untwisting of the rope, or slipping of the rope from its original winding position on the load, which can result in a dangerous accident.

4) Do not sling a heavy load with ropes forming a wide hanging angle from the hook.

When hoisting a load with two or more ropes, the force subjected to each rope will increase with the hanging angles. The table below shows the variation of allowable load (kg) when hoisting is made with two ropes, each of which is allowed to sling up to 1000 kg vertically, at various hanging angles.

When two ropes sling a load vertically, up to 2000 kg of total weight can be suspended. This weight becomes 1000 kg when two ropes make a 120° hanging angle. On the other hand, two ropes are subjected to an excessive force as large as 4000 kg if they sling a 2000 kg load at a lifting angle of 150°.

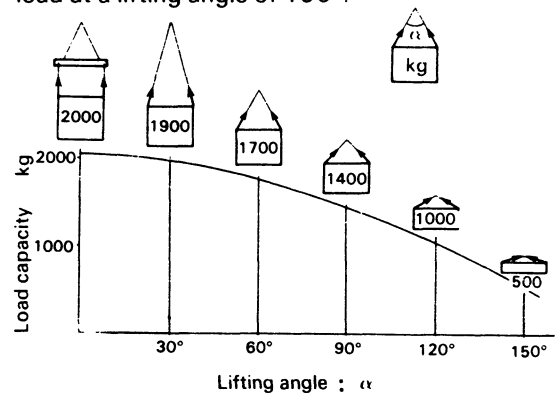



FS0065



STANDARD TIGHTENING TORQUE

1. STANDARD TIGHTENING TORQUE OF BOLTS AND NUTS

The following charts give the standard tightening torques of bolts and nuts. Exceptions are given in sections of "Disassembly and Assembly"

Thread diameter of bolt (mm)	Width across flat (mm)		
		kgm	Nm
6	10	1.35 ± 0.15	13.2 ± 1.4
8	13	3.2 ± 0.3	31.4 ± 2.9
10	17	6.7 ± 0.7	65.7 ± 6.8
12	19	11.5 ± 1.0	112 ± 9.8
14	22	18.0 ± 2.0	177 ± 19
16	24	28.5 ± 3	279 ± 29
18	27	39 ± 4	383 ± 39
20	30	56 ± 6	549 ± 58
22	32	76 ± 8	745 ± 78
24	36	94.5 ± 10	927 ± 98
27	41	135 ± 15	1320 ± 140
30	46	175 ± 20	1720 ± 190
33	50	225 ± 25	2210 ± 240
36	55	280 ± 30	2750 ± 290
39	60	335 ± 35	3280 ± 340

This torque table does not apply to the bolts with which nylon packings or other non-ferrous metal washers are to be used, or which require tightening to otherwise specified torque.

★ Nm (newton meter): 1Nm ≅ 0.1 kgm

2. TIGHTENING TORQUE OF SPLIT FLANGE BOLTS

Use these torques for split flange bolts.

Thread diameter of bolt (mm)	Width across flats (mm)	Tightening torque	
		kgm	Nm
10	14	6.7 ± 0.7	65.7 ± 6.8
12	17	11.5 ± 1	112 ± 9.8
16	22	28.5 ± 3	279 ± 29

STANDARD TIGHTENING TORQUE

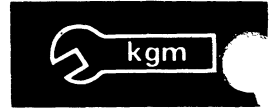

3. TIGHTENING TORQUE FOR NUTS OF FLARED

Use these torques for nut part of flared.

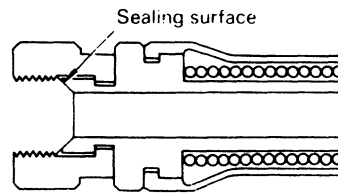

FS0068

Thread diameter of nut part (mm)	Width across flats of nut part (mm)	Tightening torque	
		kgm	Nm
14	19	2.5 ± 0.5	24.5 ± 4.9
18	24	5 ± 2	49 ± 19.6
22	27	8 ± 2	78.5 ± 19.6
24	32	14 ± 3	137.3 ± 29.4
30	36	18 ± 3	176.5 ± 29.4
33	41	20 ± 5	196.1 ± 49
36	46	25 ± 5	245.2 ± 49
42	55	30 ± 5	294.2 ± 49

COATING MATERIALS

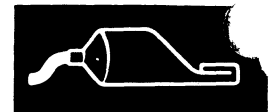

The recommended coating materials prescribed in the Shop Manuals are listed below.

Nomenclature	Komatsu code	Applications
Adhesives	LT-1A	Used to apply rubber pads, rubber gaskets, and cork plugs
	LT-1B	Used to apply resin, rubber, metallic and non-metallic parts when a fast, strong seal is needed.
	LT-2*	Preventing bolts, nuts and plugs from loosening and leaking oil.
	LT-3	Provides an airtight, electrically insulating seal. Used for aluminum surfaces.
Liquid gasket	LG-1	Used with gaskets and packings to increase sealing effect.
	LG-3	Heat-resistant gasket for precombustion chambers and exhaust piping.
	LG-4	Used by itself on mounting surfaces on the final drive and transmission cases. (Thickness after tightening: 0.07 – 0.08 mm)
	LG-5	Used by itself to seal grease fittings, tapered screw fittings and tapered screw fittings in hydraulic circuits of less than 50 mm in diameter.
Antifriction compound (Lubricant including molybdenum disulfide)	LM-P	Applied to bearings and taper shafts to facilitate press-fitting and to prevent sticking, burning or rusting.
Grease (Lithium grease)	G2-LI	Applied to bearings, sliding parts and oil seals for lubrication, rust prevention and facilitation of assembling work.
Vaseline	—	Used for protecting battery electrode terminals from corrosion.

WEIGHT TABLE

This weight table is a guide for use when transporting or handling components.

Unit: mm

Machine model	56
Serial No.	12001 and up
Engine assembly	123
● Engine	110
● PTO	7.5
● Hydraulic pump	5.3
Radiator assembly	4.2
Revolving frame	189
Canopy (ROPS)	81
Operator's Seat	7.5
Fuel tank	11
Hydraulic tank	20
8-spool control valve	18.5
1-spool control valve	4.3
Swing circle assembly	18
Swing motor	13.5
Center swivel joint	7.5
Track frame assembly	257
● Track frame	90.5
● Idler	7.5 x 2
● Idler cushionn	7.0 x 2
● Track roller	3.5 x 6
● Sprocket	5.5 x 2
Travel motor	15 x 2

Machine model	56
Serial No.	12001 and up
Track shoe assembly	
● Track shoe (230 mm width)	80 x 2
● Rubber shoe	57 x 2
Swing bracket assembly	14.5
Boom assembly	38.4
Arm assembly	19.4
Bucket assembly	23
Blade assembly	36
Boom cylinder assembly	10
Arm cylinder assembly	9
Bucket cylinder assembly	8.5
Boom swing cylinder assembly	8.0
Blade cylinder assembly	6.3

WEIGHT TABLE

This weight table is a guide for use when transporting or handling components.

Unit: mm

Machine model	76
Serial No.	
Engine assembly	159
● Engine	130
● Engine mount	12
● PTO	9
● Hydraulic pump	7.7
Radiator assembly	6.6
Revolving frame	338
Operator's cab (ROPS)	155
Canopy (ROPS)	81
Operator's Seat	10
Fuel tank	17
Hydraulic tank	34
6-spool control valve	16
2-spool control valve	6
1-spool control valve	4.3
Swing circle assembly	38.4
Swing motor	17
Center swivel joint	7.5
Track frame assembly	359
● Track frame	223
● Idler	20 x 2
● Idler cushionn	11 x 2
● Track roller	6 x 6
● Sprocket	8 x 2

Machine model	76
Serial No.	
Travel motor	30 x 2
Track shoe assembly	
● Track shoe (230 mm width)	136 x 2
● Rubber shoe	112 x 2
Boom swing bracket assembly	37
Boom assembly	73
Arm assembly	40
Bucket assembly	45
Blade assembly	108
Boom cylinder assembly	18.5
Arm cylinder assembly	18.2
Bucket cylinder assembly	14.5
Boom swing cylinder assembly	18.5
Blade cylinder assembly	9.8

56

LIST OF LUBRICANT AND WATER

RESERVOIR	KIND OF FLUID	AMBIENT TEMPERATURE					CAPACITY (l)		
		14 -10	32 0	50 10	68 20	86°F 30°C	Specified	Refill	
Engine oil pan	Engine oil	SAE 30					3.65	3.65	
		SAE 10W							
Final drive case (each)							0.3	0.3	
Track roller (1 piece)		SAE 30					0.02	—	
Idler (1 piece)							0.02	—	
Hydraulic tank		SAE 10W					24.3	18.3	
		SAE 10W-30							
		SAE 15W-40							
Fuel tank		Diesel fuel	ASTM D975 No. 2					20	—
Cooling system		Water	Add antifreeze					3.6	—

ASTM D975 No. 1

76

RESERVOIR	KIND OF FLUID	AMBIENT TEMPERATURE					CAPACITY (l)		
		14 -10	32 0	50 10	68 20	86°F 30°C	Specified	Refill	
Engine oil pan	Engine oil	SAE 30					3.1	3.1	
		SAE 10W							
Final drive case (each)							0.6	0.6	
Track roller (1 piece)		SAE 30					0.02	—	
Idler (1 piece)							0.02	—	
Hydraulic tank		SAE 10W					46	29	
		SAE 10W-30							
		SAE 15W-40							
Fuel tank		Diesel fuel	ASTM D975 No. 2					20	—
Cooling system		Water	Add antifreeze					3.6	—

ASTM D975 No. 1

ENGINE

11 STRUCTURE AND FUNCTION



Engine mount and PTO (Power Take-Off - 56.....	11- 2
Engine mount - 76.....	11- 3
PTO (Power Take-Off) - 76.....	11- 4
Radiator.....	11- 5
Fuel tank and piping.....	11- 9
Fuel control.....	11-11

ENGINE MOUNT AND PTO (Power Take-Off)

56

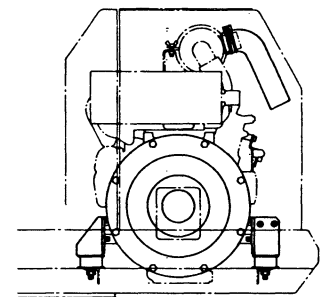
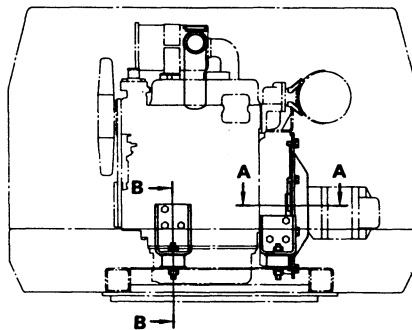
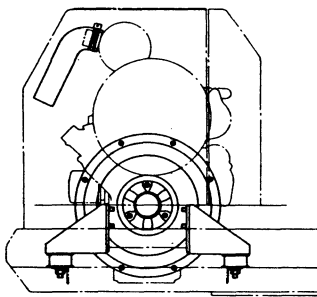
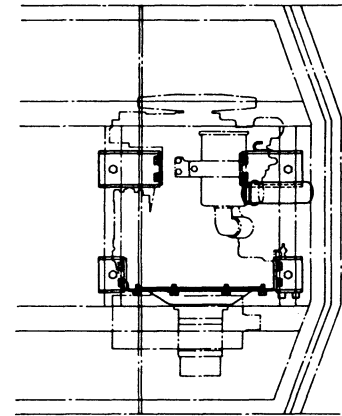
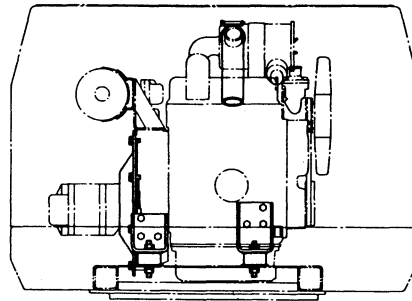
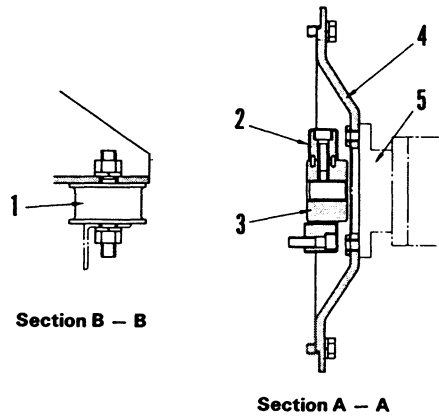

F20M05001

1. Cushion
2. Coupling ass'y
3. Joint
4. Cover
5. Tandem gear pump

ENGINE MOUNT

76

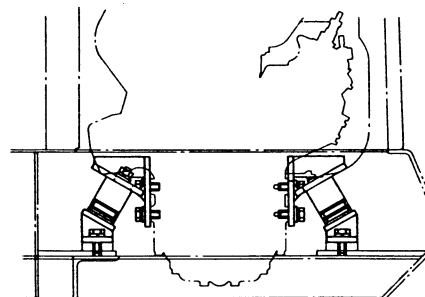
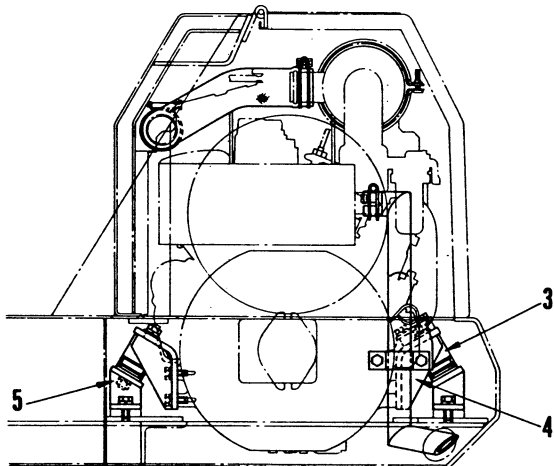
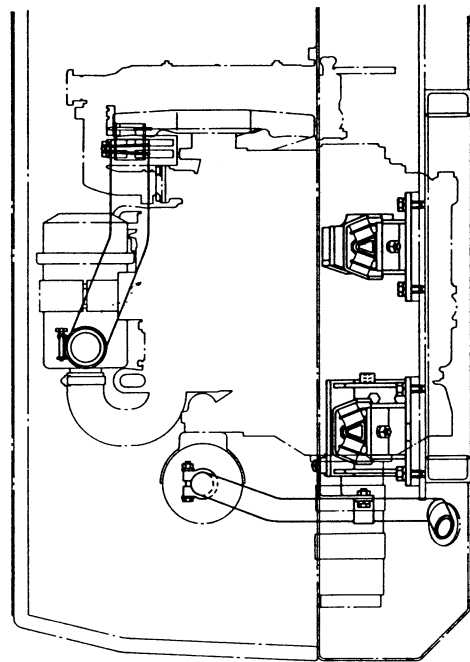
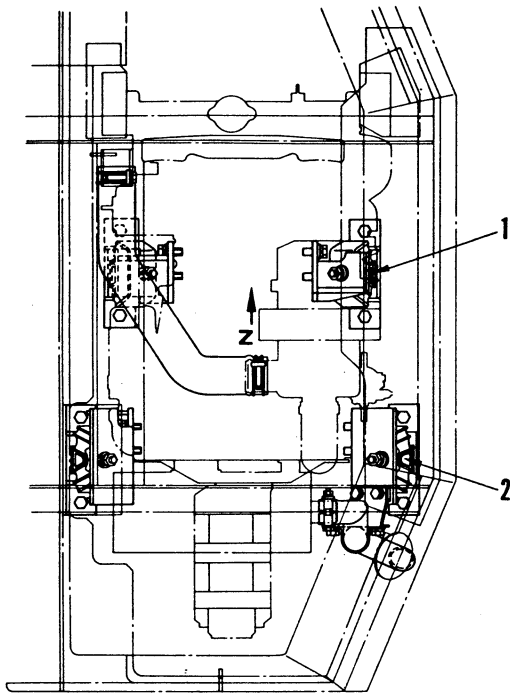

View Z

20NF2005

- 1. Front mount
- 2. Rear mount
- 3. Cushion
- 4. Engine side bracket
- 5. Chassis side bracket

PTO (Power Take-Off)

76

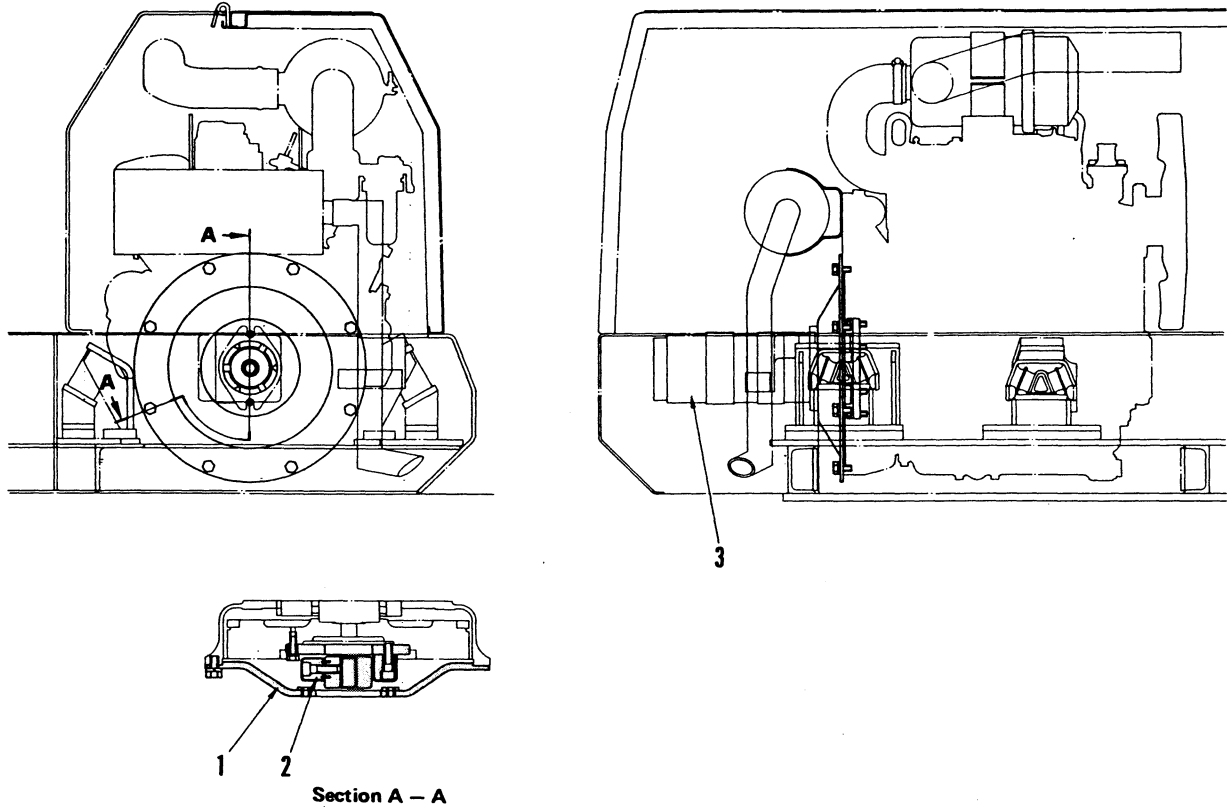

20NF2006

- 1. Cover
- 2. Coupling ass'y
- 3. Hydraulic pump

RADIATOR

56

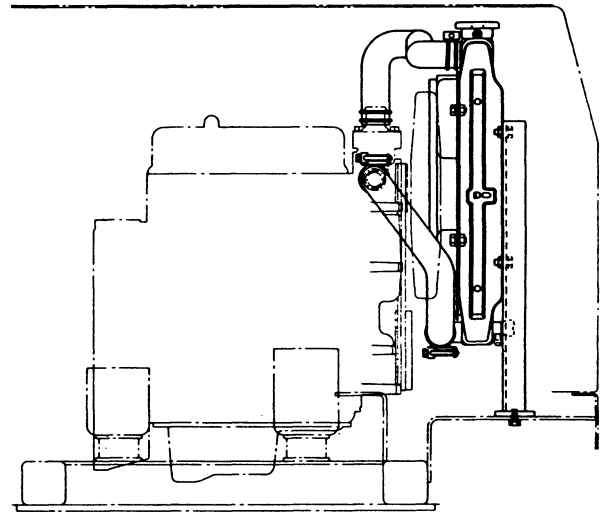
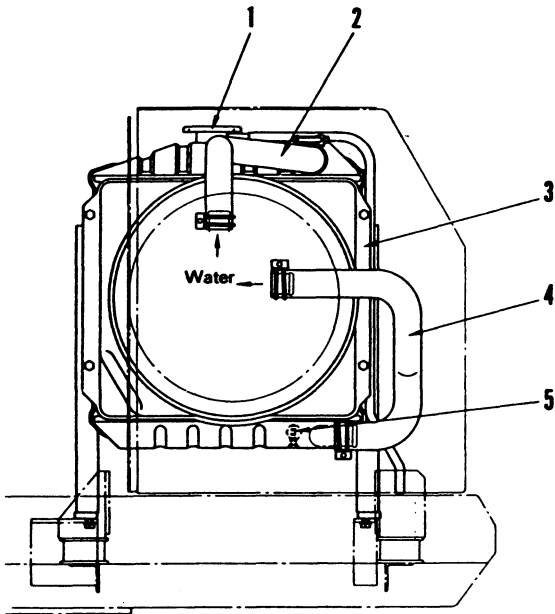
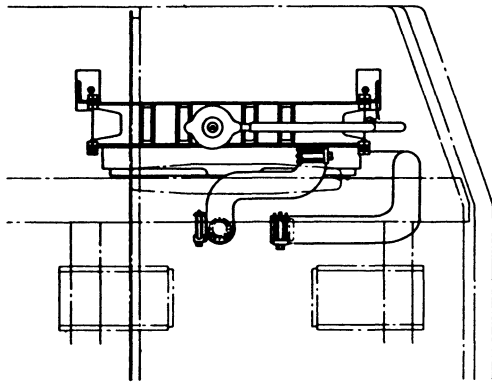

F20M05003

SPECIFICATIONS

Type: CD-2
Fin pitch: 4.0 mm
Pressure valve set pressure: $0.95 \pm 0.15 \text{ kg/cm}^2$
Vacuum valve set pressure: 0.05 kg/cm^2

1. Cap
2. Inlet hose
3. Radiator
4. Outlet hose
5. Drain plug

RADIATOR

56 (12001 & Above)

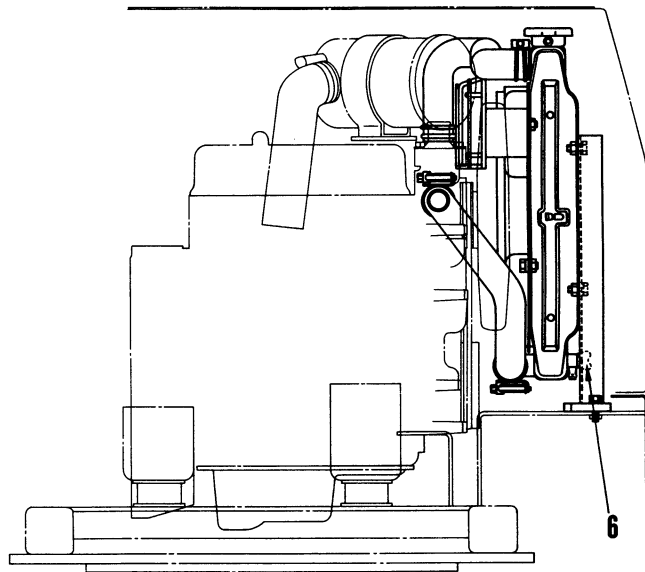
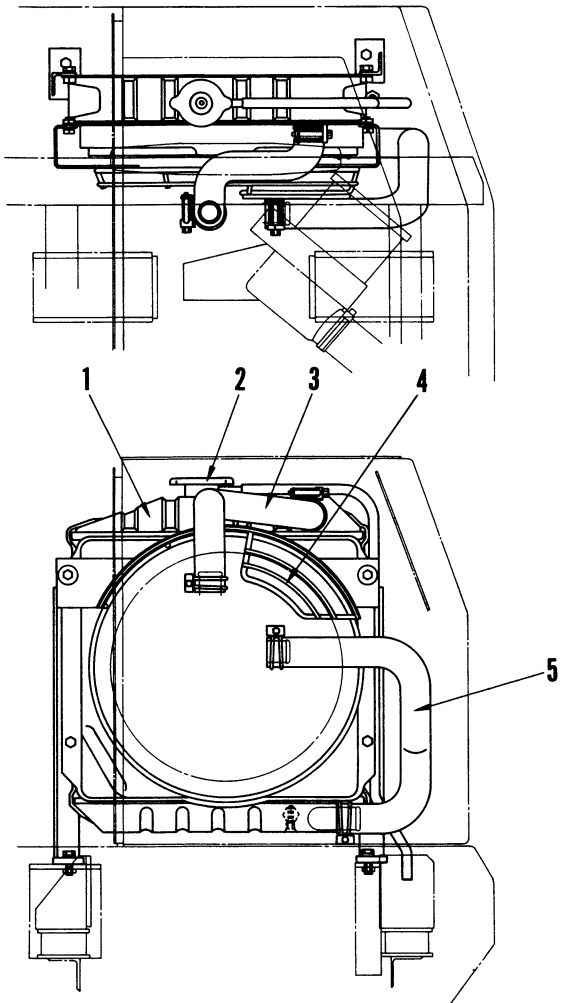

1. Radiator
2. Cap
3. Radiator inlet hose
4. Radiator guard
5. Radiator outlet hose
6. Drain valve

SPECIFICATIONS

- Type: CD-2
- Fin pitch: 4.0 mm
- Cap
 - Relief set pressure: $0.9 \pm 0.15 \text{ kg/cm}^2$
 - Suction set pressure: 0.05 kg/cm^2
- Capacity: 1.35l

RADIATOR

76

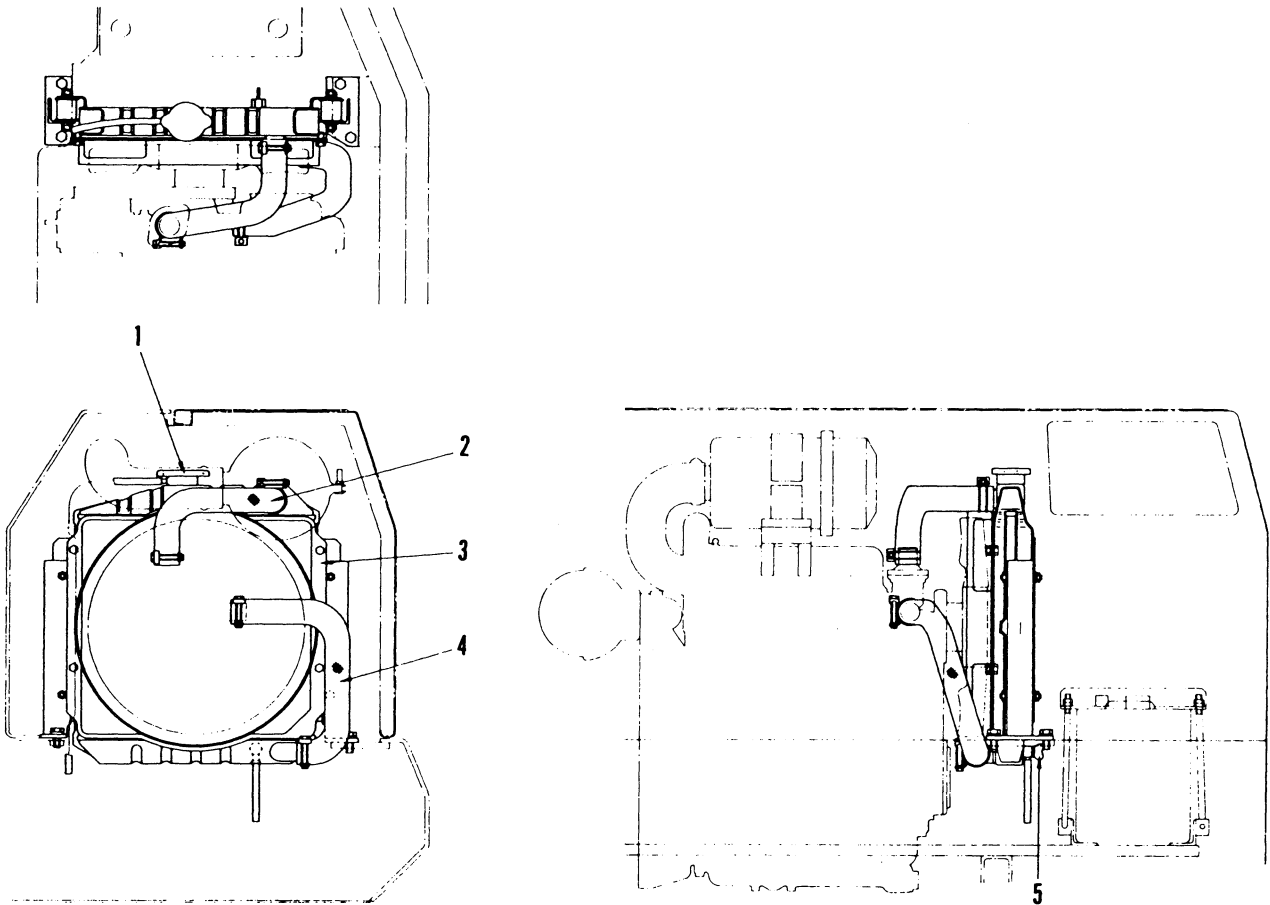

F20M05004

SPECIFICATIONS

Type:	CD-2
Fin pitch:	4.0 mm
Pressure valve set pressure:	$0.9 \pm 0.15 \text{ kg/cm}^2$
Vacuum valve set pressure:	0.05 kg/cm^2

1. Cap
2. Inlet hose
3. Radiator
4. Outlet hose
5. Drain plug

RADIATOR

76 (12001 & Above)

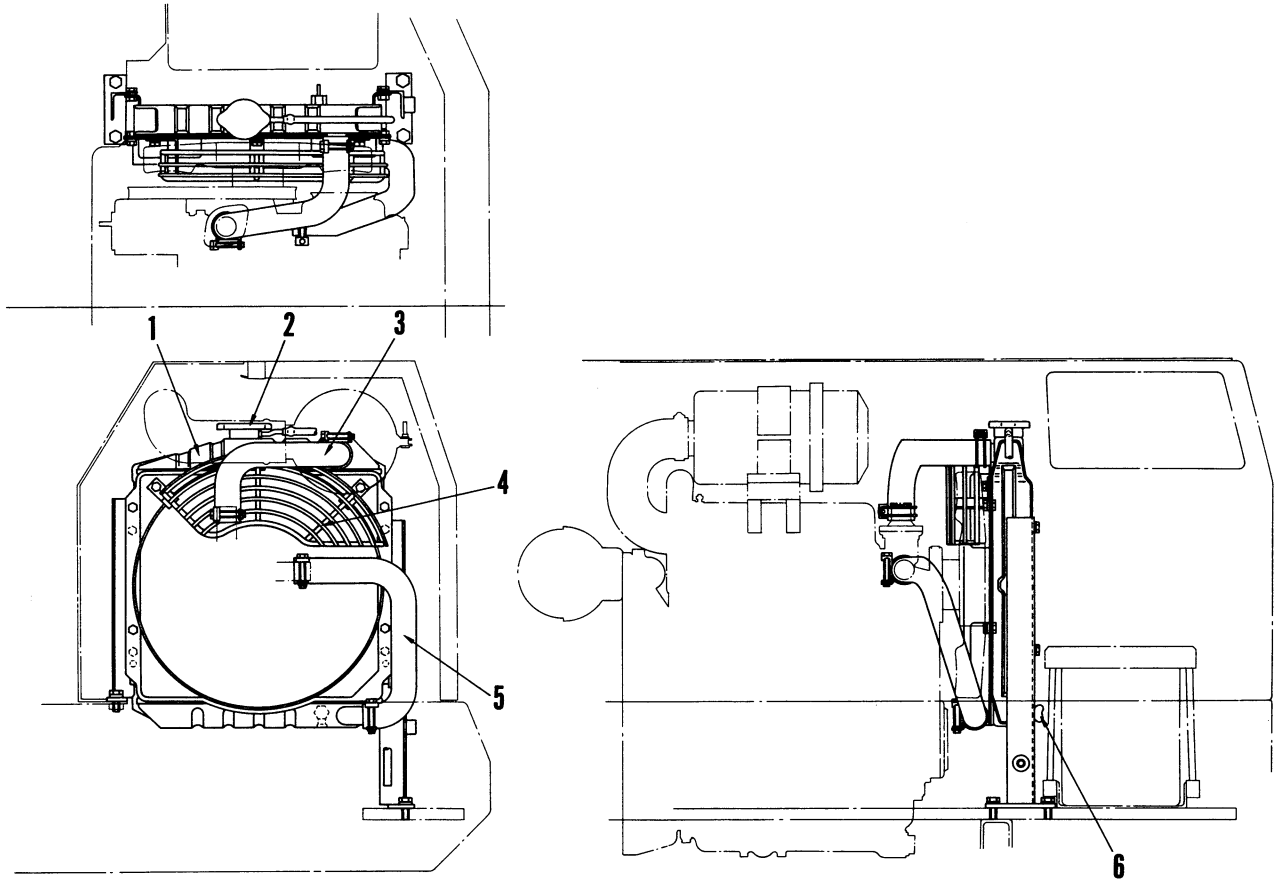

1. Radiator
2. Cap
3. Radiator inlet hose
4. Radiator guard
5. Radiator outlet hose
6. Drain valve

SPECIFICATIONS

- Type: CD-2
- Fin pitch: 4.0 mm
- Cap
 - Relief set pressure: $0.9 \pm 0.15 \text{ kg/cm}^2$
 - Suction set pressure: 0.05 kg/cm^2
- Capacity: 1.35l

FUEL TANK AND PIPING

56

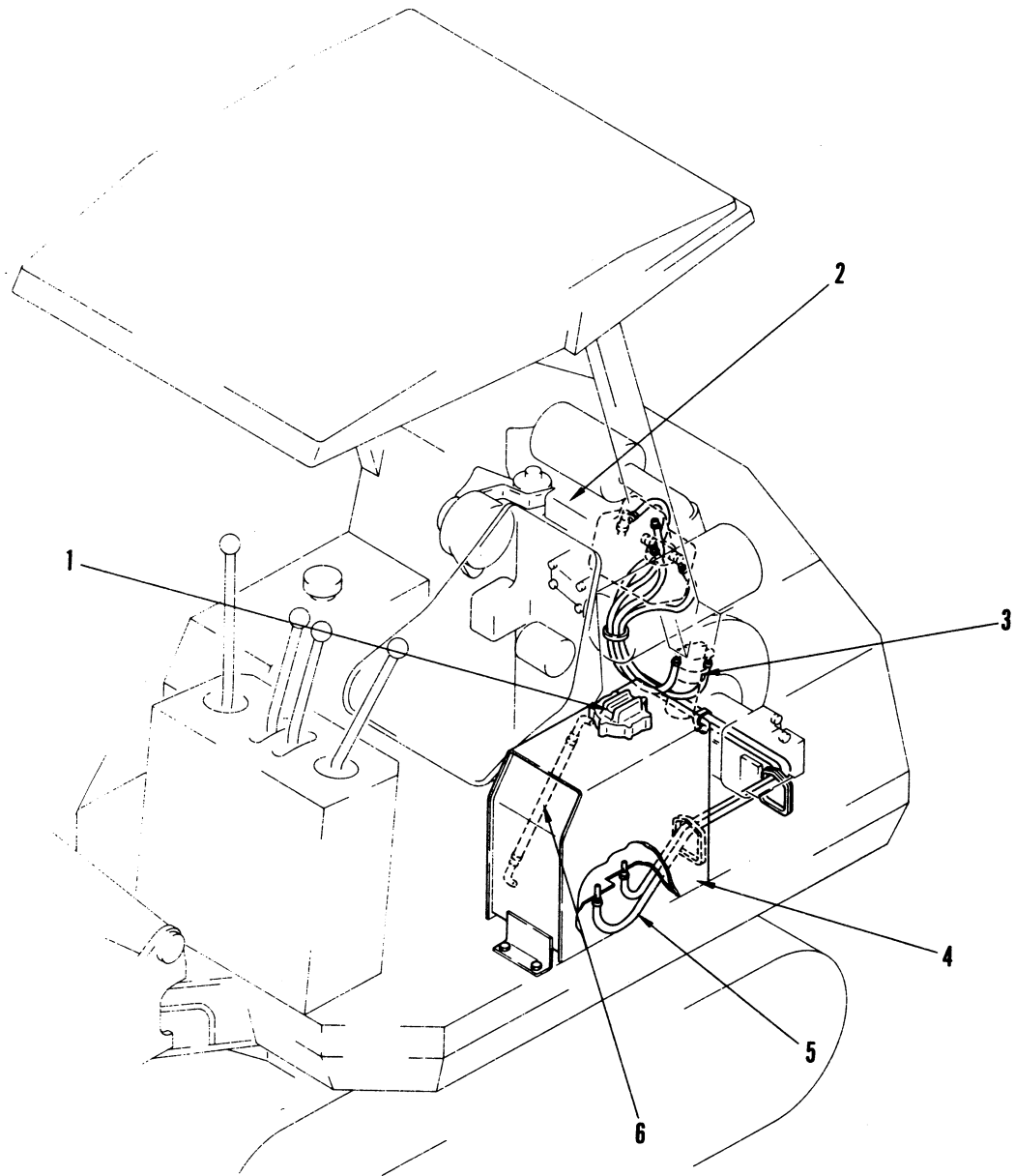

F20M05005

NOTE: For fuel system specifications and repair service, refer to the diesel servicing facilities for your area.

1. Fuel tank cap
2. Engine
3. Fuel filter
4. Fuel tank
5. Fuel hose
6. Fuel gauge

FUEL TANK AND PIPING

76

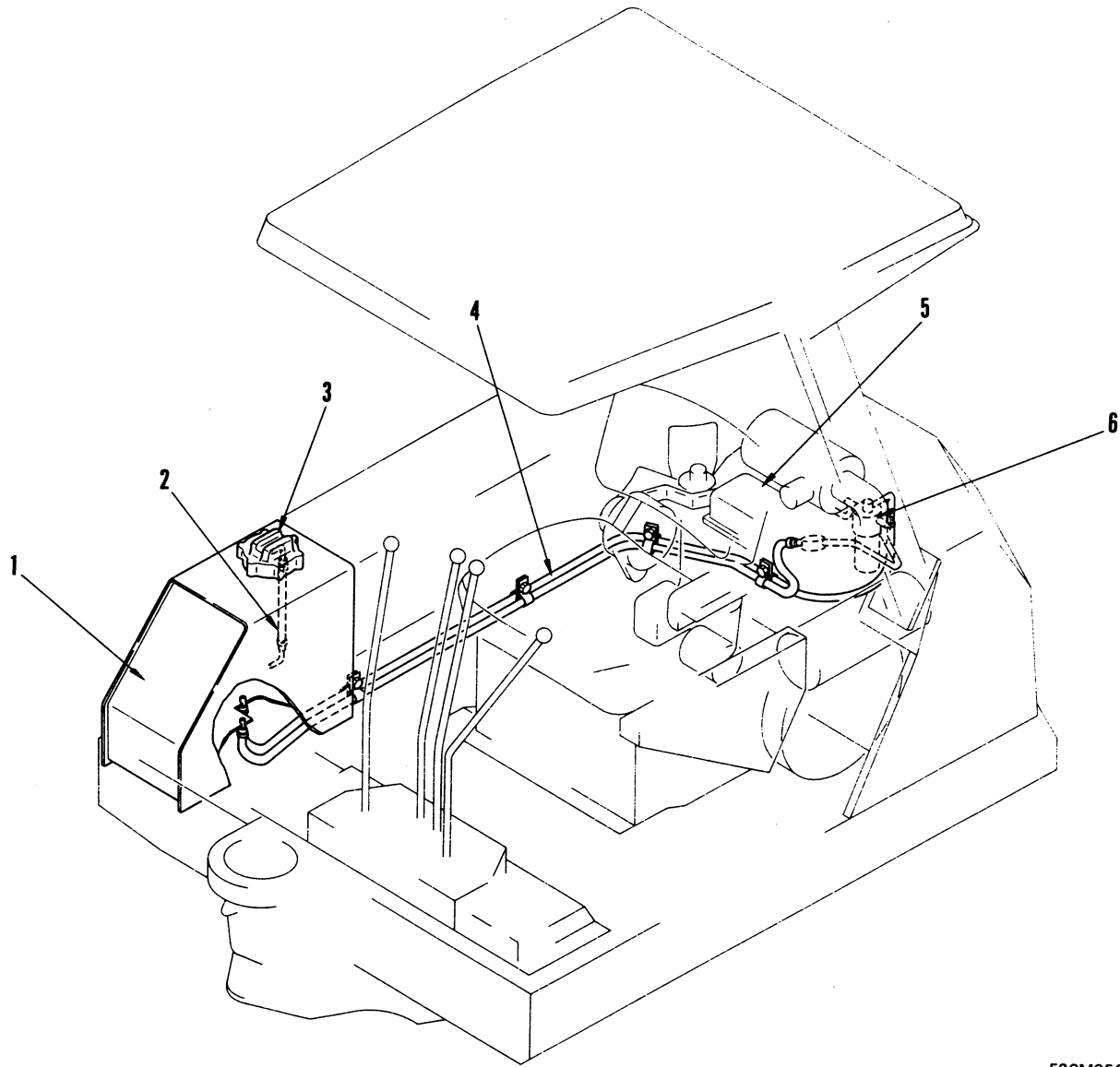

F20M05007

NOTE: For fuel system specifications and repair service, refer to the diesel servicing facilities for your area.

1. Fuel tank
2. Fuel gauge
3. Fuel tank cap
4. Fuel hose
5. Engine
6. Fuel filter

FUEL CONTROL

56

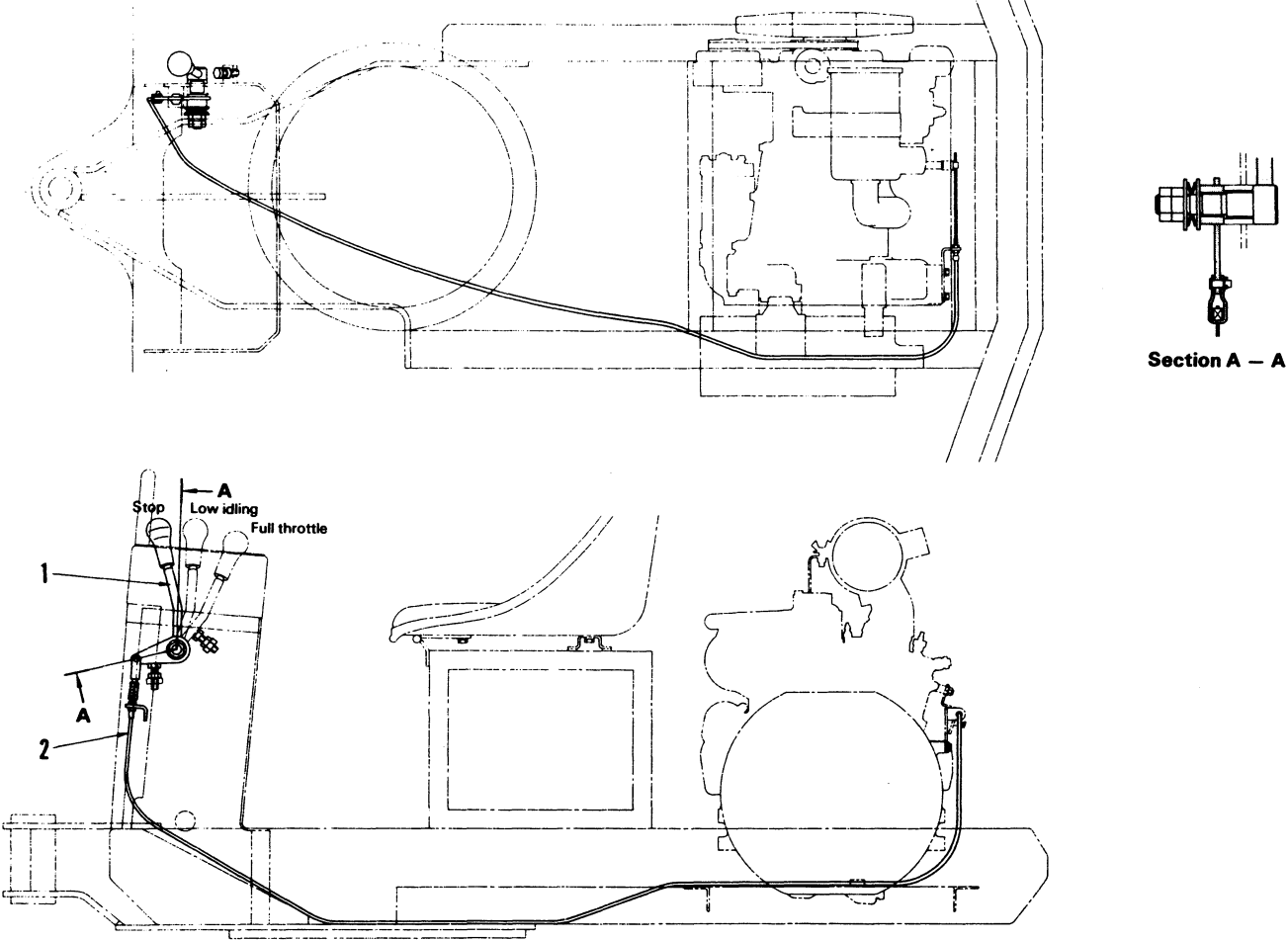

F20M05008

- 1. Fuel control lever
- 2. Fuel control cable

FUEL CONTROL

76

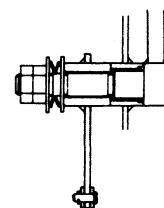
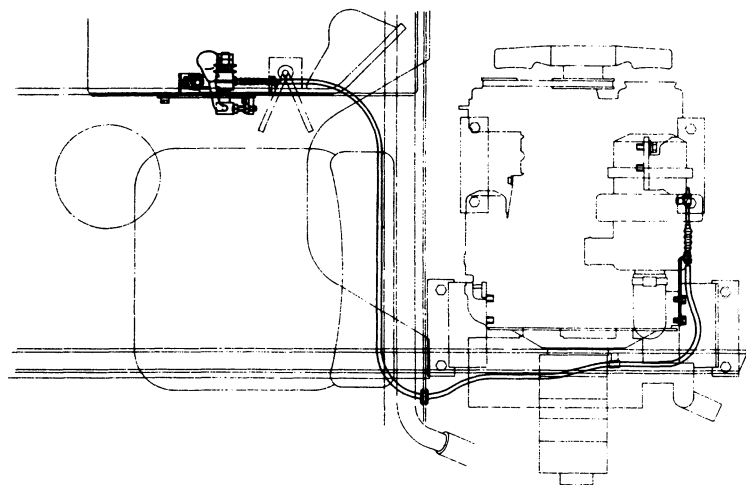

Section A - A

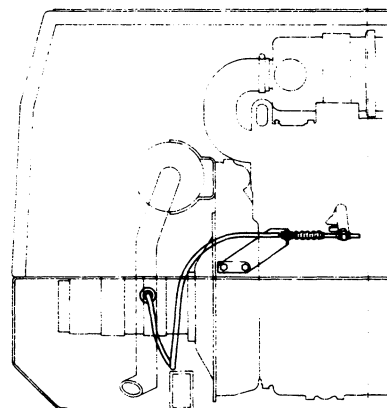
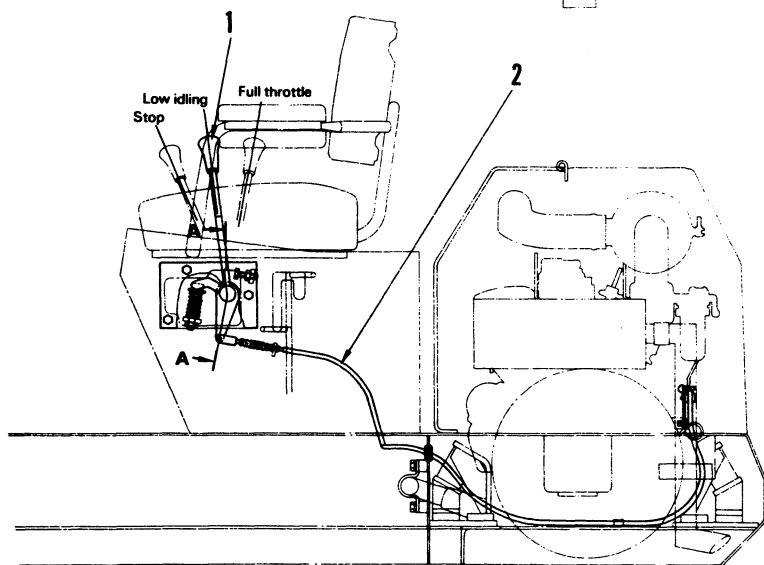

F20M05009

1. Fuel control lever
2. Fuel control cable

ENGINE

13 DISASSEMBLY AND ASSEMBLY



56		
	RADIATOR	
	Removal	13-2
	Installation	13-3
	ENGINE	
	Removal	13-4
	Installation	13-7
76		
	ENGINE	
	Removal	13-10
	Installation	13-13

★Use the following method for air bleeding when you start to operate hydraulic cylinder after reassembling cylinders, pumps and pipings.

1. Start engine, keep idling.
2. Operate hydraulic cylinder 4-5 cycles, but do not exceed beyond 100 mm of stroke end.
3. Continue to operate cylinder 3-4 cycles until stroke end.
4. After finishing above steps, keep normal engine speed.

NOTE: After long storage, same procedure is required.

REMOVAL OF RADIATOR ASSEMBLY

56

1. Loosen radiator drain plug (1) and drain water.
★ If the coolant contains antifreeze, dispose of it correctly.

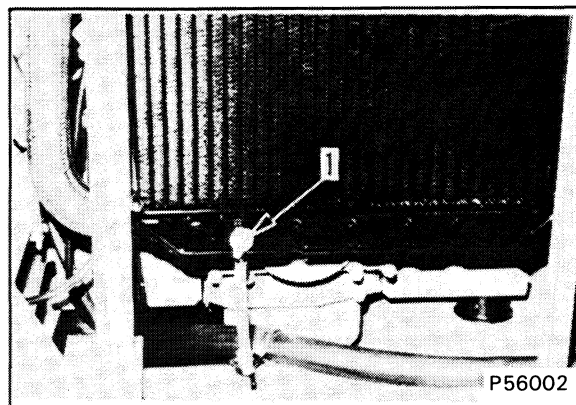

2. Open hood (2) and remove spring (3).
3. Remove hood (2) by removing four mounting bolts (4).

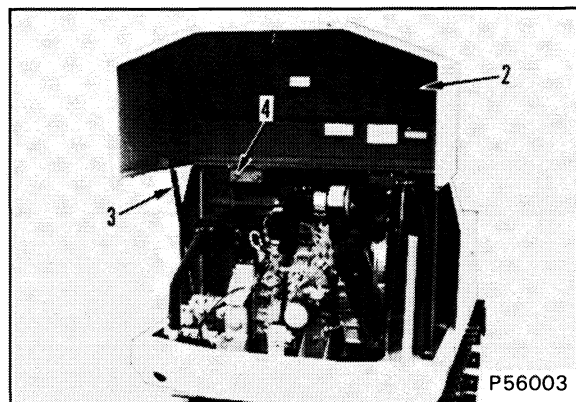

4. Remove canopy (6) by removing mounting bolts (5).

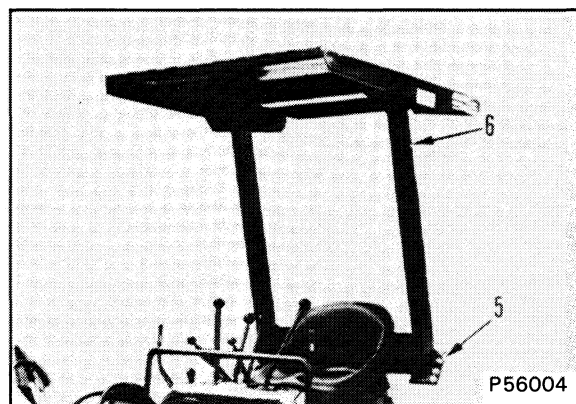

5. Remove cover (8) by removing ten mounting bolts (7).
6. Disconnect radiator inlet hose and outlet hose.
7. Remove radiator assembly.

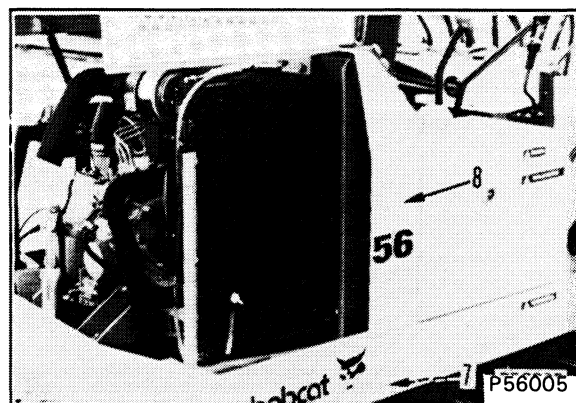



Suggest:

If the above button click is invalid.

Please download this document

first, and then click the above link

to download the complete manual.

Thank you so much for reading

INSTALLATION OF RADIATOR ASSEMBLY

56

1. Install radiator assembly (11).
2. Connect radiator inlet hose (9) and outlet hose (10).
3. Align cover (8) to the installation position and tighten with ten bolts (7).
4. Align canopy (6) to the installation position and tighten with bolts (5).
5. Align hood (2) to the installation position and tighten with bolts (4).
6. Install spring (3).
7. Tighten radiator drain plug (1), remove the cap.

Premix coolant before adding it to the system.

Use 50% anti-freeze and 50% water. This mixture will prevent freezing to approximately -34°F (-36°C), and also raises the boiling point and improves corrosion resistance.

Never exceed a 70/30 anti-freeze/water ratio. Never add 100% anti-freeze to the system. Never use supplemental coolant additives.

Use only anti-freeze containing less than 0.1% of silicate (measured as anhydrous alkali metasilicate).

Drain, flush, and refill system with correct pre-mixed coolant whenever coolant becomes discolored.

Add coolant to specific level.

Replace the radiator cap.

- ★ Run the engine to circulate the water through the cooling system. Then check the water level again.

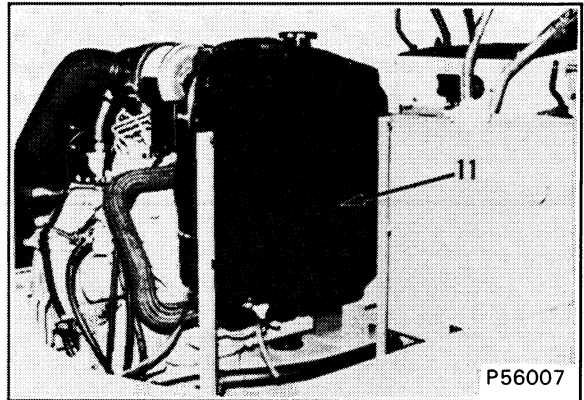
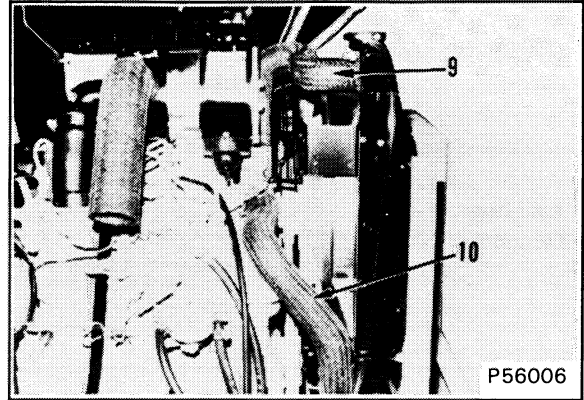

<https://www.ebooklibonline.com>

Hello dear friend!

Thank you very much for reading.

Enter the link into your browser.

The full manual is available for immediate download.

<https://www.ebooklibonline.com>