

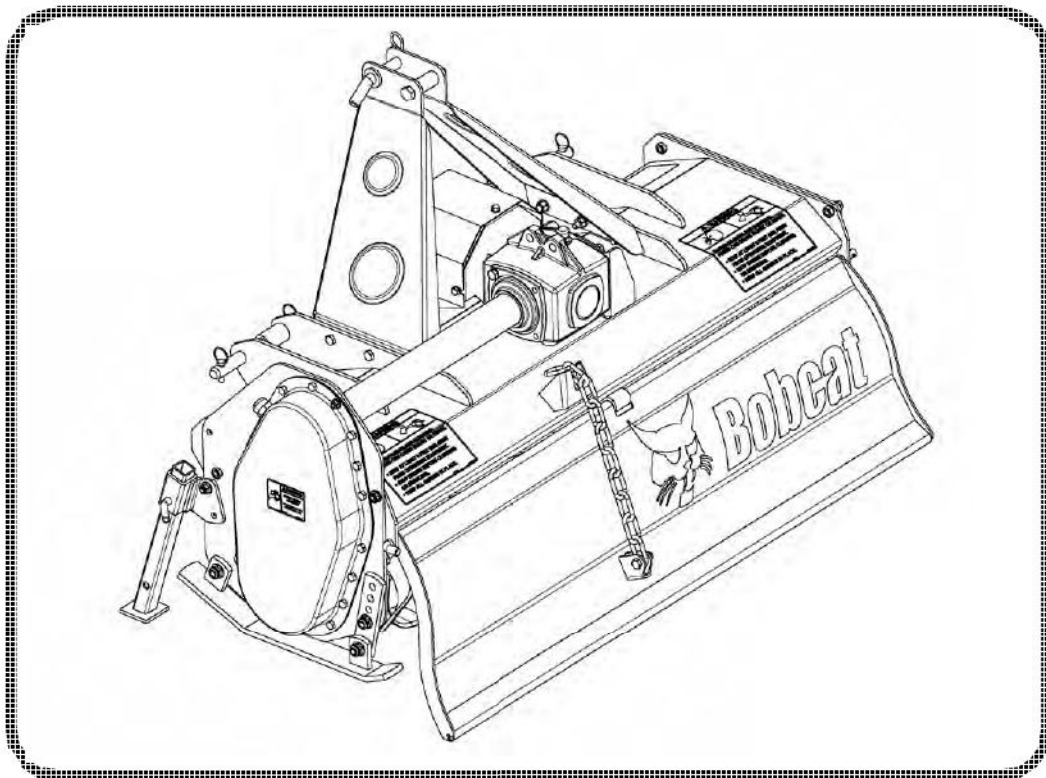

Bobcat®

Service Manual Three-Point Tiller

(TILLER 3TIL48) S/N ADL700101 & Above
(TILLER 3TIL60) S/N ADKY00101 & Above
(TILLER 3TIL74) S/N ADL400101 & Above



Dealer Copy -- Not for Resale



MAINTENANCE SAFETY



WARNING







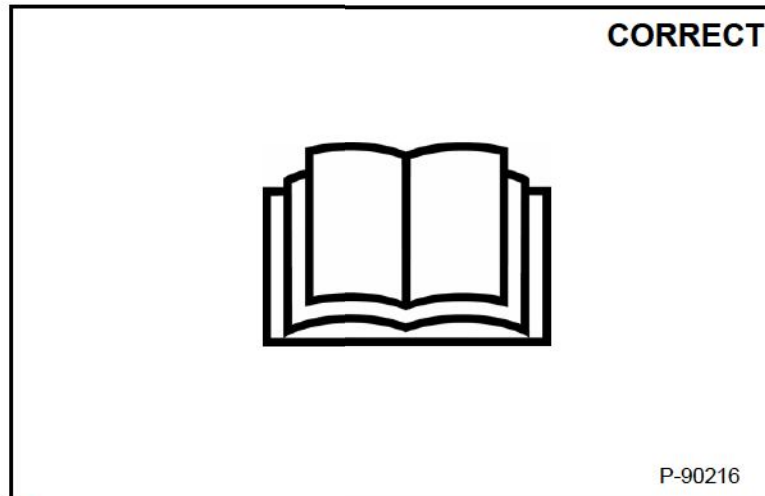

Instructions are necessary before operating or servicing machine. Read and understand the Operation & Maintenance Manual, Operator's Handbook and signs (decals) on machine. Follow warnings and instructions in the manuals when making repairs, adjustments or servicing. Check for correct function after adjustments, repairs or service. Untrained operators and failure to follow instructions can cause injury or death.

W-2003-0807



Safety Alert Symbol: This symbol with a warning statement, means: "Warning, be alert! Your safety is involved!" Carefully read the message that follows.



-  Never service attachments / implements without instructions. See Operation & Maintenance Manual and Attachment / Implement Service Manual.
-  Cleaning and maintenance are required daily.
-  Never service or adjust attachment / implement with the engine running unless instructed to do so in manual.
-  Always lower the attachment / implement to the ground before lubricating or servicing.
-  Avoid contact with leaking hydraulic fluid or diesel fuel under pressure. It can penetrate skin or eyes.
-  Stop, cool and clean engine of flammable materials before checking fluids.
-  Keep body, loose objects and clothing away from moving parts, electrical contacts, hot parts and exhaust.
-  Safety glasses are needed for eye protection from electrical arcs, battery acid, compressed springs, fluids under pressure and flying debris or when tools are used. Use eye protection approved for type of welding.

Dealer Copy -- Not for Resale

MSW30-0409

CONTENTS

SAFETY & MAINTENANCE	10-01
MAINFRAME	20-01
SPECIFICATIONS	SPEC-01
ALPHABETICAL INDEX	INDEX-01

Dealer Copy -- Not for Resale

FOREWORD

SERIAL NUMBER LOCATION	1-7
Implement Serial Number	1-7
DELIVERY REPORT	1-7
IMPLEMENT IDENTIFICATION	1-8

<https://www.ebooklibonline.com>

Hello dear friend!

Thank you very much for reading.

Enter the link into your browser.

The full manual is available for immediate download.

<https://www.ebooklibonline.com>

SERIAL NUMBER LOCATION

Implement Serial Number

Figure 1

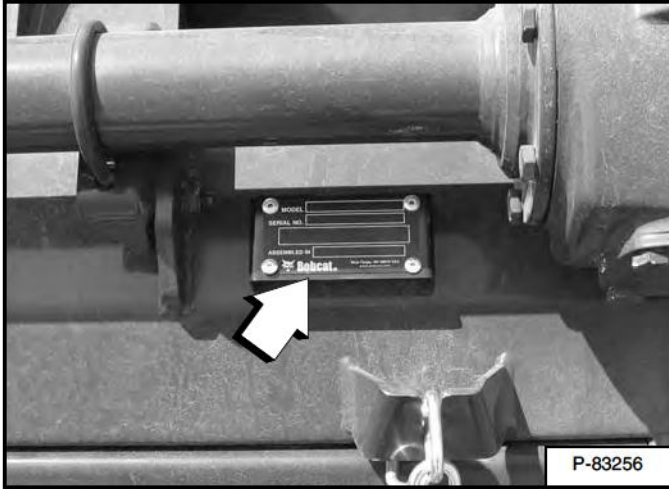

Always use the serial number of the planer when requesting service information or when ordering parts. Early or later models (identification made by serial number) may use different parts, or it may be necessary to use a different procedure in doing a specific service operation [Figure 1].

DELIVERY REPORT

Figure 2

The delivery report [Figure 2] must be completed by the dealer and signed by the owner or operator when the Bobcat planer is delivered. An explanation of the form must be given to the owner.

IMPLEMENT IDENTIFICATION

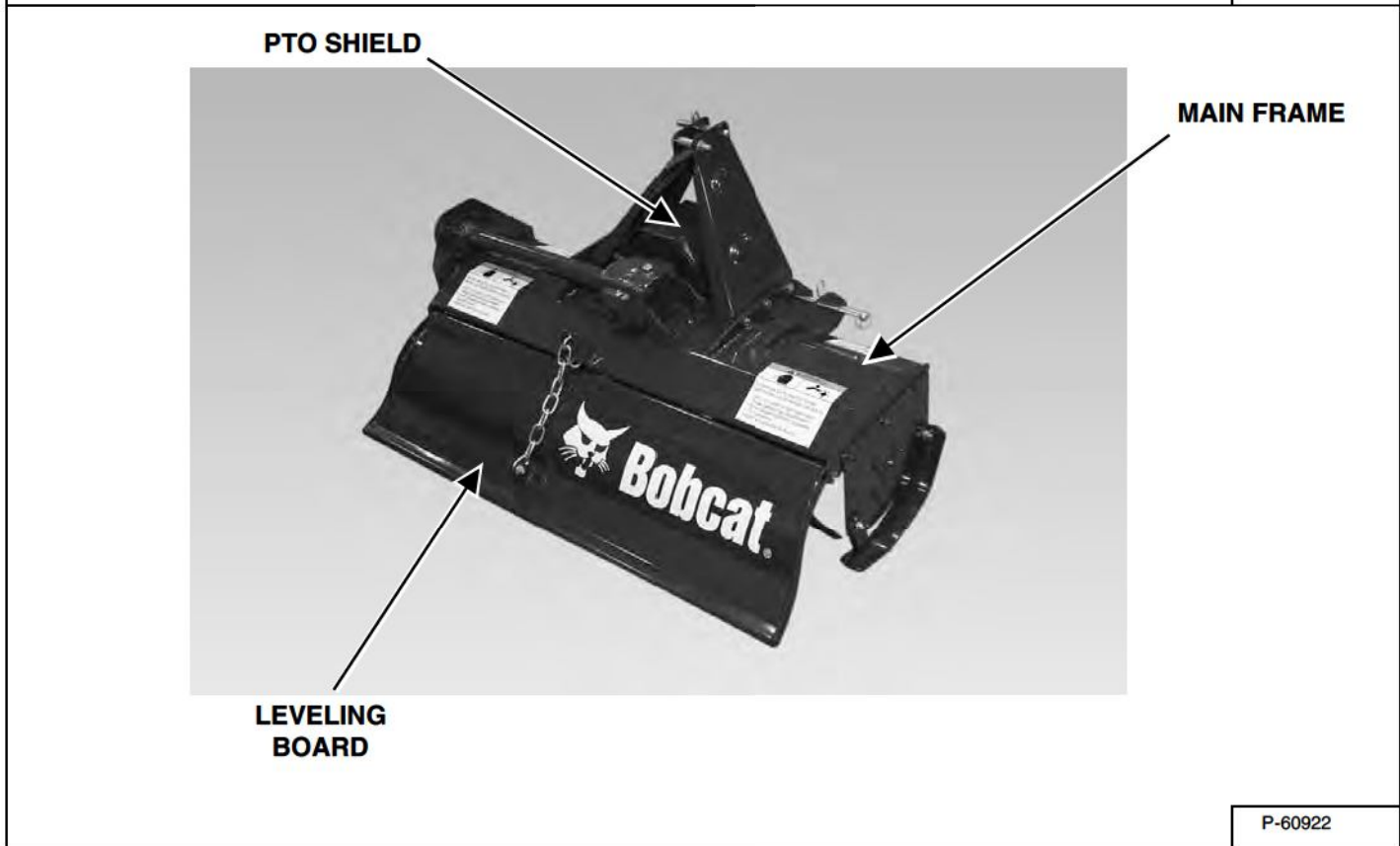
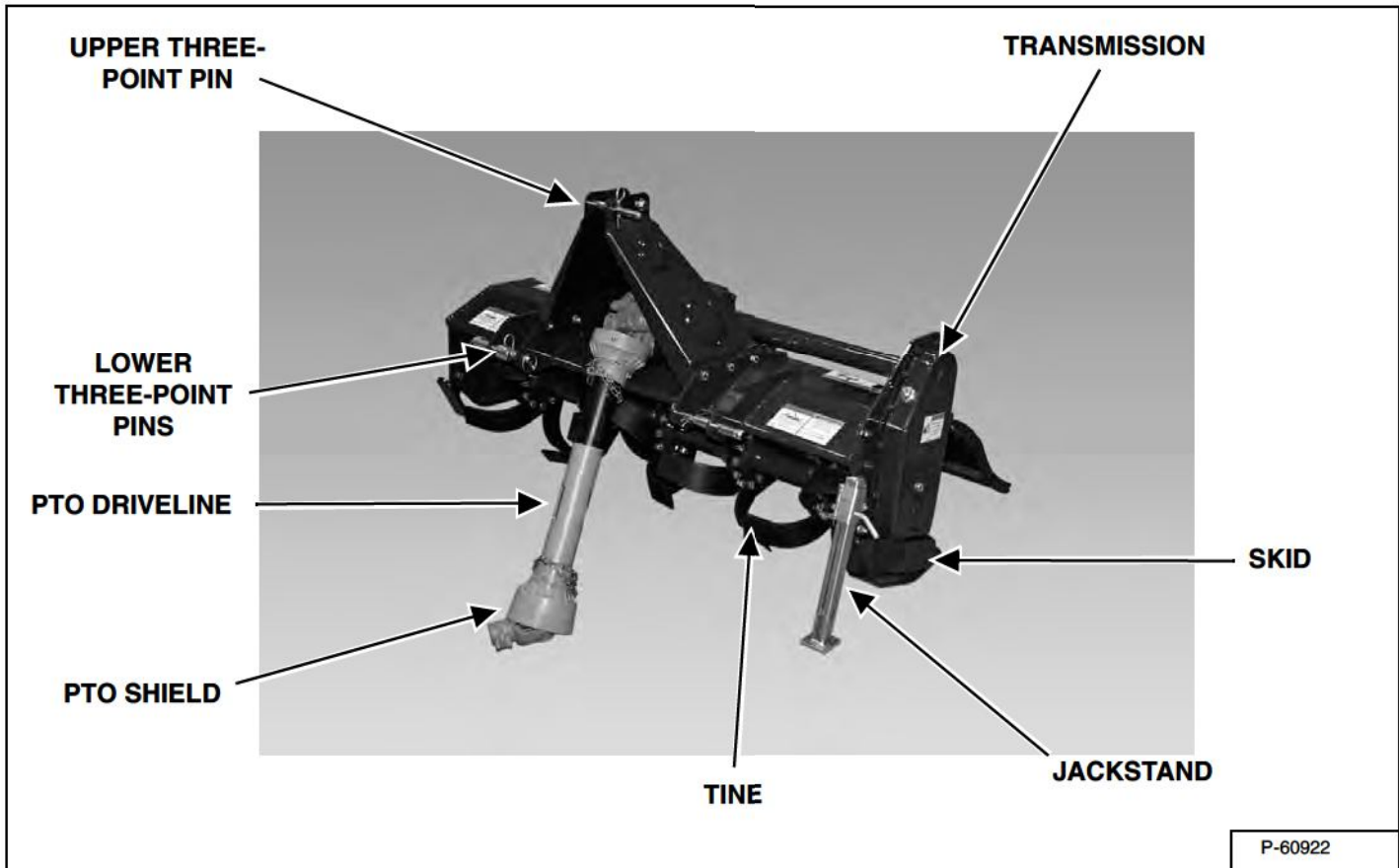

Dealer Copy -- Not for Resale

SAFETY & MAINTENANCE

TROUBLESHOOTING	10-10-1
Chart	10-10-1
SERVICE SCHEDULE	10-20-1
Description	10-20-1
DAILY INSPECTION	10-30-1
Implement Mounting Frame	10-30-1
Three-Point Hitch	10-30-1
LUBRICATING THE IMPLEMENT	10-40-1
Lubrication Locations	10-40-1
REGULAR MAINTENANCE ITEMS	10-50-1
Skids	10-50-1
Tines	10-50-1
Gearbox Fluid	10-50-2
Transmission Fluid	10-50-2
Cleaning The Three-Point Tiller	10-50-3
GEARBOX FLUID CHANGE	10-60-1
48" Tiller	10-60-1
60" & 74" Tiller	10-60-1
REMOVAL AND INSTALLATION	10-70-1
Tine Replacement	10-70-1
Skid Replacement	10-70-1
Leveling Board Replacement	10-70-2
Jack Stand Replacement	10-70-2
IMPLEMENT STORAGE AND RETURN TO SERVICE	10-80-1
Storage	10-80-1
Return to Service	10-80-1

Dealer Copy -- Not for Resale

TROUBLESHOOTING

Chart

 WARNING	<p>Instructions are necessary before operating or servicing machine. Read and understand the Operation & Maintenance Manual, Operator's Handbook and signs (decals) on machine. Follow warnings and instructions in the manuals when making repairs, adjustments or servicing. Check for correct function after adjustments, repairs or service. Untrained operators and failure to follow instructions can cause injury or death.</p> <p style="text-align: right;">W-2003-0903</p>
--	--

If the attachment is not working correctly, check the hydraulic system of the machine thoroughly before making any repairs on the attachment. Attachment problems can be affected by a hydraulic system that is not operating to specifications. Connect a flow meter to the machine to check the hydraulic pump output, relief valve setting and tube lines to check flow and pressure. (See the machine's Service Manual for the correct procedure to connect the flow meter.)

Use the following troubleshooting chart to locate and correct problems which most often occur with the attachment.

PROBLEM	CAUSE	CORRECTION
Will not till deep enough.	Skid shoes set too high.	Adjust skid shoes.
	Top three-point link adjusted incorrectly.	Adjust top link.
	Tines are worn too much.	Replace worn tines.
Rotor will not turn.	PTO not engaged.	Engage rear-PTO.
	PTO slip clutch worn excessively.	Replace slip clutch. See your Bobcat dealer for service.
	Rotor is obstructed.	Remove obstruction from rotor.
Poor tilling quality.	Tines are worn too much.	Replace tine(s).
	Missing or damaged tine(s).	Replace tine(s).
	Ground speed too fast.	Drive at slower ground speed.
Tillage is not smooth.	Ground speed too fast.	Drive at slower ground speed.
	Leveling board adjusted incorrectly.	Adjust leveling board correctly.

Dealer Copy -- Not for Resale

SERVICE SCHEDULE

Description

 WARNING	<p>Instructions are necessary before operating or servicing machine. Read and understand the Operation & Maintenance Manual, Operator's Handbook and signs (decals) on machine. Follow warnings and instructions in the manuals when making repairs, adjustments or servicing. Check for correct function after adjustments, repairs or service. Untrained operators and failure to follow instructions can cause injury or death.</p> <p style="text-align: right;">W-2003-0903</p>
--	--

Maintenance work must be done at regular intervals. Failure to do so will result in excessive wear and early failures. The service schedule is a guide for correct maintenance of the Bobcat product.

SERVICE SCHEDULE		HOURS		
ITEM	SERVICE REQUIRED	8	50	500
Rotor Support Bearing	Grease rotor support.			
PTO Driveline	Grease the PTO knuckles and driveline.			
Gearbox	Check the oil level.			
Side Transmission	Check the oil level.			
Mounting Hardware	Check tightness of all mounting hardware.			
Gearbox	Change the oil.		[1]	
Side Transmission	Change the oil.		[1]	

[1] Service at first 50 hours and thereafter as scheduled.

Dealer Copy -- Not for Resale

DAILY INSPECTION

Implement Mounting Frame

Figure 10-30-1

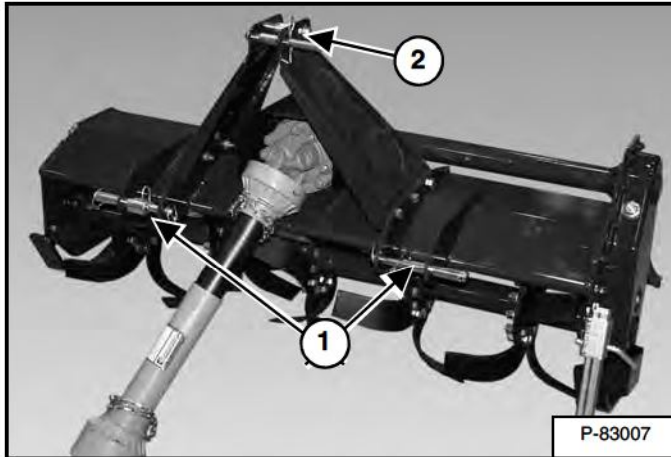

Inspect the lower three-point mounts and lower mounting pins (Item 1) and the upper three-point mount and pin (Item 2) [Figure 10-30-1], along with all hardware and welds on the three-point tiller for wear and damage each time the three-point tiller is removed from the compact tractor.

Three-Point Hitch

! WARNING

AVOID INJURY OR DEATH

- Disengage the PTO (rear and mid), engage the parking brake, stop the engine and make sure all rotating components are completely stopped before connecting, disconnecting, adjusting or cleaning any PTO driven equipment.
- Always keep PTO shields and all guards in place when using PTO driven equipment.
- Disengage PTO (rear and mid) for road travel.
- Keep hands, feet and clothing away.

W-2568-0907

! WARNING

AVOID INJURY OR DEATH

The parking brake must be engaged before leaving the operator's seat. Rollaway can occur because the transmission may not prevent machine movement. Lock the brake pedals together before activating the parking brake.

W-2656-0807

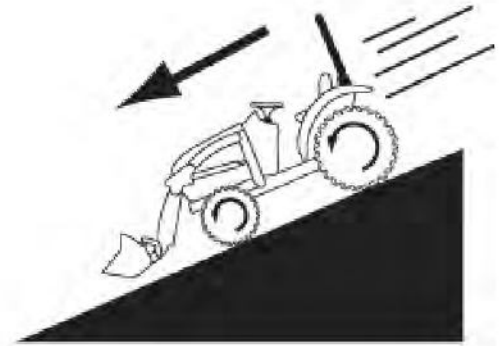

! WARNING

AVOID INJURY OR DEATH

The parking brake must be engaged before leaving the operator's seat. Rollaway can occur because the transmission may not prevent machine movement. Lock the brake pedals together before activating the parking brake.

W-2656-0807

Figure 10-30-2

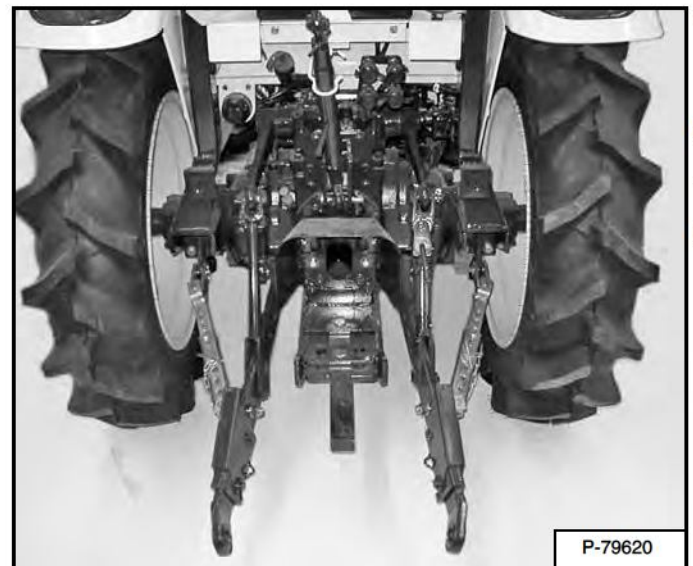

Inspect the three-point hitch linkage, PTO shaft splines (if required), guards, and shields. Replace if damaged or missing [Figure 10-30-2]. Repair broken or loose parts.

See the compact's tractor Operation & Maintenance Manual for detailed information on inspecting the compact tractor.

LUBRICATING THE IMPLEMENT

Lubrication Locations

! WARNING

AVOID INJURY OR DEATH

The parking brake must be engaged before leaving the operator's seat. Rollaway can occur because the transmission may not prevent machine movement. Lock the brake pedals together before activating the parking brake.

W-2656-0807

! WARNING

AVOID INJURY OR DEATH

- Disengage the PTO (rear and mid), engage the parking brake, stop the engine and make sure all rotating components are completely stopped before connecting, disconnecting, adjusting or cleaning any PTO driven equipment.
- Always keep PTO shields and all guards in place when using PTO driven equipment.
- Disengage PTO (rear and mid) for road travel.
- Keep hands, feet and clothing away.

W-2568-0907

! WARNING

AVOID INJURY OR DEATH

Wear safety glasses to prevent eye injury when any of the following conditions exist:

- When fluids are under pressure.
- Flying debris or loose material is present.
- Engine is running.
- Tools are being used.

W-2019-0907

Lubricate the three-point tiller as specified for the best performance of the three-point tiller (See SERVICE SCHEDULE on Page 10-20-1.)

Always use a good quality lithium base multi-purpose grease when lubricating the three-point tiller.

Lubricate the following:

Figure 10-40-1

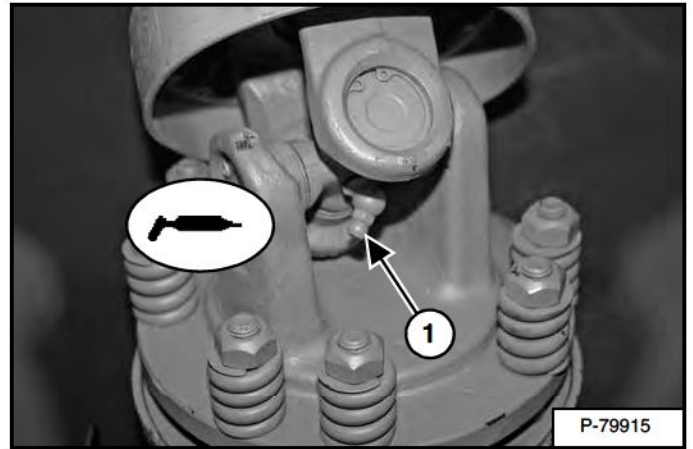

1. PTO Shaft (Gearbox Side) [Figure 10-40-1].

NOTE: The PTO Shield was removed for clarity.

Figure 10-40-2

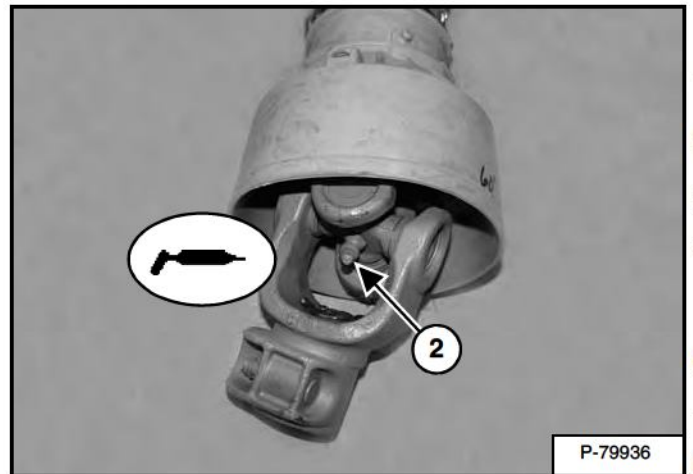

2. PTO Shaft (Compact Tractor Side) [Figure 10-40-2].

Dealer Copy -- Not for Resale

LUBRICATING THE IMPLEMENT (CONT'D)

Lubrication Locations (Cont'd)

Figure 10-40-3

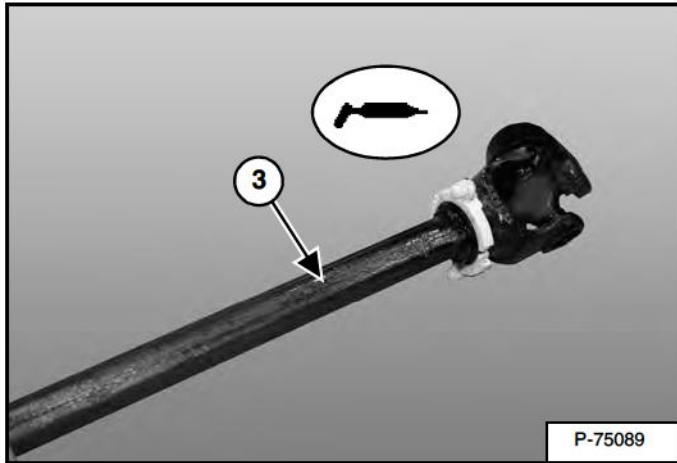

3. PTO Driveline Shaft [Figure 10-40-3].

Figure 10-40-4

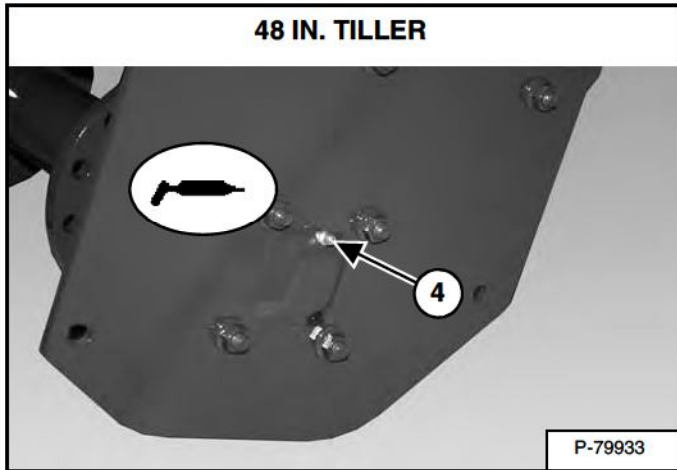

4. Rotary Shaft (Opposite Of Transmission) [Figure 10-40-4].

Figure 10-40-5

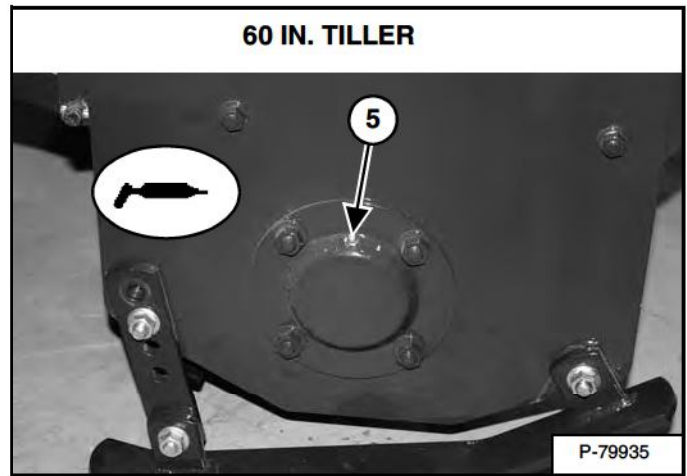

5. Rotary Shaft (Opposite Of Transmission) [Figure 10-40-5].

Figure 10-40-6

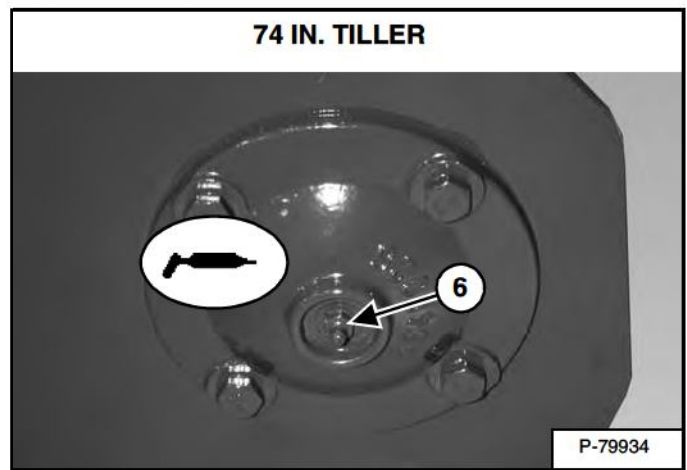

6. Rotary Shaft (Opposite Of Transmission) [Figure 10-40-6].

REGULAR MAINTENANCE ITEMS

WARNING

AVOID INJURY OR DEATH

Securely block up the implement before working underneath.

W-2565-0207

WARNING

AVOID INJURY OR DEATH

Wear safety glasses to prevent eye injury when any of the following conditions exist:

- When fluids are under pressure.
- Flying debris or loose material is present.
- Engine is running.
- Tools are being used.

W-2019-0907

Skids

Figure 10-50-1

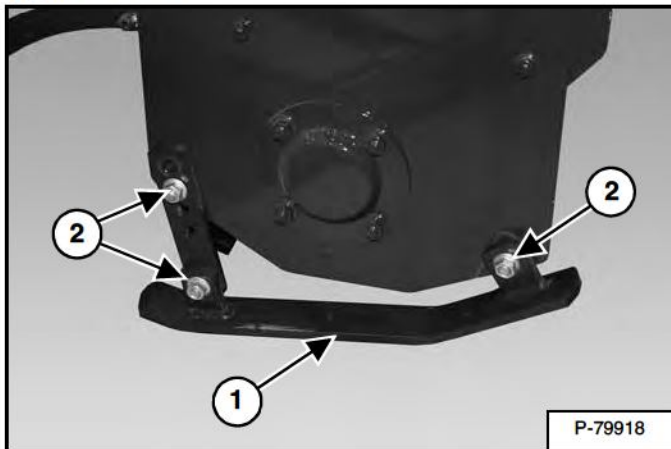

Inspect the skids (Item 1) and welds for cracks, damage and / or excessive wear. Replace the skids as needed. Replace or tighten bolts and nuts (Item 2) [Figure 10-50-1] to 60 ft.-lb. (81 N•m) torque.

Tines

Figure 10-50-2

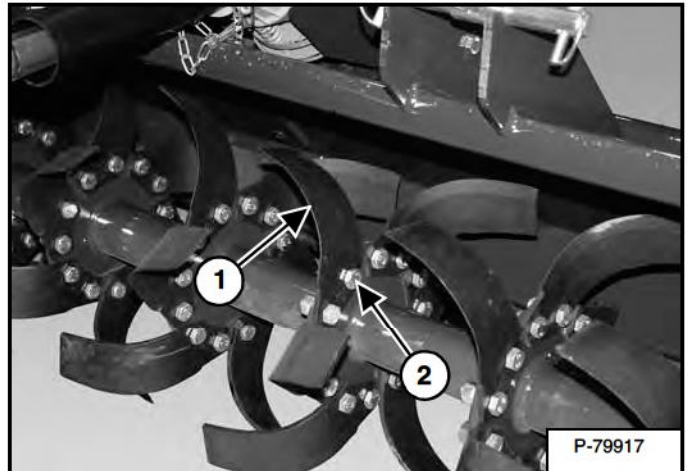

Check tiller for any bent or worn tines (Item 1). Replace the tines as needed. Check tines for any loose or missing bolts and nuts (Item 2) [Figure 10-50-2]. Replace or tighten bolts and nuts to 60 ft.-lb. (81 N•m) torque.

Dealer Copy -- Not for Resale

REGULAR MAINTENANCE ITEMS (CONT'D)

Gearbox Fluid

Figure 10-50-3

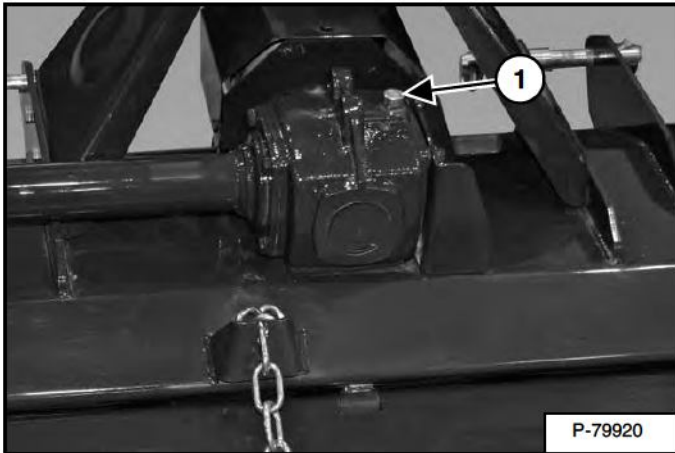

Remove the plug / dipstick (Item 1) [Figure 10-50-3] to check the gearbox fluid level.

Figure 10-50-4

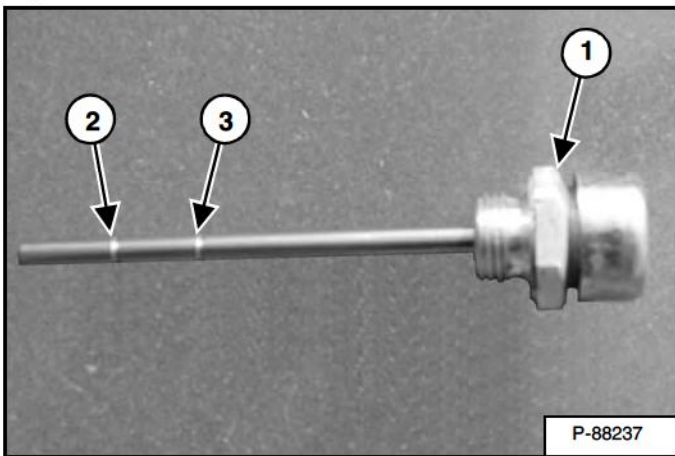

Check the fluid level on the plug/dipstick (Item 1) [Figure 10-50-4].

Keep the oil level between the low mark (Item 2) and high (Item 3) [Figure 10-50-4] on the dipstick.

For fluid level below the low mark (Item 2) [Figure 10-50-4], add SAE EP 80W90 to gearbox, recheck level with dipstick.

When fluid is at the correct level reinstall the plug/dipstick.

Transmission Fluid

48" Tiller

Figure 10-50-5

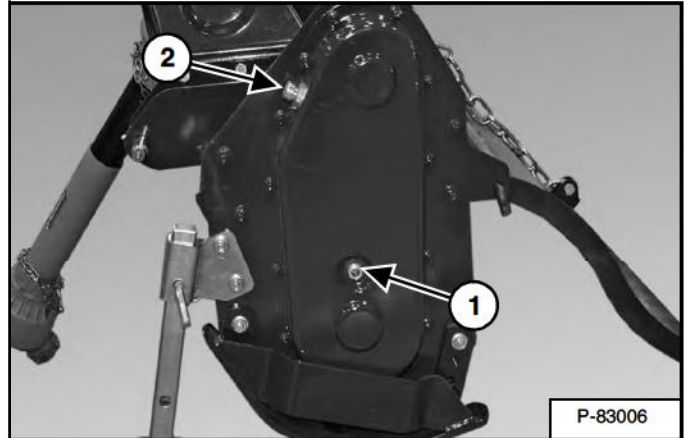

Place tiller on the ground so the transmission cover is level with the ground [Figure 10-50-5].

Look through the sight window on the plug (Item 1) to check fluid level. If the fluid is not visible through the window, remove the fill plug (Item 2) [Figure 10-50-5] and add SAE EP 80W90 until it is visible in the window.

Install and tighten the fill plug.

60" Tiller

Figure 10-50-6

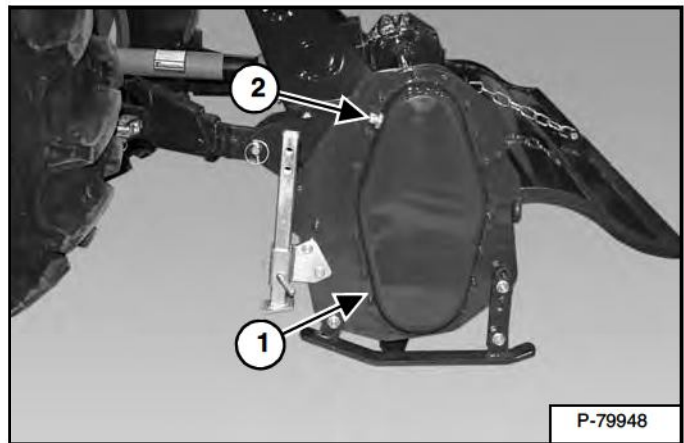

Place tiller on the ground so the transmission cover is level with the ground [Figure 10-50-6].

Remove the check plug (Item 1) to check fluid level. If the fluid does not come out of the check plug hole, remove the fill plug (Item 2) [Figure 10-50-6] and add SAE EP 80W90 until it comes out check plug hole.

Install and tighten the check and fill plugs.



Suggest:

If the above button click is invalid.

Please download this document

first, and then click the above link

to download the complete manual.

Thank you so much for reading

REGULAR MAINTENANCE ITEMS (CONT'D)

Transmission Fluid (Cont'd)

74" Tiller

Figure 10-50-7

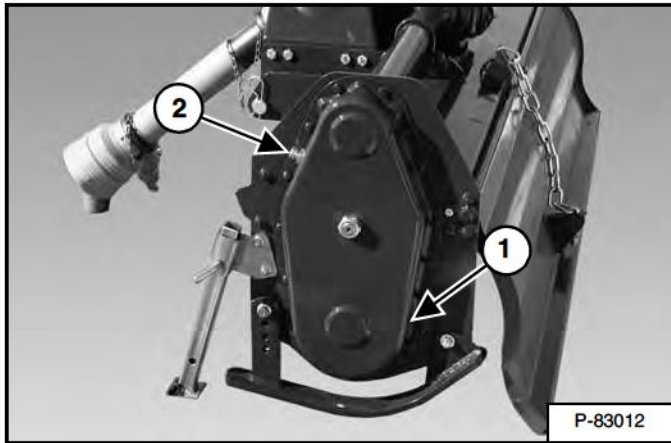

Place tiller on the ground so the transmission cover is level with the ground [Figure 10-50-7].

Remove the check plug (Item 1) to check fluid level. If the fluid does not come out of the check plug hole, remove the fill plug (Item 2) [Figure 10-50-7] and add SAE EP 80W90 until it comes out check plug hole.

Install and tighten the check and fill plugs.

Cleaning The Three-Point Tiller

WARNING

AVOID INJURY OR DEATH

Wear safety glasses to prevent eye injury when any of the following conditions exist:

- **When fluids are under pressure.**
- **Flying debris or loose material is present.**
- **Engine is running.**
- **Tools are being used.**

W-2019-0907

Stop the machine and implement on a flat level surface. Engage the parking brake. Disengage the rear-PTO and place all controls in neutral. Stop the engine, unfasten the seat belt, remove the key and exit the compact tractor.

Disconnect the PTO driveline.

Use water or air pressure to clean debris from the three-point tiller.

Use care when removing any obstructions that are wrapped around tines and driveline.

Dealer Copy -- Not for Resale

<https://www.ebooklibonline.com>

Hello dear friend!

Thank you very much for reading.

Enter the link into your browser.

The full manual is available for immediate download.

<https://www.ebooklibonline.com>