

CX800B
Crawler Excavator

SERVICE MANUAL

Part number 48020292

English

June 2016

© 2016 CNH Industrial Italia S.p.A. All Rights Reserved.

CASE
CONSTRUCTION



SERVICE MANUAL

CX800B CX800B RTC MASS EXC

Contents

INTRODUCTION

Machine completion and equipment.....	05
[05.200] Product shipment	05.1
Engine.....	10
[10.501] Exhaust Gas Recirculation (EGR) exhaust treatment.....	10.1
[10.001] Engine and crankcase	10.2
[10.102] Pan and covers	10.3
[10.106] Valve drive and gears	10.4
[10.101] Cylinder heads	10.5
[10.105] Connecting rods and pistons.....	10.6
[10.103] Crankshaft and flywheel.....	10.7
[10.216] Fuel tanks	10.8
[10.206] Fuel filters	10.9
[10.218] Fuel injection system.....	10.10
[10.202] Air cleaners and lines	10.11
[10.250] Turbocharger and lines.....	10.12
[10.254] Intake and exhaust manifolds and muffler	10.13
[10.400] Engine cooling system	10.14
[10.414] Fan and drive	10.15
[10.310] Aftercooler.....	10.16
[10.304] Engine lubrication system.....	10.17
[10.408] Oil cooler and lines.....	10.18
Hydraulic systems.....	35
[35.000] Hydraulic systems.....	35.1
[35.300] Reservoir, cooler, and filters.....	35.2
[35.104] Fixed displacement pump.....	35.3

<https://www.ebooklibonline.com>

Hello dear friend!

Thank you very much for reading.

Enter the link into your browser.

The full manual is available for immediate download.

<https://www.ebooklibonline.com>

[35.106] Variable displacement pump	35.4
[35.102] Pump control valves.....	35.5
[35.359] Main control valve	35.6
[35.357] Pilot system	35.7
[35.752] Hydraulic fan drive cooling system.....	35.8
[35.355] Hydraulic hand control	35.9
[35.356] Hydraulic foot control.....	35.10
[35.352] Hydraulic swing system	35.11
[35.353] Hydraulic travel system	35.12
[35.354] Hydraulic central joint	35.13
[35.736] Boom hydraulic system	35.14
[35.737] Dipper hydraulic system.....	35.15
[35.738] Excavator and backhoe bucket hydraulic system.....	35.16
[35.360] Hammer and rotating bucket hydraulic system	35.17
Frames and ballasting	39
[39.140] Ballasts and supports	39.1
Tracks and track suspension.....	48
[48.130] Track frame and driving wheels.....	48.1
[48.100] Tracks	48.2
[48.134] Track tension units	48.3
[48.138] Track rollers	48.4
Cab climate control	50
[50.100] Heating.....	50.1
[50.200] Air conditioning.....	50.2
Electrical systems	55
[55.000] Electrical system	55.1
[55.100] Harnesses and connectors.....	55.2
[55.525] Cab engine controls.....	55.3

[55.015] Engine control system.....	55.4
[55.201] Engine starting system.....	55.5
[55.301] Alternator.....	55.6
[55.302] Battery.....	55.7
[55.202] Cold start aid.....	55.8
[55.011] Fuel tank system.....	55.9
[55.010] Fuel injection system.....	55.10
[55.014] Engine intake and exhaust system.....	55.11
[55.989] Exhaust Gas Recirculation (EGR) electrical system.....	55.12
[55.012] Engine cooling system.....	55.13
[55.013] Engine oil system.....	55.14
[55.640] Electronic modules.....	55.15
[55.512] Cab controls.....	55.16
[55.035] Remote control valve electric control.....	55.17
[55.036] Hydraulic system control.....	55.18
[55.051] Cab Heating, Ventilation, and Air-Conditioning (HVAC) controls.....	55.19
[55.050] Heating, Ventilation, and Air-Conditioning (HVAC) control system.....	55.20
[55.416] Swing control system.....	55.21
[55.417] Travel control system.....	55.22
[55.518] Wiper and washer system.....	55.23
[55.404] External lighting.....	55.24
[55.514] Cab lighting.....	55.25
[55.408] Warning indicators, alarms, and instruments.....	55.26
[55.992] Anti-theft system.....	55.27
[55.DTC] FAULT CODES.....	55.28
Booms, dippers, and buckets.....	84
[84.910] Boom.....	84.1
[84.912] Dipper arm.....	84.2
[84.100] Bucket.....	84.3

Platform, cab, bodywork, and decals	90
[90.150] Cab	90.1
[90.156] Cab windshield and windows	90.2
[90.120] Mechanically-adjusted operator seat	90.3
[90.100] Engine hood and panels	90.4



INTRODUCTION

Foreword - Important notice regarding equipment servicing

All repair and maintenance work listed in this manual must be carried out only by qualified dealership personnel, strictly complying with the instructions given, and using, whenever possible, the special tools.

Anyone who performs repair and maintenance operations without complying with the procedures provided herein shall be responsible for any subsequent damages.

The manufacturer and all the organizations of its distribution chain, including - without limitation - national, regional, or local dealers, reject any responsibility for damages caused by parts and/or components not approved by the manufacturer, including those used for the servicing or repair of the product manufactured or marketed by the manufacturer. In any case, no warranty is given or attributed on the product manufactured or marketed by the manufacturer in case of damages caused by parts and/or components not approved by the manufacturer.

The manufacturer reserves the right to make improvements in design and changes in specifications at any time without notice and without incurring any obligation to install them on units previously sold. Specifications, descriptions, and illustrative material herein are as accurate as known at time of publication but are subject to change without notice.

In case of questions, refer to your CASE CONSTRUCTION Sales and Service Networks.

Safety rules

Personal safety



This is the safety alert symbol. It is used to alert you to potential personal injury hazards. Obey all safety messages that follow this symbol to avoid possible death or injury.

Throughout this manual you will find the signal words DANGER, WARNING, and CAUTION followed by special instructions. These precautions are intended for the personal safety of you and those working with you.

Read and understand all the safety messages in this manual before you operate or service the machine.

 DANGER indicates a hazardous situation that, if not avoided, will result in death or serious injury.

 WARNING indicates a hazardous situation that, if not avoided, could result in death or serious injury.

 CAUTION indicates a hazardous situation that, if not avoided, could result in minor or moderate injury.

FAILURE TO FOLLOW DANGER, WARNING, AND CAUTION MESSAGES COULD RESULT IN DEATH OR SERIOUS INJURY.

Machine safety

NOTICE: Notice indicates a situation that, if not avoided, could result in machine or property damage.

Throughout this manual you will find the signal word Notice followed by special instructions to prevent machine or property damage. The word Notice is used to address practices not related to personal safety.

Information

NOTE: Note indicates additional information that clarifies steps, procedures, or other information in this manual.

Throughout this manual you will find the word Note followed by additional information about a step, procedure, or other information in the manual. The word Note is not intended to address personal safety or property damage.

Safety rules - General information

Cleaning

Clean the metal parts with cleaning solution that meets the standard and steam cleaning. (except for bearings)

After cleaning, dry well, and inject oil in all parts.

Also inject oil into the bearings after drying.

Inspection

When disassembling parts, check all the parts.

If there are any worn or damaged parts, replace them.

Inspect carefully to prevent initial breakdowns.

Bearing

Replace any loose bearings.

Air dry bearings before installing them.

Needle bearing

When inserting needle bearings, be very careful not to damage them.

Apply grease to the section where the needle bearing will be inserted.

Gear

Check that there is no wear and no damage.

Oil seal, O-ring, gasket

Always install new oil seals, O-rings, and gaskets.

Apply grease to sections where oil seals and O-rings will be inserted.

Shaft

Check that there is no wear and no damage.

Check the bearings and check for damaged oil seals on the shaft.

Service parts

Install CASE CONSTRUCTION genuine service parts.

When placing an order, check the parts catalog. It contains the CASE CONSTRUCTION genuine part numbers.

Any breakdowns arising from the installation of non-genuine parts are not covered by the warranty.

Lubricants (fuel, hydraulic oil)

Use the oil from the specified company or specified in the operator's manual or service Manual.

Any breakdowns arising from any fuel or hydraulic oil other than those specified are not covered by the warranty.



SERVICE MANUAL

Engine

CX800B CX800B RTC MASS EXC

Exhaust Gas Recirculation (EGR) exhaust treatment - Component identification

EGR

The EGR system recirculates part of the exhaust gas back into the intake manifold, which results in reduced nitrogen oxide emissions. Higher operability and emission reduction are both realized by controlling the EGR system. A control current from the ECM operates a motor to control the lift amount of the EGR valve. In addition, the EGR position sensor is used for detection of the actual valve lift amount and for precision control of the EGR amount.

The EGR is activated when the specified conditions of engine speed, engine coolant temperature, intake air temperature, and barometric pressure are met. Then, the valve opening position is calculated based on the engine speed and desired fuel injection quantity. The motor drive duty is determined from this valve opening position, and the valve is driven according to the motor drive duty. Further, the EGR system is also equipped with a check valve to prevent the EGR from flowing in the opposite direction to increase the EGR amount.

Engine - Exhaust Gas Recirculation (EGR) exhaust treatment

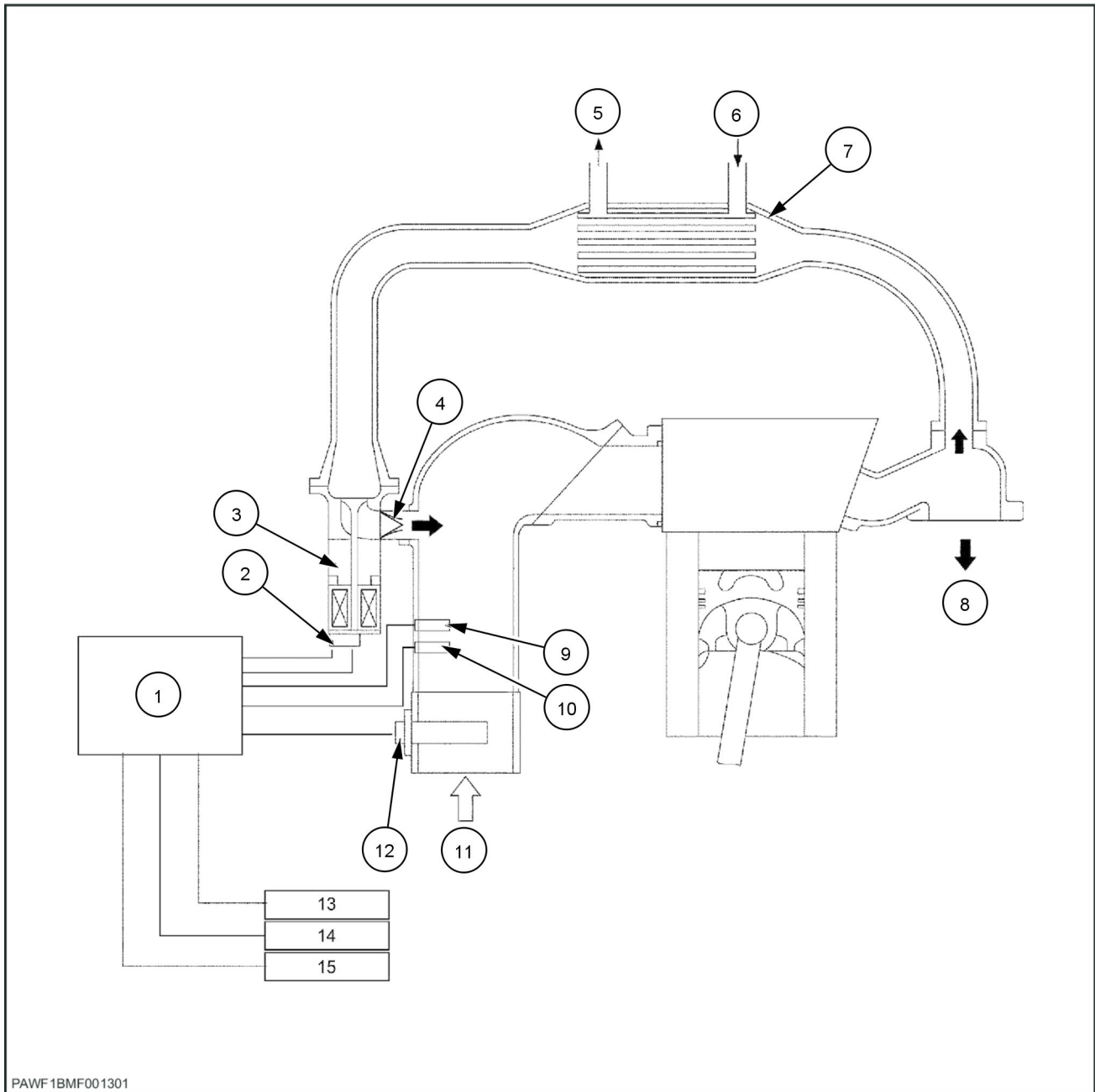

- | | |
|------------------------|---------------------------------------|
| 1. ECM | 9. Boost temperature sensor |
| 2. EGR position sensor | 10. Boost pressure sensor |
| 3. EGR valve | 11. Intake direction |
| 4. Reed valve | 12. Intake air temperature sensor |
| 5. Coolant outlet | 13. Engine speed |
| 6. Coolant inlet | 14. Engine coolant temperature sensor |
| 7. EGR cooler | 15. Barometric pressure sensor |
| 8. Exhaust direction | |

Exhaust Gas Recirculation (EGR) valve - Remove

Battery ground cable disconnect

1. Disengage the battery ground cable from the battery.

NOTICE: Do not disconnect the battery cable for **1 min** after turning **OFF** the ignition switch.

Coolant drain

⚠ WARNING

Burn hazard!

Hot coolant can spray and scald if you remove the radiator or deaeration tank cap while the system is hot. To remove the cap: allow the system to cool, turn the cap to the first notch, and wait for all pressure to release. Remove the cap only after all pressure has released. Failure to comply could result in death or serious injury.

W0367A

1. Drain coolant from the radiator.

NOTICE: After draining the coolant, tighten the drain plug (1).

2. Drain the coolant from the engine assembly.

NOTE: Loosen the drain plug (1) on the cylinder block side.

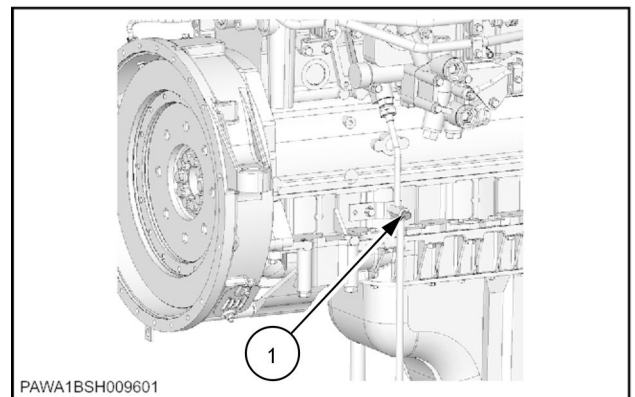

PAWA1BSH009601 1

Engine harness disconnect

1. Disconnect the engine harness from the engine.

NOTE: Disconnect each connector.

Ventilation hose disconnect

1. Disconnect the ventilation hose from the cylinder head cover.

EGR cooler water pipe removal

1. Remove the clip from the EGR cooler water pipe (1).
2. Remove the EGR cooler water pipe (1) from the water pump (2).
3. Remove the EGR cooler water pipe (1) from the thermostat housing (3).

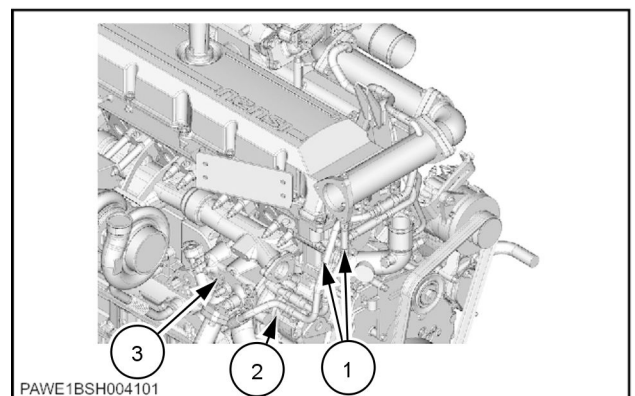

PAWE1BSH004101 2

EGR pipe removal

1. Remove the air leak pipe (2) from the EGR cooler (3).

NOTE: The existence or nonexistence of the equipment varies depending on the machine.

2. Remove EGR pipe A (1) from EGR cooler A (4).

NOTE: Remove as a set with the air leak pipe (2) bracket.

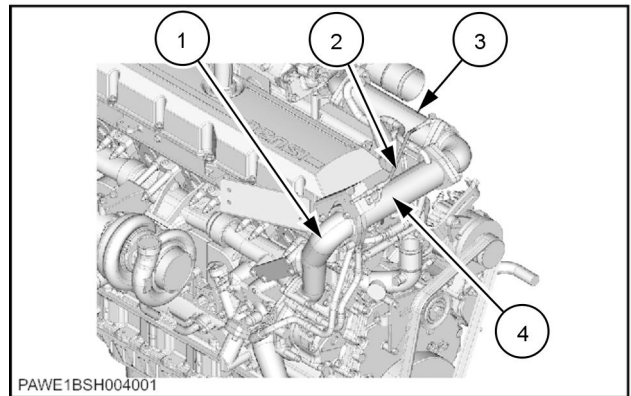

PAWE1BSH004001

PAWE1BSH004001 3

EGR cooler removal

1. Remove EGR cooler A (3) from EGR pipe B (2).
2. Remove EGR cooler B (1) from the EGR cooler duct.
3. Remove the EGR cooler duct from the inlet manifold.
4. Remove the EGR cooler bracket from the cylinder head.

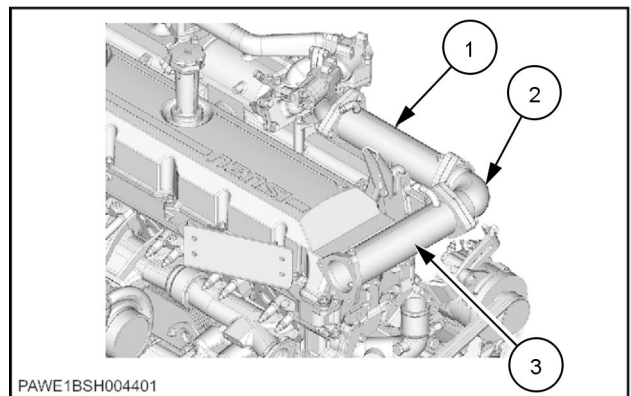

PAWE1BSH004401

PAWE1BSH004401 4

EGR valve removal

1. Remove EGR valve duct A (2) from EGR valve duct C (5).
2. Remove EGR valve duct B (3) from EGR valve duct D (4).
3. Remove the EGR valve (1) from the EGR cooler duct (6).

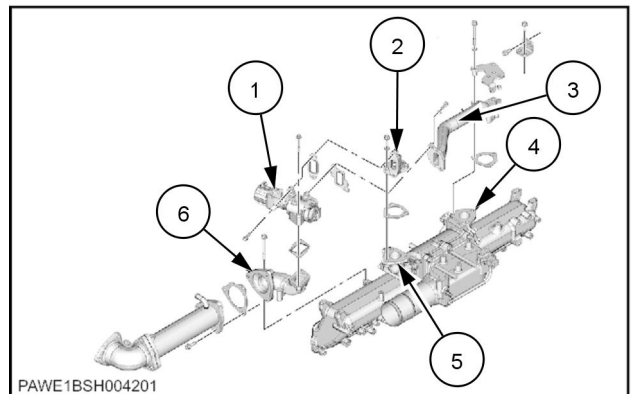

PAWE1BSH004201

PAWE1BSH004201 5

Reed valve removal

1. Remove EGR valve duct C **(1)** from the inlet manifold.
2. Remove EGR valve duct D **(4)** from the inlet manifold.
3. Remove the reed valve **(2) (3)** from the inlet manifold **(5)**.

NOTICE: If the reed valve is dropped, do not reuse it.

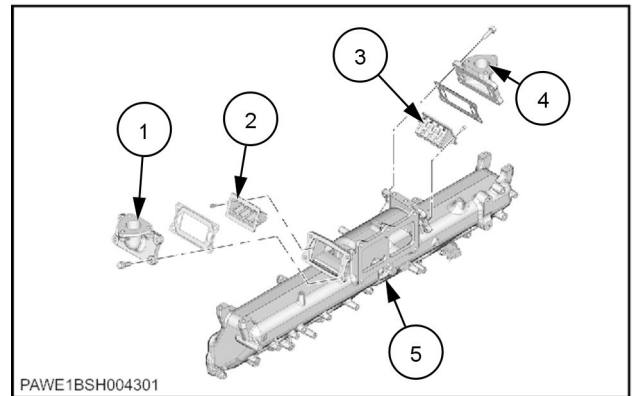

PAWE1BSH004301

PAWE1BSH004301 6

Exhaust Gas Recirculation (EGR) valve - Install

Reed valve installation

1. Install the reed valve (2) (3) to the inlet manifold (5).

Tightening torque: **10 N·m (7.38 lb ft)**

NOTICE: If the reed valve is dropped, do not reuse it.

2. Install EGR valve duct D (4) to the inlet manifold (5).

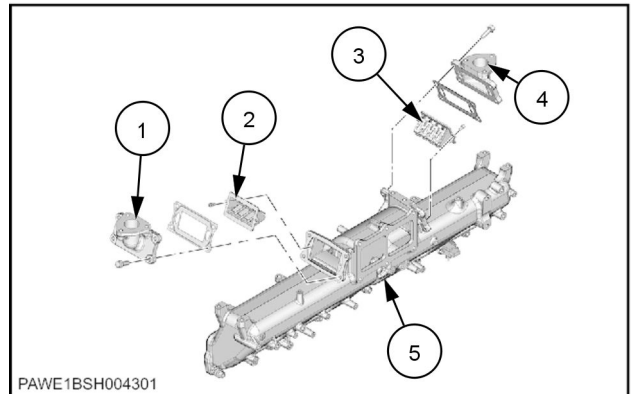

PAWE1BSH004301 1

3. Install EGR valve duct C (1) to the inlet manifold (5).

Tightening torque: **39 N·m (28.76 lb ft)**

EGR valve installation

1. Temporarily tighten the EGR valve (1) to the EGR cooler duct (6).

2. Temporarily tighten EGR duct A (2) to reed valve duct A (5).

3. Temporarily tighten EGR duct B (3) to reed valve duct B (4).

NOTICE: For the EGR duct, EGR cooler, etc., lightly tighten the bolts to the position where each contact surface makes contact. After positioning them so there are no gaps on the seal surface, tighten again.

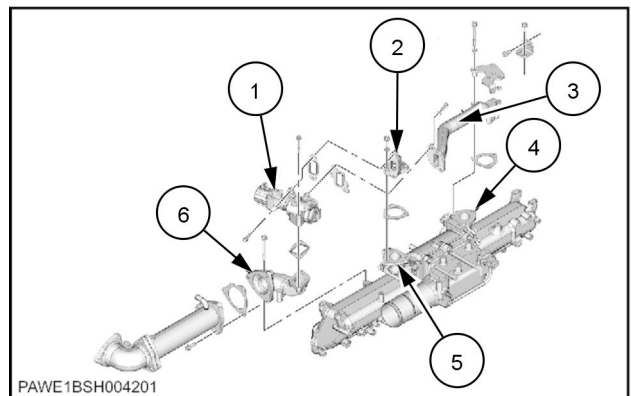

PAWE1BSH004201 2

4. Final tighten the EGR valve to the EGR cooler duct.

Tightening torque: **39 N·m (28.76 lb ft)**

5. Final tighten EGR duct A to the EGR valve.

NOTE: Referring to the diagram, final tighten in numerical order.

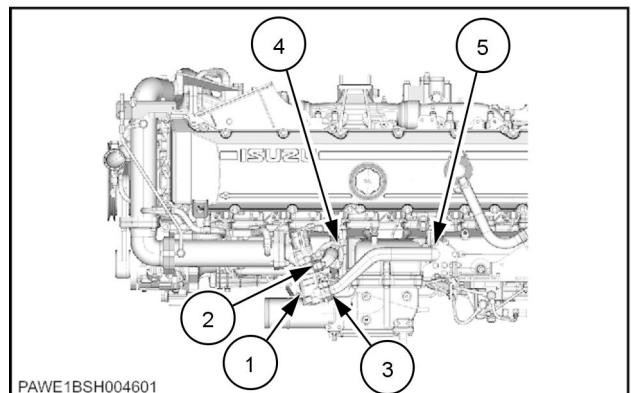

PAWE1BSH004601 3

EGR cooler installation

1. Temporarily tighten the EGR cooler bracket to the cylinder head.
2. Temporarily tighten the EGR cooler duct to the inlet manifold.

NOTE: Install the EGR cooler gasket to EGR cooler B.

3. Temporarily tighten EGR cooler B to the EGR cooler duct.

NOTICE: For the EGR duct, EGR cooler, etc., lightly tighten the bolts to the position where each contact surface makes contact. After positioning them so there are no gaps on the seal surface, tighten again.

4. Final tighten EGR cooler B to the EGR cooler duct.
5. Final tighten the EGR cooler bracket to the cylinder head.

Tightening torque: **118 N·m (87.03 lb ft)**.

6. Final tighten EGR cooler B to the EGR cooler bracket.
7. Final tighten the EGR cooler duct to the inlet manifold.

NOTE: Referring to the diagram, final tighten in numerical order.

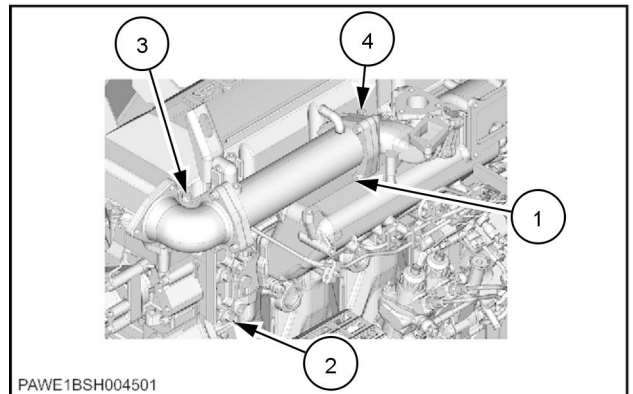

PAWE1BSH004501 4

EGR pipe installation

1. Install EGR pipe A (1) to EGR cooler A (4).

Tightening torque: **38 N·m (28.03 lb ft)**.

2. Install the air leak pipe to the EGR cooler.

NOTE: Install as a set with the air leak pipe (2) bracket. The existence or nonexistence of the equipment varies depending on the machine.

Tightening torque: **22 N·m (16.23 lb ft)**.

3. EGR cooler B

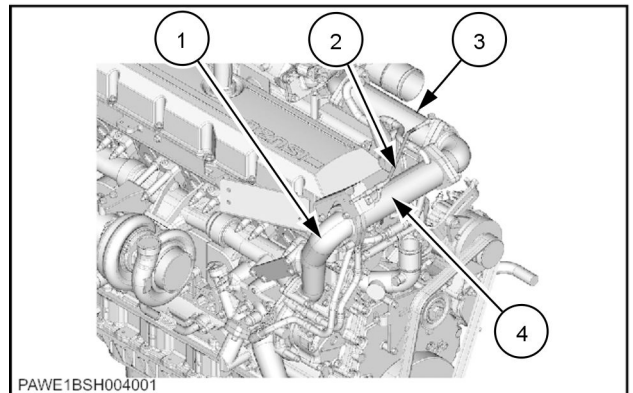

PAWE1BSH004001 5

NOTE: Referring to the diagram, final tighten in numerical order.

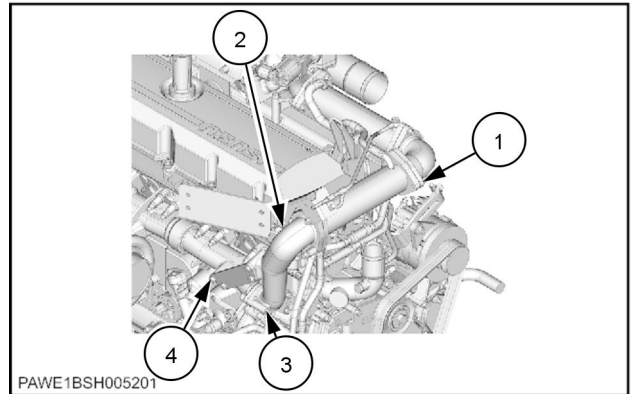

PAWE1BSH005201 6

EGR cooler water pipe installation

1. Install the EGR cooler water pipe (1) to the thermostat housing (3).
2. Install the EGR cooler water pipe (1) to the water pump (2).
3. Install the clip to the EGR cooler water pipe (1).

Tightening torque: **25 N·m (18.44 lb ft)**.

NOTICE: Take note of the joint from turning when installing the clip.

Install the water hose clip horizontally.

When inserting the rubber hose, apply soapy water, etc. to the inner surface of the hose.

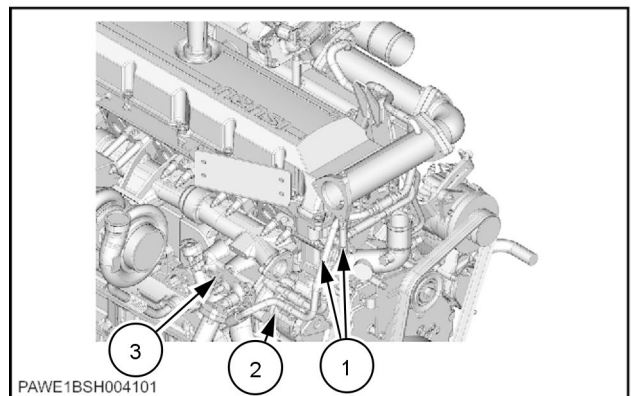

PAWE1BSH004101 7

Ventilation hose connect

1. Connect the ventilation hose to the cylinder head cover.

Engine harness connect

1. Connect the engine harness to the engine.

NOTE: Connect each connector.

Coolant filling

NOTICE: Change the coolant when the engine is cool.

1. Loosen the plug using the wrench.

NOTE: The specifications vary depending on the machine, so only remove if there is a plug.

2. Replenish the coolant with the radiator.

NOTE: Tighten the plug when the coolant has overflowed.

NOTICE: Be careful not to let coolant overflow splash on the exhaust system parts.

Coolant overflow should be wiped off.

3. Tighten the plug **(1)** using the wrench.

Tightening torque: **27.5 N·m (20.28 lb ft)** Idle pulley lock nut

4. Replenish the coolant with the radiator.

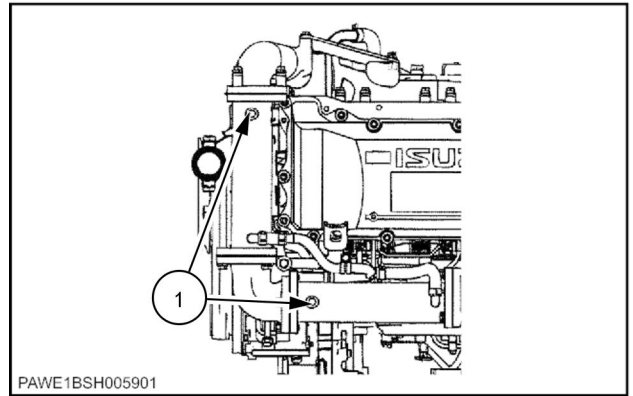

PAWE1BSH005901 8

Battery ground cable connect

1. Connect the battery ground cable to the battery.

Exhaust Gas Recirculation (EGR) cooler - Remove

Battery ground cable disconnect

1. Disconnect the battery ground cable from the battery.

NOTICE: Do not disconnect the battery cable for **1 min** after turning OFF the ignition switch.

Coolant drain

⚠ WARNING

Burn hazard!

Hot coolant can spray and scald if you remove the radiator or deaeration tank cap while the system is hot. To remove the cap: allow the system to cool, turn the cap to the first notch, and wait for all pressure to release. Remove the cap only after all pressure has released. Failure to comply could result in death or serious injury.

W0367A

1. Drain coolant from the radiator.

NOTICE: After draining the coolant, tighten the drain plug (1).

2. Drain the coolant from the engine assembly.

NOTE: Loosen the drain plug on the cylinder block side.

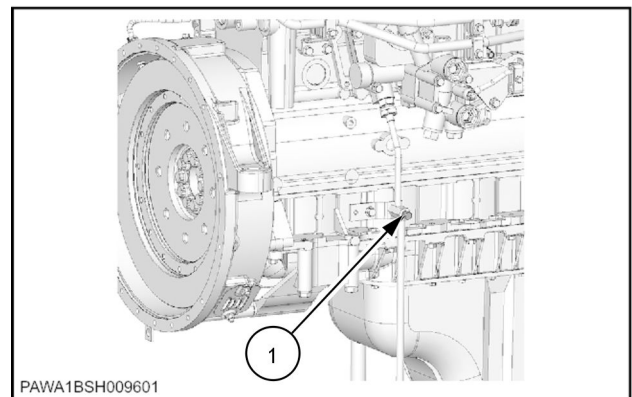

PAWA1BSH009601

PAWA1BSH009601 1

Engine harness disconnect

1. Disconnect the engine harness from the engine.

NOTE: Disconnect each connector.

Ventilation hose disconnect

1. Disconnect the ventilation hose from the cylinder head cover.

EGR pipe removal

1. Remove the air leak pipe (2) from the EGR cooler (3).

NOTE: The existence or nonexistence of the equipment varies depending on the machine.

2. Remove EGR pipe A (1) from EGR cooler A (4).

NOTE: Remove as a set with the air leak pipe bracket.

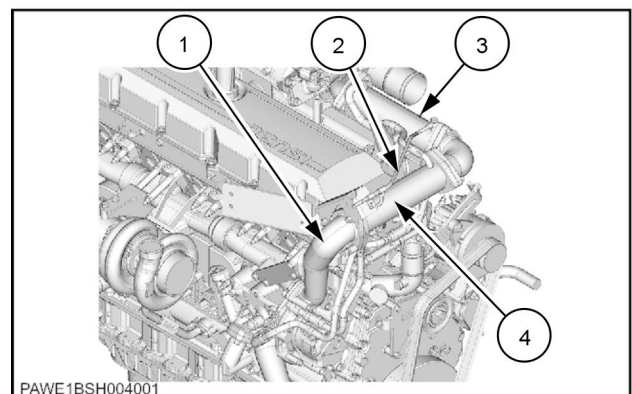

PAWE1BSH004001

PAWE1BSH004001 2

EGR cooler water pipe removal

1. Remove the clip from the EGR cooler water pipe (1).
2. Remove the EGR cooler water pipe (1) from the water pump (2).
3. Remove the EGR cooler water pipe (1) from the thermostat housing (3).

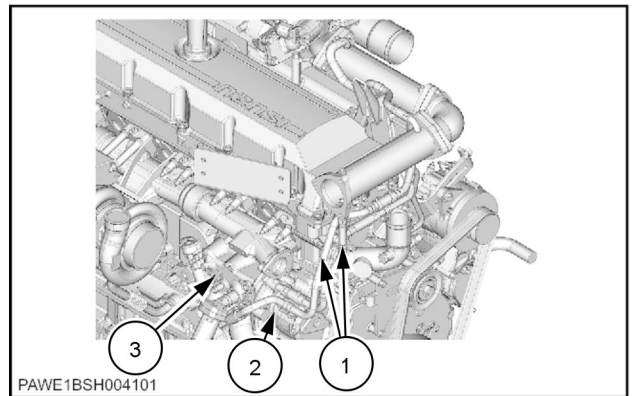

PAWE1BSH004101 3

EGR cooler removal

1. Remove EGR cooler A (3) from EGR pipe B (2).
2. Remove EGR cooler B (1) from the EGR cooler duct.
3. Remove the EGR cooler duct from the inlet manifold.
4. Remove the EGR cooler bracket from the cylinder head.

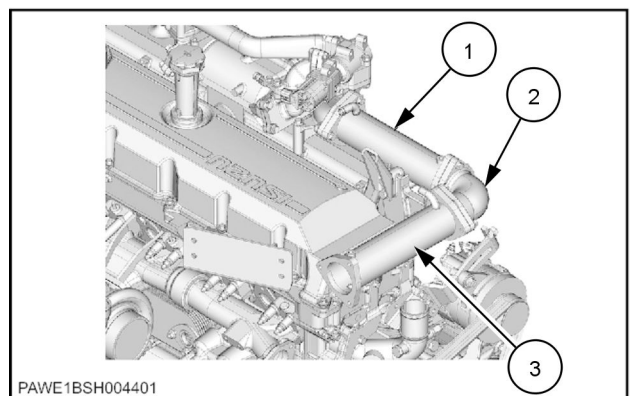

PAWE1BSH004401 4

Exhaust Gas Recirculation (EGR) cooler - Inspect

EGR cooler cleaning

WARNING

Flying debris!

Wear eye protection and protective clothing during the cleaning process. Clear the area of bystanders.

Failure to comply could result in death or serious injury.

W0364A

WARNING

Chemical hazard!

When handling fuel, lubricants, and other service chemicals, follow the manufacturer's instructions.

Wear Personal Protective Equipment (PPE) as instructed. Do not smoke or use open flame. Collect fluids in proper containers. Obey all local and environmental regulations when disposing of chemicals.

Failure to comply could result in death or serious injury.

W0371A

NOTICE: Clean the EGR cooler every **4500 h**.

1. Remove the EGR cooler from the engine.

NOTICE: Apply plugs to all the coolant passages of the removed EGR cooler.

2. Prepare the cleaning fluid.

NOTE: Use Oil-Clean for the cleaning fluid.

3. Prepare the container.

NOTE: Pour the Oil-Clean into the container.

4. Clean the EGR cooler using the cleaning fluid.

NOTE: Soak the EGR cooler in Oil-Clean and wait for **1 h**.

NOTE: Remove the Oil-Clean from the EGR cooler using a cleaner after the specified time has passed.

When dirt is not cleaned off, repeat the cleaning work.

5. Install the EGR cooler to the engine.

NOTICE: Before installing the EGR cooler, dry it completely.

Exhaust Gas Recirculation (EGR) cooler - Install

EGR cooler installation

1. Temporarily tighten the EGR cooler bracket to the cylinder head.
2. Temporarily tighten the EGR cooler duct to the inlet manifold.

NOTE: Install the EGR cooler gasket to EGR cooler B.

3. Temporarily tighten EGR cooler B to the EGR cooler duct.

NOTICE: For the EGR duct, EGR cooler, etc., lightly tighten the bolts to the position where each contact surface makes contact. After positioning them so there are no gaps on the seal surface, tighten again.

4. Final tighten EGR cooler B to the EGR cooler duct.
5. Final tighten the EGR cooler bracket to the cylinder head.

Tightening torque: **118 N·m (87.03 lb ft)**

6. Final tighten EGR cooler B to the EGR cooler bracket.
7. Final tighten the EGR cooler duct to the inlet manifold.

NOTE: Referring to the diagram, final tighten in numerical order.

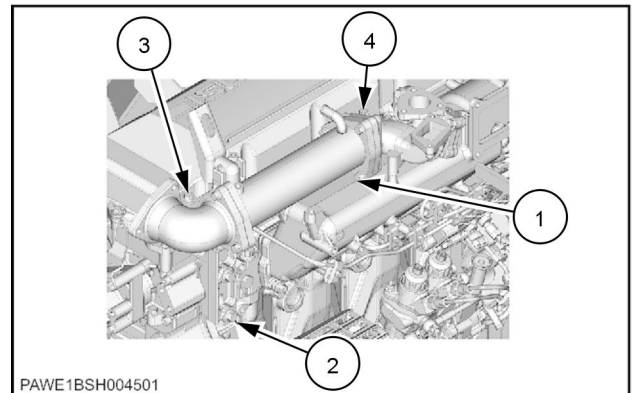

PAWE1BSH004501 1

EGR pipe installation

1. Install EGR pipe A (1) to EGR cooler A (4).

Tightening torque: **38 N·m (28.03 lb ft)**

2. Install the air leak pipe (2) to the EGR cooler (3).

NOTE: Install as a set with the air leak pipe (2) bracket.
The existence or nonexistence of the equipment varies depending on the machine.

Tightening torque: **22 N·m (16.23 lb ft)**

NOTE: Referring to the diagram, final tighten in numerical order.

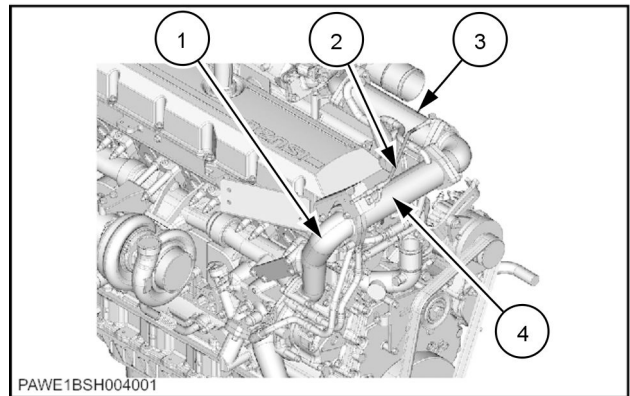

PAWE1BSH004001 2

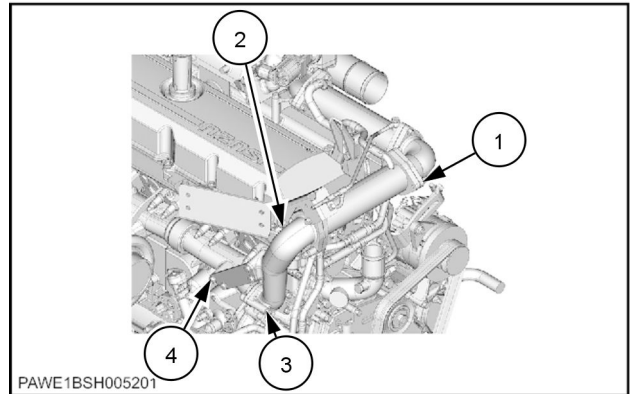

PAWE1BSH005201 3

EGR cooler water pipe installation

1. Install the EGR cooler water pipe (1) to the thermostat housing (3).

2. Install the EGR cooler water pipe (1) to the water pump (2).

3. Install the clip to the EGR cooler water pipe (1).

Tightening torque: **25 N·m (18.44 lb ft)**

NOTICE: Take note of the joint from turning when installing the clip.

Install the water hose clip horizontally.

When inserting the rubber hose, apply soapy water, etc. to the inner surface of the hose.

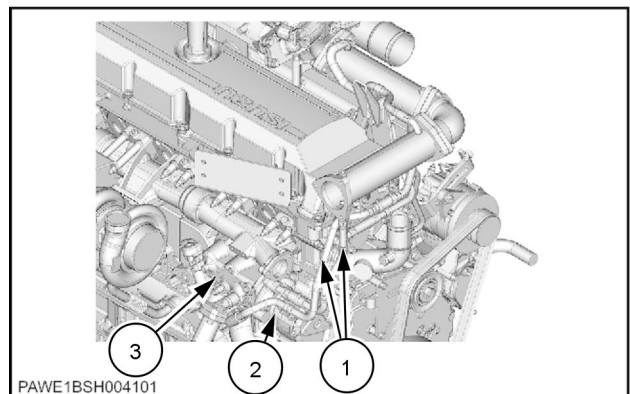

PAWE1BSH004101 4

Ventilation hose connect

1. Connect the ventilation hose to the cylinder head cover.

Engine harness connect

1. Connect the engine harness to the engine.

NOTE: Connect each connector.

Coolant filling

NOTICE: Change the coolant when the engine is cool.

1. Loosen the plug **(1)** using the wrench.

NOTE: The specifications vary depending on the machine, so only remove if there is a plug **(1)**.

2. Replenish the coolant with the radiator.

NOTE: Tighten the plug **(1)** when the coolant has overflowed.

NOTICE: Be careful not to let coolant overflow splash on the exhaust system parts.
Coolant overflow should be wiped off.

3. Tighten the plug using the wrench.

Tightening torque: **27.5 N·m (20.28 lb ft)**

4. Replenish the coolant with the radiator.

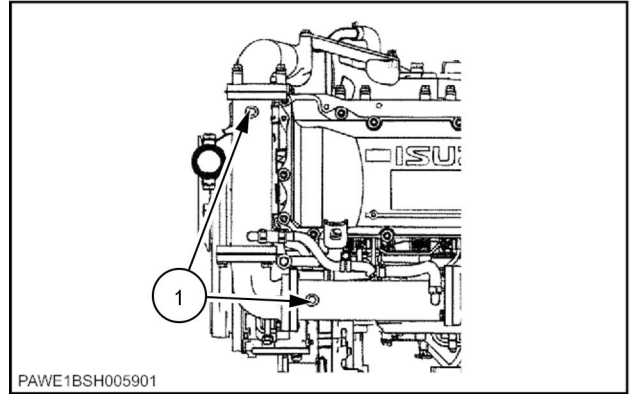

PAWE1BSH005901 5

Battery ground cable connect

1. Connect the battery ground cable to the battery.

Engine - Remove

1. Remove the engine hood. (For details, see Removal and Installation of Engine Hood **Radiator - Remove (10.400)**)
2. Remove the hydraulic pump. (For details, see Removal and Installation of Hydraulic Pump **Radiator - Remove (10.400)**)
3. Use a wrench [**19 mm**] to remove the 8 bolts (1) and the 8 washers (2), then remove the step (3).

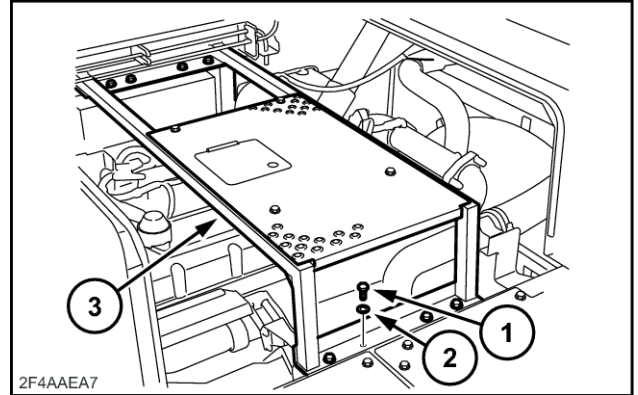

2F4AAEA7 1

4. Use a wrench [**19 mm**] to remove the 5 bolts (1), and then remove the under cover (2).

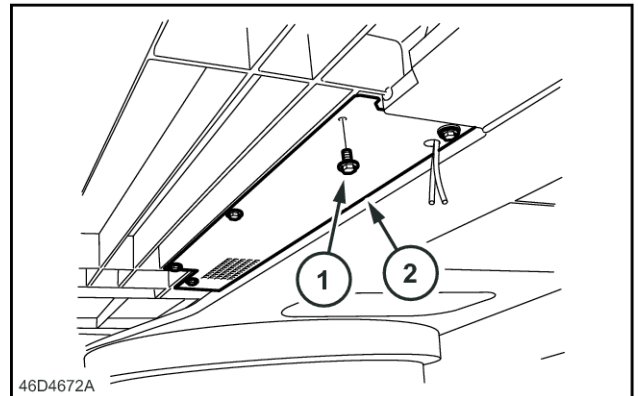

46D4672A 2

5. Use a wrench [**8 mm**] to loosen the hose band (1) on the radiator, and then remove the upper hose (2).
 - Before removing the radiator hoses, completely drain the coolant.
 - Use caps to cover the radiator and hoses to prevent the entry of water, dust or dirt.

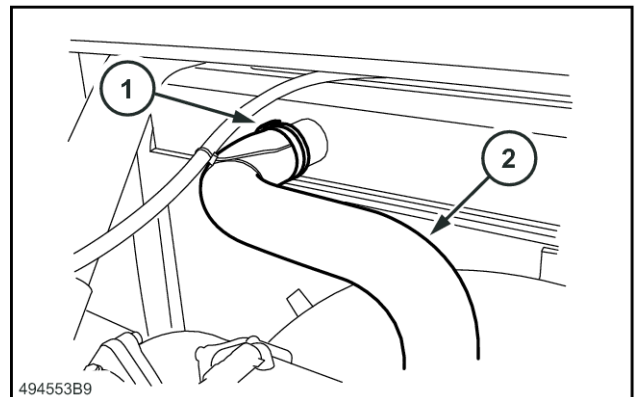

494553B9 3

6. Use a wrench [**8 mm**] to loosen the hose band (1) on the radiator, and then remove the lower hose (2).
- Use caps to cover the radiator and hoses to prevent the entry of water, dust or dirt.

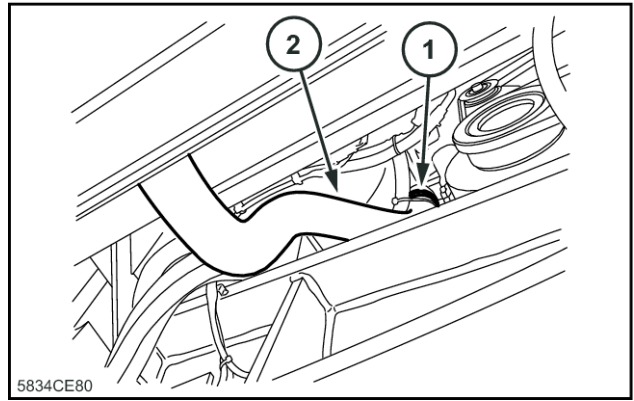

5834CE80 4

7. Use a wrench [**12 mm**] to remove the 2 line bolts (1), then remove the 2 lines (2) (3) from the compressor.
- Always remove the low-pressure side (suction side) line (2) first.
 - Attach caps or plugs to the compressor and lines to prevent any entry of water, dust or dirt.
 - The O-ring cannot be reused. Always replace them with new ones.

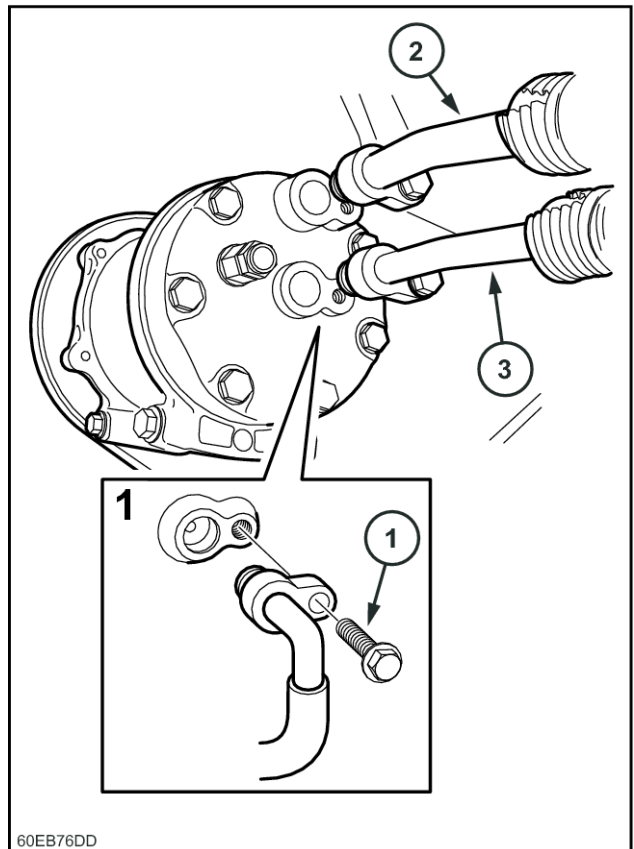

60EB76DD 5

8. Use a wrench [**8 mm**] to loosen the hose band (1) on the inter cooler, and then remove the hose (2).
- Use caps to cover the line and hose to prevent the entry of water, dust or dirt.

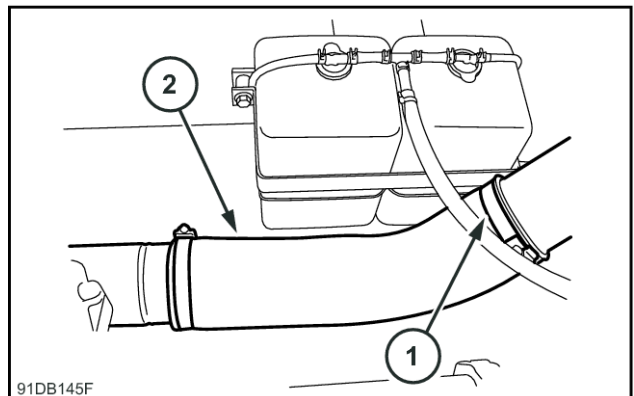

91DB145F 6

9. Use a wrench [**19 mm**] to remove the 11 bolts (3), then remove the under covers (1) (2).

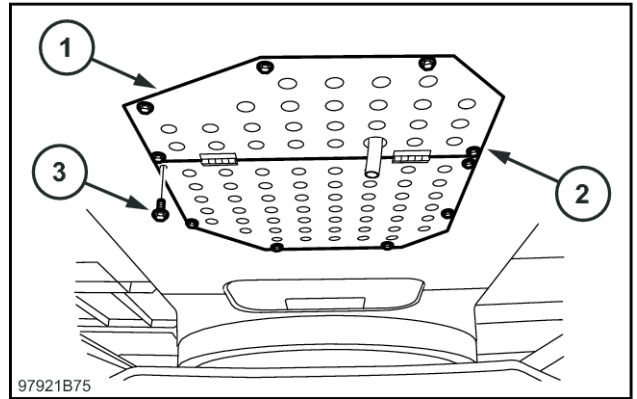

97921B75 7

10. Prepare the waste oil can (1).

- Drain the engine oil before removing the engine oil hose.

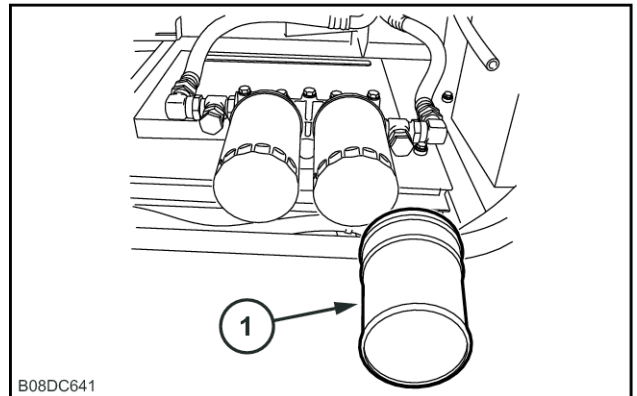

B08DC641 8

11. Use a wrench [**36 mm**] to remove the 2 engine oil remote hoses (1).

- Mark the engine and hoses so that the connectors match at the time of assembly.
- Attach caps or plugs to the engine and hoses to prevent any entry of water, dust or dirt.
- Clean the engine and hoses by spraying them with a parts cleaner to prevent scratches and prevent dirt from accumulating on the connectors.

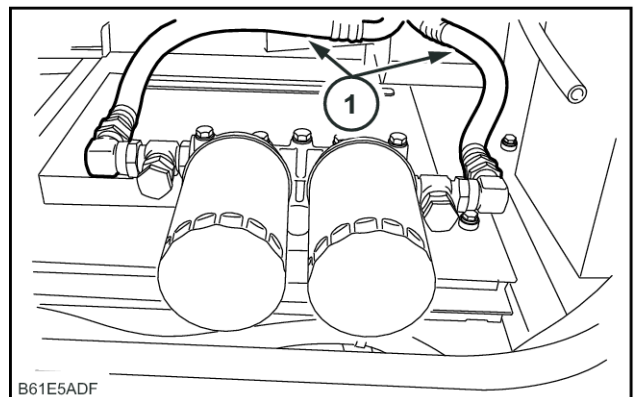

B61E5ADF 9

12. Use a wrench [**17 mm**] to remove the nut (1), then remove the battery cable (2) on the negative side.

- When removing the terminal and harness, secure them so that they do not interfere with the frame. Also, cover with a rubber cap to protect against sparks.

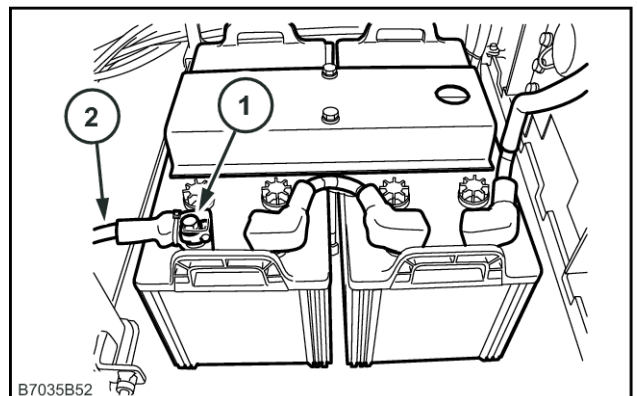

B7035B52 10

13. Use a wrench [**8 mm**] to remove the 1 nuts (1), then remove the wiring (2) from the starter motor.

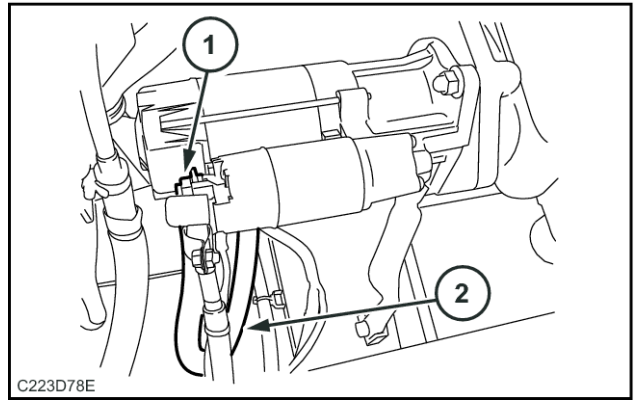

C223D78E 11

14. Use a wrench [**14 mm**] to remove the 2 nuts (1), then remove the wiring (2) from the starter motor.

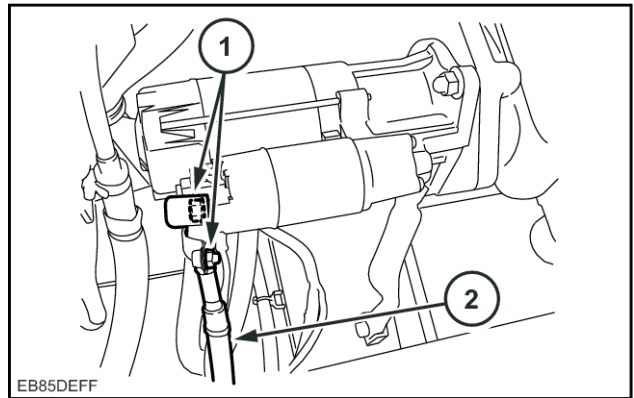

EB85DEFF 12

15. Close the fuel line (1) stop valve (2).

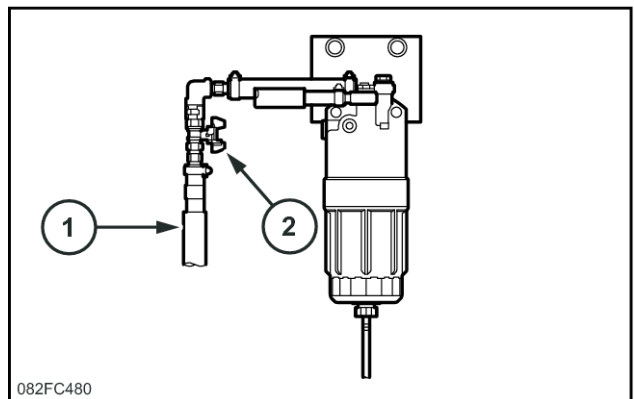

082FC480 13

16. Remove the hose bands (1), then remove the 2 fuel hoses (2).
- Attach caps or plugs to the engine and hoses to prevent any entry of water, dust or dirt.

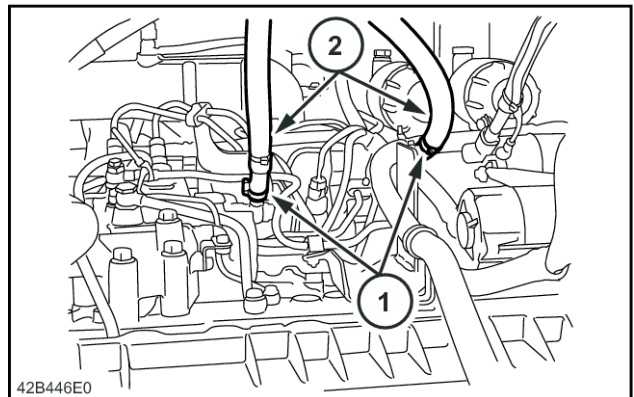

42B446E0 14

17. Use a wrench [**13 mm**] to remove the 4 bolts (1), and then remove the box cover (2).

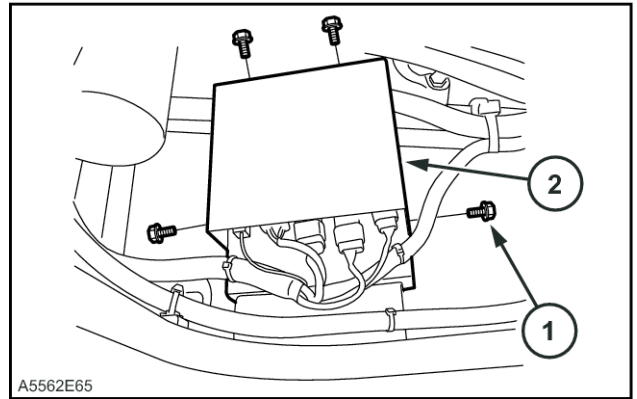

A5562E65 15

18. Remove the connectors (1) in the box.
- Wrap the removed connectors in plastic after tying them together.

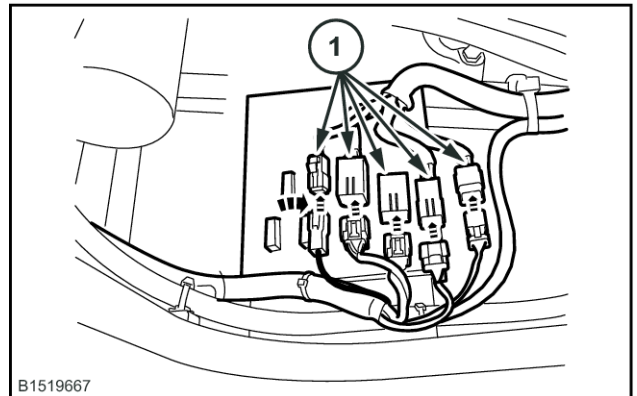

B1519667 16

19. Use a wrench [**7 mm**] to loosen the hose bands (1), then remove the 2 heater hoses (2).
- Attach caps or plugs to the engine and hoses to prevent any entry of water, dust or dirt.

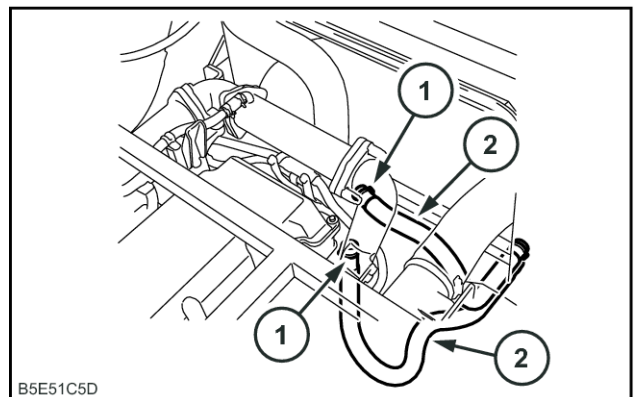

B5E51C5D 17

20. Use a wrench [**8 mm**] to loosen the hose band (1), and then remove the air hose (2).
- Use caps to cover the lines and hoses to prevent any entry of water, dust or dirt.

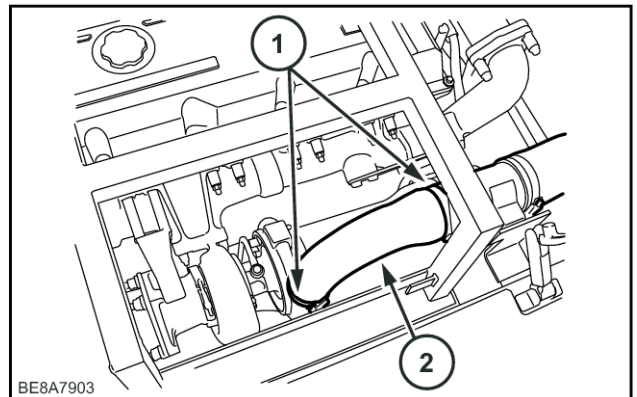

BE8A7903 18

21. Use a wrench [**7 mm**] to loosen the hose band **(1)**, then remove the air hose **(2)**.
 - Use caps to cover the lines and hoses to prevent any entry of water, dust or dirt.
22. Remove the connector **(1)** from the alternator.

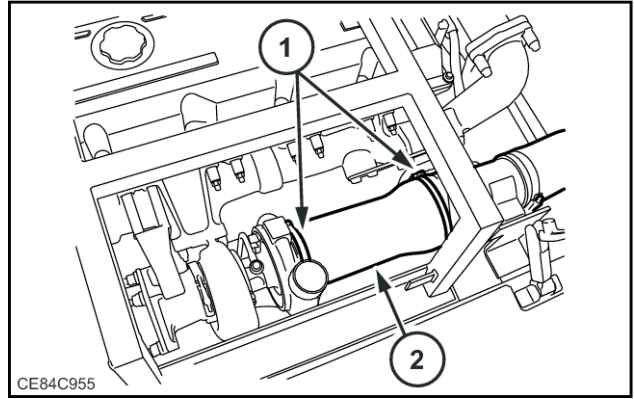

CE84C955 19

23. Use a wrench [**10 mm**] to remove the bolt **(2)** and nut **(3)**, then remove the wiring **(4)** from the alternator.

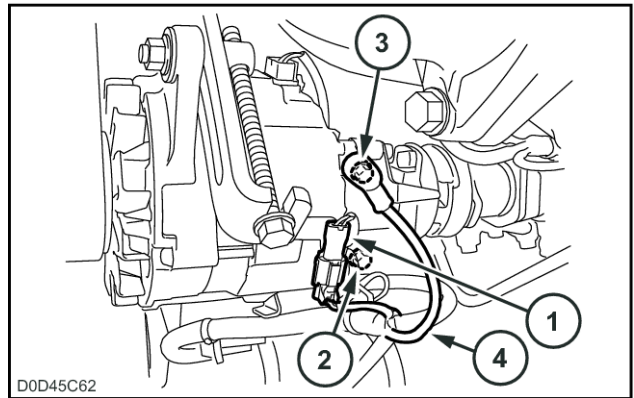

D0D45C62 20

24. Install the 2 shackles **(1)**, then use the wire rope **(2)** and liftcrane to secure the engine main unit.

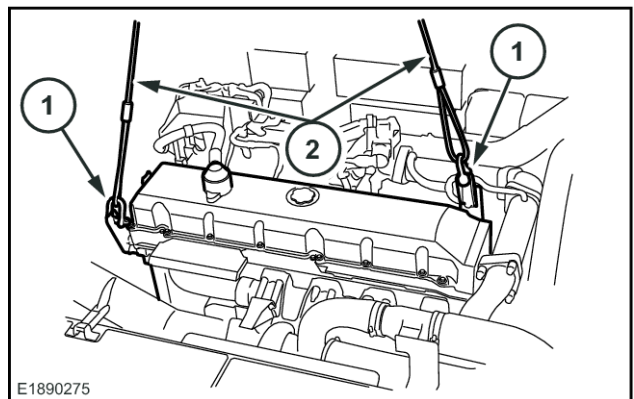

E1890275 21



Suggest:

If the above button click is invalid.

Please download this document

first, and then click the above link

to download the complete manual.

Thank you so much for reading

25. Use a box wrench [**36 mm**] to remove the 4 bolts (1) and 4 nuts (2) from the mount.
- Remove from the right side (feed pump side).

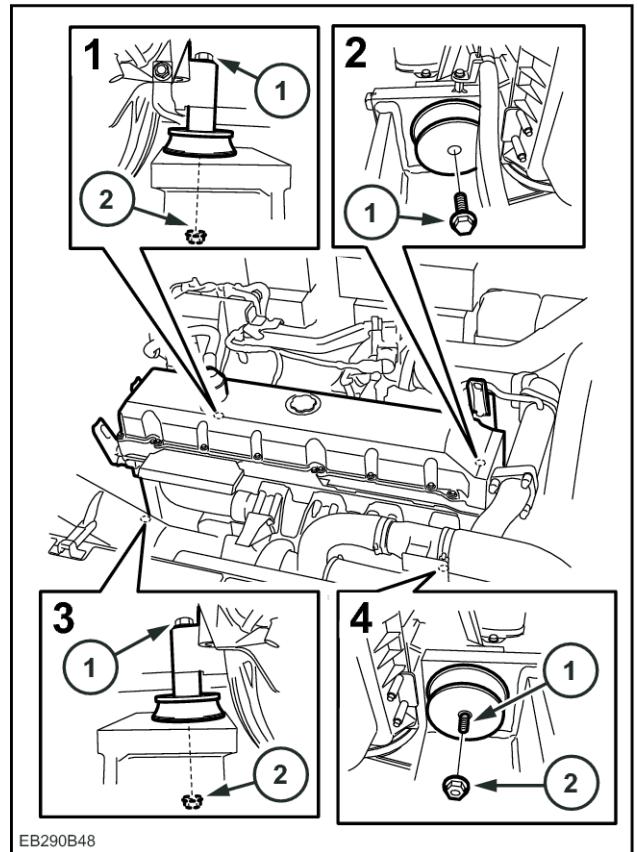

EB290B48 22

26. Use the wire rope (1) and liftcrane to lift the engine main unit.
27. Thoroughly check that the location is safe before lowering the engine on wood planks, etc.

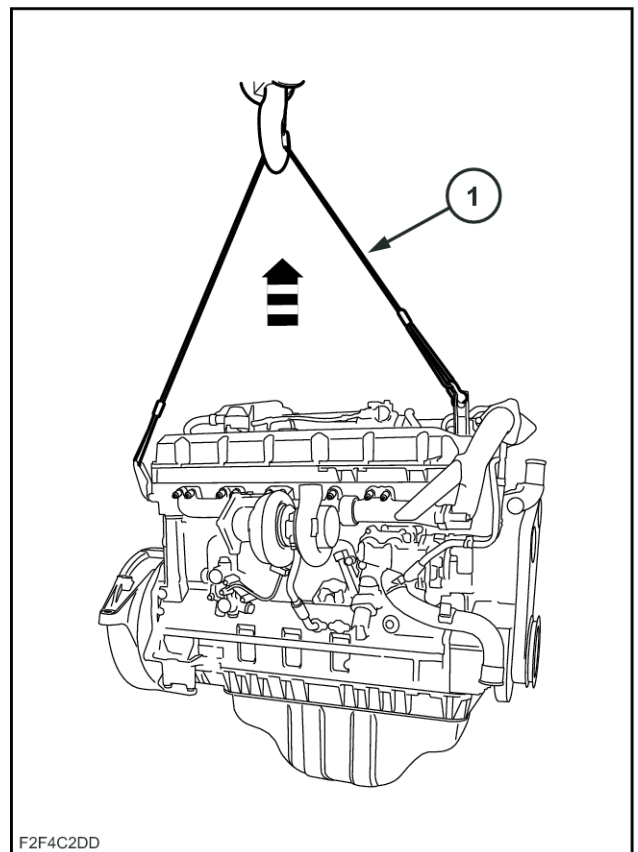

F2F4C2DD 23

<https://www.ebooklibonline.com>

Hello dear friend!

Thank you very much for reading.

Enter the link into your browser.

The full manual is available for immediate download.

<https://www.ebooklibonline.com>