

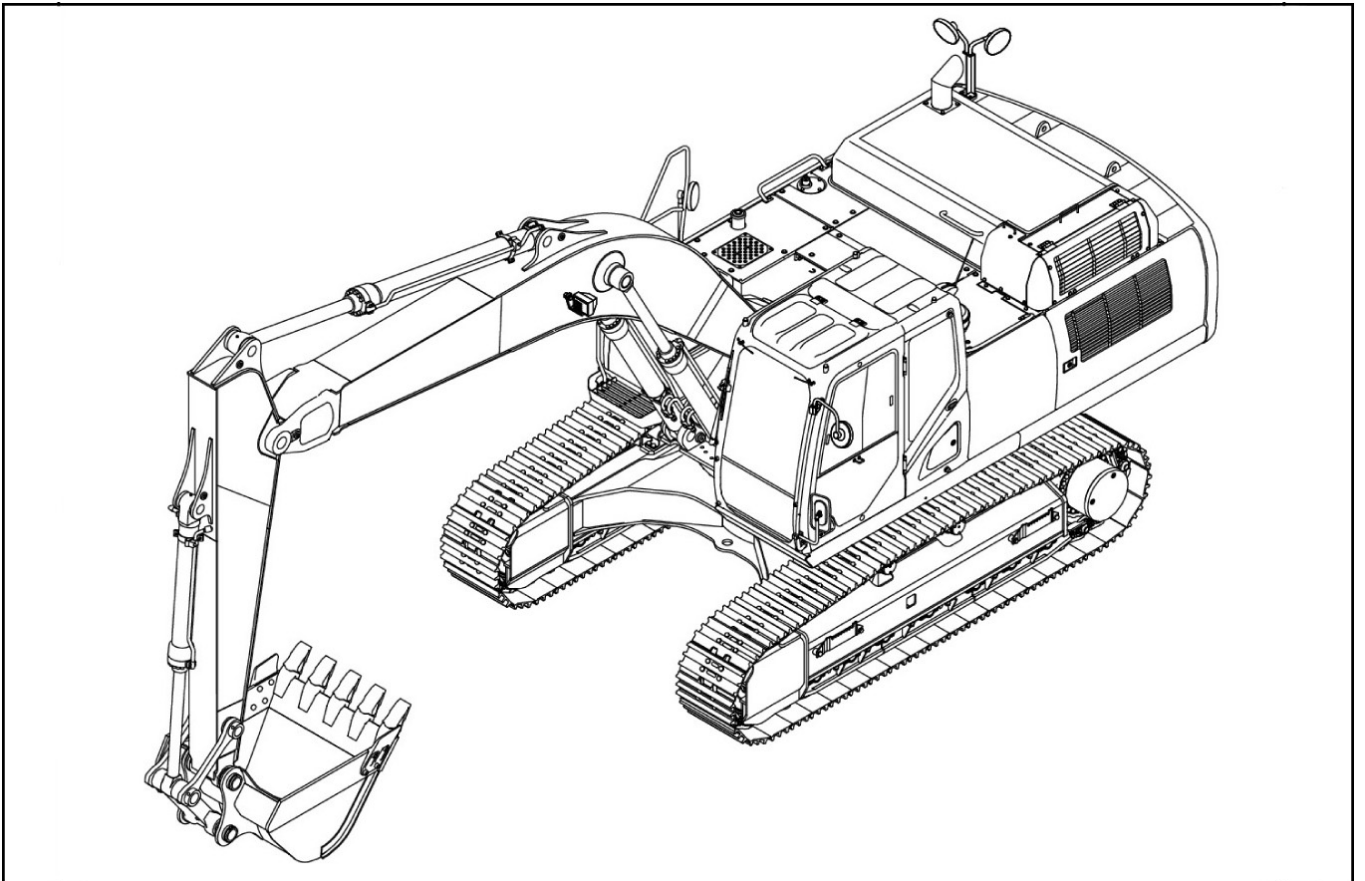

# SERVICE MANUAL

**Lep 84402827B EN**



## **CX350C - CX370C Tier 4 Crawler Excavator**

# CRAWLER EXCAVATORS CX350C - CX370C TIER 4 SERVICE MANUAL

## TABLE OF CONTENTS

DIVISION/SECTION	SECTION N°
<b>1 GENERAL INFORMATION</b>	
Safety, general information and standard torque data .....	1001
Specifications .....	1002A
Main Equipment Table .....	1002B
Main Unit Weight .....	1002C
Maintenance Standards .....	1002D
Bolt Size and Torque Table .....	1002E
Overall View .....	1002F
List of Special Tools .....	1003
Fluid and Lubricants .....	1004
Conversion Table .....	1005
Abbreviations .....	1900
<b>2 ENGINE</b>	
Removal and Installation of Engine Assembly .....	2000
Removal and Installation of the Fuel Cooler Engine Inter-Cooler Radiator and Oil Cooler .....	2001
Removal and Installation of Turbo Charger .....	2004
Removal and Installation of EGR Cooler and EGR Valve .....	2005
Removal and Installation of Engine Hood .....	2006
Removal and Installation of Muffler .....	2007
Primary specifications .....	2401
Removal and Installation of Cylinder Head .....	2415
Removal and Installation of Cylinder Block .....	2425
Lubrication System .....	2445
Cooling System .....	2455
Removal and Installation of Exhaust Manifold .....	2465
Disassembly, Removal and Installation of DPD Assembly .....	2470
<b>3 FUEL SYSTEM</b>	
Removal and Installation of Fuel Tank .....	3001
Removal and Installation of Fuel Supply Pump .....	3004A
Removal and Installation of Common Rail Assembly .....	3004B
Removal and Installation of Injector .....	3005
<b>4 ELECTRICAL SYSTEM</b>	
Electrical and Engine Basic Functions .....	4001A
Service Support .....	4001B
Function, Structure, Operation .....	4001C
Symptom .....	4001E
Functional Inspection .....	4001F
Maintenance Precautions .....	4001G
Removal and Installation of Starter Motor .....	4004
Removal and Installation of Alternator .....	4005
Preheating System .....	4008
Electrical Equipment Layout Diagram .....	4020A
Connection Connector Pin Layout .....	4020B
Sequence Circuit Diagram .....	4020C
Engine-side DTC List .....	4021
Main Unit-side DTC List .....	4022
Introduction to the trouble diagnosis .....	4023B
Engine Control System .....	4023D
Engine-side Trouble .....	4023G
Main Unit-side Trouble .....	4023H

# TABLE OF CONTENTS

DIVISION/SECTION	SECTION N°
Data Reference Values .....	4023K
Electrical Wiring Diagram .....	4040
<b>5 UNDERCARRIAGE</b>	
Removal and Installation of Shoe Assembly .....	5001A
Removal and Installation of Shoe Plate .....	5001B
Removal and Installation of Upper Roller .....	5003A
Assembly and Disassembly of Upper Roller .....	5003B
Removal and Installation of Lower Roller .....	5003C
Assembly and Disassembly of Lower Roller .....	5003D
Removal and Installation of the Sprocket .....	5004
Removal and Installation of Take-up Roller .....	5005A
Assembly and Disassembly of Take-up Roller .....	5005B
Removal and Installation of Grease Cylinder .....	5005C
Assembly and Disassembly of Grease Cylinder .....	5005D
<b>6 DRIVE TRAIN</b>	
Removal and Installation of Travel Motor .....	6001
Assembly and Disassembly of Travel Motor .....	6002
Removal and Installation of Swing Unit .....	6003
Assembly and Disassembly of Swing Unit .....	6004
<b>7 UNDERCARRIAGE HYDRAULICS</b>	
<b>8 UPPERSTRUCTURE HYDRAULICS</b>	
Overall view .....	8001A
Port Diagram .....	8001B
Pressure Measurement and Adjustment Procedures .....	8001D
Hydraulic Pump Flow Measurement Procedures .....	8001E
Drain Volume Measurement Procedures .....	8001F
Air Bleed Procedure .....	8001G
Removal and Installation of Hydraulic Oil Tank .....	8002
Removal and Installation of Hydraulic Pump .....	8003
Removal and Installation of Control Valve .....	8004
Removal and Installation of Bucket Cylinder .....	8005A
Removal and Installation of Arm Cylinder .....	8005B
Removal and Installation of Boom Cylinder .....	8005C
Removal and Installation of Center Joint .....	8006
Removal and Installation of Travel Remote Control Valve .....	8007A
Removal and Installation of Operation Remote Control Valve .....	8007B
Removal and Installation of 4 Stack Solenoid .....	8007C
Removal and Installation of Cushion Valve .....	8007D
Procedures for Assembly and Disassembly of Hydraulic Pump Main Unit .....	8008
Pump Main Unit Maintenance Standards .....	8010
Procedures for Assembly and Disassembly of Control Valve .....	8011
Procedures for Operation/Assembly and Disassembly of Hydraulic Cylinder .....	8012
Procedures for Assembly and Disassembly of Operation Remote Control Valve .....	8013
Procedures for Assembly and Disassembly of Travel Remote Control Valve .....	8014
Assembly and Disassembly of Cushion Valve .....	8016
Removal and Installation of Arm HBCV .....	8017A
Removal and Installation of Boom HBCV .....	8017B
Assembly and Disassembly of Center Joint .....	8018
Assembly and Disassembly of Swing Motor .....	8019
Explanation of Hydraulic Circuit and Operations (standard model) .....	8020A
Explanation of Hydraulic Circuit and Operations (option) .....	8020B

**<https://www.ebooklibonline.com>**

Hello dear friend!

Thank you very much for reading.

Enter the link into your browser.

The full manual is available for immediate download.

**<https://www.ebooklibonline.com>**

# TABLE OF CONTENTS

DIVISION/SECTION	SECTION N°
Structure and Operation Explanation of Hydraulic Pump .....	8030A
Structure and Operation Explanation of Travel Motor .....	8030B
Structure and Operation Explanation of Swing Motor .....	8030C
Structure and Operation Explanation of Control Valve .....	8030D
4 Stack Solenoid Valve Operation Explanation .....	8030E
Structure and Operation Explanation of Upper Pilot Valve (remote control valve) .....	8030F
Structure and Operation Explanation of Travel Pilot Valve (remote control valve) .....	8030G
Structure and Operation Explanation of Cushion Valve .....	8030H
<b>9 UPPERSTRUCTURE</b>	
Removal and Installation of Counterweight .....	9002
Removal and Installation of Bucket .....	9003A
Removal and Installation of Bucket Link .....	9003B
Removal and Installation of Arm .....	9003C
Removal and Installation of Boom .....	9003D
Removal and Installation of Operator's Seat .....	9004
Removal and Installation of Cab Assembly .....	9005A
Removal and Installation of Wiper .....	9005B
Removal and Installation of Wiper Controller .....	9005C
Removal and Installation of Wiper Motor .....	9005D
Removal and Installation of Monitor .....	9005E
Removal and Installation of Cab Front Glass .....	9005F
Window Lock Adjustment Procedures .....	9005G
Cab Tightening torque .....	9005H
Air Conditioner Overall Diagram .....	9006
Assembly and Disassembly of Air Conditioner Units .....	9007
Removal and Installation of Compressor .....	9009
Removal and Installation of Condenser .....	9010
Removal and Installation of Receiver Dryer .....	9011
Air Conditioning Gas Vacuum and Filling Operations .....	9015
<b>10 LARGE SIZE SCHEMATICS</b>	
Large size hydraulic schematics .....	84402838EN
Large size electrical schematics .....	84402837EN

NOTE: CNH France S.A. Company reserves the right to make changes in the specification and design of the machine without prior notice and without incurring any obligation to modify units previously sold.

The description of the models shown in this manual has been made in accordance with the technical specifications known as of the date of design of this document.

All data given in this manual is subject to production variations. Dimensions and weights are provided with approximate values and the machine fitting shown in the illustrations may not correspond with standard models. For precise information on specific machine models and versions, please contact your CASE dealer.

Reproduction or translation, even partial, is prohibited without written authorization from CNH France SA Company.



# Section

# 1001

**Safety, general information and standard torque data**

# Safety, general information and standard torque data

---

## GENERAL INFORMATION

### CLEANING

Clean all metal parts except bearings, in a suitable cleaning solvent or by steam cleaning.

Do not use caustic soda for steam cleaning.

After cleaning, dry and put oil on all parts.

Clean oil passages with compressed air.

Clean bearings in a suitable cleaning solvent, dry the bearings completely and put oil on the bearings.

### INSPECTION

Check all parts when the parts are disassembled.

Replace all parts that have wear or damage.

Small scoring or grooves can be removed with a hone or crocus cloth.

Complete a visual inspection for indications of wear, pitting and the replacement of parts necessary to prevent early failures.

### BEARINGS

Check bearings for easy action.

If bearings have a loose fit or rough action replace the bearing.

Wash bearings with a suitable cleaning solvent and permit to air dry.

DO NOT DRY BEARINGS WITH COMPRESSED AIR.

### NEEDLE BEARINGS

Before you press needle bearings in a bore always remove any metal protrusions in the bore or edge of the bore.

Before you press bearings into position put petroleum jelly on the inside and outside diameter of the bearings.

### GEARS

Check all gears for wear and damage.

Replace gears that have wear or damage.

Oil seals, O-rings and gaskets.

Always install new oil seals, O-rings and gaskets.

Put petroleum jelly on seals and O-rings.

### SHAFTS

Check all shafts that have wear or damage.

Check the bearing and oil seal surfaces of the shafts for damage.

### SERVICE PARTS

Always install genuine Case service parts.

When ordering refer to the

Parts Catalogue for the correct part number of the genuine Case replacement items.

Failures due to the use of other than genuine Case replacement parts are not covered by warranty.

### LUBRICATION

Only use the oils and lubricants specified in the Operator's or Service Manuals.

Failures due to the use of non-specified oils and lubricants are not covered by warranty.

# Safety, general information and standard torque data

## Safety



This symbol means ATTENTION! BECOME ALERT! YOUR SAFETY IS INVOLVED. The message that follows the symbol contains important information about safety. Carefully read the message. Make sure you fully understand the causes of possible injury or death.

To prevent injury always follow the Warning, Caution and Danger notes in this section and throughout the manual. Put the warning tag shown below on the key for the key switch when servicing or repairing the machine. One warning tag is supplied with each machine. Additional tags are available from your service parts supplier.

### **⚠ WARNING**

**Read the operator's manual to familiarize yourself with the correct control functions.**

### **⚠ WARNING**

**Operate the machine and equipment controls from the seat position only. Any other method could result in serious injury.**

### **⚠ WARNING**

**This is a one man machine, no riders allowed.**

### **⚠ WARNING**

**Before starting engine, study Operator's Manual safety messages.  
Read all safety signs on machine.  
Clear the area of other persons.  
Learn and practice safe use of controls before operating.  
It is your responsibility to understand and follow manufacturers instructions on machine operation, service and to observe pertinent laws and regulations.  
Operator's and Service Manuals may be obtained from your CASE dealer.**

### **⚠ WARNING**

**If you wear clothing that is too loose or do not use the correct safety equipment for your job, you can be injured.  
Always wear clothing that will not catch on objects.  
Extra safety equipment that can be required includes hard hat, safety shoes, ear protection, eye or face protection, heavy gloves and reflector clothing.**

### **⚠ WARNING**

**When working in the area of the fan belt with the engine running, avoid loose clothing if possible, and use extreme caution.**

### **⚠ WARNING**

**When doing checks and tests on the equipment hydraulics, follow the procedures as they are written. DO NOT change the procedure.**

### **⚠ WARNING**

**When putting the hydraulic cylinders on this machine through the necessary cycles to check operation or to remove air from a circuit, make sure all people are out of the way.**

### **⚠ WARNING**

**Use insulated gloves or mittens when working with hot parts.**

# Safety, general information and standard torque data

## **⚠ WARNING**

Lower all attachments to the ground or use stands to safely support the attachments before you do any maintenance or service.

## **⚠ WARNING**

Pin sized and smaller streams of hydraulic oil under pressure can penetrate the skin and result in serious infection.

If hydraulic oil under pressure does penetrate the skin, seek medical treatment immediately.

Maintain all hoses and tubes in good condition.

Make sure all connections are tight.

Make a replacement of any tube or hose that is damaged or thought to be damaged.

DO NOT use your hand to check for leaks, use a piece of cardboard or wood.

## **⚠ WARNING**

When removing hardened pins such as a pivot pin, or a hardened shaft, use a soft head (brass or bronze) hammer or use a driver made from brass or bronze and a steel head hammer.

## **⚠ WARNING**

When using a hammer to remove and install pivot pins or separate parts using compressed air or using a grinder, wear eye protection that completely encloses the eyes (approved goggles or other approved eye protectors).

## **⚠ WARNING**

Use suitable floor (service) jacks or chain hoist to raise wheels or tracks off the floor.  
Always block machine in place with suitable safety stands.

## **⚠ WARNING**

When servicing or repairing the machine, keep the shop floor and operator's compartment and steps free of oil, water, grease, tools, etc.

Use an oil absorbing material and/or shop cloths as required.

Use safe practices at all times.

## **⚠ WARNING**

Some components of this machine are very heavy.  
Use suitable lifting equipment or additional help as instructed in this Service Manual.

## **⚠ WARNING**

Engine exhaust fumes can cause death.

If it is necessary to start the engine in a closed place, remove the exhaust fumes from the area with an exhaust pipe extension.

Open the doors and get outside air into the area.

## **⚠ WARNING**

When the battery electrolyte is frozen, the battery can explode if (1), you try to charge the battery, or (2), you try to jump start and run the engine.

To prevent the battery electrolyte from freezing, try to keep the battery at full charge.

If you do not follow these instructions, you or others in the area can be injured.



# Section

# 2000

**Removal and Installation of Engine Assembly**

# Removal and Installation of Engine Assembly

## ⚠ WARNING

- Keep away from fire.
- Be sure to release hydraulic pressure before beginning work.
- The air conditioner circuit is filled with high-pressure gas, so there is the danger of gas spraying out when loosening lines.
- Do not use open flames and do not allow sparks near the battery.

## ⚠ CAUTION

- Be sure to stop the engine before beginning work.
- Be sure to inspect the wire rope and other lifting equipment before beginning work.
- Do not stand or pass under the suspended load.

### Items to prepare

- Wrenches (7 mm, 8 mm, 13 mm, 17 mm, 19 mm, 36 mm)
- Box wrench (30 mm)
- Shackle (with the required lifting capacity) x 2
- Wire ropes (with the required breaking load)
- Liftcrane (with the required lifting capacity)
- Marking pen
- Cap
- Plug
- Waste oil can
- Rag
- Cleaning fluid
- Wood planks, etc.

## Removal of Engine Assembly

1. Drain the engine oil.(For details, see "Engine Oil Replacing".)
2. Drain the coolant from the radiator.(For details, see "Removal and Installation of Radiator".)
3. Remove the engine hood.(For details, see "Removal and Installation of Engine Hood".)
4. Remove the hydraulic pump.(For details, see "Removal and Installation of Hydraulic Pump".)
5. Use a wrench (13 mm) to remove the 3 bolts (1).

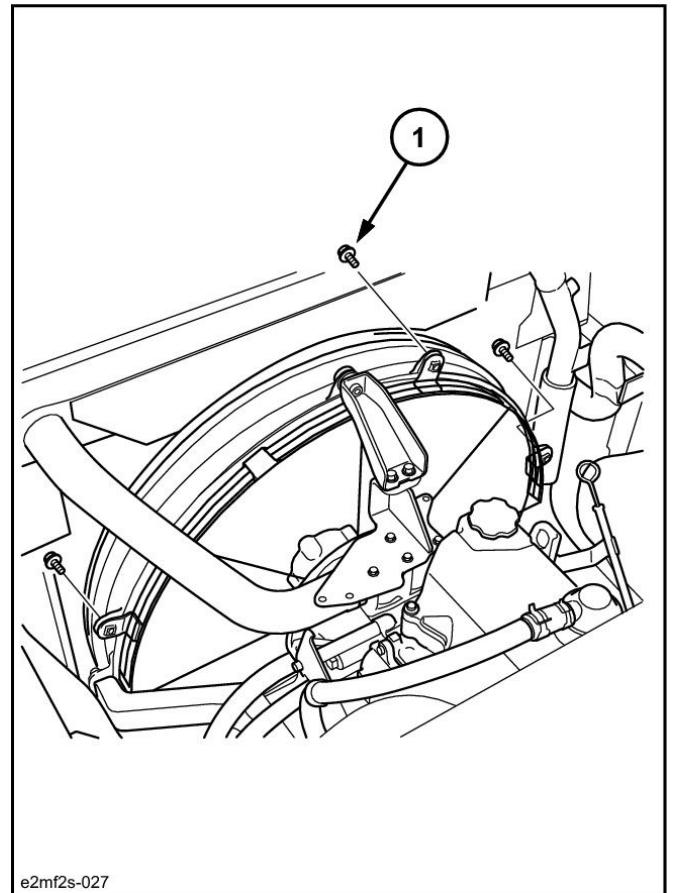

# Removal and Installation of Engine Assembly

6. Use a wrench (13 mm) to remove the 3 bolts (1), and then remove the bracket (2).

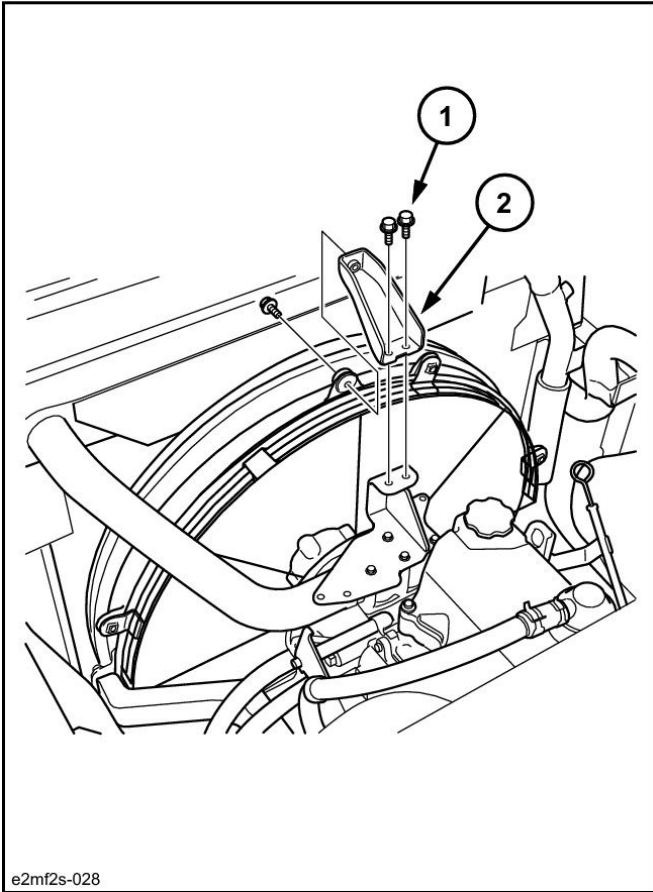

7. Remove the fan guard (1).

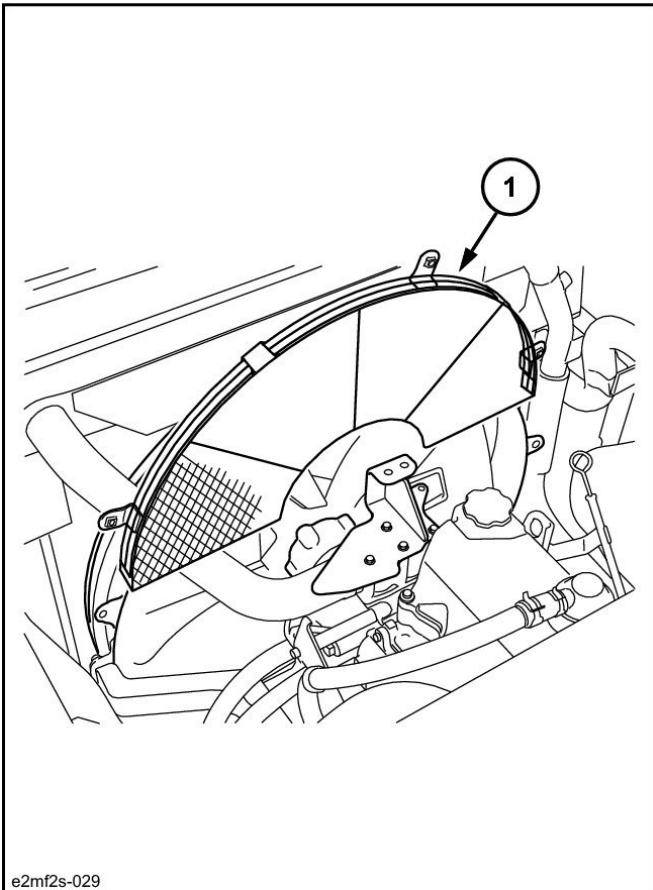

8. Use a wrench (8 mm) to loosen the hose band (1) on the radiator, and then remove the upper hose (2).

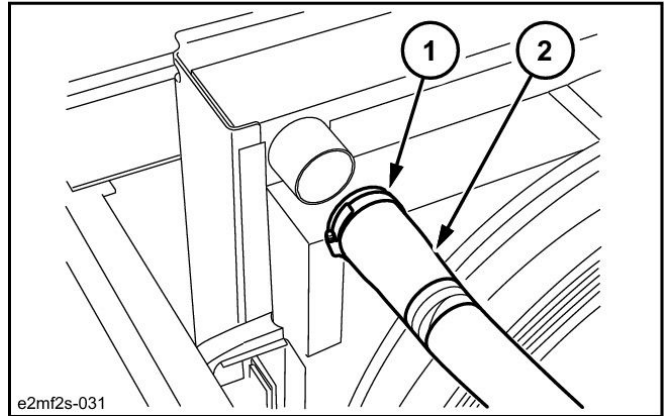

9. Remove the cushion seal on the side of the radiator, use a wrench (8 mm) to loosen the hose band (1) of the radiator, and then remove the lower hose (2).

- Use caps to cover the radiator and hoses to prevent the entry of water, dust or dirt.
- Before removing the radiator hoses, completely drain the coolant.

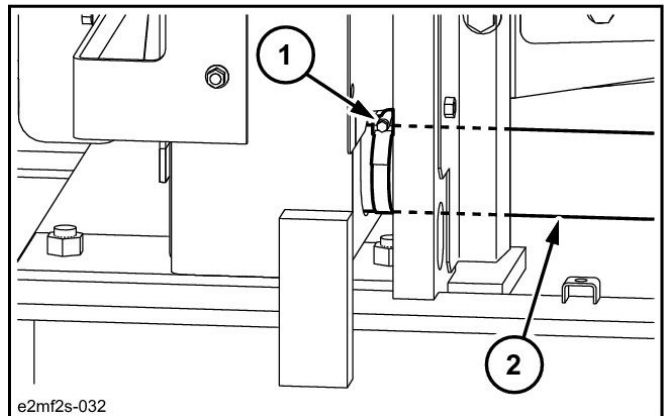

10. Use a wrench (13 mm) to loosen the line bolts (1) in 2 locations, and then remove the 2 lines (2) and (3) from the compressor.

- Always remove the low-pressure (suction side) line (2) first.
- Attach caps or plugs to the compressor and lines to prevent any entry of water, dust or dirt.

Tightening torque for bolt installation: 19.6 - 24.5 N•m

# Removal and Installation of Engine Assembly

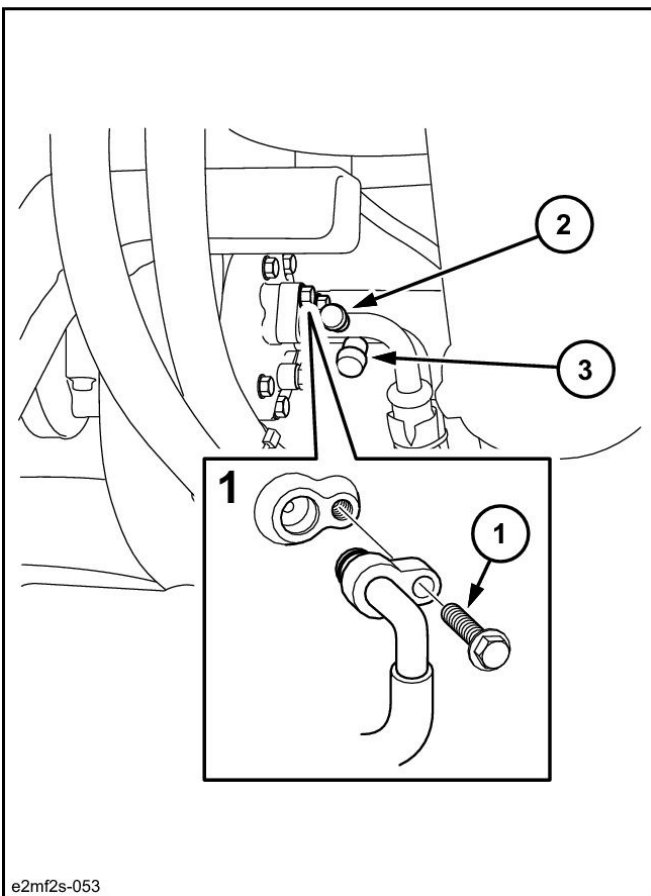

11. Use a wrench (8 mm) to loosen the hose band (1) on the inter cooler, and then remove the hose (2).
- Use caps to cover the lines and hoses to prevent the entry of water, dust or dirt.

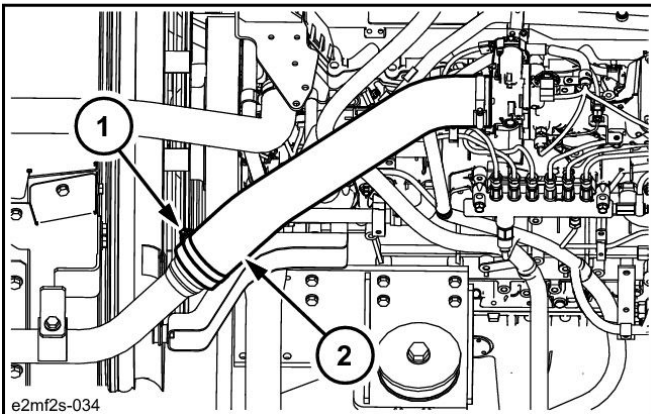

12. Use a wrench (17 mm) to remove the 5 bolts (1), and then remove the under cover (2).

- Use caution when removing as the parts are heavy.

Tightening torque for bolt installation: 63.7 - 73.5 N•m

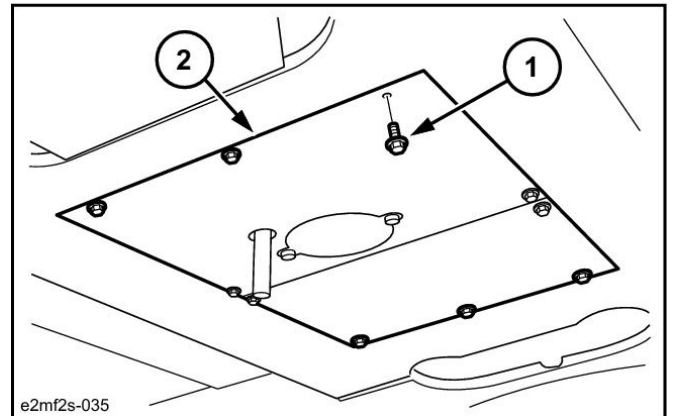

13. Prepare the waste oil can (1).

- Drain the engine oil before removing the engine oil hose.

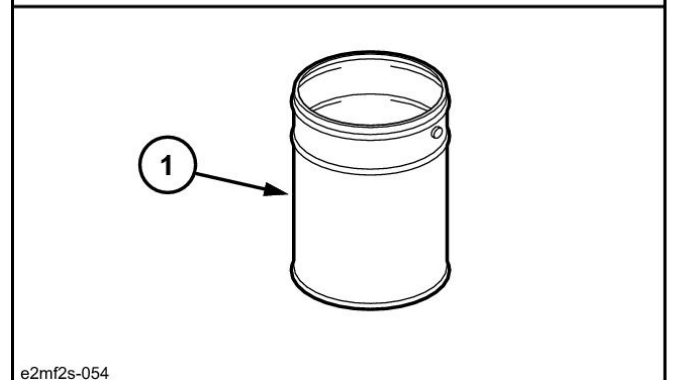
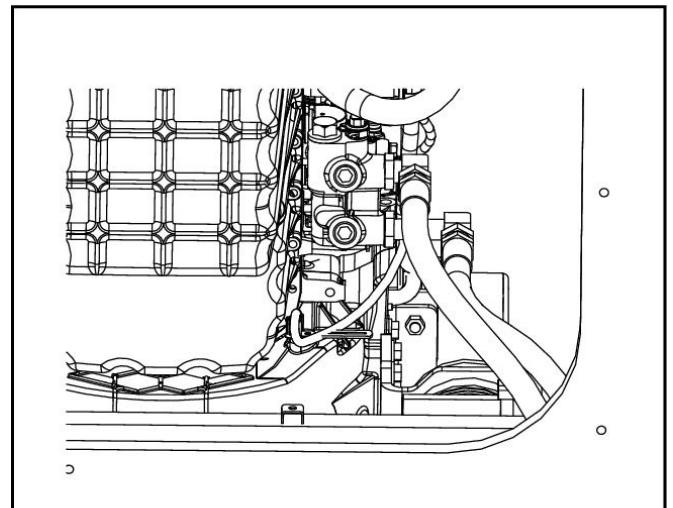

14. Use a wrench (36 mm) to remove the 2 engine oil remote hoses (1).

- Mark the engine and hoses so that the connectors match at the time of assembly.
- Attach caps or plugs to the engine and hoses to prevent any entry of water, dust or dirt.

# Removal and Installation of Engine Assembly

- Clean the engine and hoses by spraying them with a parts cleaner to prevent scratches and prevent dirt from accumulating on the connectors.

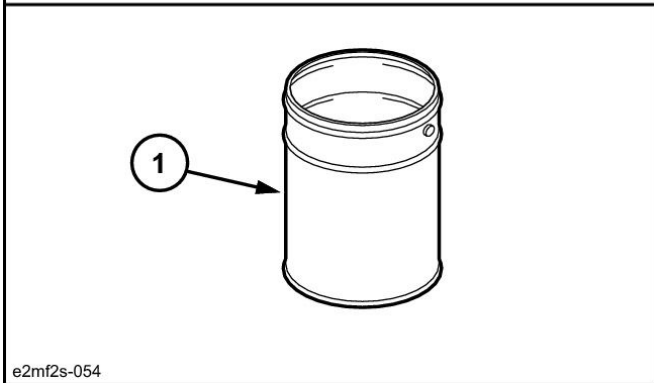
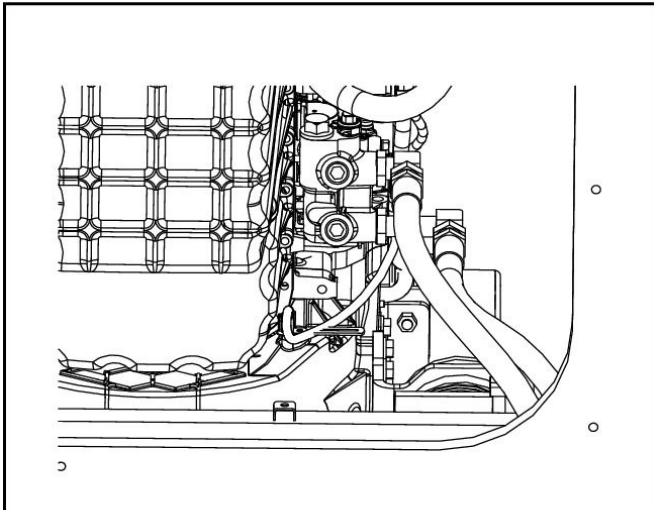

15. Use a wrench (17 mm) to remove the bolt (1), and then remove the battery cable (2) on the negative side.

- When removing the terminal and harness, secure them so that they do not interfere with the frame.
- Also, cover with a rubber cap to protect against sparks.

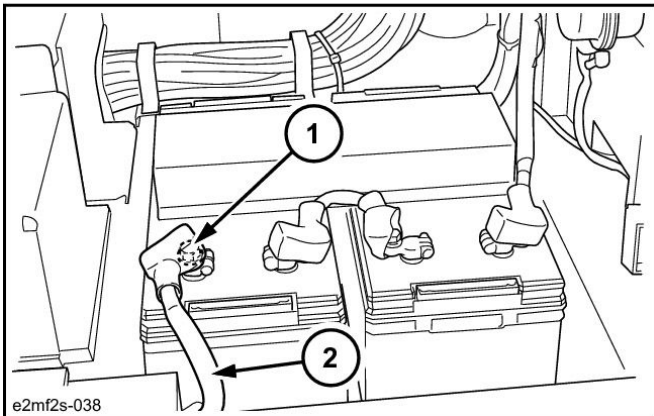

16. Use a wrench (17 mm) to remove the 5 bolts (1), and then remove the under cover (2).  
Tightening torque for bolt installation: 63.7 - 73.5 N•m

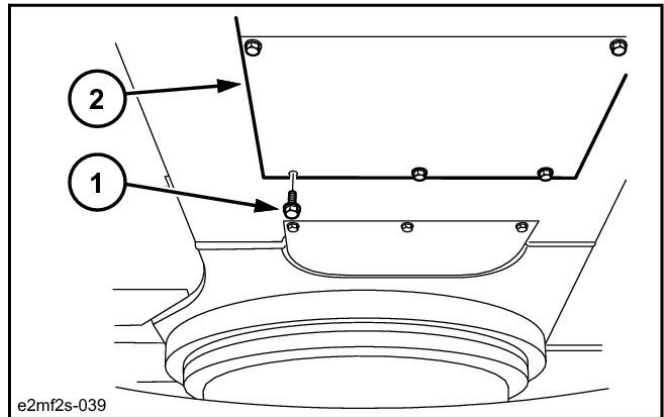

17. Use a wrench (8 mm) to remove the 2 nuts (1), and then remove the wiring (2) from the starter motor.

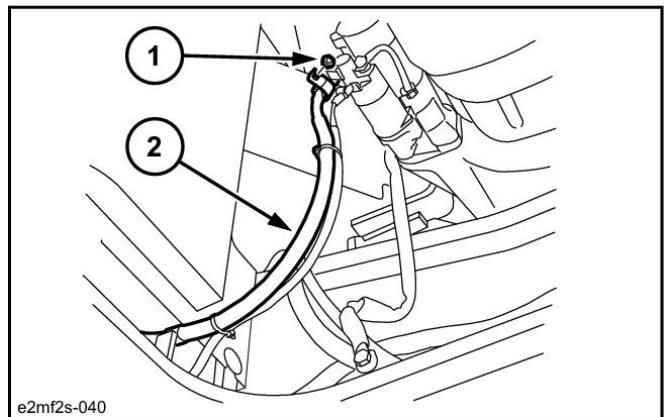

18. Remove the hose band (1), and then remove the fuel hose (2).

- Attach caps or plugs to the engine and hoses to prevent any entry of water, dust or dirt.

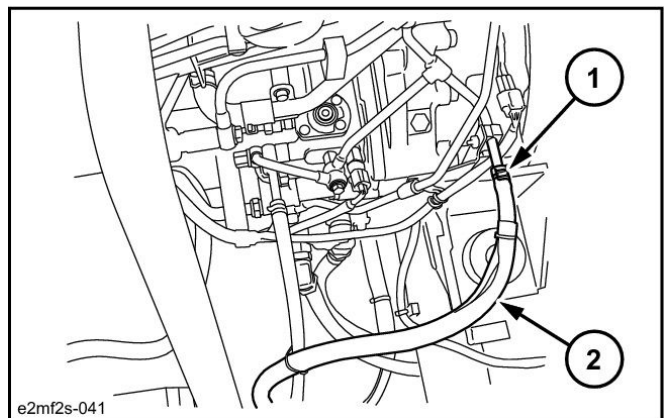

# Removal and Installation of Engine Assembly

19. Remove the hose band (1), and then remove the fuel hose (2).

- Attach caps or plugs to the engine and hoses to prevent any entry of water, dust or dirt.

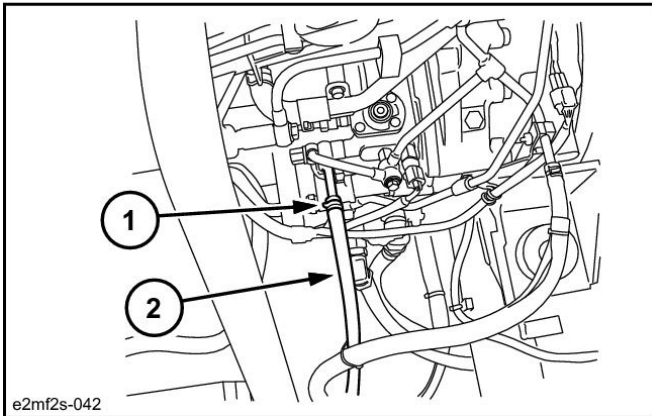

20. Use a wrench (13 mm) to remove the 4 bolts (1), and then remove the box cover (2).

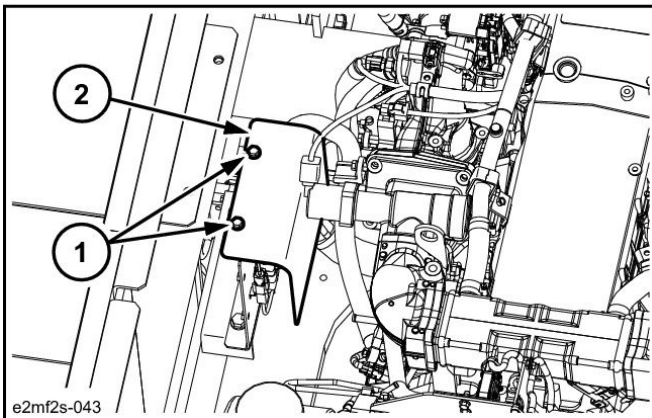

21. Remove the connectors (1) in the box.

- Wrap the removed connectors in plastic after tying them together to prevent any entry of water, dust or dirt.

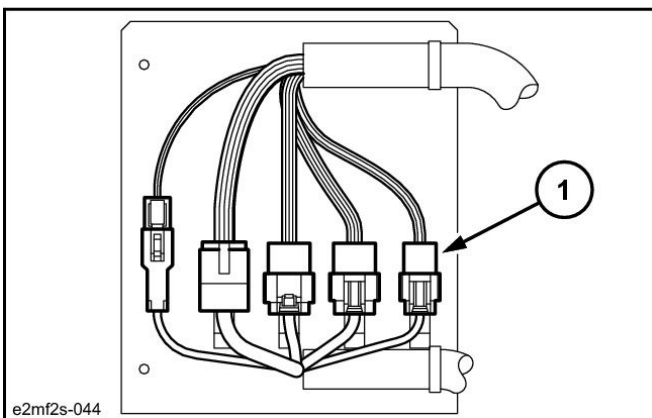

22. Use a wrench (8 mm) to loosen the hose band (1), and then remove the heater hose (2). Attach caps or plugs to the engine and hoses to prevent any entry of water, dust or dirt.

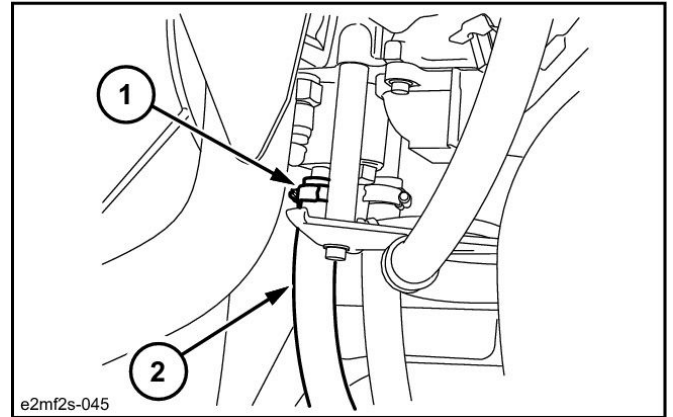

23. Use a wrench (8 mm) to loosen the hose band (1), and then remove the heater hose (2).

- Attach caps or plugs to the engine and hoses to prevent any entry of water, dust or dirt.

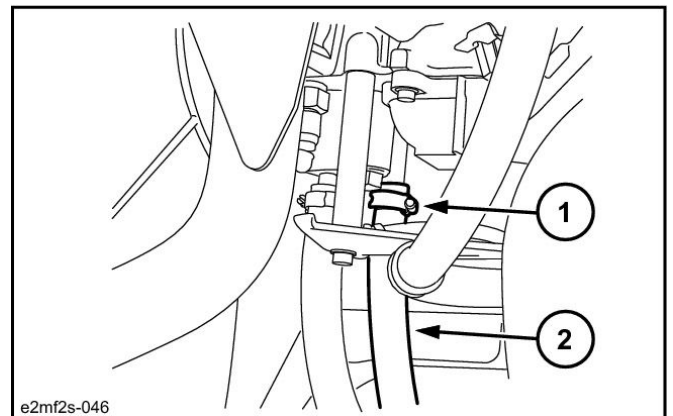

24. Use a wrench (8 mm) to loosen the hose band (1), and then remove the radiator hose (2).

- Use caps to cover the lines and hoses to prevent any entry of water, dust or dirt.

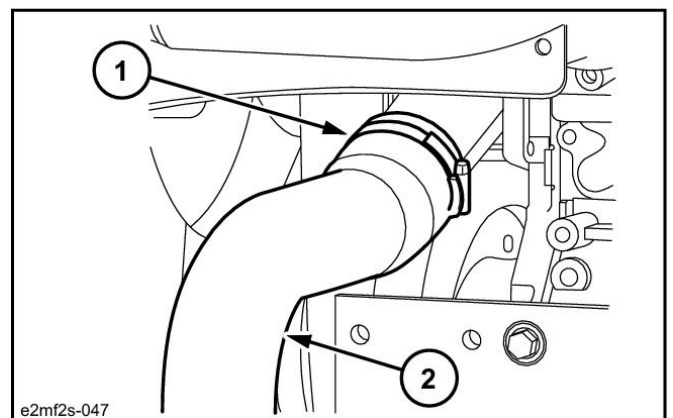

# Removal and Installation of Engine Assembly

25. Use a wrench (8 mm) to loosen the hose band (1), and then remove the air hose (2).

- Use caps to cover the lines and hoses to prevent any entry of water, dust or dirt.

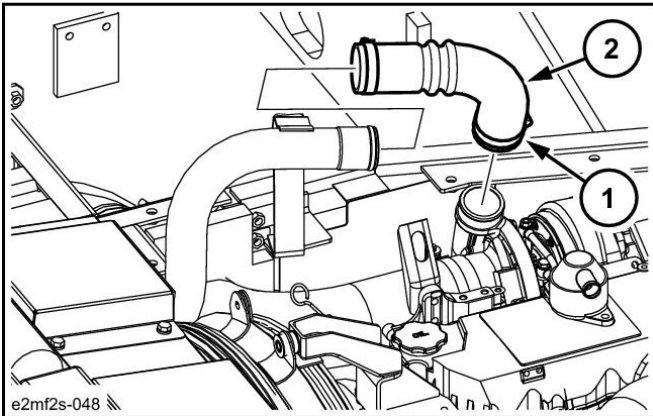

26. Use a wrench (8 mm) to loosen the hose band (1), and then remove the air hose (2).

- Use caps to cover the lines and hoses to prevent any entry of water, dust or dirt.

Tightening torque for bolt installation: 8.8 - 9.8 N•m

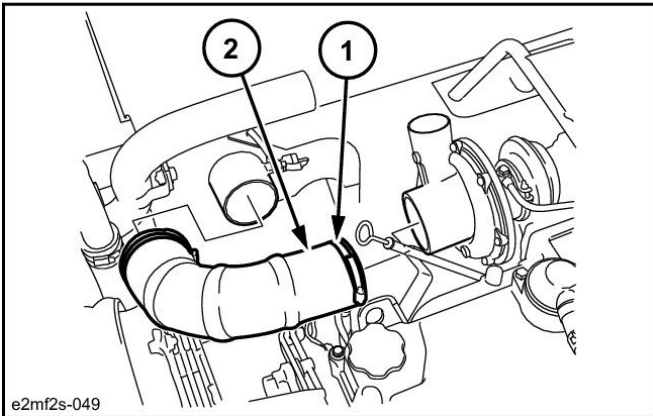

27. Remove the connectors (1) from the alternator.

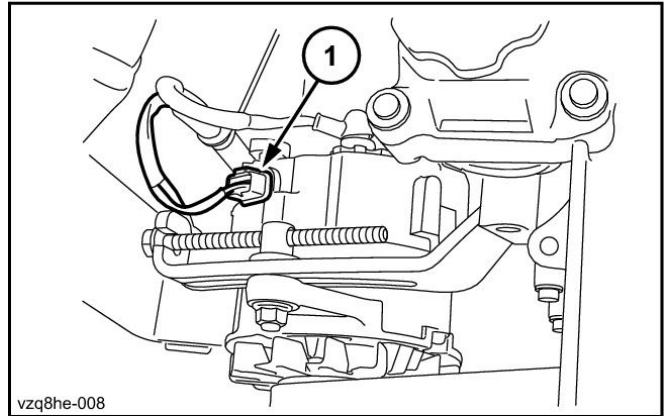

28. Remove the cap (1), use the wrench (10 mm) to remove the nut (2), and then remove the alternator wiring (3).

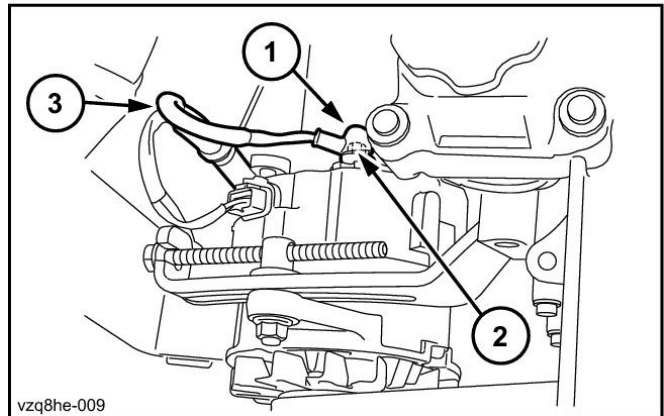

29. Install the 2 shackles (1), and then use the wire rope (2) and liftcrane to secure the engine main unit.

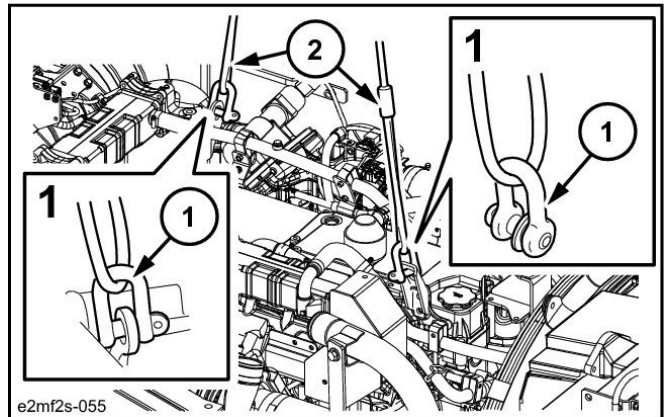

# Removal and Installation of Engine Assembly

30. Use a box wrench (30 mm) to remove the 4 bolts (1) from the mount.  
Tightening torque for bolt installation: 289 - 337 N·m

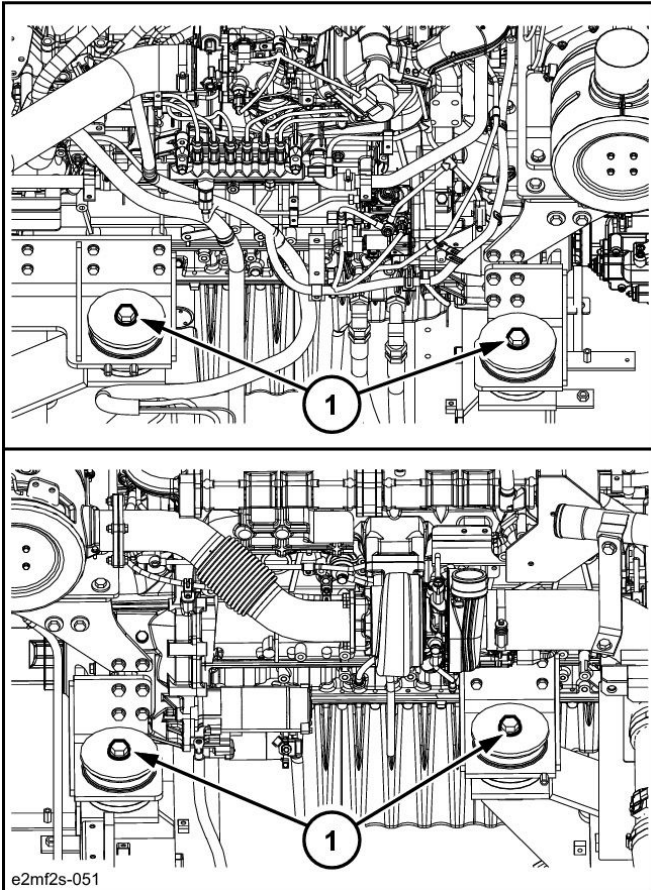

31. Use the wire rope (1) and liftcrane to lift the engine main unit.  
Thoroughly check that the location is safe before lowering the engine on wood planks, etc.

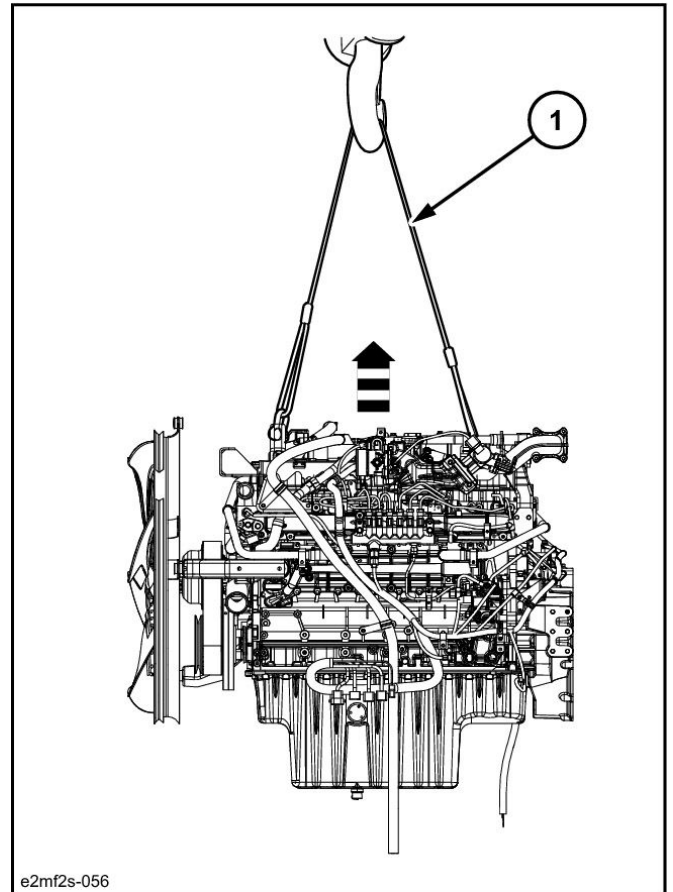

# Removal and Installation of Engine Assembly

---

## Installation of Engine Assembly

1. To install the engine, perform the reverse of the removal procedure.  
Tighten bolts being installed to the specified torque. For bolts for which the torque is not specified, see "Standard Torque Data for Cap Screws and Nuts".  
After installing the engine, resupply coolant and engine oil, perform fuel line air bleeding, and perform filling for the air conditioner gas.  
For details, see the individual explanations for each procedure.
2. Run the engine at no-load idling and check for any water or oil leaks.
3. Attach the hydraulic pump, covers, and counterweight.  
For details, see the individual explanations for each procedure.

# Removal and installation of the fuel cooler engine inter-cooler radiator and oil cooler

## Removal and Installation of Fuel Cooler

### ⚠ CAUTION

- Be sure to stop the engine before beginning work.
- As the fuel hose will be removed, strictly prohibit open flames.

### Items to prepare

- Wrench (13 mm)
- Screwdriver
- Pliers
- Marking pen
- Cap
- Plug
- Rag
- Cleaning fluid
- Drip pan

## Removal of Fuel Cooler

1. Mark the fuel cooler and hoses (1) and (2) so that the connectors match at the time of assembly. Use pliers to loosen the hose bands (3) and (4), and then remove the hoses. Fuel will spill out, so place a drip pan directly below the area. Attach caps or plugs to the fuel cooler and hoses to prevent any entry of water, dust or dirt.

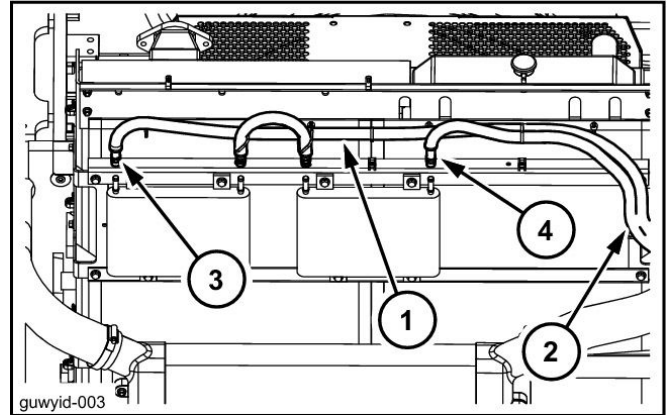

2. Use a wrench (13 mm) to remove the 4 bolts (1), and then remove the fuel cooler (2).

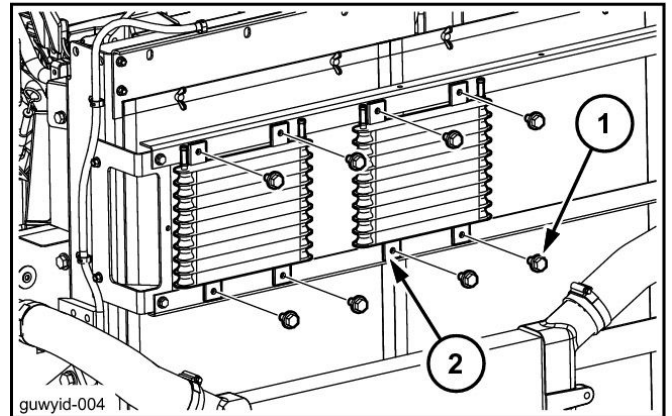

## Installation of Fuel Cooler

- To installation, perform the reverse of the removal procedure.
- After connecting the hoses, carefully check for any fuel leaks.
- Tighten bolts being installed to the specified torque.
- For bolts for which the torque is not specified, see "Standard Torque Data for Cap Screws and Nuts".

# Removal and installation of the fuel cooler engine inter-cooler radiator and oil cooler

## Removal and Installation of Engine Inter Cooler

### ⚠ CAUTION

- Be sure to stop the engine before beginning work.
- As the fuel hose will be removed, strictly prohibit open flames.

### Items to prepare

- Wrenches (8 mm, 13 mm)
- Flathead screwdriver
- Wire cutters
- Cap
- Rag
- Cleaning fluid

## Removal of Inter Cooler

1. Remove the fuel cooler. (For details, see "Removal and Installation of Fuel Cooler".)  
Use a wrench (13 mm) to remove the 4 bolts (1), and then remove the bracket (2) from the fuel cooler.

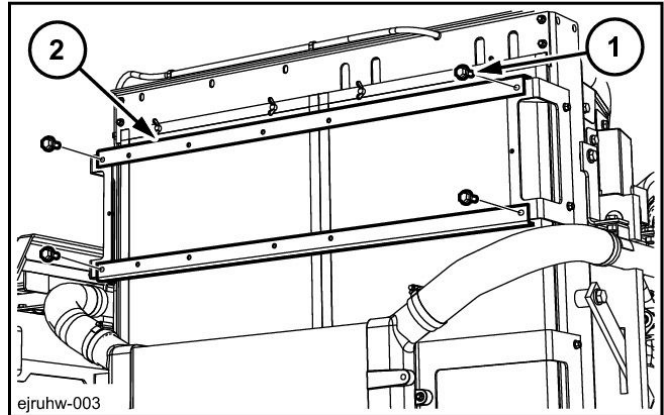

2. Use a wrench (8 mm) or flathead screwdriver to loosen the hose bands (1) in the 2 locations, and then remove the 2 hoses (2) and (3).  
Use caps to cover the inter cooler and hoses to prevent the entry of water, dust or dirt.

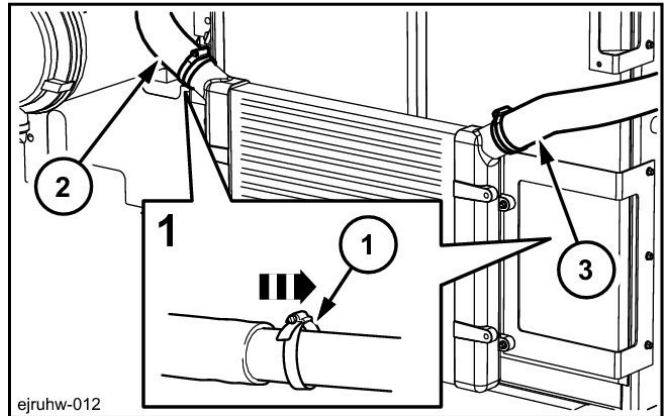

3. Use a wrench (13 mm) to remove the 4 bolts (1), and then remove the inter cooler (2).

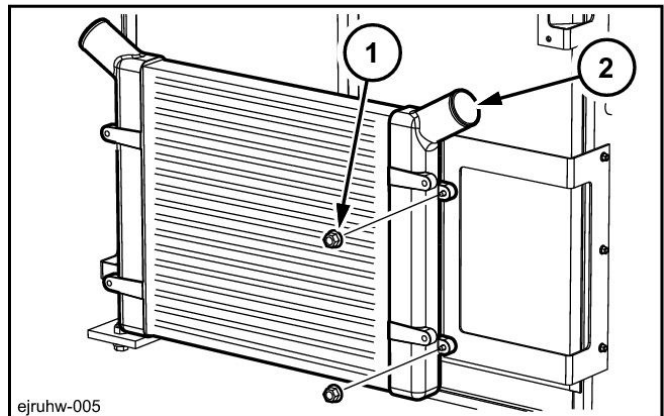

# Removal and installation of the fuel cooler engine inter-cooler radiator and oil cooler

---

## Installation of Inter Cooler

To install, perform the reverse of the removal procedure. Check for any air leaks. Tighten bolts being installed to the specified torque. For bolts for which the torque is not specified, see "Standard Torque Data for Cap Screws and Nuts".

## Removal and Installation of Radiator

### ⚠ WARNING

- **Do not remove the radiator cap when the radiator coolant temperature is high. Hot liquid could spray out.**

### ⚠ CAUTION

- **Be sure to release hydraulic pressure before beginning work.**
- **Be sure to stop the engine before beginning work.**
- **Be sure to inspect the wire rope and other lifting equipment before beginning work.**
- **Do not stand or pass under the suspended load.**

### Items to prepare

- Wrenches (8 mm, 14 mm, 19 mm)
- Box wrenches (8 mm, 10 mm)
- Pliers
- Shackle (with the required lifting capacity) x 2
- Wire ropes (with the required breaking load)
- Liftcrane (with the required lifting capacity)
- Caps
- Plugs
- Drain tank
- Drain hose
- Rag
- Cleaning fluid
- Wood planks, etc.

# Removal and installation of the fuel cooler engine inter-cooler radiator and oil cooler

## Removal of Radiator

1. Use a wrench (19 mm) to remove the 5 bolts (1), and then remove the under cover (2).

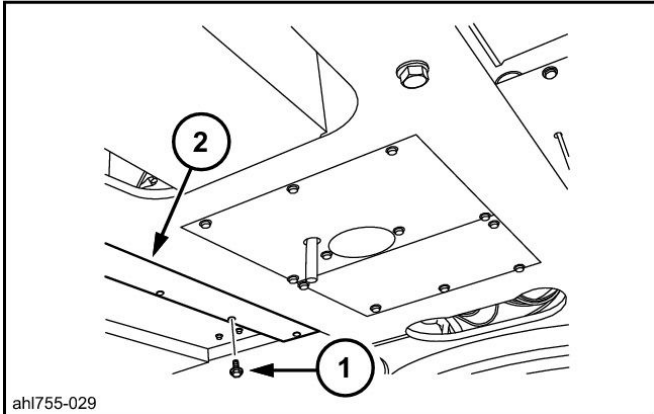

2. Install the drain hose (1), and then prepare the drain tank (2).

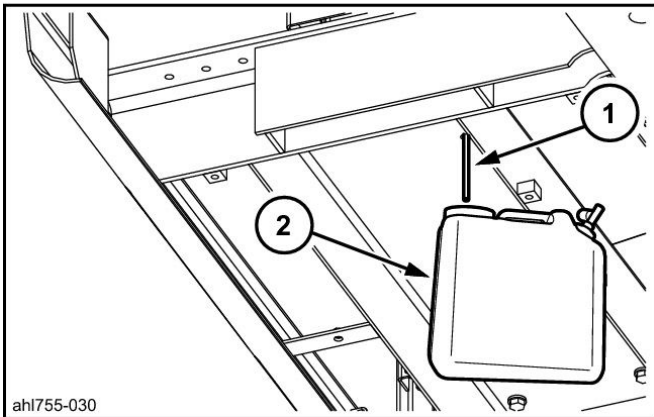

3. To make it easier to drain the coolant, remove the radiator cap (1).

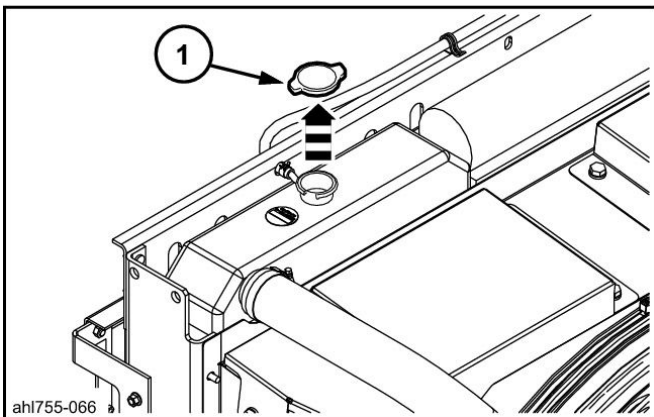

4. Loosen the drain plug (1), and then drain the coolant.

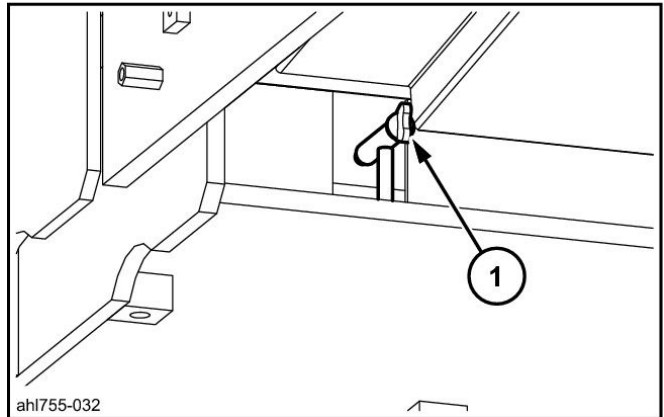

5. Use a wrench (8 mm) to loosen the hose band (1), and then remove the hose (2).

- Use caps to cover the lines and hoses to prevent any entry of water, dust or dirt.

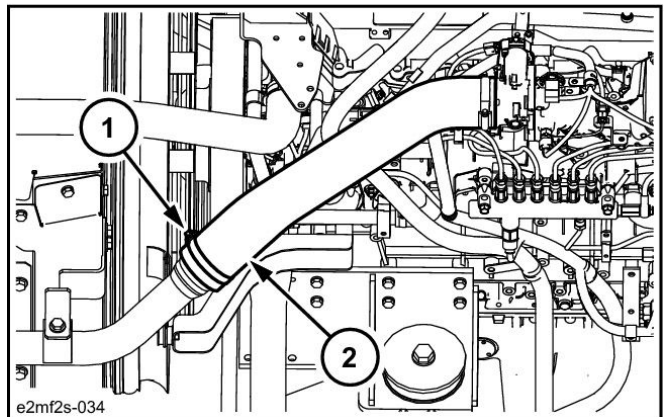

6. Use a box wrench (13 mm) to remove the 1 nut (1) and the 3 bolts (2) of the radiator cover.

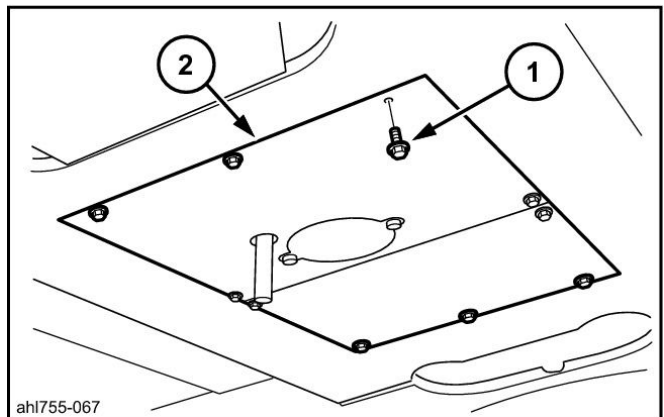

# Removal and installation of the fuel cooler engine inter-cooler radiator and oil cooler

7. Use a wrench (8 mm) to loosen the hose band (1) on the radiator, and then remove the upper hose (2).

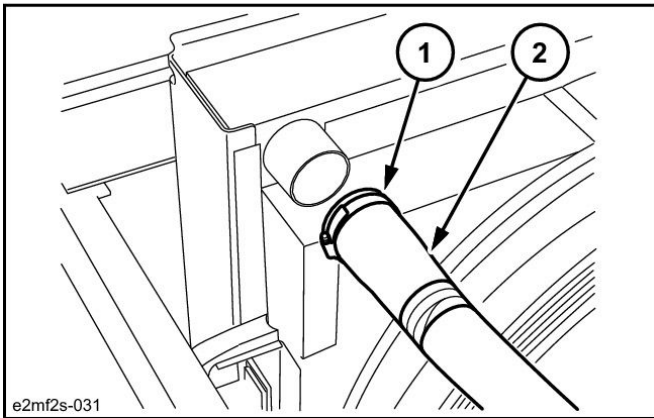

8. Remove the cushion seal on the side of the radiator, use a wrench (8 mm) to loosen the hose band (1) of the radiator, and then remove the lower hose (2).

- Use caps to cover the radiator and hoses to prevent the entry of water, dust or dirt.
- Before removing the radiator hoses, completely drain the coolant.

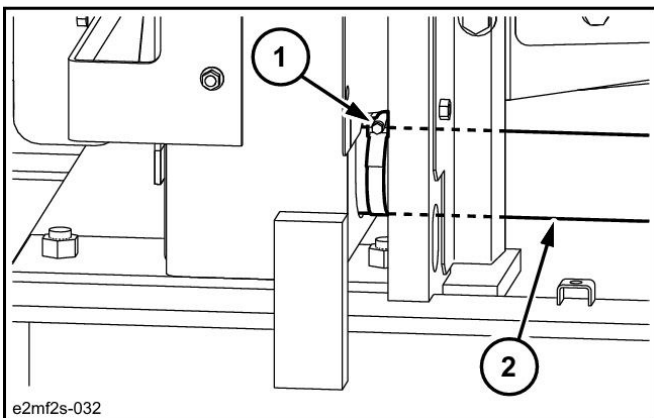

9. Remove the drain plug (1), loosen the hose band (2), and then remove the hose (3).

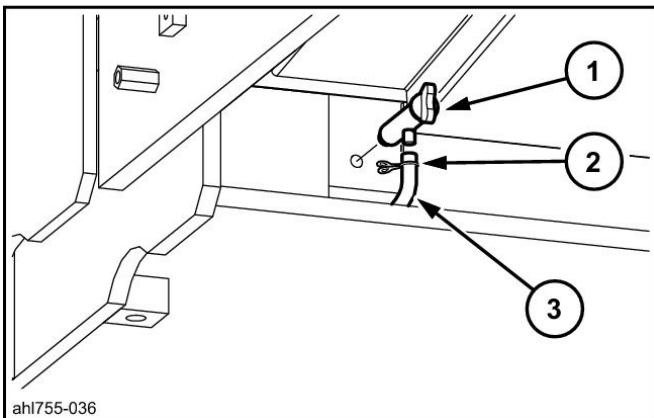

10. Loosen the hose band (2), and then remove the hose (1) from the radiator cap.

- Attach caps or plugs to the hoses to prevent any entry of water, dust or dirt.

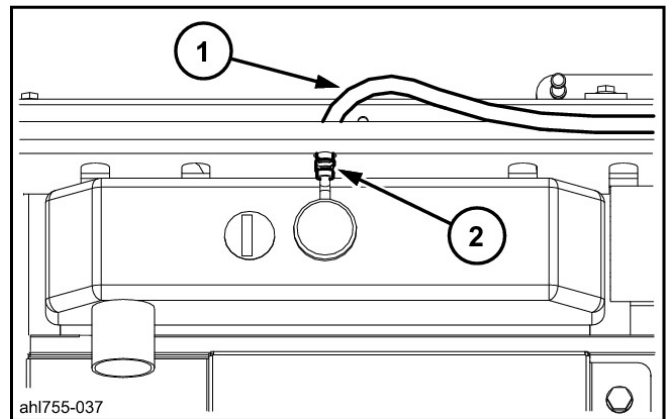

11. Use a wrench (13 mm) to remove the 3 bolts (1).

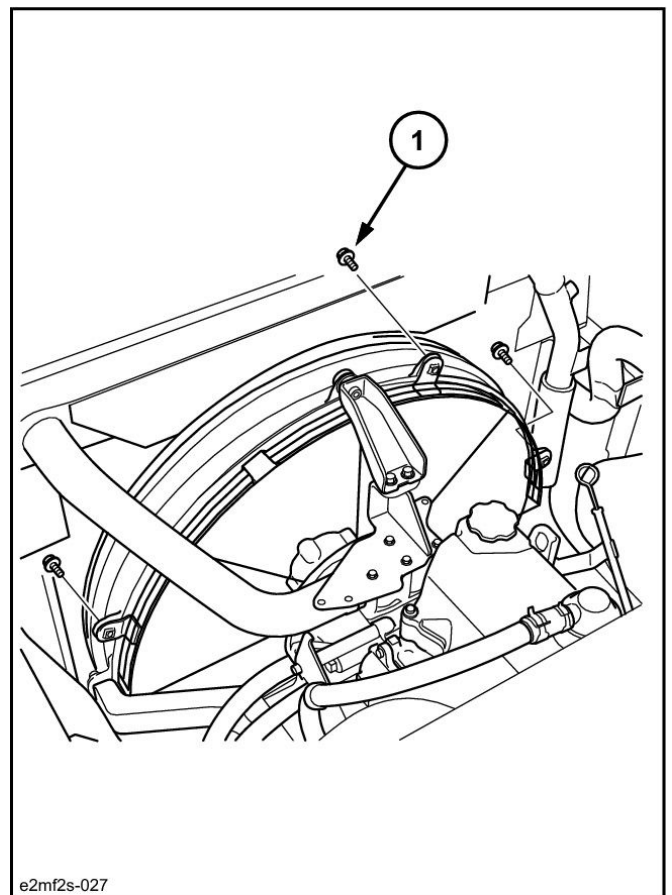

# Removal and installation of the fuel cooler engine inter-cooler radiator and oil cooler

12. Use a wrench (13 mm) to remove the 3 bolts (1), and then remove the bracket (2)

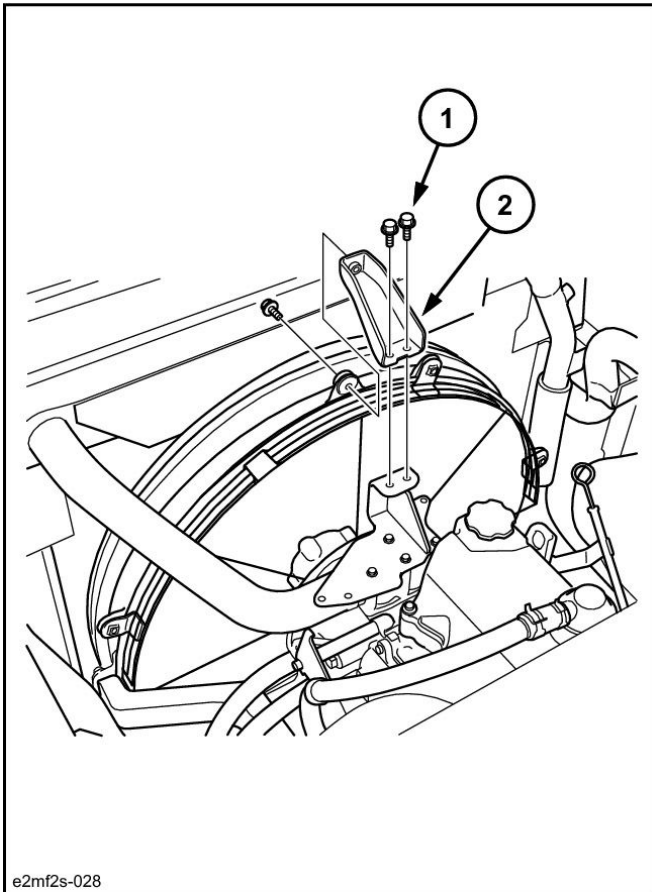

13. Remove the fan guard (1).

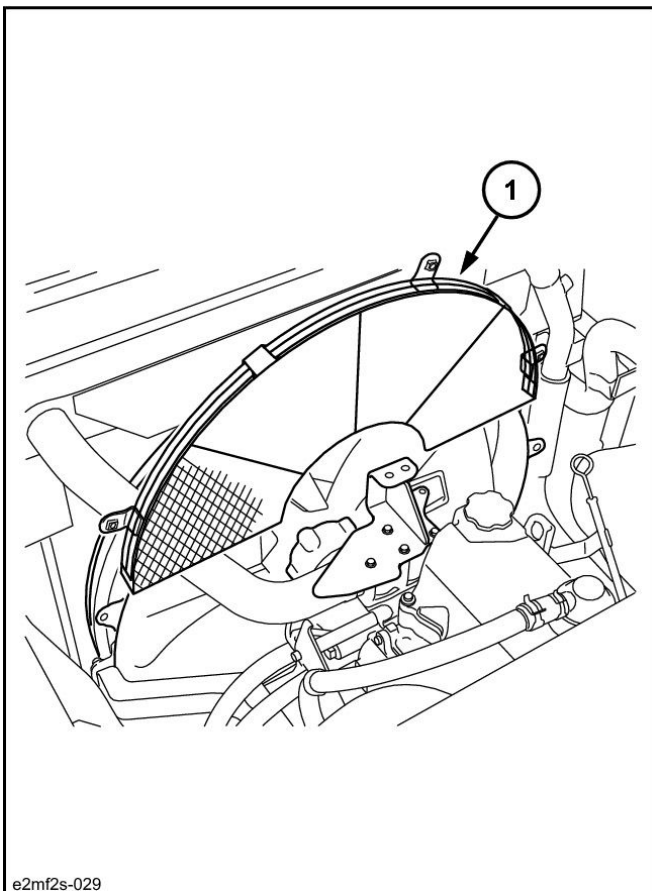

14. Remove the 2 butterfly bolts (1), and then remove the front anti-insect net (2).

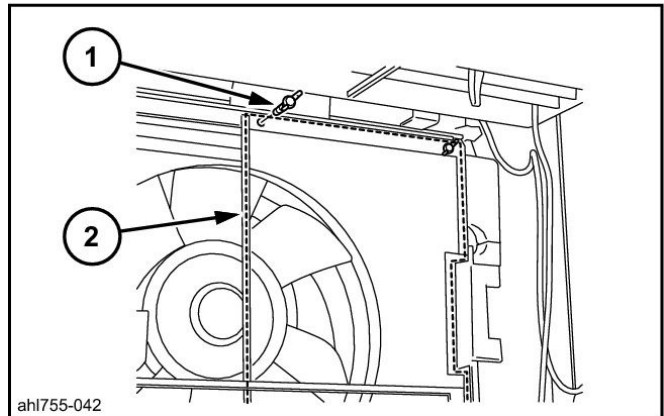

15. Install the 2 shackles (1) to the top of the radiator, and then use the wire rope (2) and liftcrane to lift the radiator.

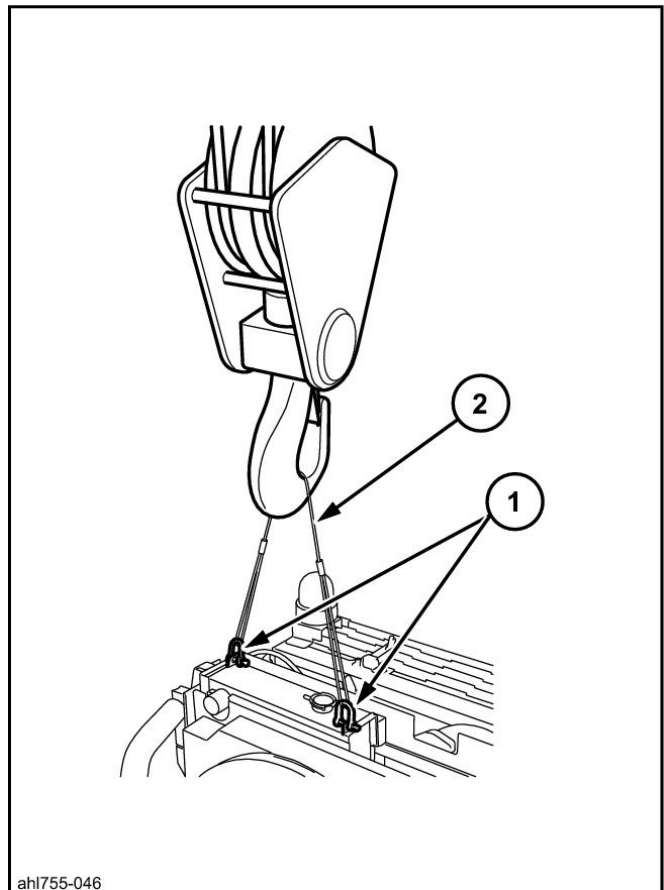

# Removal and installation of the fuel cooler engine inter-cooler radiator and oil cooler

16. Lift the radiator together with the radiator cover (2) until the fixtures (1) at the bottom of the radiator become disconnected.

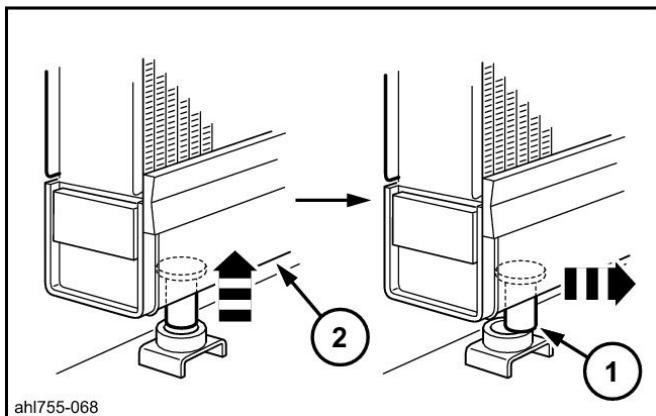

17. Thoroughly check that the location is safe before lowering the radiator on square wooden pieces. When laying down the radiator, be careful not to bend or crush the bottom fixtures (1).

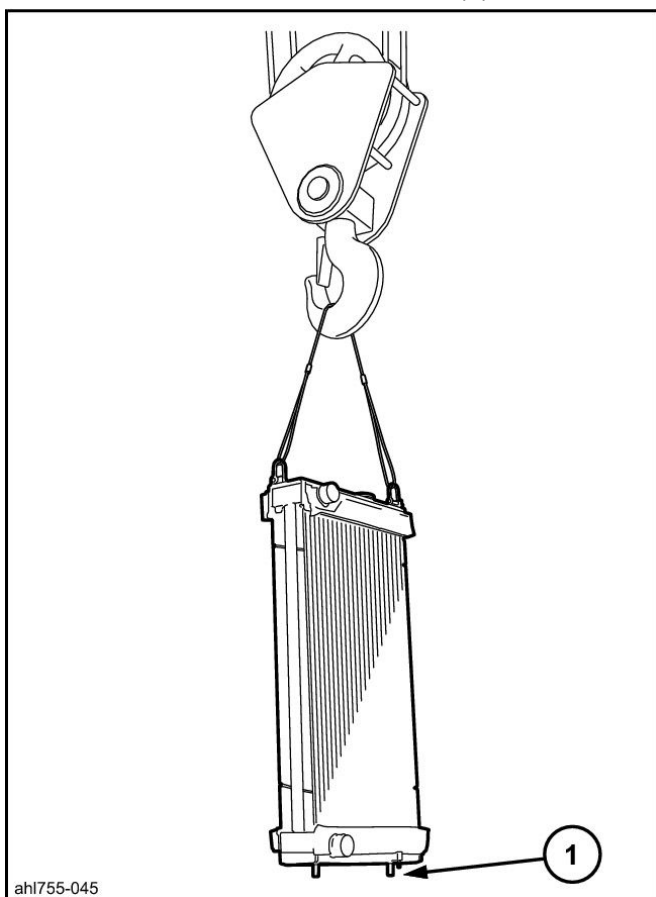

## Installation of radiator

To install, perform the reverse of the removal procedure. Tighten bolts being installed to the specified torque. For bolts for which the torque is not specified, see "Standard Torque Data for Cap Screws and Nuts". For details on the method for coolant filling, see the (Service Text Procedures for Replacing Consumable Parts • Radiator Coolant Replacement). Coolant capacity is 30 L. Finally, check that the level of coolant is correct.



**Suggest:**

**If the above button click is invalid.**

**Please download this document**

**first, and then click the above link**

**to download the complete manual.**

**Thank you so much for reading**

# Removal and installation of the fuel cooler engine inter-cooler radiator and oil cooler

## Removal and Installation of Oil Cooler

### ⚠ WARNING

- Keep away from fire.

### ⚠ CAUTION

- Be sure to stop the engine before beginning work.
- Be sure to inspect the wire rope and other lifting equipment before beginning work.
- Do not stand or pass under the suspended load.

### Items to prepare

- Wrenches (17 mm, 19 mm)
- Hexagon wrench (10 mm)
- Pliers
- Screwdriver
- Eyebolts (M12 x 2)
- Shackle (with the required lifting capacity) x 2
- Wire rope (with the required breaking load)
- Liftcrane (with the required lifting capacity)
- Caps
- Waste oil can
- Rag
- Cleaning fluid
- Wood planks, etc.

## Removal of oil cooler

1. Drain the hydraulic oil from the hydraulic oil tank. See "Draining Oil from Hydraulic Oil Tank" for details of the procedure.
2. Use a wrench (19 mm) to remove the 5 bolts (1), and then remove the under cover (2).

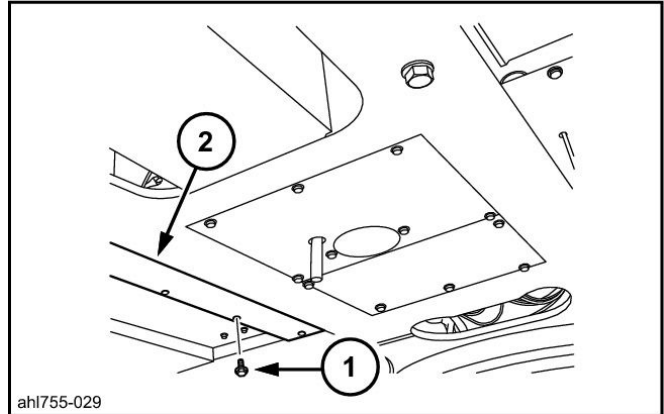

3. Prepare the waste oil can (1).

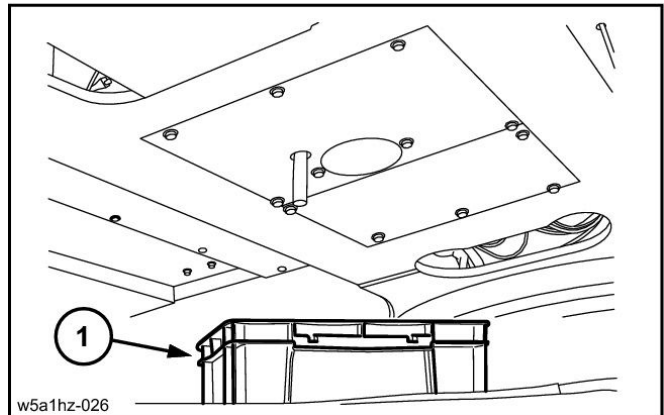

4. Remove the 4 butterfly bolts (1), and then remove the anti-insect net (2).

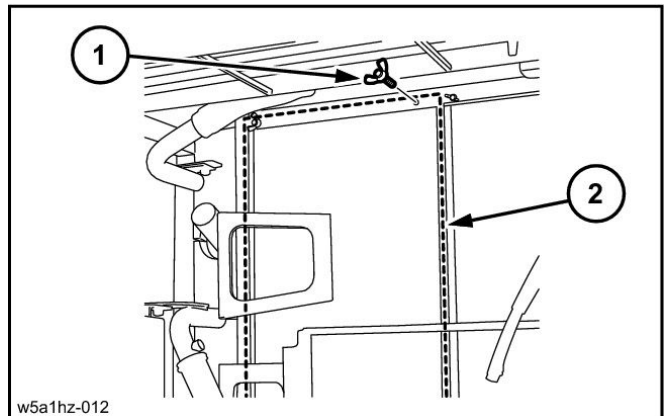

**<https://www.ebooklibonline.com>**

Hello dear friend!

Thank you very much for reading.

Enter the link into your browser.

The full manual is available for immediate download.

**<https://www.ebooklibonline.com>**