

CX350B
CX370B
Crawler Excavator

SERVICE MANUAL

Part number 47945155

English

November 2015

© 2015 CNH Industrial Italia S.p.A. All Rights Reserved.

CASE
CONSTRUCTION

CRAWLER EXCAVATOR CX350B - CX370B SERVICE MANUAL

TABLE OF CONTENTS

DIVISION/SECTION	SECTION N°	REFERENCE N°
1 GENERAL INFORMATION		
Safety, general information and standard torque data	1001	7-27691EN
General specifications and special torque setting	1002	SM350B370B1002-2EN
2 ENGINE		
Removal and installation of the engine.....	2000	New part 11/2015
Removal and installation of the fuel cooler, engine inter-cooler, radiator and oil cooler.....	2001	New part 11/2015
Removal and installation of the turbo charger	2004	New part 11/2015
Removal and installation of EGR cooler and EGR valve	2005	SM350B2005-0EN
Removal and installation of the engine hood.....	2006	SM350B2006-0EN
Engine specifications	*	
Disassembly and assembly of the engine	*	
3 FUEL SYSTEM		
Removal and installation of the fuel tank.....	3001	SM350B3001-0EN
Removal and installation of the supply pump and common rail	3004	SM350B3004-0EN
Removal and installation of the injectors	3005	SM350B3005-0EN
Fuel engine system	*	
4 ELECTRICAL SYSTEM		
Service connector kit	4000	SM350B4000-1EN
Electrical and engine functions and service support	4001	SM350B370B4001-0EN
Removal and installation of the starter motor	4004	SM350B4004-0EN
Removal and installation of the alternator	4005	SM350B4005-0EN
Electrical equipment and electrical circuit diagrams	4020	New part 11/2015
Engine error code (DTC)	4021	SM350B4021-0EN
Main body error code (DTC).....	4022	SM350B4022-0EN
Troubleshooting, 6HK1 engine	4023	SM350B4023-0EN
5 UNDERCARRIAGE		
Removal and installation of tracks	5001	SM350B5001-0EN
Rollers	5003	SM350B5003-0EN
Take-up roller	5005	SM350B5005-0EN
6 DRIVE TRAIN		
Removal and installation of the drive motor and final drive transmission.....	6001	SM350B6001-0EN
Disassembly and assembly of the drive motor and final drive transmission.....	6002	SM350B6002-0EN
Removal and installation of the swing motor and swing reduction gear	6003	SM350B6003-0EN
Disassembly and assembly of the swing reduction gear	6004	SM350B6004-0EN
7 UNDERCARRIAGE HYDRAULICS		

* Consult the Engine Service Manual

DIVISION/SECTION	SECTION N°	REFERENCE N°
8 UPPERSTRUCTURE HYDRAULICS		
Specifications, troubleshooting, checks and hydraulic pressure settings.....	8001	SM350B370B8001-0EN
Removal and installation of the hydraulic reservoir	8002	SM350B8002-0EN
Removal and installation of the main hydraulic pump.....	8003	SM350B8003-0EN
Removal and installation of the main hydraulic control valve.....	8004	SM350B8004-0EN
Removal and installation of the attachment cylinders.....	8005	SM350B8005-0EN
Removal and installation of the hydraulic swivel.....	8006	SM350B8006-0EN
Removal and installation of the pilot blocs.....	8007	SM350B8007-0EN
Disassembly and assembly of the main hydraulic pump	8010	SM350B8010-0EN
Disassembly and assembly of the main hydraulic control valve	8011	SM350B8011-0EN
Disassembly and assembly of the attachment cylinders	8012	New part 11/2015
Disassembly and assembly of the hand control levers	8013	SM130B8013-0EN
Disassembly and assembly of the foot control levers	8014	SM350B8014-0EN
Disassembly and assembly of the cushion valve.....	8016	SM130B8016-0EN
Removal and installation of the safety valve.....	8017	SM350B8017-0EN
Disassembly and assembly of the swing motor	8019	SM350B8019-0EN
Hydraulic functions	8020	SM350B370B8020-0EN
Hydraulic component functions.....	8030	SM350B370B8030-0EN
9 UPPERSTRUCTURE		
Removal and installation of the counterweight	9002	SM350B9002-0EN
Removal and installation of the boom, dipper and bucket	9003	SM350B9003-0EN
Removal and installation of the seat.....	9004	SM130B9004-0EN
Removal and installation of the cab and cab equipment	9005	SM130B9005-0EN
Air conditioner functions and troubleshooting.....	9006	SC210B9006-2EN
Air conditioning unit	9007	SM130B9007-0EN
Air conditioning components.....	9009	SM350B9009-0EN
Large size hydraulic schematics	Pocket	KSJ12480-E01
Large size electrical schematics	Pocket	KSR11440-E02

NOTE: CNHi France S.A. Company reserves the right to make changes in the specification and design of the machine without prior notice and without incurring any obligation to modify units previously sold.

The description of the models shown in this manual has been made in accordance with the technical specifications known as of the date of design of this document.

All data given in this manual is subject to production variations. Dimensions and weights are provided with approximate values and the machine fitting shown in the illustrations may not correspond with standard models. For precise information on specific machine models and versions, please contact your CASE dealer.

Reproduction or translation, even partial, is prohibited without written authorization from CNHi France SA Company.

<https://www.ebooklibonline.com>

Hello dear friend!

Thank you very much for reading.

Enter the link into your browser.

The full manual is available for immediate download.

<https://www.ebooklibonline.com>

Section 1001

**SAFETY, GENERAL INFORMATION
AND TORQUE SPECIFICATIONS**

TABLE OF CONTENTS

GENERAL INFORMATION	3
SAFETY.....	4
STANDARD TORQUE DATA FOR CAP SCREWS AND NUTS.....	6



WARNING : *This symbol is used in this manual to indicate important safety messages. Whenever you see this symbol, carefully read the message that follows, as there is a risk of serious injury.*

GENERAL INFORMATION

Cleanning

Clean all metal parts except bearings, in a suitable cleaning solvent or by steam cleaning. Do not use caustic soda for steam cleaning. After cleaning, dry and put oil on all parts. Clean oil passages with compressed air. Clean bearings in a suitable cleaning solvent, dry the bearings completely and put oil on the bearings.

Inspection

Check all parts when the parts are disassembled. Replace all parts that have wear or damage. Small scoring or grooves can be removed with a hone or crocus cloth. Complete a visual inspection for indications of wear, pitting and the replacement of parts necessary to prevent early failures.

Bearings

Check bearings for easy action. If bearings have a loose fit or rough action replace the bearing. Wash bearings with a suitable cleaning solvent and permit to air dry. **DO NOT DRY BEARINGS WITH COMPRESSED AIR.**

Needle bearings

Before you press needle bearings in a bore always remove any metal protrusions in the bore or edge of the bore. Before you press bearings into position put petroleum jelly on the inside and outside diameter of the bearings.

Gears

Check all gears for wear and damage. Replace gears that have wear or damage.

Oil seals, O-rings and gaskets

Always install new oil seals, O-rings and gaskets. Put petroleum jelly on seals and O-rings.

Shafts

Check all shafts that have wear or damage. Check the bearing and oil seal surfaces of the shafts for damage.

Service parts

Always install genuine Case service parts. When ordering refer to the Parts Catalog for the correct part number of the genuine Case replacement items. Failures due to the use of other than genuine Case replacement parts are not covered by warranty.

Lubrication

Only use the oils and lubricants specified in the Operator's or Service Manuals. Failures due to the use of non-specified oils and lubricants are not covered by warranty.

SAFETY



This symbol means ATTENTION! BECOME ALERT! YOUR SAFETY IS INVOLVED. The message that follows the symbol contains important information about safety. Carefully read the message. Make sure you fully understand the causes of possible injury or death.

To prevent injury always follow the Warning, Caution and Danger notes in this section and throughout the manual.

Put the warning tag shown below on the key for the keyswitch when servicing or repairing the machine. One warning tag is supplied with each machine. Additional tags Part Number 331-4614 are available from your service parts supplier



WARNING: *Read the operator's manual to familiarize yourself with the correct control functions.*



WARNING: *Operate the machine and equipment controls from the seat position only. Any other method could result in serious injury.*



WARNING: *This is a one man machine, no riders allowed.*



WARNING: *Before starting engine, study Operator's Manual safety messages. Read all safety signs on machine. Clear the area of other persons. Learn and practice safe use of controls before operating.*

It is your responsibility to understand and follow manufacturers instructions on machine operation, service and to observe pertinent laws and regulations. Operator's and Service Manuals may be obtained from your Case dealer.



WARNING: *If you wear clothing that is too loose or do not use the correct safety equipment for your job, you can be injured. Always wear clothing that will not catch on objects. Extra safety equipment that can be required includes hard hat, safety shoes, ear protection, eye or face protection, heavy gloves and reflector clothing.*



WARNING: *When working in the area of the fan belt with the engine running, avoid loose clothing if possible, and use extreme caution.*



WARNING: *When doing checks and tests on the equipment hydraulics, follow the procedures as they are written. DO NOT change the procedure.*



WARNING: *When putting the hydraulic cylinders on this machine through the necessary cycles to check operation or to remove air from a circuit, make sure all people are out of the way.*



WARNING: Use insulated gloves or mittens when working with hot parts.



WARNING: Lower all attachments to the ground or use stands to safely support the attachments before you do any maintenance or service.



WARNING: Pin sized and smaller streams of hydraulic oil under pressure can penetrate the skin and result in serious infection. If hydraulic oil under pressure does penetrate the skin, seek medical treatment immediately. Maintain all hoses and tubes in good condition. Make sure all connections are tight. Make a replacement of any tube or hose that is damaged or thought to be damaged. **DO NOT** use your hand to check for leaks, use a piece of cardboard or wood.



WARNING: When removing hardened pins such as a pivot pin, or a hardened shaft, use a soft head (brass or bronze) hammer or use a driver made from brass or bronze and a steel head hammer.



WARNING: When using a hammer to remove and install pivot pins or separate parts using compressed air or using a grinder, wear eye protection that completely encloses the eyes (approved goggles or other approved eye protectors).



WARNING: Use suitable floor (service) jacks or chain hoist to raise wheels or tracks off the floor. Always block machine in place with suitable safety stands.



WARNING: When servicing or repairing the machine, keep the shop floor and operator's compartment and steps free of oil, water, grease, tools, etc. Use an oil absorbing material and/or shop cloths as required. Use safe practices at all times.



WARNING: Some components of this machine are very heavy. Use suitable lifting equipment or additional help as instructed in this Service Manual.



WARNING: Engine exhaust fumes can cause death. If it is necessary to start the engine in a closed place, remove the exhaust fumes from the area with an exhaust pipe extension. Open the doors and get outside air into the area.



WARNING: When the battery electrolyte is frozen, the battery can explode if (1), you try to charge the battery, or (2), you try to jump start and run the engine. To prevent the battery electrolyte from freezing, try to keep the battery at full charge. If you do not follow these instructions, you or others in the area can be injured.

Section

2000

REMOVAL AND INSTALLATION OF THE ENGINE

TABLE OF CONTENTS

REMOVAL AND INSTALLATION OF THE ENGINE ASSEMBLY	3
REMOVAL OF THE ENGINE.....	3
INSTALLATION OF THE ENGINE	14

REMOVAL AND INSTALLATION OF THE ENGINE ASSEMBLY

Caution:	<p>Keep away from fire. Be sure to release hydraulic pressure before beginning work. The air conditioner circuit is filled with high-pressure gas, so there is the danger of gas splaying out when loosening lines. Do not use open flames and do not allow sparks near the battery.</p>
-----------------	---

Caution:	<p>Be sure to stop the engine before beginning work. Be sure to inspect the wire rope and other lifting equipment before beginning work. Do not stand or pass under the suspended load.</p>
-----------------	---

1 Removal of the engine

- [1] Drain the engine oil.
(For details, see "Operator's Manual".)
- [2] Drain the coolant from the radiator.
(For details, see "Operator's Manual".)
- [3] Remove the engine hood.
(For details, see "Removal and Installation of Engine Hood".)
- [4] Remove the pump.
(For details, see "Removal and Installation of Pump")
- [5] Disassemble the retaining screws (1).

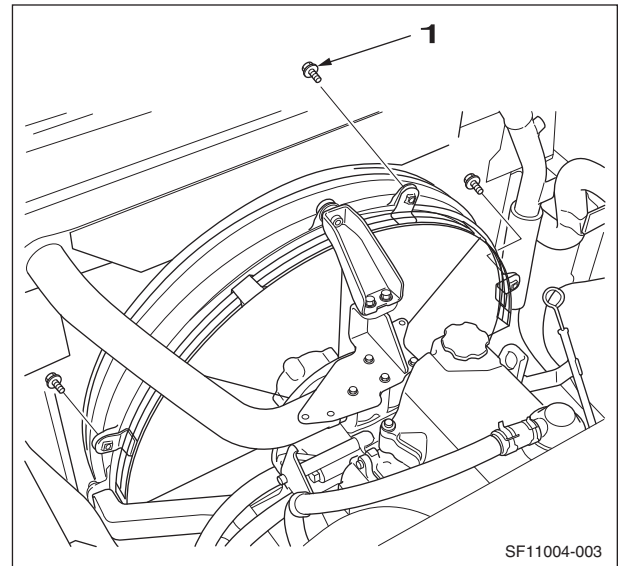

- [6] Remove the 3 bolts (2), and then remove the bracket (3).

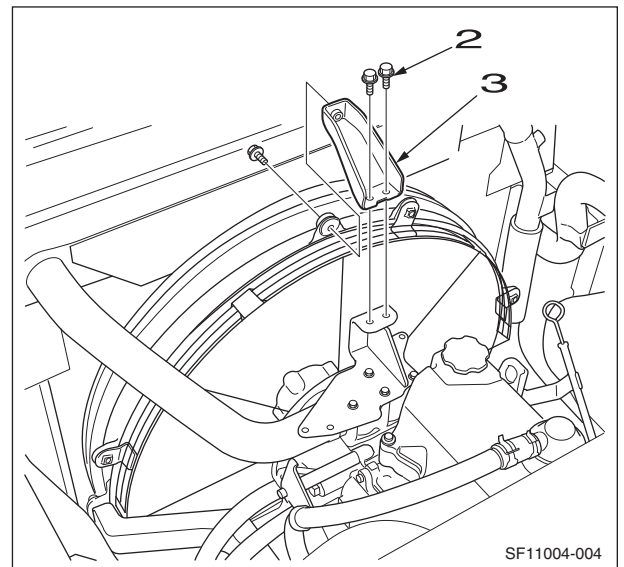

[7] Remove the fan guard (4).

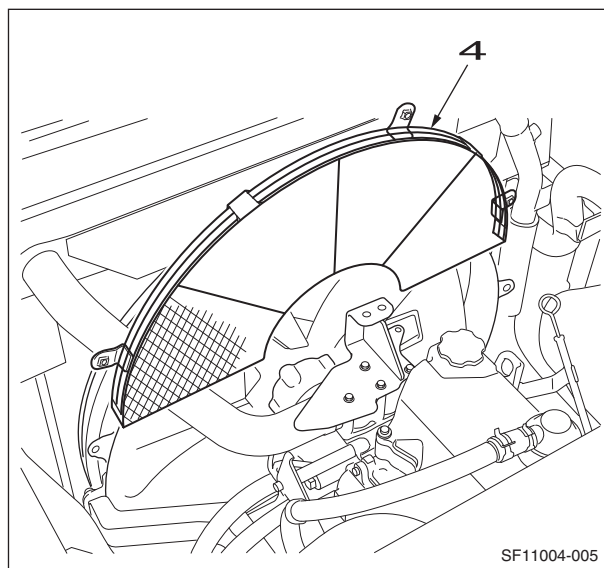

[8] Remove the 4 bolts, and then remove the fan guide rubber (5).

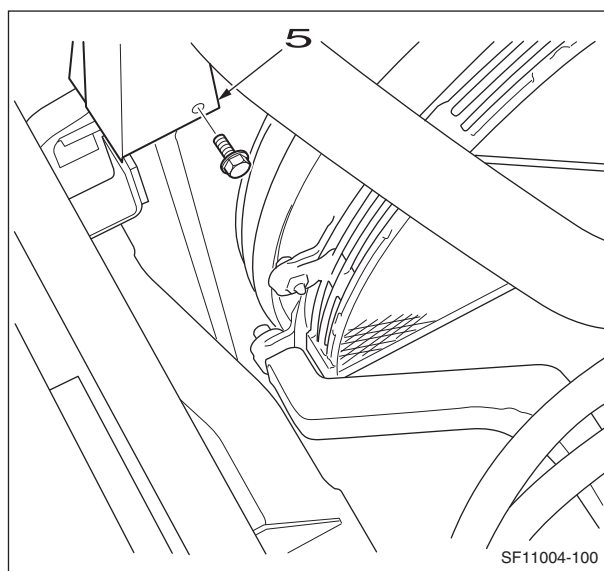

[9] Loosen the hoseband (6), and then remove the upper hose (7) from the radiator.

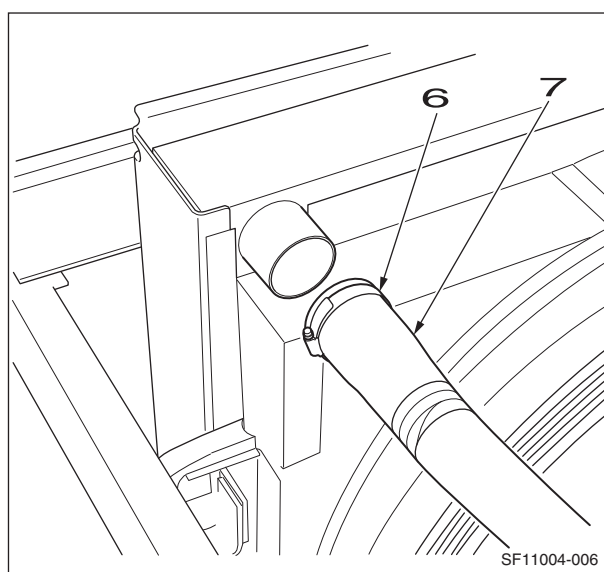

[10] Loosen the hoseband (6), and then remove the lower hose (8) from the radiator.

- Use caps to cover the radiator and hoses and prevent the entry of water, dust or dirt.
- Before removing the radiator hoses, completely drain the coolant.

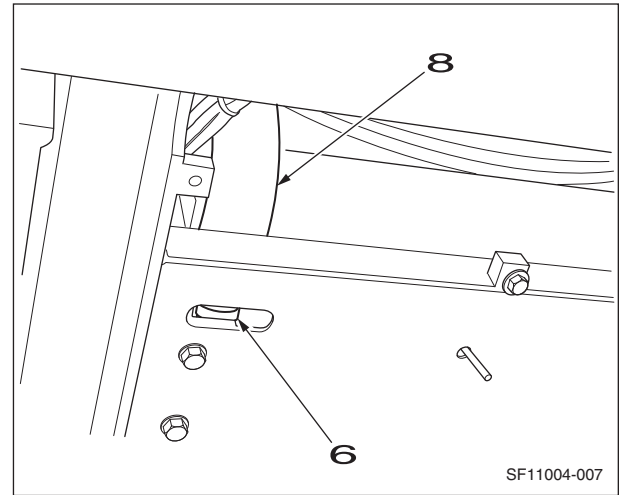

[11] Loosen the line bolts (9) in 2 locations, and then remove the 2 lines (10) and (11) from the compressor.

- Always remove the low-pressure pipe (10) first.
- Attach caps or plugs to the compressor and pipes to prevent any entry of water, dust or dirt.

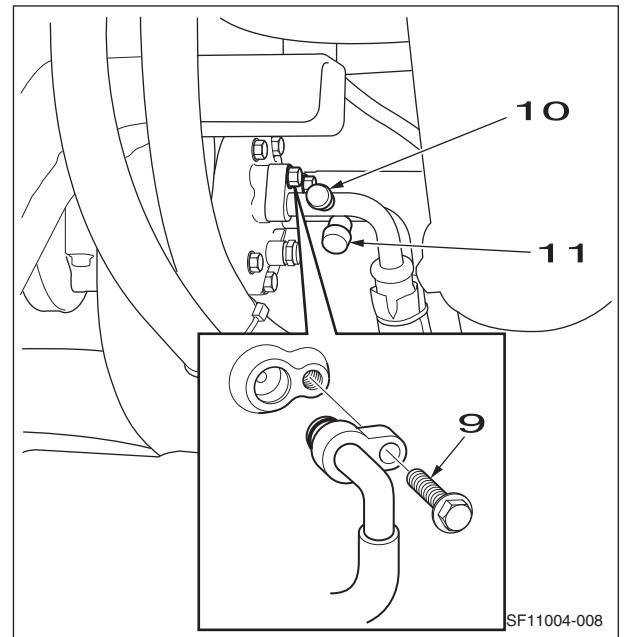

[12] Remove the 2 bolts (1).

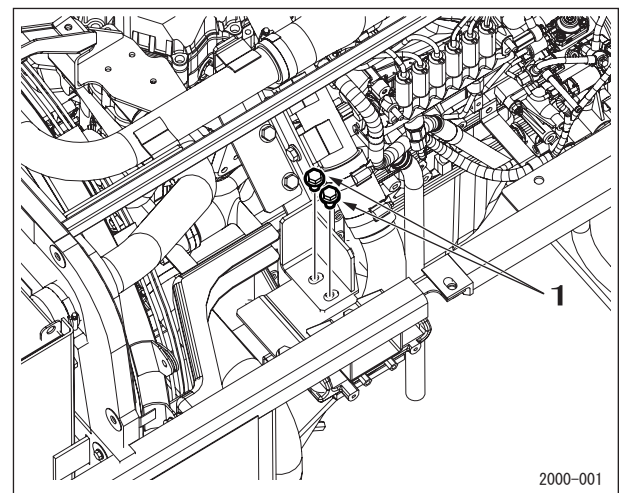

[13] Loosen the hoseband (1) on the inter cooler, and then remove the hose (2).

- Use caps to cover the pipe and hose and prevent the entry of water, dust or dirt
- Tightening torque for hoseband: 8.8 - 9.8 Nm

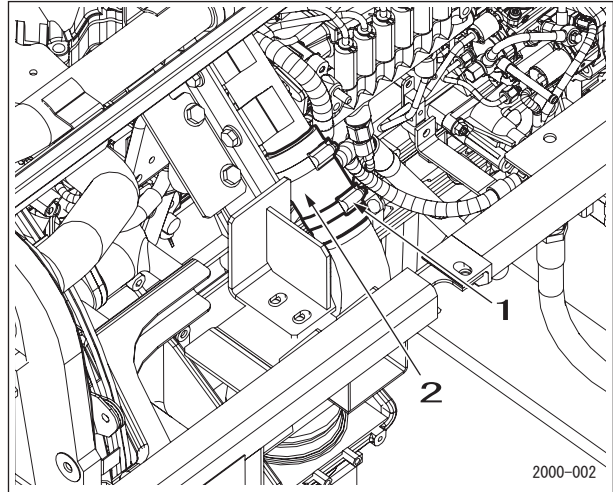

[14] Remove the bolts (14), and then remove the under cover (15).

- Use caution when removing as the parts are heavy.

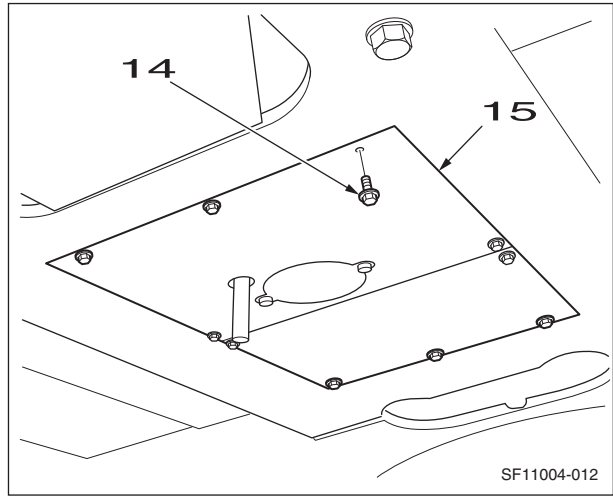

[15] Prepare a waste oil can (16). As the engine oil hose will be removed, first drain the engine oil.

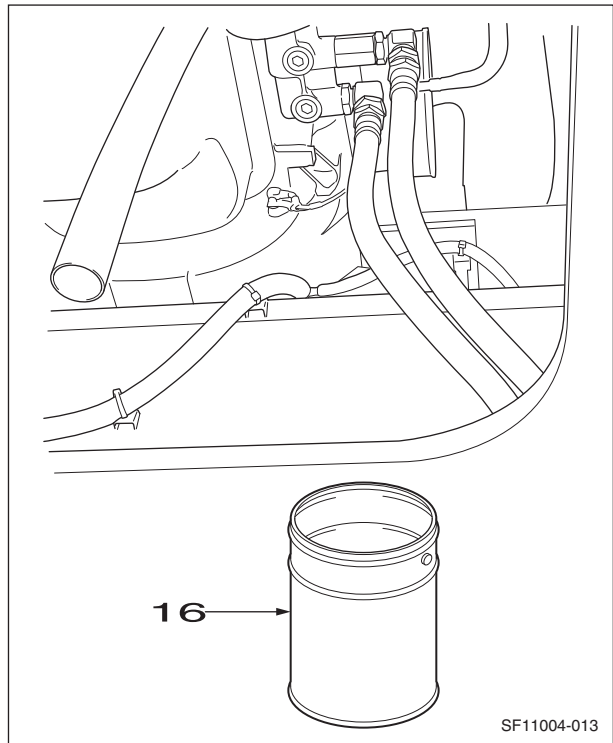

[16] Remove the hoses (17).

- Mark the engine and hoses so that the connectors match at the time of assembly.
- Attach caps or plugs to the engine and hoses to prevent any entry of water, dust or dirt.
- Clean the engine and hoses by spraying with a parts cleaner to prevent scratches and prevent dirt from accumulating on the connectors.

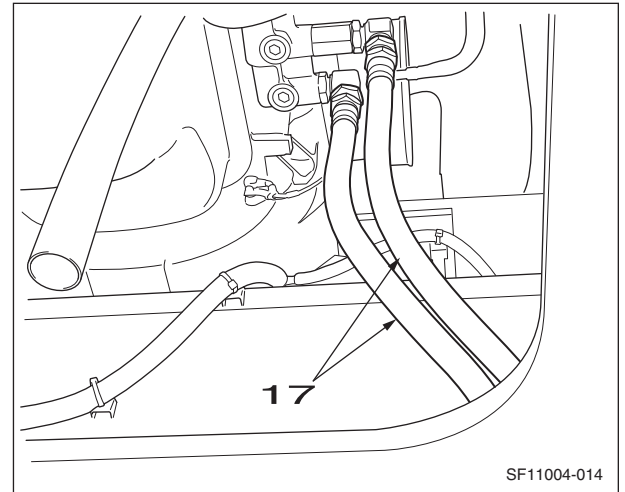

[17] Remove the bolt (18), and then remove the battery cable (19) on the negative side.

- When removing the terminal and harness, secure them so that do not interfere with the frame. Also, cover with a rubber cap to protect against sparks.

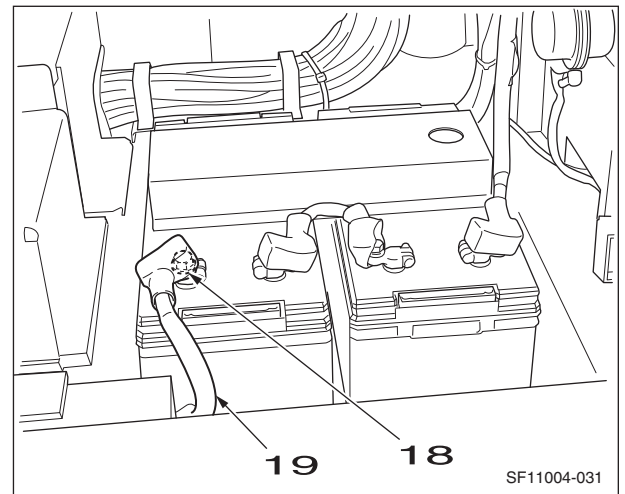

[18] Remove the bolts (20), and then remove the under cover (21).

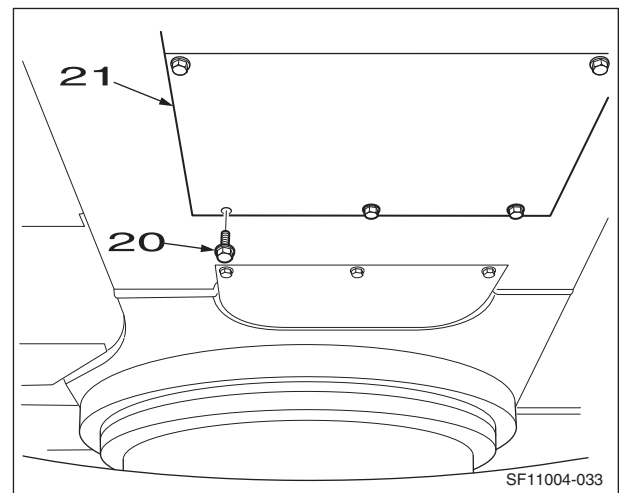

[19] Remove the nuts (22), and then remove the wire (23) from the starter motor.

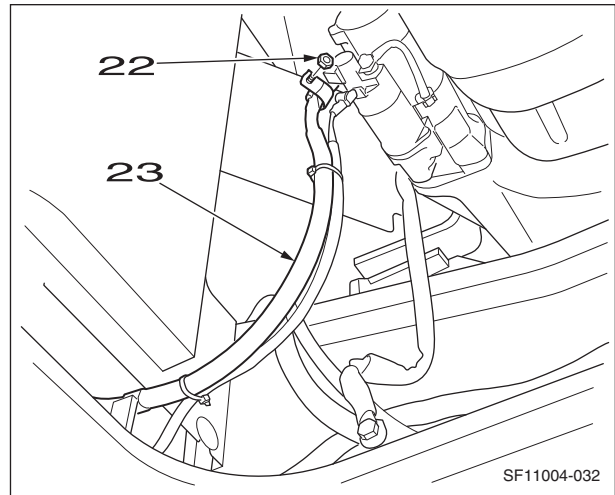

[20] Remove the hoseband (24), and then remove the fuel hose (25).

- Attach caps or plugs to the engine and hoses to prevent any entry of water, dust or dirt.

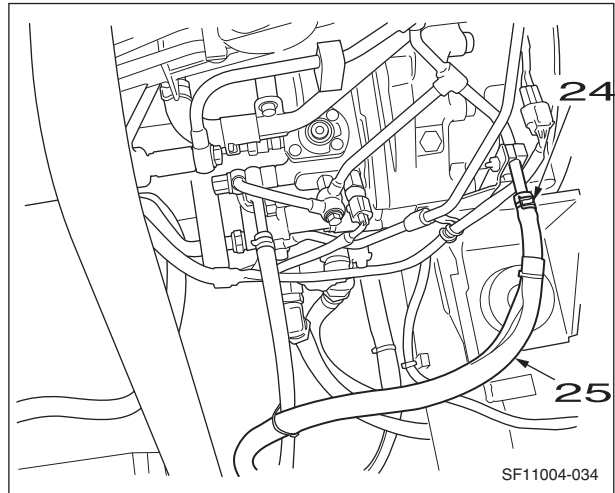

[21] Remove the hoseband (26), and then remove the fuel hose (27).

- Attach caps or plugs to the engine and hoses to prevent any entry of water, dust or dirt.

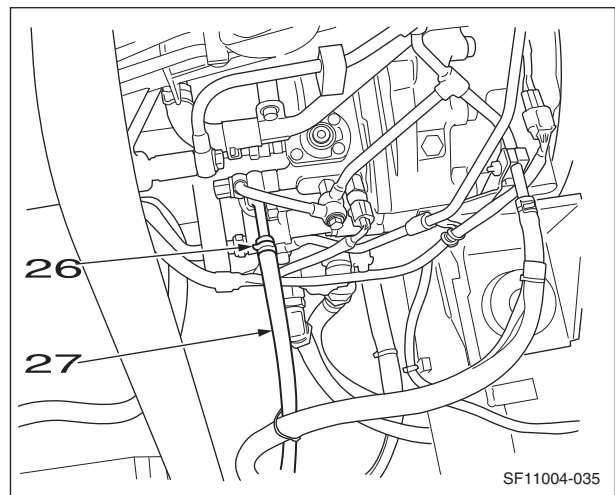

[22] Disassemble the retaining screws (28), and then remove the box cover (29).

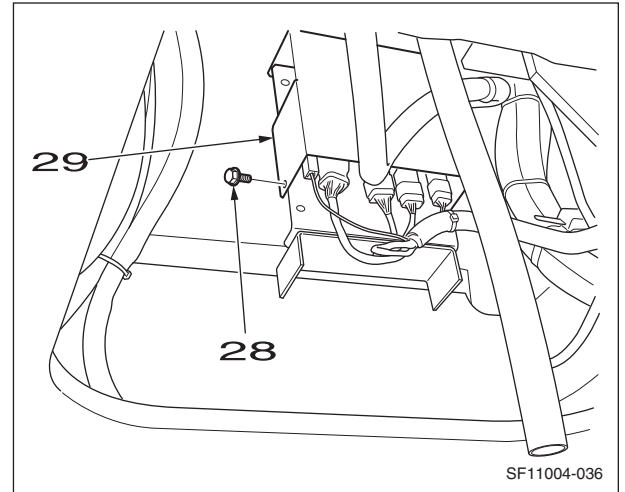

[23] Remove the connectors (30) in the box.

- After tying the connectors together, put them in a plastic bag.

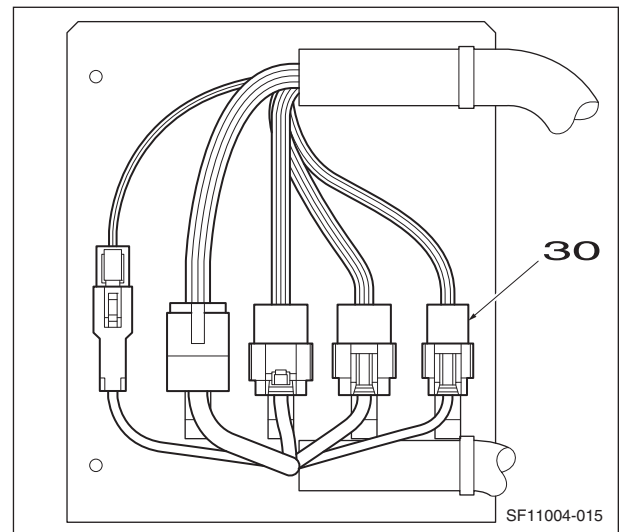

[24] Loosen the hoseband (31), and then remove the heater hose (32).

- Attach caps or plugs to the engine and hoses to prevent any entry of water, dust or dirt.

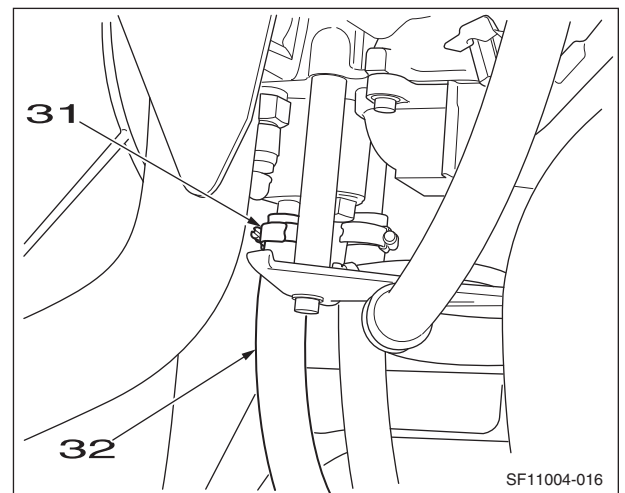

[25] Loosen the hoseband (33), and then remove the heater hose (34).

- Attach caps or plugs to the engine and hoses to prevent any entry of water, dust or dirt.

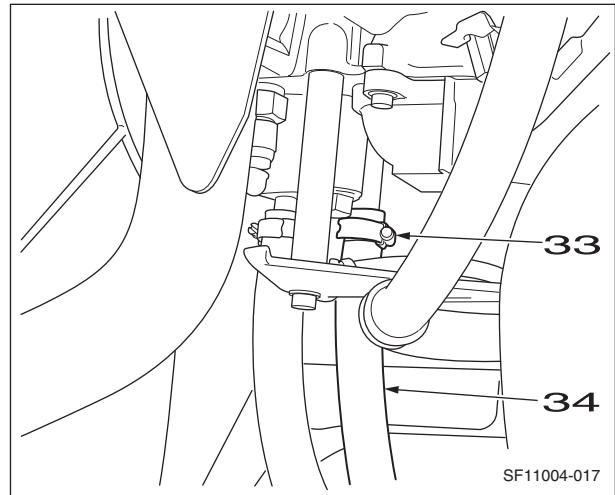

[26] Loosen the hoseband (35), and then remove the radiator hose (36).

- Use caps to cover the line and hose and prevent the entry of water, dust or dirt.

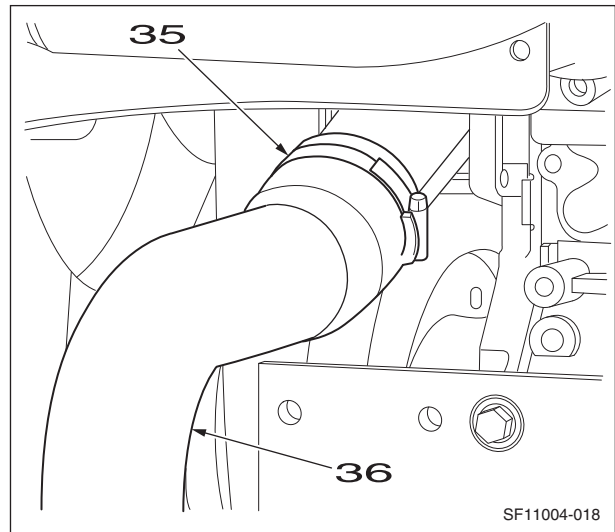

[27] Remove the 3 bolts (1).

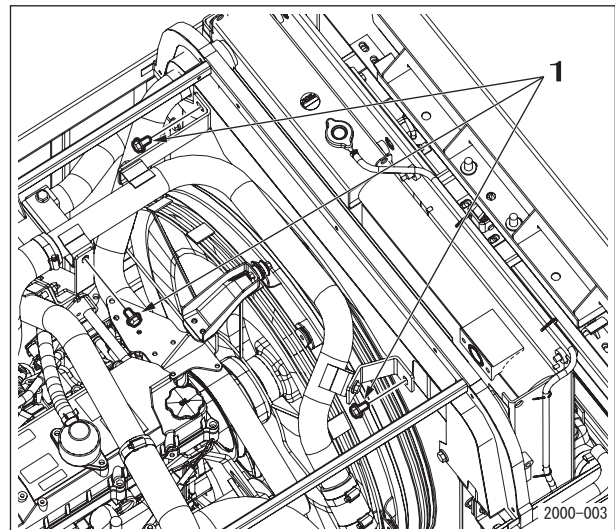

[28] Loosen the hosebands (1), and then remove the air pipe (2).

- Use caps to cover the line and hose and prevent the entry of water, dust or dirt.
- Tightening torque for hoseband: 8.8 - 9.8 Nm

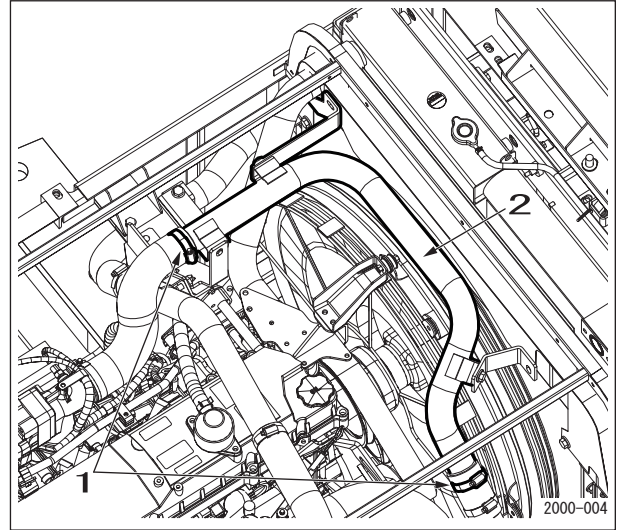

[29] Loosen the hosebands (1) (2), and then remove the air hose (3).

- Use caps to cover the line and hose and prevent the entry of water, dust or dirt.
- Tightening torque for hoseband (1): 8.8 - 9.8 Nm
- Tightening torque for hoseband (2): 5.0 - 6.0 Nm

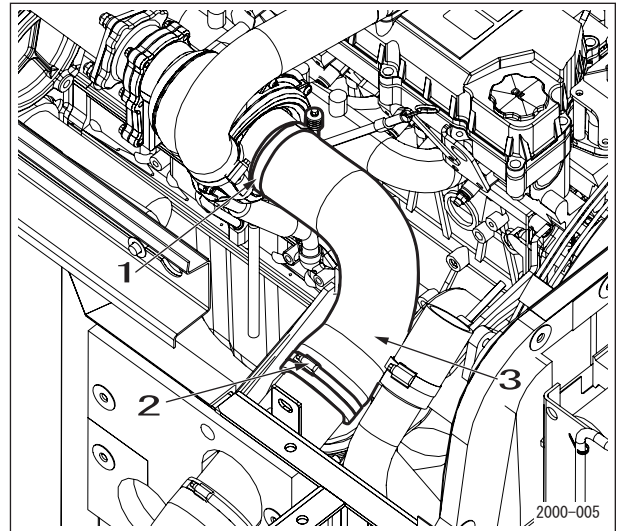

[30] Remove the connector (41) from the alternator.

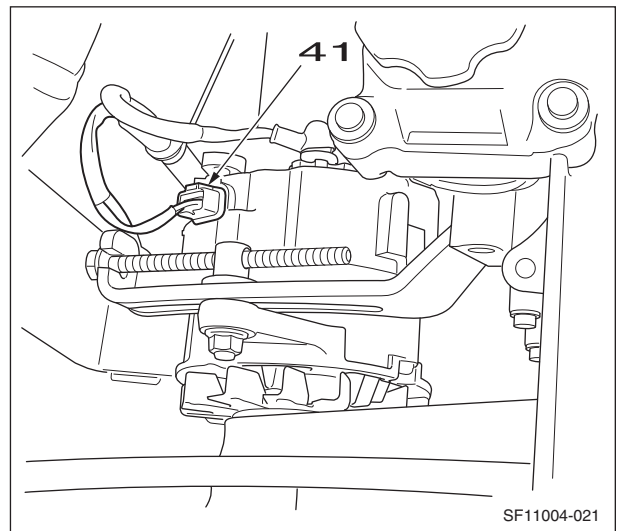

2000-12

[31] Remove the cap (42), remove the nut (44), and then remove the wire (43) from the alternator.

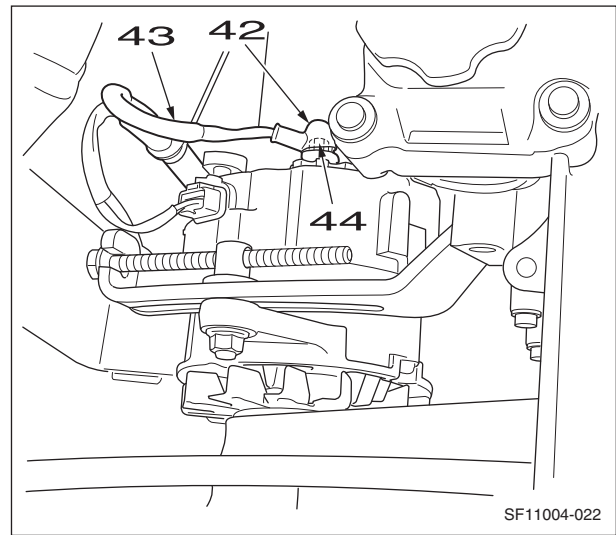

[32] Connect the 2 shackles (1), and then use the wires and crane to secure the engine.

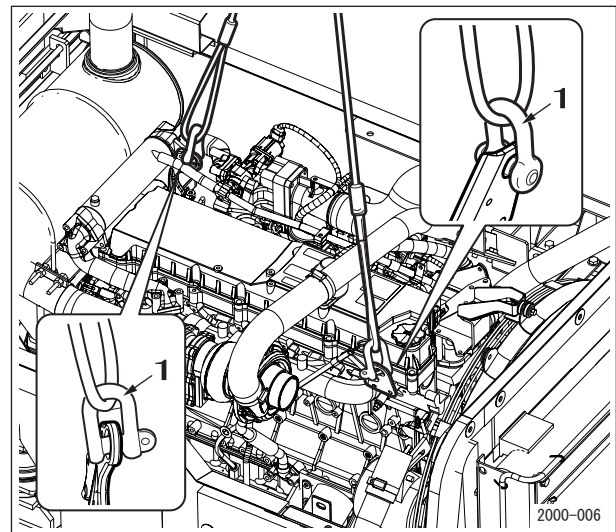

[33] Disassemble the retaining screws (1) (47) from the mount.

- Tightening torque for retaining screw (1) (47): 324 - 373 Nm

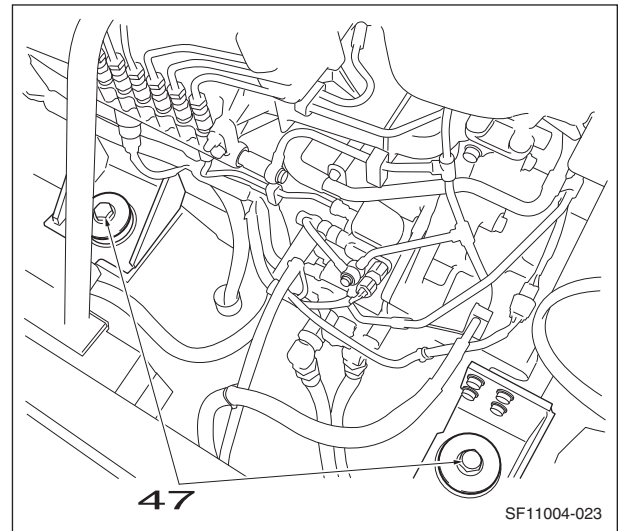
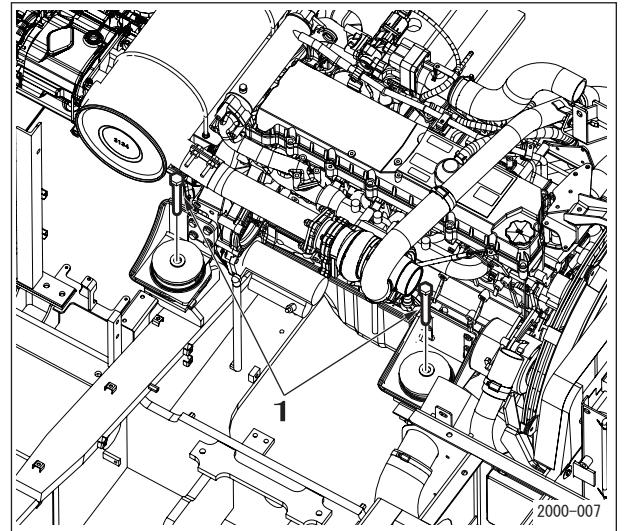

[34] Use the wires and crane to lift the engine.

[35] Thoroughly check that the location is safe before lowering the engine on wood planks, etc.

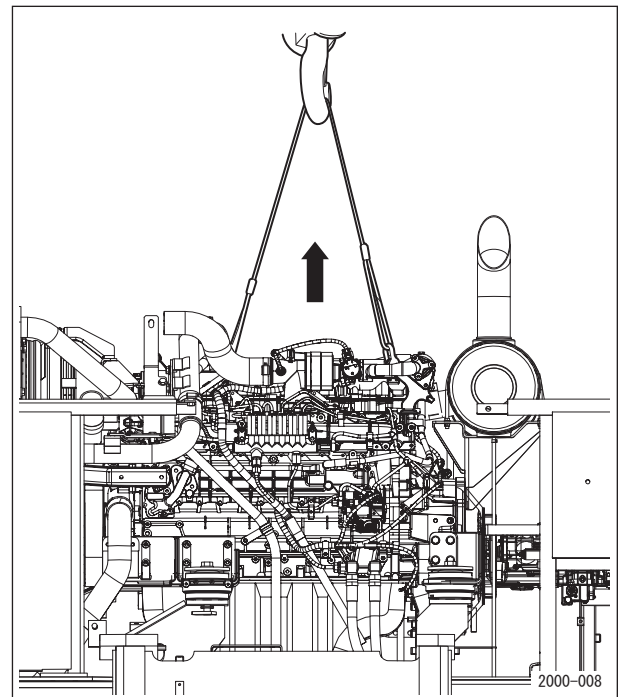

2 Installation of the engine

[1] To install the engine, perform the reverse of the removal procedure.

After installing the engine, resupply coolant and engine oil, perform fuel line air bleeding, and perform filling for the air conditioner gas.

For details, see the individual explanations for each procedure.

[2] Run the engine at no-load idling and check for any water or oil leaks.

[3] Attach the hydraulic pump, covers, and counterweight.

For details, see the individual explanations for each procedure.

REMOVAL AND INSTALLATION OF FUEL COOLER

Caution:

Be sure to stop the engine before beginning work.
As the fuel hose will be removed, strictly prohibit open flames.

1 Removal of fuel cooler

- [1] Mark the fuel cooler (5) and hoses so that the connectors match at the time of assembly.
Loosen the hosebands (3) and (4), and then remove the hoses (1) and (2).
- Fuel will spill out, so place a drip pan directly below the area.
 - Attach caps or plugs to the fuel cooler and hoses to prevent any entry of water, dust or dirt.

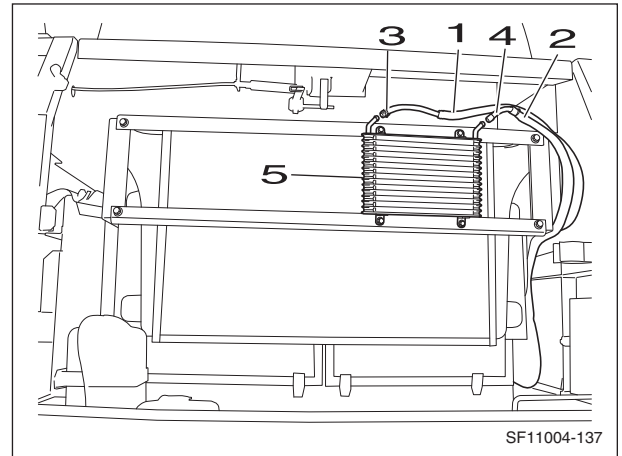

- [2] Disassemble the retaining screws (6), and then remove the fuel cooler unit (5).

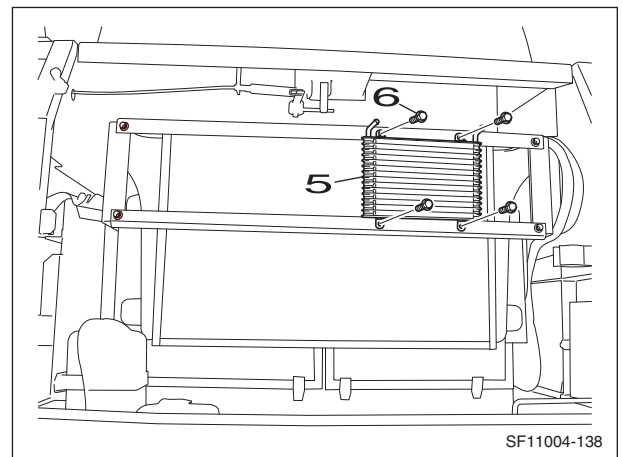

2 Installation the fuel cooler

Perform the reverse of the removal procedure.

- After connecting the hoses, carefully check for any fuel leaks.

REMOVAL AND INSTALLATION OF INTER COOLER

Caution:

Be sure to stop the engine before beginning work.
As the fuel hose will be removed, strictly prohibit open flames.

1 Removal of inter cooler

- [1] Remove the fuel cooler.
(For details, see "Removal and Installation of Fuel Cooler")
- [2] Use a wrench (17 mm) to remove the 4 bolts (1), and then remove the bracket (2) from the fuel cooler.

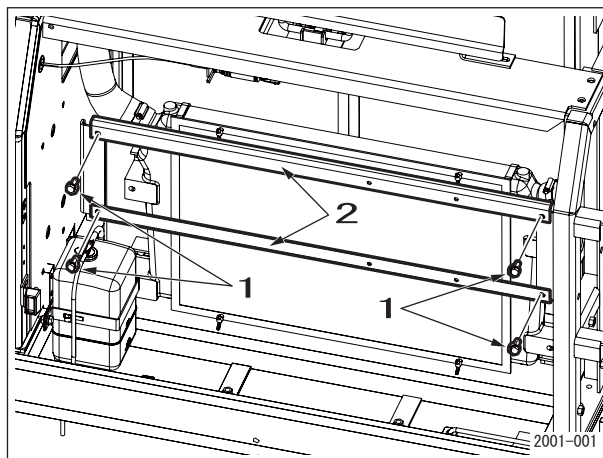

- [3] Loosen the hosebands (1) in the two locations, and then remove the two hoses (2) and (3).
- Use caps to cover the inter cooler and hoses to prevent the entry of water, dust or dirt.

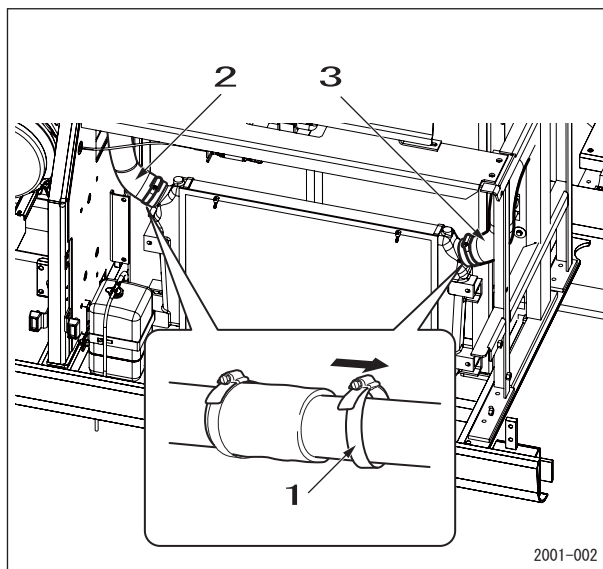

- [4] Use a wrench (17 mm) to remove the 4 bolts (1), and then remove the inter cooler (2).

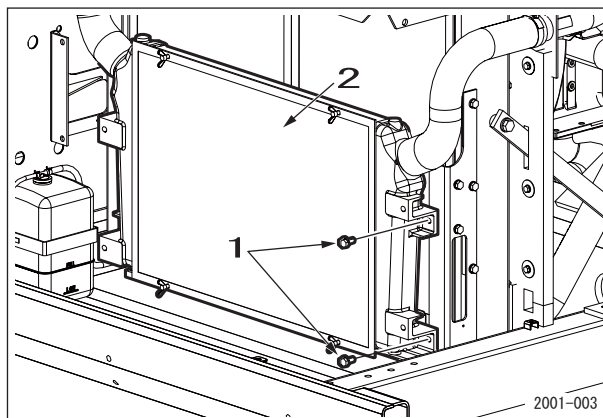

2 Installation of inter cooler

Perform the reverse of the removal procedure.
Check for any air leaks.

REMOVAL AND INSTALLATION OF RADIATOR

Caution:	Do not remove the radiator cap when the radiator coolant temperature is high. Hot liquid could spray out.
-----------------	---

Caution:	<p>Be sure to release hydraulic pressure before beginning work.</p> <p>Be sure to stop the engine before beginning work.</p> <p>Be sure to inspect the wire rope and other lifting equipment before beginning work.</p> <p>Do not stand or pass under the suspended load.</p>
-----------------	---

1 Removal of radiator

- [1] Disassemble the retaining screws (1), and then remove the under cover (2).

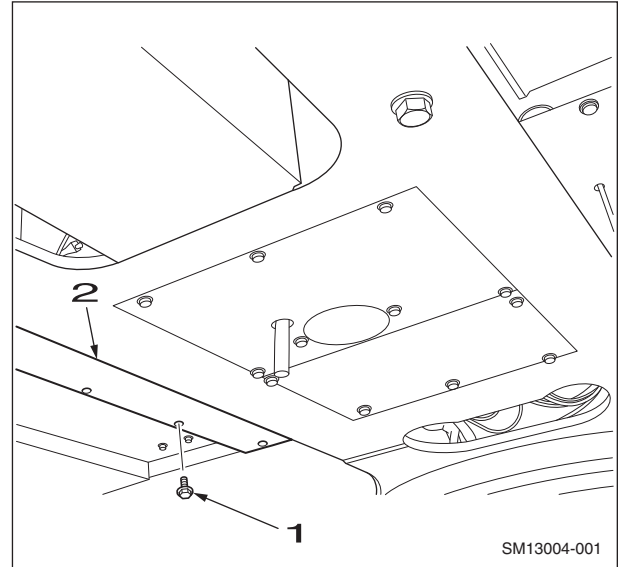

- [2] Install the drain hose (3), and then prepare the drain tank (4).

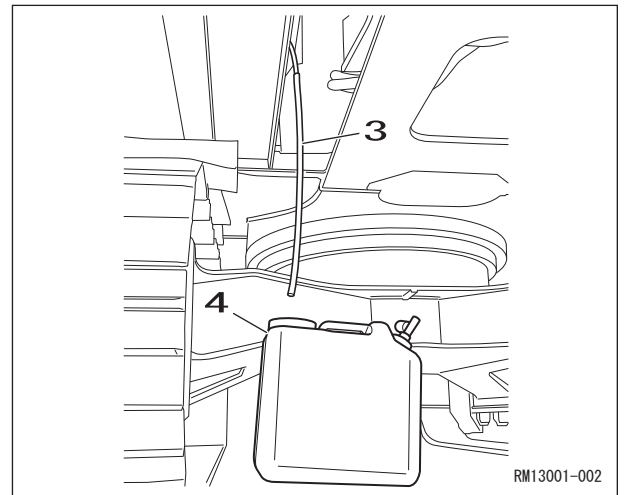

[3] To make it easier to drain the coolant, remove the radiator cap (5).

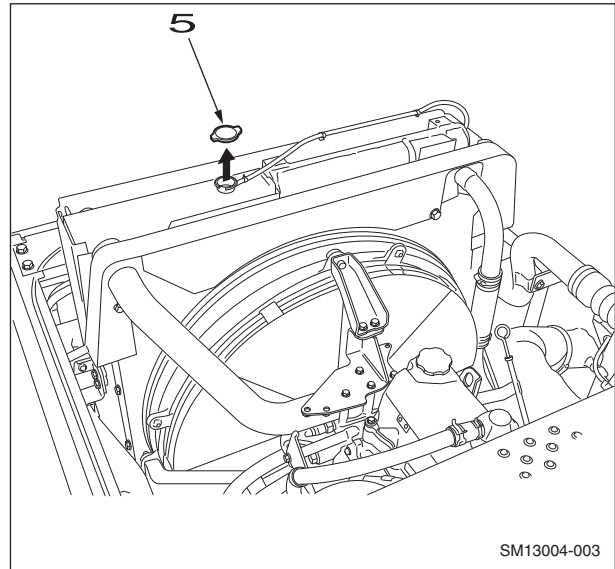

[4] Loosen the drain plug (6), and then drain the coolant.

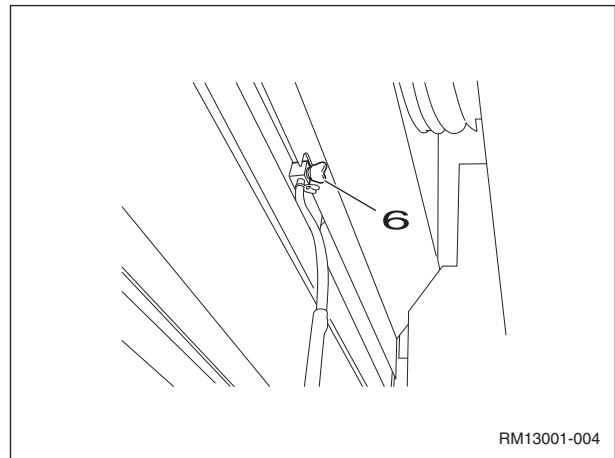

[5] Loosen the hosebands (1) (2).

- Use caps to cover the pipe and hose and prevent the entry of water, dust or dirt.
- Tightening torque for hoseband (1): 8.8 - 9.8 Nm.

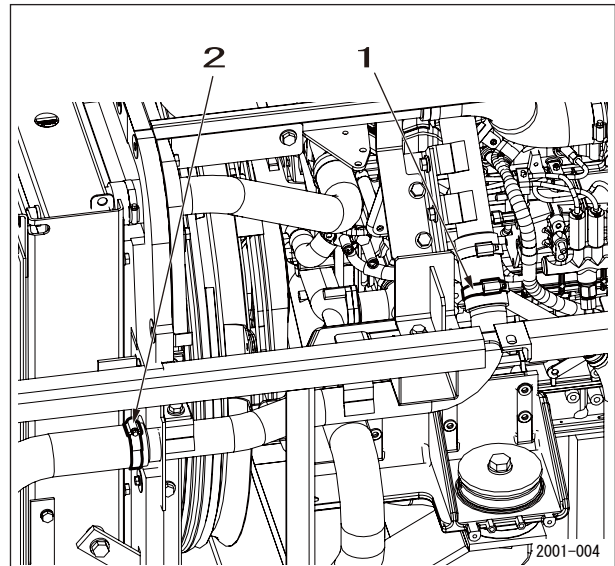

[6] Use a wrench (19 mm) to remove the 2 bolts (1), and then remove the pipe (2).

- Use caps to cover the pipe and hose and prevent the entry of water, dust or dirt.

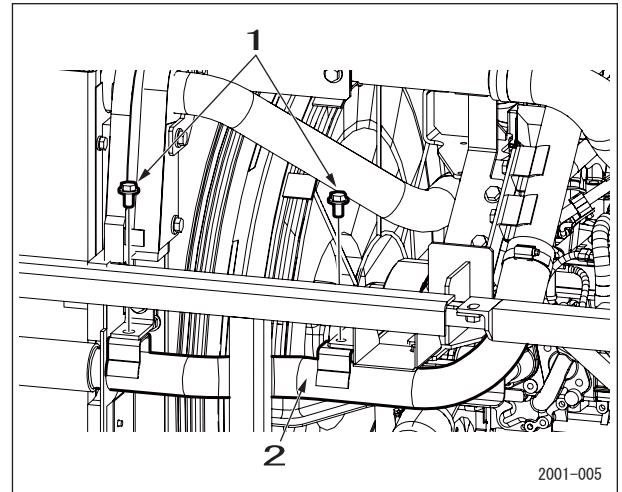

[7] Use a wrench (19 mm) to remove the 5 bolts (1), and then remove the seal bracket (2).

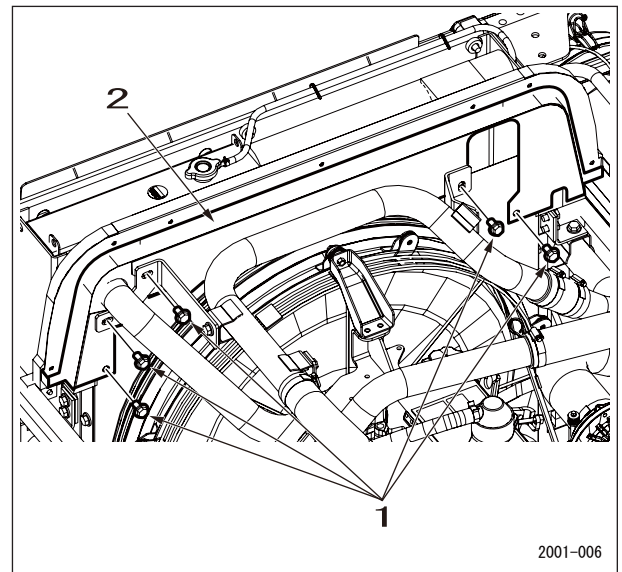

[8] Use a box wrench (17 mm) to remove the 6 bolts (12) from the radiator cover.

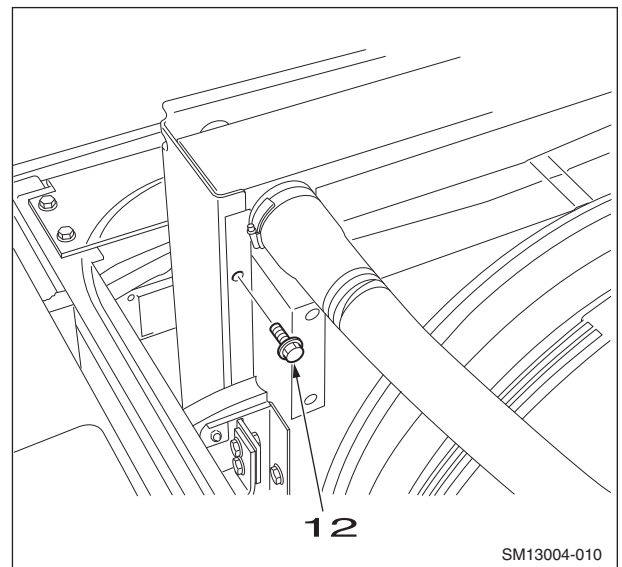

2001-8

- [9] Loosen the hosebands (13), and then remove the upper hose (14) and the lower hose (15) from the radiator.
- Use caps to cover the radiator and hoses and prevent the entry of water, dust or dirt.

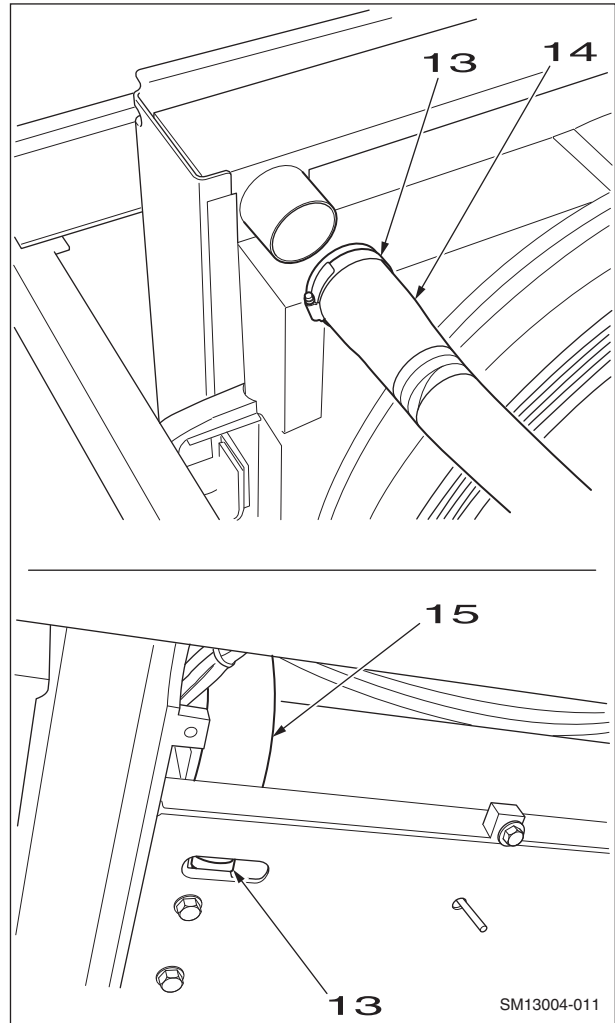

- [10] Remove the drain plug (16), Loosen the hoseband (17), and then remove the hose (18).

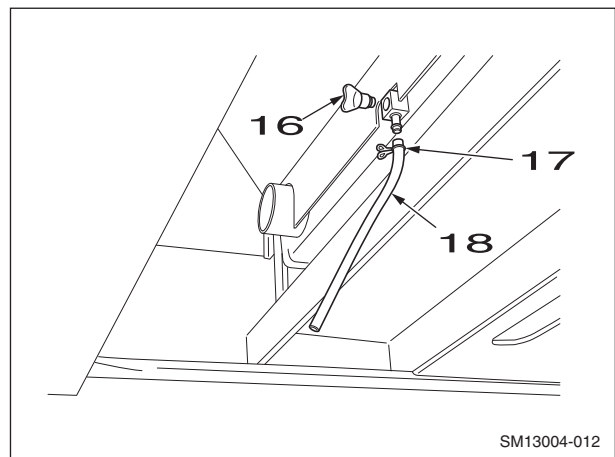

[11] Loosen the hoseband (20), and then remove the hose (19) from the radiator cap.

- Attach caps or plugs to the hoses to prevent any entry of water, dust or dirt.

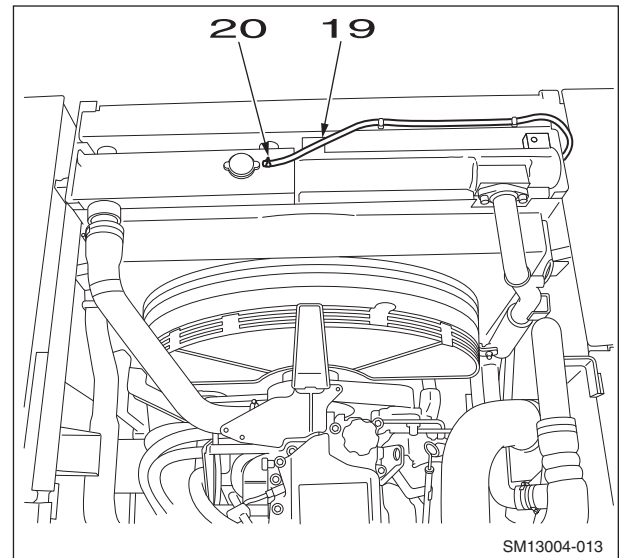

[12] Use a wrench (14 mm) to remove the 3 bolts (21).

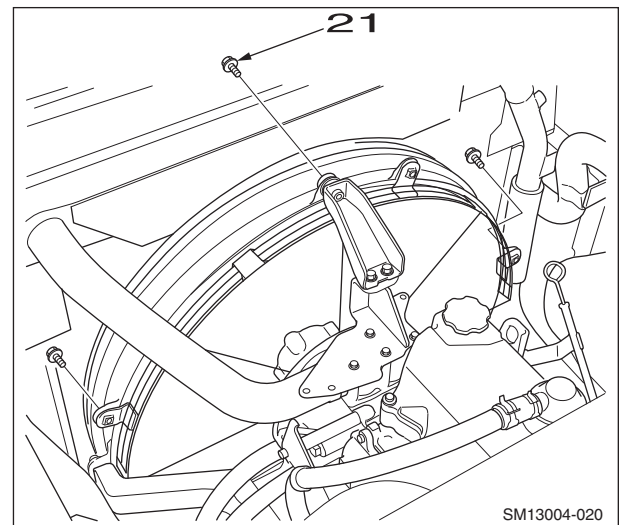

[13] Use a wrench (14 mm) to remove the bolts (22), and then remove the bracket (23).

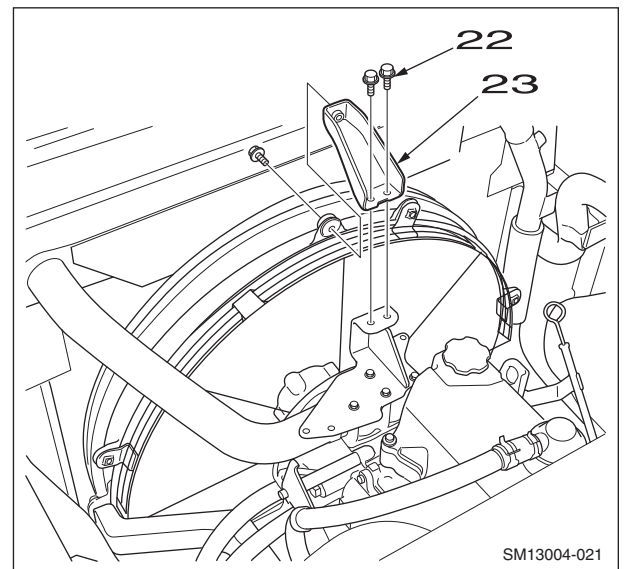



Suggest:

If the above button click is invalid.

Please download this document

first, and then click the above link

to download the complete manual.

Thank you so much for reading

2001-10

[14] Remove the fan guard (24).

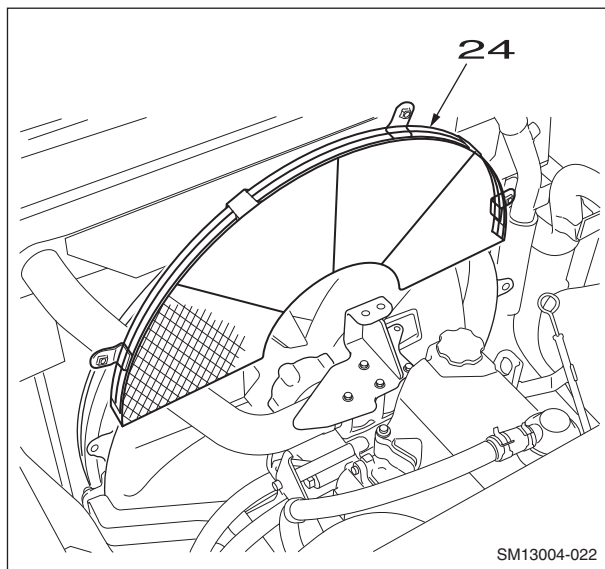

[15] Remove the fan guide rubber (25).

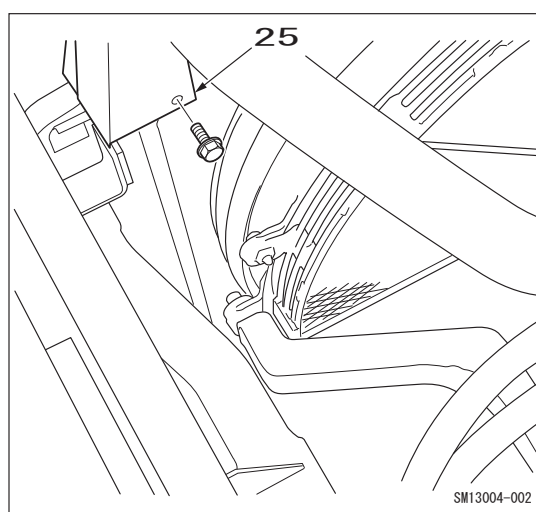

[16] Remove the 2 butterfly bolts (26), and then remove the front anti-insect net (27).

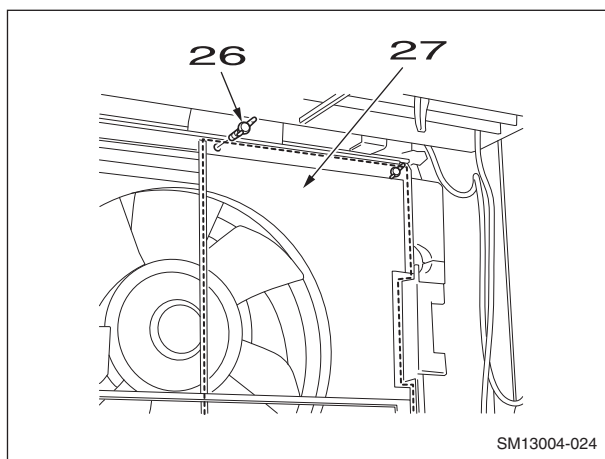

<https://www.ebooklibonline.com>

Hello dear friend!

Thank you very much for reading.

Enter the link into your browser.

The full manual is available for immediate download.

<https://www.ebooklibonline.com>