

# CX330 and CX350 Crawler Excavators

## Table of Contents

DIVISION/SECTION	SECTION N°	REFERENCE N°
<b>1 GENERAL INFORMATION</b>		
Safety, general information and standard torque data .....	1001	7-27690GB
General specifications and special torque setting.....	1002	9-36450GB
<b>2 ENGINE</b>		
Removal and installation of the engine .....	2000	9-43540GB
Radiator and oil-cooler .....	2001	9-43480GB
Engine specifications .....	*	
Disassembly and assembly of the engine.....	*	
<b>3 FUEL SYSTEM</b>		
Fuel tank .....	3001	9-43470GB
Fuel engine system.....	*	
<b>4 ELECTRICAL SYSTEM</b>		
Electrical system, electrical and electronic troubleshooting.....	4001	9-40950GB
Inspection and maintenance of batteries and connecting a booster battery ....	4002	9-43460GB
Main and engine electronic control boxes.....	4003	9-43450GB
<b>5 UNDERCARRIAGE</b>		
Removal and installation of tracks .....	5001	9-42910GB
Rollers.....	5003	9-42920GB
Sprocket.....	5004	9-36890GB
Idler wheel and tension shock absorber .....	5005	9-43000GB
<b>6 DRIVE TRAIN</b>		
Drive motor and final drive transmission removal and installation .....	6001	9-43140GB
Swing reduction gear, removal and installation.....	6003	9-43210GB
Swing reduction gear, disassembly and assembly .....	6004	9-43220GB
Travel reduction gear assembly and disassembly .....	6005	9-43150GB
<b>7 UNDERCARRIAGE HYDRAULICS</b>		
<b>8 UPPERSTRUCTURE HYDRAULICS</b>		
Depressurising and decontaminating the hydraulic system, use of the vacuum pump and bleeding the components .....	8000	9-43500GB
Specifications, troubleshooting, checks and hydraulic pressure settings .....	8001	9-36260GB
Hydraulic reservoir removal and installation .....	8002	9-43230GB
Main and pilot pumps, removal and installation .....	8003	9-43530GB
Main hydraulic control valve, removal and installation.....	8004	9-43260GB
Attachment cylinders, removal and installation .....	8005	9-43250GB
Hydraulic swivel, removal and installation .....	8006	9-43390GB
Pilot blocs, removal and installation.....	8007	9-43400GB
Swing motor, removal and installation .....	8008	9-43200GB
Main hydraulic pump, disassembly and assembly .....	8010	9-43240GB
.....	8010	9-43330GB
Main hydraulic control valve, disassembly and assembly.....	8011	9-43550GB
Attachment cylinders, disassembly and assembly.....	8012	9-43320GB
Hand control levers, disassembly and assembly .....	8013	9-43340GB
Foot control levers, disassembly and assembly .....	8014	7-28300GB
Six-solenoid valves, disassembly and assembly .....	8015	9-43360GB
Caution valve, disassembly and assembly .....	8016	7-27942GB
Safety valve .....	8017	9-43380GB
Hydraulic swivel, disassembly and assembly .....	8018	9-43190GB
Swing motor, disassembly and assembly .....	8019	9-43440GB
Hydraulic functions.....	8020	9-42740GB
Travel hydraulic motor, disassembly and assembly.....	8021	9-43160GB

DIVISION/SECTION	SECTION N°	REFERENCE N°
<b>9 UPPERSTRUCTURE</b>		
Upperstructure, turntable and counterweight.....	9002	9-43410GB
Boom, dipper and bucket.....	9003	9-43420GB
Seat and seat belt.....	9004	9-40460GB
Cab and cab equipment.....	9005	9-43430GB
Air conditioning troubleshooting.....	9006	██████████
Air conditioning unit disassembly and assembly.....	9007	██████████
Air conditioning servicing.....	9008	██████████
Air conditioning components.....	9009	██████████
Large format hydraulic and electrical schematics.....	Pocket	<b>9-35930GB</b>

\* *Consult the Engine Service Manual*

██████████ *Sections to be distributed at a later date*

NOTE: CASE Company reserves the right to make changes in the specification and design of the machine without prior notice and without incurring any obligation to modify units previously sold.

The description of the models shown in this manual has been made in accordance with the technical specifications known as of the date of design of this document.

# Section

# 1001

**SAFETY, GENERAL INFORMATION  
AND STANDARD TORQUE DATA**

**<https://www.ebooklibonline.com>**

Hello dear friend!

Thank you very much for reading.

Enter the link into your browser.

The full manual is available for immediate download.

**<https://www.ebooklibonline.com>**

## GENERAL INFORMATION

### Cleaning

Clean all metal parts except bearings, in a suitable cleaning solvent or by steam cleaning. Do not use caustic soda for steam cleaning. After cleaning, dry and put oil on all parts. Clean oil passages with compressed air. Clean bearings in a suitable cleaning solvent. Dry the bearings completely and put oil on the bearings.

### Inspection

Check all parts when the parts are disassembled. Replace all parts that have wear or damage. Small scoring or grooves can be removed with a hone or crocus cloth. Complete a visual inspection for indications of wear, pitting and the replacement of parts necessary to prevent early failures.

### Bearings

Check bearings for easy action. If bearings have a loose fit or rough action, replace the bearing. Wash bearings with a suitable cleaning solvent and permit to air dry. DO NOT DRY BEARINGS WITH COMPRESSED AIR.

### Needle Bearings

Before you press needle bearings in a bore always remove any metal protrusions in the bore or edge of the bore. Before you press bearings into position, put petroleum jelly on the inside and outside diameter of the bearings.

### Gears

Check all gears for wear and damage. Replace gears that have wear or damage.

### Oil Seals, O-rings and Gaskets

Always install new oil seals, O-rings and gaskets. Put petroleum jelly on seals and O-rings.

### Shafts

Check all shafts that have wear or damage. Check the bearing and oil seal surfaces of the shafts for damage.

### Service Parts

Always install genuine Case service parts. When ordering refer to the Parts Catalog for the correct part number of the genuine Case replacement items. Failures due to the use of other than genuine Case replacement parts are not covered by warranty.

### Lubrication

Only use the oils and lubricants specified in the Operator's or Service Manuals. Failures due to the use of non-specified oils and lubricants are not covered by warranty.

## SAFETY



*This symbol means ATTENTION! BECOME ALERT! YOUR SAFETY IS INVOLVED. The message that follows the symbol contains important information about safety. Carefully read the message. Make sure you fully understand the causes of possible injury or death.*

To prevent injury always follow the Warning, Caution and Danger notes in this section and throughout the manual.

Place a "Do not operate" tag on the starter switch key before carrying out any service or repair work on the machine.



**WARNING:** *Read the operator's manual to familiarize yourself with the correct control functions.*



**WARNING:** *Operate the machine and equipment controls from the seat position only. Any other method could result in serious injury.*



**WARNING:** *This is a one man machine, no riders allowed.*



**WARNING:** *Before starting engine, study Operator's Manual safety messages. Read all safety signs on machine. Clear the area of other persons. Learn and practice safe use of controls before operating.*

*It is your responsibility to understand and follow manufacturers instructions on machine operation, service and to observe pertinent laws and regulations. Operator's and Service Manuals may be obtained from your Case dealer.*



**WARNING:** *If you wear clothing that is too loose or do not use the correct safety equipment for your job, you can be injured. Always wear clothing that will not catch on objects. Extra safety equipment that can be required includes hard hat, safety shoes, ear protection, eye or face protection, heavy gloves and reflector clothing.*



**WARNING:** *When working in the area of the fan belt with the engine running, avoid loose clothing if possible, and use extreme caution.*



**WARNING:** *When doing checks and tests on the equipment hydraulics, follow the procedures as they are written. DO NOT change the procedure.*



**WARNING:** *When putting the hydraulic cylinders on this machine through the necessary cycles to check operation or to remove air from a circuit, make sure all people are out of the way.*



**WARNING:** Use insulated gloves or mittens when working with hot parts.



**WARNING:** Lower all attachments to the ground or use stands to safely support the attachments before you do any maintenance or service.



**WARNING:** Pin sized and smaller streams of hydraulic oil under pressure can penetrate the skin and result in serious infection. If hydraulic oil under pressure does penetrate the skin, seek medical treatment immediately. Maintain all hoses and tubes in good condition. Make sure all connections are tight. Make a replacement of any tube or hose that is damaged or thought to be damaged. DO NOT use your hand to check for leaks, use a piece of cardboard or wood.



**WARNING:** When removing hardened pins such as a pivot pin, or a hardened shaft, use a soft head (brass or bronze) hammer or use a driver made from brass or bronze and a steel head hammer.



**WARNING:** When using a hammer to remove and install pivot pins or separate parts using compressed air or using a grinder, wear eye protection that completely encloses the eyes (approved goggles or other approved eye protectors).



**WARNING:** Use suitable floor (service) jacks or chain hoist to raise wheels or tracks off the floor. Always block machine in place with suitable safety stands.



**WARNING:** When servicing or repairing the machine, keep the shop floor and operator's compartment and steps free of oil, water, grease, tools, etc. Use an oil absorbing material and/or shop cloths as required. Use safe practices at all times.



**WARNING:** Some components of this machine are very heavy. Use suitable lifting equipment or additional help as instructed in this Service Manual.



**WARNING:** Engine exhaust fumes can cause death. If it is necessary to start the engine in a closed place, remove the exhaust fumes from the area with an exhaust pipe extension. Open the doors and get outside air into the area.



**WARNING:** When the battery electrolyte is frozen, the battery can explode if (1), you try to charge the battery, or (2), you try to jump start and run the engine. To prevent the battery electrolyte from freezing, try to keep the battery at full charge. If you do not follow these instructions, you or others in the area can be injured.

# Section

# 2000

## REMOVAL AND INSTALLATION OF THE ENGINE

## ENGINE

### Removal and installation

#### STEP 1

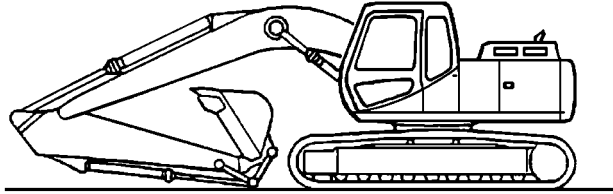

JS00163A

Park the machine on hard, flat ground. Lower the attachment to the ground.

#### STEP 2

Release pressure in the hydraulic system and in the hydraulic reservoir (see Section 8000).

#### STEP 3

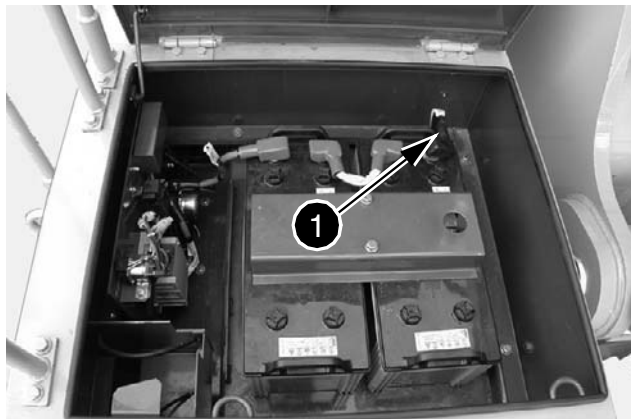

CD01C162

Disconnect the battery ground (-) cable (1) from the battery.

#### STEP 4

Refer to Section 8003 and remove the hydraulic pump.

#### STEP 5

Refer to Section 2001 and remove the radiator and oil-cooler assembly.

#### STEP 6

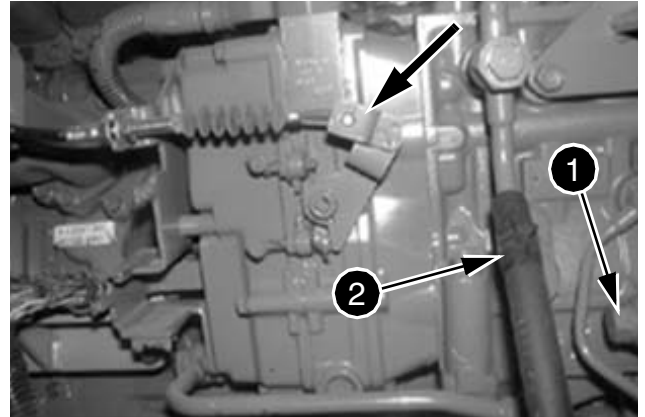

CD02C151

Remove the engine shutdown control (arrow).

Disconnect the fuel supply pipe (1) and the fuel return pipe (2) and plug them.

#### STEP 7

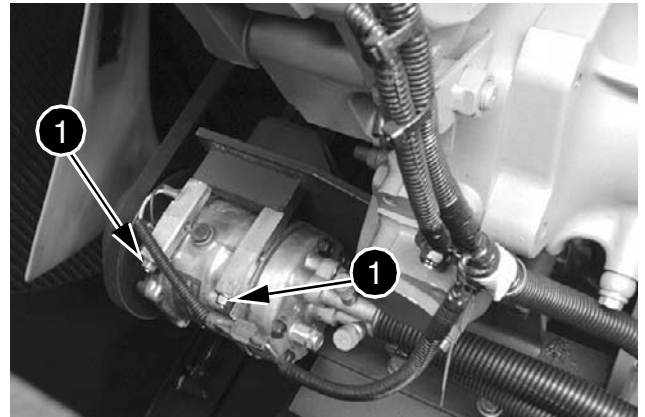

CD01D131

Remove the screws (1) from the compressor and put it away from the engine.

**STEP 8**

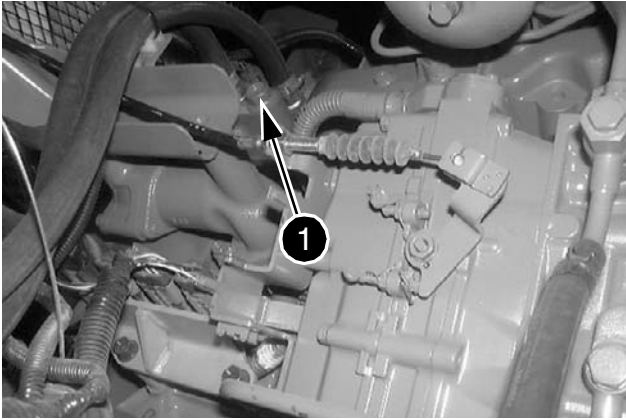

CD02C152

Label and disconnect the electrical connections from the water temperature sensor (1).

**STEP 9**

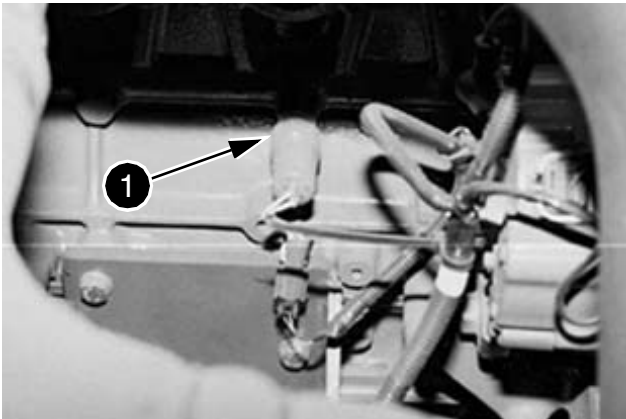

CD02C153

Label and disconnect the electrical connections from the oil pressure sensor (1).

**STEP 10**

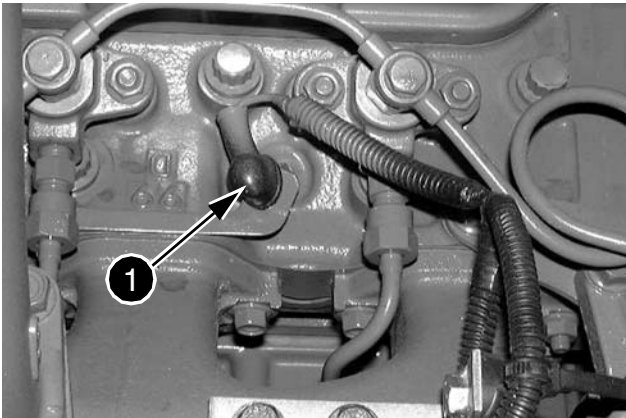

CD00J030

Label and disconnect the electrical supply (1) to the pre-heating plugs.

**STEP 11**

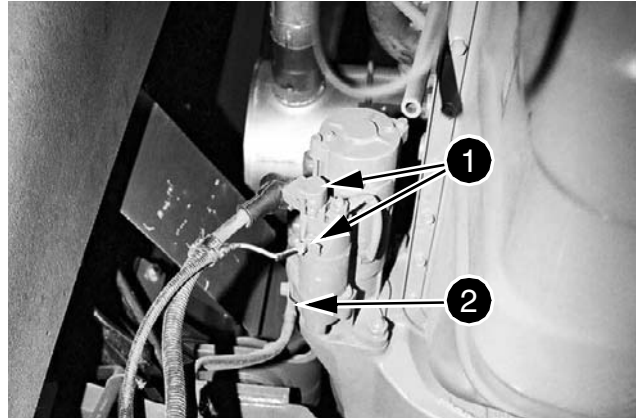

CD02C154

Label and disconnect the electrical connections to the starter motor (1). Remove the earth cable (2) at the engine end.

**STEP 12**

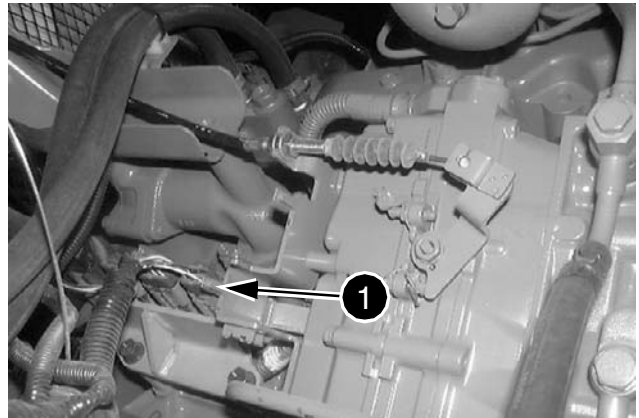

CD02C152

Label and disconnect the electrical connections of the electronic regulation (1) from the engine.

**STEP 13**

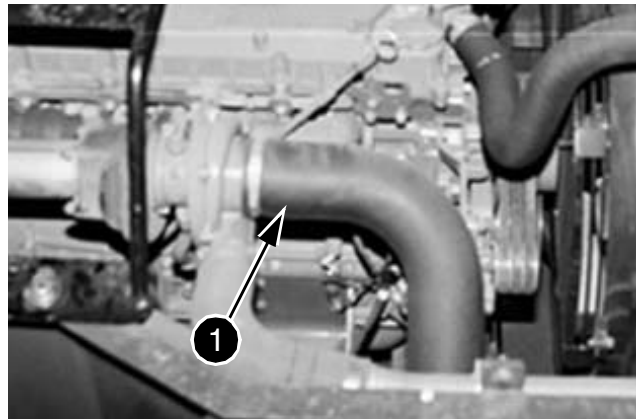

CD02C155

Remove the hose connecting the turbo-charger to the air filter (1).

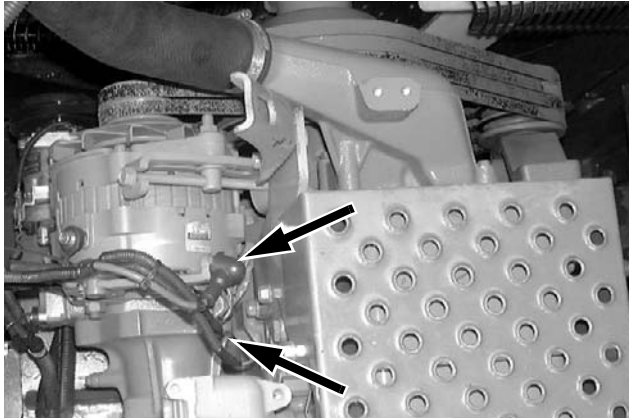
**STEP 14**

Label and disconnect the electrical connections to the alternator (arrows).

**STEP 15**

Remove all the clips, etc, which fasten the electrical harnesses to the engine and move the harnesses out of the way.

**STEP 16**

Install a suitable lifting device on the engine lifting rings (for the weight of the engine, see Section 1002).

**STEP 17**

Remove the engine retaining hardware.

**NOTE:** *When installing, make a visual inspection of the condition of the rubber flexible mountings and change them if necessary. Respect the colours, light blue on the fan side, light green on the hand-wheel side. Tighten the engine retaining screws to a torque of  $313 \pm 25$  Nm.*

**STEP 18**

When there is nothing interfering with the removal of the engine, raise the engine carefully and install it on a suitable repair bench.

**NOTE:** *When installing the engine in the machine, proceed in the reverse order from removal.*

Before operating the machine, carry out the following operations:

- Bleed and prime the fuel system (see Operator's Manual).
- Fill and bleed the engine cooling system (see Operator's Manual).
- Check the hydraulic, fuel and cooling systems for leaks.
- Check the oil level in the hydraulic reservoir. Top up if necessary.

# CHANGING THE RADIATOR OR THE OIL-COOLER

## Description

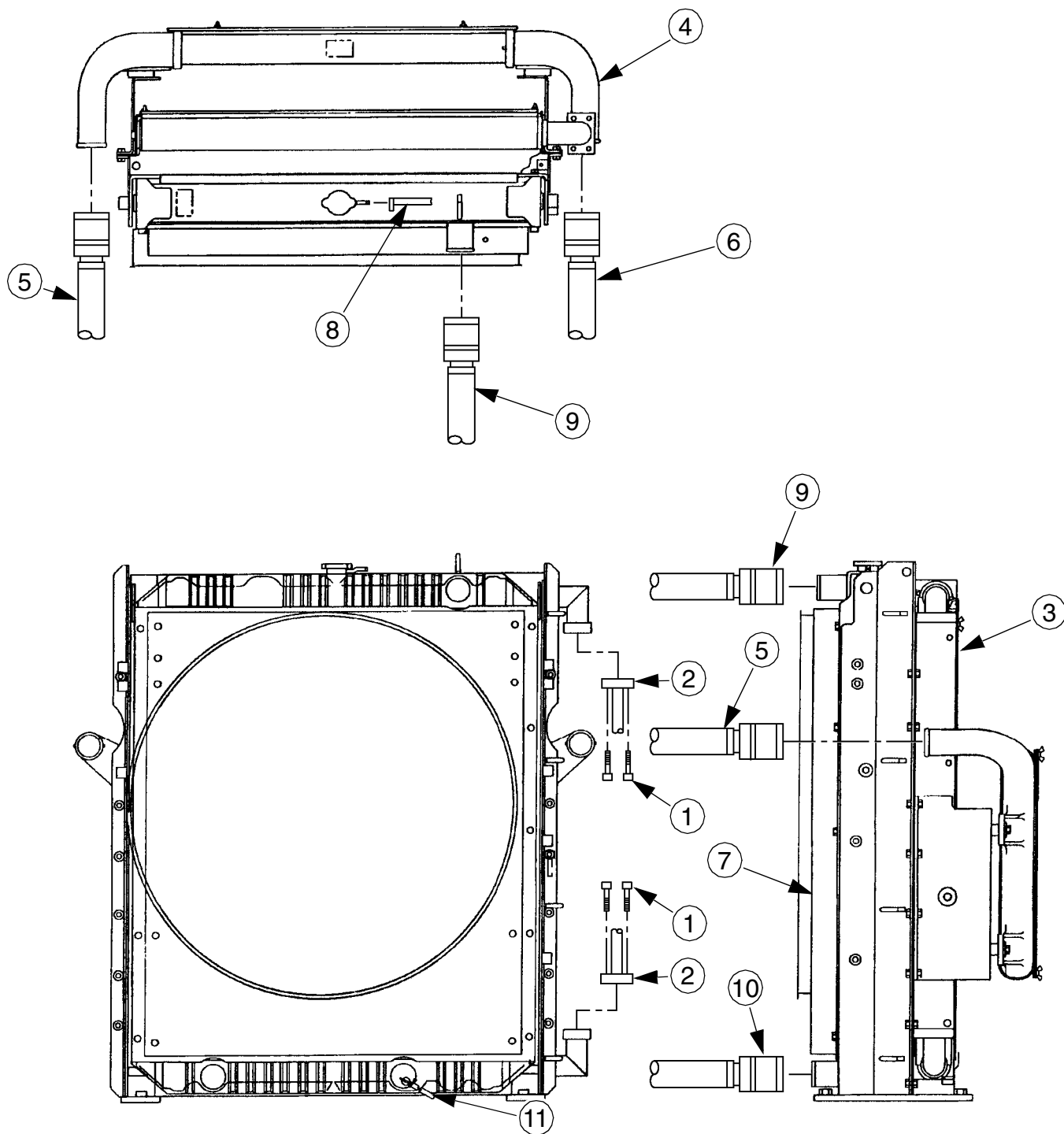

- 1 SCREW
- 2 PIPE
- 3 OIL COOLER
- 4 OIL-COOLER
- 5 HOSE
- 6 HOSE

- 7 RADIATOR
- 8 HOSE
- 9 HOSE
- 10 HOSE
- 11 HOSE

CI02A513

## RADIATOR AND OIL-COOLER

Before carrying out any operation on the machine, perform the following operations in the order shown:

- Park the machine on hard, flat ground.
- Lower the attachment to the ground.
- Shut down the engine.
- Remove the starter switch key.
- Make sure that pressure in the hydraulic system has been completely released (see Operator's Manual).



**WARNING:** When the machine is working, the engine components and the hydraulic pump reach a high temperature. To avoid being burnt by hot metal or scalded by high temperature water or oil, allow the machine to cool down before starting any servicing operation.

### Removal of the radiator and oil-cooler assembly

#### STEP 1

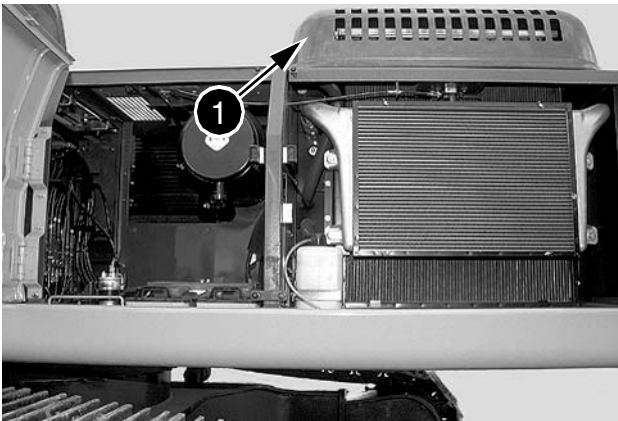

CD01K055

Remove the hood (1) from the engine.

#### STEP 2

Remove the inner cover plate from the engine.

#### STEP 3

Remove the cap from the expansion reservoir.

**IMPORTANT:** Do not remove the cap when the engine is hot, since the system would still be under pressure and you could be scalded.

#### STEP 4

Drain the cooling system (see Operator's Manual).

#### STEP 5

Release pressure in the hydraulic reservoir to allow the vacuum pump to be mounted (see Section 8000).

**NOTE:** The numbers within brackets refer to the figure on page 3.

#### STEP 6

Remove the screws (1), then the pipe (2) from the oil cooler (3), finally drain the latter into a clean container.

#### STEP 7

Disconnect the radiator hoses (5) and (6) from the oil-cooler, finally drain the latter into a clean container.

#### STEP 8

Remove the expansion reservoir hose (8) from the radiator (7). Disconnect the return hose (9) and the water pump suction hose (10) from the engine.

#### STEP 9

Disconnect the radiator hose (11) from the oil drain plug.

#### STEP 10

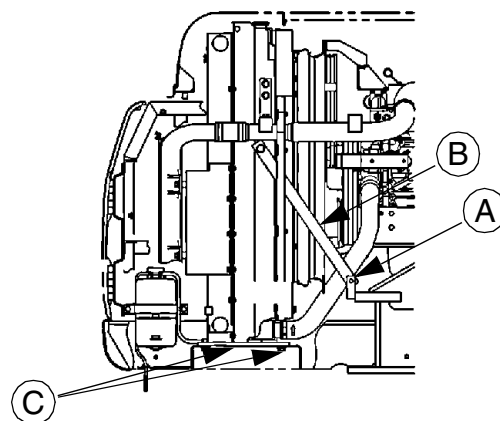

CS02C554

Remove the screws (A) and remove the guardrails (B). Remove the screws (C).



**Suggest:**

**If the above button click is invalid.**

**Please download this document**

**first, and then click the above link**

**to download the complete manual.**

**Thank you so much for reading**

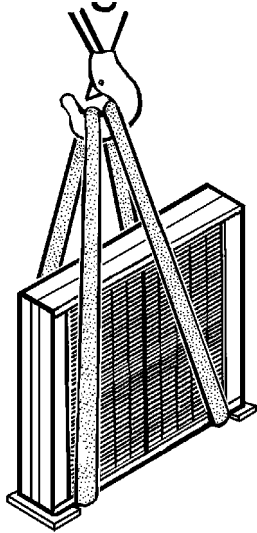
**STEP 11**

CS00G513

Pass a suitable sling right around the radiator and oil-cooler assembly and, using a suitable lifting device, remove the radiator and oil-cooler assembly.

**NOTE:** *During the lifting operation, unlock the radiator and oil-cooler assembly in order to free the engine cooling fan.*

**Installation**

When installing, proceed in the reverse order from that of removal.

Before operating the machine:

- Check the oil level in the hydraulic reservoir. Top up if necessary.
- Check the hydraulic fluid cooling circuit for leaks.
- Fill and bleed the engine cooling system (see Operator's Manual).
- Check the engine cooling system for leaks.

## FUEL TANK

### Removal

#### STEP 1

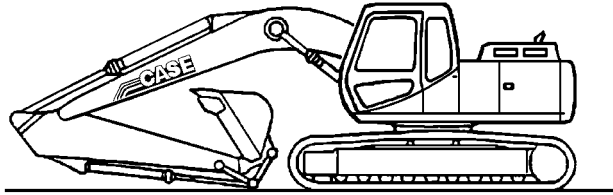

JS00163A

Park the machine on hard, flat ground. Lower the attachment to the ground.

#### STEP 2

Reduce the engine speed to idle for 30 seconds, then shut down the engine.

#### STEP 3

Turn the ignition key to "ON" without starting the engine.

#### STEP 4

Attach a "DO NOT OPERATE" tag to the ignition key in the cab.

#### STEP 5

**NOTE:** *The numbers within brackets refer to the figures on pages 5 and 6.*

Remove the access panel under the fuel reservoir (1).

#### STEP 6

Open the filling plug (2) of the tank (1). Bleed the remaining fuel using the valve (3) then remove the latter. Remove the filter (19) and the fuel gauge (20).

#### STEP 7

Lift the hood of the front boot. Remove the retaining screw (4) of the access ramp (5). Remove the access ramp (5).

#### STEP 8

Remove the screws (6) on top and then inside the front boot, then remove the protective housing (7).

#### STEP 9

Remove the screws (8) and the protective plate (9) from on top of the fuel reservoir (1).

#### STEP 10

Loosen the two screws (10) located under the machine. Open the side portion of the machine and remove the two screws (11) located on the RH side of the fuel reservoir (1). Remove the protective plate of the reservoir (12).

#### STEP 11

Remove the two screws that hold the fuel oil filter. Attach labels on the two hoses. Remove the fuel oil filter by removing the two hoses and the retaining clips.

#### STEP 12

Shift the plastic protection (13) from the fuel sensor (14). Remove the retaining screws (15) then the fuel sensor (14) as well as the seal (16).

#### STEP 13

Remove the six screws (17) from the fuel tank (1), and the shims (18).

#### STEP 14

Remove the fuel tank (1) using a hoist.

#### STEP 15

See the operator's manual for removing the fuel filter.

**<https://www.ebooklibonline.com>**

Hello dear friend!

Thank you very much for reading.

Enter the link into your browser.

The full manual is available for immediate download.

**<https://www.ebooklibonline.com>**