

1. Trim along dashed line.
2. Slide into pocket on Binder Spine.

TYPE 1-4

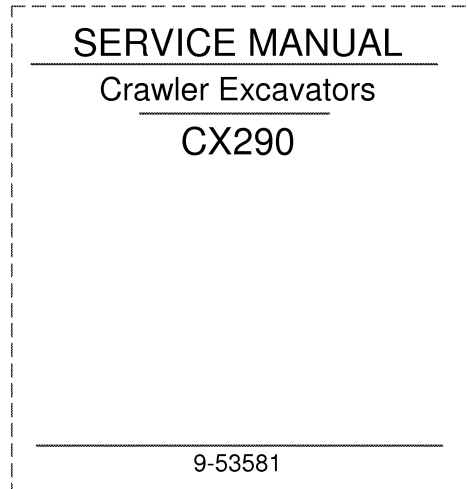

1. Trim along dashed line.
2. Slide into pocket on Binder Spine.

TYPE 1-4

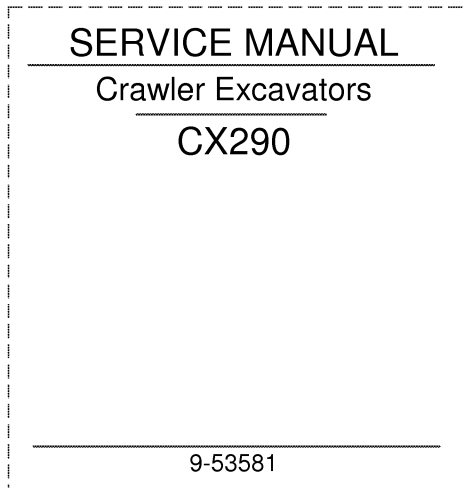

1. Trim along dashed line.
2. Slide into pocket on Binder Spine.

TYPE 1-4

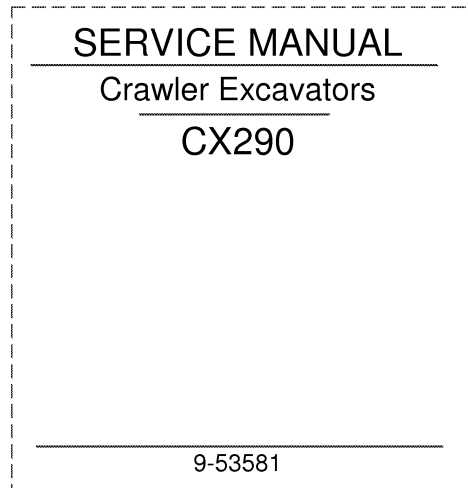

1. Trim along dashed line.
2. Slide into pocket on Binder Spine.

TYPE 1-4

CX290 Crawler Excavators

Table of contents

DIVISION/SECTION	SECTION No.	REFERENCE No.
1 GENERAL INFORMATION		
Safety, general information and standard torque data	1001	9-53360
General specifications and special torque setting.....	1002	9-53220
2 ENGINE		
Removal and installation of the engine	2000	9-43820GB
Radiator and oil-cooler	2001	9-44490GB
Engine specifications	*	
Disassembly and assembly of the engine.....	*	
3 FUEL SYSTEM		
Fuel tank	3001	7-27970GB
Fuel engine system.....	*	
4 ELECTRICAL SYSTEM		
Electrical system, electrical and electronic troubleshooting	4001	9-53380
Inspection and maintenance of batteries and connecting a booster battery....	4002	9-43460GB
Main and engine electronic control boxes	4003	9-43450GB
5 UNDERCARRIAGE		
Removal and installation of tracks	5001	7-27750GB
Rollers	5003	9-42920GB
Sprocket	5004	9-36890GB
Idler wheel and tension shock absorber	5005	9-43000GB
6 DRIVE TRAIN		
Drive motor and final drive transmission removal and installation	6001	9-43140GB
Swing reduction gear, removal and installation	6003	9-44010GB
Swing reduction gear, disassembly and assembly.....	6004	9-43220GB
Travel reduction gear assembly and disassembly.....	6005	9-43150GB
7 UNDERCARRIAGE HYDRAULICS		
8 UPPERSTRUCTURE HYDRAULICS		
Depressurising and decontaminating the hydraulic system, use of the vacuum pump and bleeding the components	8000	9-44030GB
Specifications, troubleshooting, checks and hydraulic pressure settings.....	8001	9-53390
Hydraulic reservoir removal and installation	8002	7-27990GB
Main and pilot pumps, removal and installation	8003	9-44050GB
Main hydraulic control valve, removal and installation	8004	9-44410GB
Attachment cylinders, removal and installation	8005	7-27791GB
Hydraulic swivel, removal and installation.....	8006	7-27811GB
Pilot blocs, removal and installation	8007	9-35590
Swing motor, removal and installation.....	8008	9-44020GB
Free swing disassembly and assembly	8009	9-35530
Main hydraulic pump, disassembly and assembly	8010	9-35491GB
Main hydraulic control valve, disassembly and assembly	8011	9-43550GB
Attachment cylinders, disassembly and assembly.....	8012	9-44420GB
Hand control levers, disassembly and assembly	8013	7-28110GB
Foot control levers, disassembly and assembly	8014	7-28210GB
Six-solenoid valves, disassembly and assembly.....	8015	9-43360GB
Caution valve, disassembly and assembly.....	8016	7-27942GB
Safety valve.....	8017	7-29631GB
Hydraulic swivel, disassembly and assembly.....	8018	7-28080GB
Swing motor, disassembly and assembly	8019	9-43440GB
Hydraulic functions.....	8020	9-53400
Travel hydraulic motor, disassembly and assembly.....	8021	9-43160GB

DIVISION/SECTION	SECTION No.	REFERENCE No.
9 UPPERSTRUCTURE		
Upperstructure, turntable and counterweight.....	9002	9-43760GB
Boom, dipper and bucket	9003	7-27961GB
Seat and seat belt	9004	9-40960GB
Cab and cab equipment.....	9005	9-43750GB
Air conditioner troubleshooting and system checks	9006	9-88730GB
Air conditioning unit disassembly and assembly	9007	██████████
Air conditioning servicing	9008	██████████
Air conditioning components.....	9009	██████████
Attachment reinforcement procedures	9012	9-43910
Large format hydraulic and electrical schematics	Pocket	9-42670

* Consult the Engine Service Manual

██████████ Sections to be distributed at a later date

NOTE: Case Company reserves the right to make changes in the specification and design of the machine without prior notice and without incurring any obligation to modify units previously sold.

The description of the models shown in this manual has been made in accordance with the technical specifications known as of the date of design of this document.

<https://www.ebooklibonline.com>

Hello dear friend!

Thank you very much for reading.

Enter the link into your browser.

The full manual is available for immediate download.

<https://www.ebooklibonline.com>

REVISION No. 1
Crawler excavators
CX290
Service manual Cre 9-53580

Revision contents:

9-53581	Identification Decal	New Decal
9-53431	Table of Contents.....	New Table of Contents
9-88870GB	Section 9006 - Air Conditioner Troubleshooting and System Checks.....	New Section

NOTE: *Keep this revision page with the first pages in your binder for reference purposes. If you have several revisions to insert at the same time, start with the oldest, then the next oldest, and so on.*

Section 1001

SAFETY, GENERAL INFORMATION

TABLE OF CONTENTS

GENERAL INFORMATION	3
SAFETY	4
STANDARD TORQUE DATA FOR CAP SCREWS AND NUTS.....	6

GENERAL INFORMATION

Cleaning

Clean all metal parts except bearings, in a suitable cleaning solvent or by steam cleaning. Do not use caustic soda for steam cleaning. After cleaning, dry and put oil on all parts. Clean oil passages with compressed air. Clean bearings in a suitable cleaning solvent. Dry the bearings completely and put oil on the bearings.

Inspection

Check all parts when the parts are disassembled. Replace all parts that have wear or damage. Small scoring or grooves can be removed with a hone or crocus cloth. Complete a visual inspection for indications of wear, pitting and the replacement of parts necessary to prevent early failures.

Bearings

Check bearings for easy action. If bearings have a loose fit or rough action, replace the bearing. Wash bearings with a suitable cleaning solvent and permit to air dry. DO NOT DRY BEARINGS WITH COMPRESSED AIR.

Needle Bearings

Before you press needle bearings in a bore always remove any metal protrusions in the bore or edge of the bore. Before you press bearings into position, put petroleum jelly on the inside and outside diameter of the bearings.

Gears

Check all gears for wear and damage. Replace gears that have wear or damage.

Oil Seals, O-rings and Gaskets

Always install new oil seals, O-rings and gaskets. Put petroleum jelly on seals and O-rings.

Shafts

Check all shafts that have wear or damage. Check the bearing and oil seal surfaces of the shafts for damage.

Service Parts

Always install genuine Case service parts. When ordering refer to the Parts Catalog for the correct part number of the genuine Case replacement items. Failures due to the use of other than genuine Case replacement parts are not covered by warranty.

Lubrication

Only use the oils and lubricants specified in the Operator's or Service Manuals. Failures due to the use of non-specified oils and lubricants are not covered by warranty.

SAFETY



This symbol means ATTENTION! BECOME ALERT! YOUR SAFETY IS INVOLVED. The message that follows the symbol contains important information about safety. Carefully read the message. Make sure you fully understand the causes of possible injury or death.

To prevent injury always follow the Warning, Caution and Danger notes in this section and throughout the manual.

Place a "Do not operate" tag on the starter switch key before carrying out any service or repair work on the machine.



WARNING: *Read the operator's manual to familiarize yourself with the correct control functions.*



WARNING: *Operate the machine and equipment controls from the seat position only. Any other method could result in serious injury.*



WARNING: *This is a one man machine, no riders allowed.*



WARNING: *Before starting engine, study Operator's Manual safety messages. Read all safety signs on machine. Clear the area of other persons. Learn and practice safe use of controls before operating.*

It is your responsibility to understand and follow manufacturers instructions on machine operation, service and to observe pertinent laws and regulations. Operator's and Service Manuals may be obtained from your Case dealer.



WARNING: *If you wear clothing that is too loose or do not use the correct safety equipment for your job, you can be injured. Always wear clothing that will not catch on objects. Extra safety equipment that can be required includes hard hat, safety shoes, ear protection, eye or face protection, heavy gloves and reflector clothing.*



WARNING: *When working in the area of the fan belt with the engine running, avoid loose clothing if possible, and use extreme caution.*



WARNING: *When doing checks and tests on the equipment hydraulics, follow the procedures as they are written. DO NOT change the procedure.*



WARNING: *When putting the hydraulic cylinders on this machine through the necessary cycles to check operation or to remove air from a circuit, make sure all people are out of the way.*



WARNING: Use insulated gloves or mittens when working with hot parts.



WARNING: Lower all attachments to the ground or use stands to safely support the attachments before you do any maintenance or service.



WARNING: Pin sized and smaller streams of hydraulic oil under pressure can penetrate the skin and result in serious infection. If hydraulic oil under pressure does penetrate the skin, seek medical treatment immediately. Maintain all hoses and tubes in good condition. Make sure all connections are tight. Make a replacement of any tube or hose that is damaged or thought to be damaged. DO NOT use your hand to check for leaks, use a piece of cardboard or wood.



WARNING: When removing hardened pins such as a pivot pin, or a hardened shaft, use a soft head (brass or bronze) hammer or use a driver made from brass or bronze and a steel head hammer.



WARNING: When using a hammer to remove and install pivot pins or separate parts using compressed air or using a grinder, wear eye protection that completely encloses the eyes (approved goggles or other approved eye protectors).



WARNING: Use suitable floor (service) jacks or chain hoist to raise wheels or tracks off the floor. Always block machine in place with suitable safety stands.



WARNING: When servicing or repairing the machine, keep the shop floor and operator's compartment and steps free of oil, water, grease, tools, etc. Use an oil absorbing material and/or shop cloths as required. Use safe practices at all times.



WARNING: Some components of this machine are very heavy. Use suitable lifting equipment or additional help as instructed in this Service Manual.



WARNING: Engine exhaust fumes can cause death. If it is necessary to start the engine in a closed place, remove the exhaust fumes from the area with an exhaust pipe extension. Open the doors and get outside air into the area.



WARNING: When the battery electrolyte is frozen, the battery can explode if (1), you try to charge the battery, or (2), you try to jump start and run the engine. To prevent the battery electrolyte from freezing, try to keep the battery at full charge. If you do not follow these instructions, you or others in the area can be injured.

STANDARD TORQUE DATA FOR CAP SCREWS AND NUTS

Tightening of Cap Screws and Nuts

Tighten alternately so that tightening torque can be applied evenly. The numbers in the figure below indicate the order of tightening.

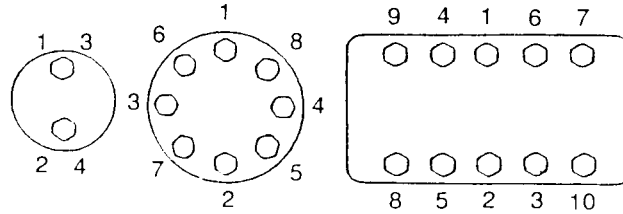

JS00481B

Cap screws which have had Loctite used (white residue remains after removal) should be cleaned with light oil or suitable cleaning solvent and dried. Apply 2-3 drops of Loctite to the thread portion of the cap screw and then tighten.

Torque Table

Tighten cap screws and nuts according to the table below if there are no other special instructions.

Cap Screw Name Size			M6	M8	M10	M12	M14	M16	M18	M20
Cap Screw	Wrench size	[in.]	0.39	0.51	0.67	0.75	0.87	0.95	1.06	1.18
		[mm]	10	13	17	19	22	24	27	30
	Tightening torque	[lb-ft]	5.1	14.5	29.0	43.4	72.5	116.0	144.6	202.4
		[Nm]	6.9	19.6	39.2	58.8	98.1	157.2	196.0	274.0
Socket Head Cap Screw	Wrench size	[in.]	0.20	0.24	0.32	0.39	0.47	0.55	0.55	0.67
		[mm]	5	6	8	10	12	14	14	17
	Tightening torque	[lb-ft]	6.5	15.9	31.1	57.8	86.8	130.1	180.8	253.1
		[Nm]	8.8	21.6	42.1	78.4	117.6	176.4	245.0	343.0

Section 1002

1002

SPECIFICATIONS AND SPECIAL TORQUE SETTINGS

TABLE OF CONTENTS

TYPE, SERIAL NUMBER AND YEAR OF MANUFACTURE OF THE MACHINE	3
Machine.....	3
Engine	3
Serial numbers of the components	3
INGREDIENTS	4
Hydraulic fluid chart.....	4
Transmission assembly oil	4
Greases	4
Engine oil	5
Viscosity of oils/Operating range of oils	5
Fuel	6
Antifreeze/anticorrosive	6
Environment	6
Plastic and resin parts	6
SPECIFICATIONS.....	7
Engine	7
Capacities	7
Electrical system	7
Hydraulic system	8
Cylinder	8
Control valve	9
Swing	9
Travel	9
Undercarriage	9
Attachment.....	9
Weight of components	10
DIMENSIONS AND WEAR LIMIT OF THE TRACK ASSEMBLY	11
Sprocket	11
Idler wheel.....	12
Upper roller	13
Lower roller	14
Track	15
DIMENSIONS AND WEAR LIMITS OF ATTACHMENT LINKAGES	16
Boom foot/Frame	16
Boom cylinder foot/Frame	17
Boom cylinder head/Boom	17
Dipper cylinder foot/Boom.....	18
Boom/Dipper	18
Dipper cylinder head/Dipper.....	18
Bucket cylinder foot/Dipper	19
Connecting rod/Dipper	19
Compensator/Bucket.....	19
Connecting rod/Compensator/Bucket cylinder head.....	20
Dipper/Bucket.....	20
SPECIAL TORQUE SETTINGS	21
MACHINE OVERALL DIMENSIONS.....	24



WARNING: *This symbol is used in this manual to indicate important safety messages. Whenever you see this symbol, carefully read the message which follows. Your safety depends on it.*

TYPE, SERIAL NUMBER AND YEAR OF MANUFACTURE OF THE MACHINE

For all part orders, request for information or assistance, always specify the type and the serial number of the machine to your Case dealer.

Fill in the following lines with the required information: Type, serial number, year of manufacture of the machine and the serial numbers of the hydraulic and mechanical components.

Machine

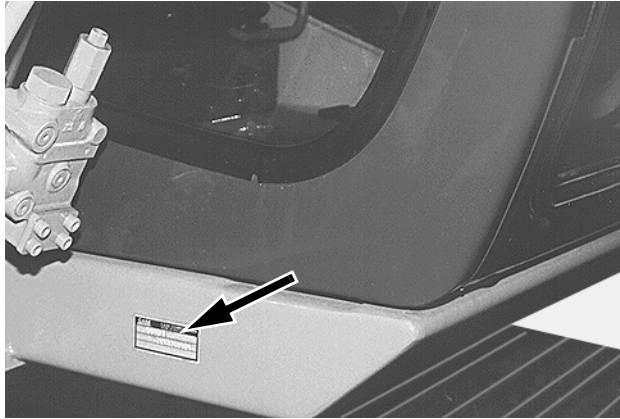

CP98N006

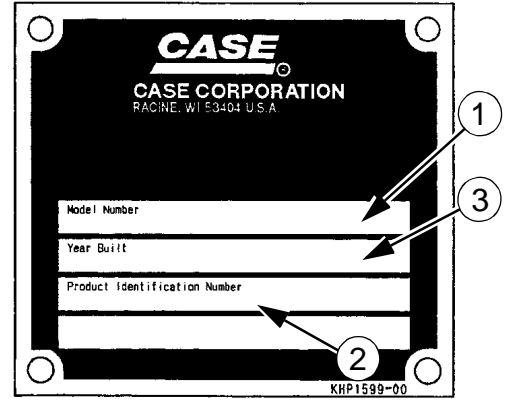

CS00M518

- (1) Type
- (2) Serial number
- (3) Year of manufacture

Engine

Make and type

Serial number

Serial numbers of the components

Hydraulic pump

Swing reduction gear

Travel reduction gears

Travel control valve

Attachment control valve

Swing control valve

INGREDIENTS

The ingredients must correspond to specific characteristics for every usage.



WARNING: You must respect the operating conditions for the different ingredients.

Hydraulic fluid chart

NOTE: Use only hydraulic oils meeting Case specifications or equivalent AW (anti-wear) hydraulic oils.

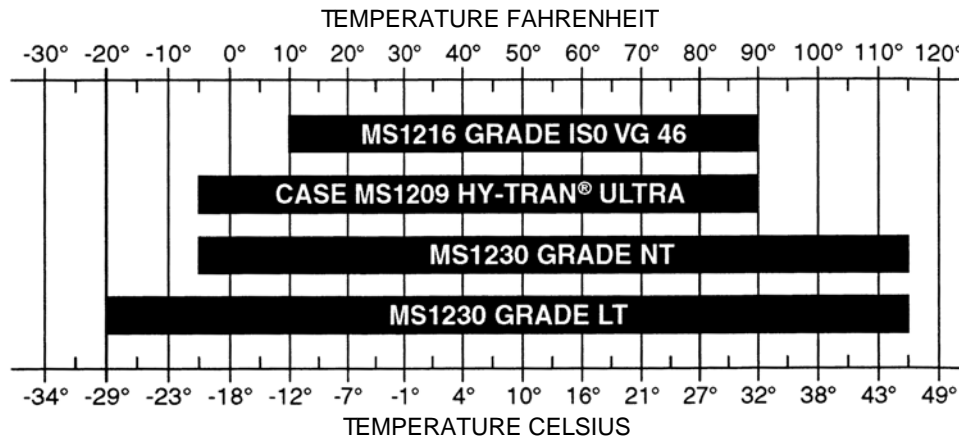

CS02K507

NOTE: Case specification MS1209 Fluid is used in place of ISO VG 32 (-5° to + 65° F) and ISO VG 46 (+10° to + 90° F).

NOTE: Case specifications MS1230 Grade NT or Grade LT is used in place of ISO VG 32 (-5° to + 65°F), ISO VG 46 (+10° to + 90°F), ISO VG 100 (+30° to +115°F) and MS1210 TCH

Transmission assembly oil

Extreme pressure oil used for transmission assemblies in housing.

Extreme pressure oil TYPE API GL5 GRADE 80W90 and ISO VG 150

Greases

The type of grease to be used depends on the ambient temperature.

Hot and temperate climates

-4°F to + 140°F (-20°C to +60°C)

Extreme pressure EP NLGI grade 2 grease with molybdenum disulfide.

Cold climates

-40°F to +68°F (-40°C to +20°C)

Extreme pressure EP NLGI grade 0 grease.

Engine Oil

THE CASE No. 1 engine oil is recommended for your engine. This oil ensures proper lubrication of your engine for all operating conditions.

If you are unable to procure the CASE No. 1 Multiperformance or Performance engine oil, use the corresponding oil from the API/CG/CF category.

NOTE: Do not put any Performance Additives or any other additives in the engine housing. The oil changing intervals are indicated in this manual based on tests carried out on CASE lubricants.



RD97F136



RD97F100

Oil Viscosity / Oil Range

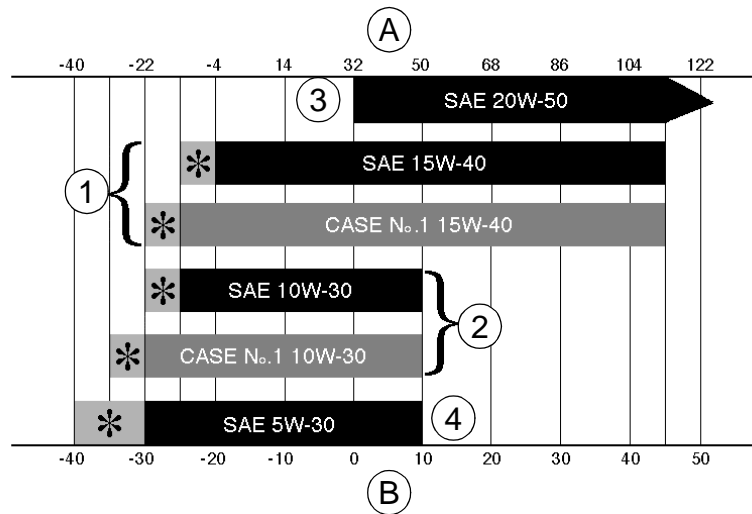

(A) FAHRENHEIT TEMPERATURE

(B) CELSIUS TEMPERATURE

(1) ALL-SEASONS

(2) WINTER

(3) TROPICAL

(4) ARCTIC

(*) SHOWS THAT AN ENGINE OIL HEATER OR ENGINE COOLANT SOLUTION HEATER MUST BE USED.

CS98M561

Fuel

The fuel to be used must comply with the D975 norm of the American Society for Testing and Materials (ASTM).

Use type No. 2 fuel, use of other fuels can cause a loss of engine power and excessive fuel consumption.

In cold weather, it is provisionally accepted that a mixture of No. 1 and No. 2 fuels be used. Contact your fuel supplier.

If the temperature drops below the freezing point of the fuel (point where paraffin appears), paraffin crystals in the fuel will cause loss of engine power or starting trouble.

IMPORTANT: *In cold weather, fill up the reservoir with fuel after each workday, in order to avoid the formation of condensation.*

Storing fuel

Prolonged storage of fuel promotes the accumulation of foreign bodies or condensed moisture in the storage tank. Many engine failures are caused by the presence of water in fuel.

The storage tank must be placed outside and the fuel should be maintained at as low a temperature as possible. Drain the condensed moisture at regular intervals.

Antifreeze/anticorrosive

Use the antifreeze in all seasons to protect the coolant system from corrosion and to avoid any risk of freezing.

In environments with a temperature greater than -33°F (-36°C), use a 50% mixture of antifreeze in an ethylene glycol base.

In environments with a temperature less than -33°F (-36°C), it is recommended that you use a 40% water and 60% antifreeze mixture.

Environment

Before carrying out any maintenance operation on this machine and before throwing away the liquids or lubricants used, always think of the environment. Never throw oil or liquids on the ground and never put them in leaking containers.

Consult your local centre for ecological recycling for information on the appropriate method for disposing off these substances.

Plastic and resin parts

When cleaning plastic parts, on the console, the instrument panel, the indicator and gauges etc., do not use gas, paraffin, paint solvents, etc. Use only water, soap and a soft cloth.

The use of gas, paraffin, paint solvents etc... causes discoloration, cracks or deformation of these parts.

SPECIFICATIONS

Engine

Make..... CDC
 Model..... 6TAA-590

Type: Four stroke, water cooled with overhead valves, direct injection in-line cylinder (electronic control) with turbocharger.

Number of cylinders..... 6
 Bore and stroke4.13 x 4.92 inches
 Displacement..... 359 cu in

Operating conditions

Idle..... 1000 rpm
 Max speed2250 rpm
 SAE net horse power..... 190 HP
 Max torque.....487 lb-ft at 1400 rpm

Capacities

Engine oil capacity..... 6.3 gallons
 Engine cooling circuit..... 7.6 gallons
 Capacity of only the radiator 5.2 gallons
 Fuel reservoir..... 89.8 gallons
 Hydraulic fluid reservoir capacity 31.7 gallons
 Total hydraulic circuit capacity 63.4 gallons
 Capacity of only the oil-cooler 4.1 gallons
 Travel reduction gear housing capacity 1.2 gallons
 Swing drive housing capacity 1.5 gallons
 Idler pulley capacity 8.25 oz
 Upper roller capacity..... 8.08 to 8.25 oz
 Lower roller capacity..... 9.24 oz

NOTE: *These capacities are given only for information purposes. To check the fluid levels, always use the oil gauge, visual gauges or the filler cap.*

Electrical system

Type of system24 volts earth negative
 Alternator amperage..... 50 amperes

Battery

Number of batteries required 2
 Voltage of each battery 12 volts
 Capacity 112 Ah
 Reserve..... 160 min
 Cold startability at 1.4°F 800 A
 Load for load control 400 A

Starter

Voltage 24 volts
 Power 4.5 kW

Voltage regulator built-in, without adjustment

Hydraulic system

Main hydraulic pump

Variable flow double pump, with axial pistons.

Maximum flow.....	2 x 58.4 gpm
Displacement.....	2 x 5.93 cu in

Hydraulic pilot pump

Fixed flow pump

Max flow	5.8 gpm
Displacement.....	0.61 cu in

Pressure setting

Pilot circuit relief	566 ± 14 psi
Main circuit relief (standard)	4975 ± 43 psi
Main circuit relief (power-up)	5410 ± 72 psi
Secondary relief (boom, dipper and bucket).....	5685 ± 72 psi
Secondary relief (swing).....	4264 ± 58 psi
Secondary relief (travel)	5511 ± 72 psi
Safety valve (boom and dipper).....	5685 ± 72 psi

Cylinder

Boom cylinder

Cylinder bore	5.31 in
Rod diameter	3.74 in
Stroke	53.89 in

Dipper cylinder

Cylinder bore	5.9 in
Rod diameter	4.13 in
Stroke	56.6 in

Bucket cylinder

Cylinder bore	5.11 in
Rod diameter	3.54 in
Stroke	42.2 in

Cylinder leakage - attachment lowering (without load)

Boom cylinders (rods retraction).....	0.11 in/5 min
Dipper cylinder (rod extension).....	0.19 in/5 min
Dipper cylinder (rod extension).....	0.27 in/5 min
Total (at the end of the attachment).....	7.87 in/5 min

Cylinder speed (in S mode)

Boom raised (bucket open and on the ground)	4.6 ± 0.6 seconds
Boom lowered (bucket open).....	3.7 ± 0.6 seconds
Dipper extended	2.9 ± 0.5 seconds
Dipper retracted.....	4.0 ± 0.5 seconds
Bucket open.....	2.5 ± 0.5 seconds
Bucket closed	4.9 ± 0.5 seconds

Control valve

Five-element control valve for dipper, boom acceleration, swing, option and right travel.

Four-element control valve for dipper acceleration, bucket, boom and left travel.

Anti-drift relief valve for boom and dipper.

Swing

Fixed flow engine with axial pistons.

Automatic disk brakes.

Upperstructure frame swing speed.....	10.4 rpm
Tail swing.....	10 ft 5 in
Displacement.....	10.05 cu in
Work flow.....	57.3 gpm
Reduction ratio.....	27.143
Brake torque.....	≥ 694 lb ft
Minimum brake release pressure.....	421 psi
Permissible motor leak.....	4.22 gpm

Travel

Two-speed motor with axial pistons.

Automatic disk brakes.

Low speed.....	1.8 mph
High speed.....	3.1 mph
Gradeability.....	70% (35°)
Tractive effort.....	54178 lbf
Displacement.....	14.9/8.6 cu in
Work flow.....	57.3 gpm
Reduction ratio.....	39.875
Braking torque (reduction gear excluded).....	≥ 665 lb ft
Number of sprocket turns (10 turns)	
Mode "S", low speed.....	30.0 ± 0.7 seconds
Mode "S", high speed.....	17.7 ± 0.6 seconds
Permissible deviation in travel over a distance of 65 ft 7 in	
Mode "H", full speed.....	39.36 in
Permissible motor leak.....	3.43 gpm

Undercarriage

Monobloc frame with fabricated elements.

Lubricated rollers and idler wheels.

Grease track tension.

Ground pressure

with 23.6 in track pads.....	7.83 psi
with 27.5 in track pads.....	6.96 psi
with 31.4 in track pads.....	6.09 psi

Track tension..... 13.38 to 14.17 in

Attachment

Digging force..... 38891 lbf

Break-out force

8 ft 8 in dipper.....	30798 lbf
10 ft 6 in dipper.....	28101 lbf
11 ft 2 in dipper.....	24504 lbf

Weight of components

Engine	1129 lbs
Hydraulic pump.....	306 lbs
Attachment control valve	412 lbs
Swing motor and reduction gear assembly	886 lbs
Travel motor and reduction gear assembly	805 lbs
Boom cylinder.....	518 lbs
Dipper cylinder.....	738 lbs
Bucket cylinder	428 lbs
Counterweight	11905 lbs
Cab	560 lbs
Turntable	1197 lbs
Upperstructure assembly.....	24052 lbs
Hydraulic swivel.....	68 lbs
Frame assembly	25596 lbs
Machine without attachment.....	50860 lbs
Attachment	11618 lbs
Boom assembly.....	5710 lbs
Dipper assembly.....	3461 lbs
Radiator and oil-cooler assembly	364 lbs
Fuel reservoir.....	192 lbs
Hydraulic reservoir.....	280 lbs
Idler wheel	340 lbs
Upper roller.....	97 lbs
Lower roller.....	132 lbs
Tension damper.....	1096 lbs
23.6 in track	4828 lbs
27.5 in track	5260 lbs
31.4 in track	5688 lbs



Suggest:

If the above button click is invalid.

Please download this document

first, and then click the above link

to download the complete manual.

Thank you so much for reading

DIMENSIONS AND WEAR LIMIT OF THE TRACK ASSEMBLY

Sprocket

Dimensions

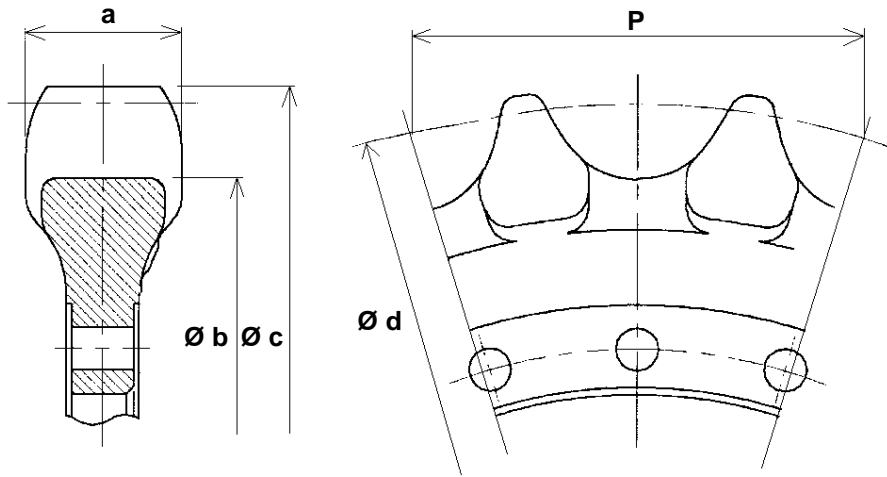

CS01B512

Mark		Dimension (in)
a	Standard	3.26
	Limit	2.87
Ø b	Standard	26
	Limit	25.5
Ø c	Standard	29.4
	Limit	29
Ø d	Standard	28.8
	Limit	---
P	Standard	8.4
	Limit	---

Gauge

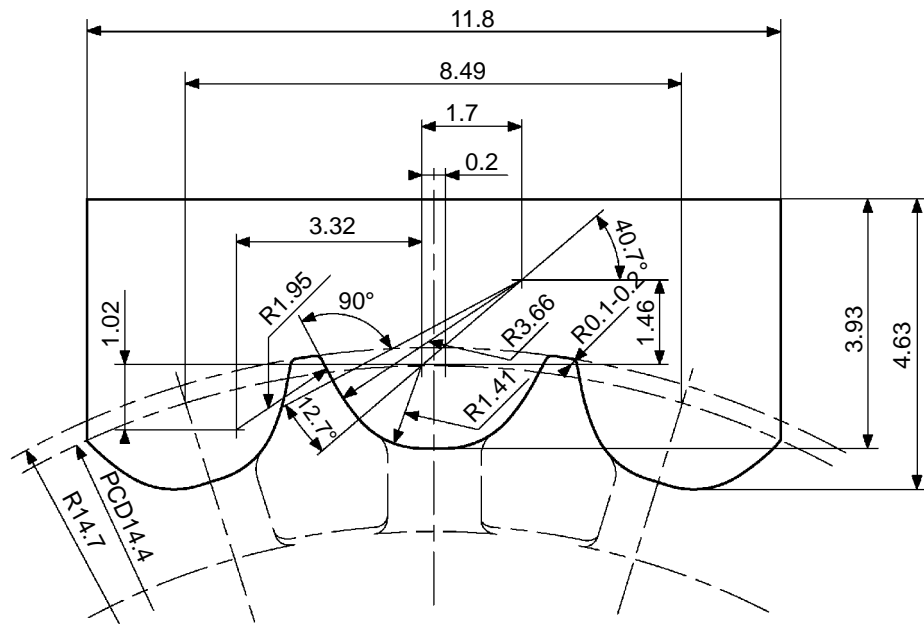

Idler wheel

Dimensions

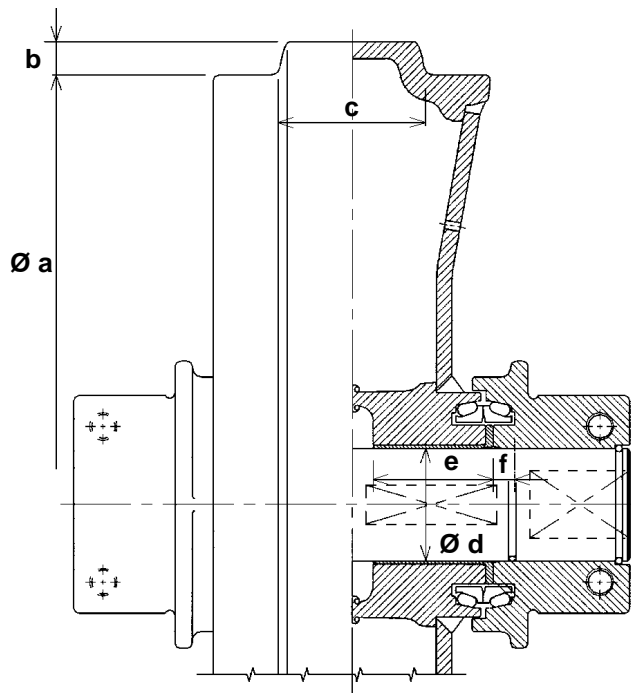

Mark		Dimension (in)
$\varnothing a$	Standard	22
	Limit	21.6
b	Standard	0.88
	Limit	---
c	Standard	4.01
	Limit	3.62
$\varnothing d$ (shaft)	Standard	3.34
	Limit	3.30
$\varnothing d$ (bushing)	Standard	3.34
	Limit	3.38
e	Standard	3.22
	Limit	3.18
f	Standard	0.94
	Limit	0.92

CS01B514

Gauge

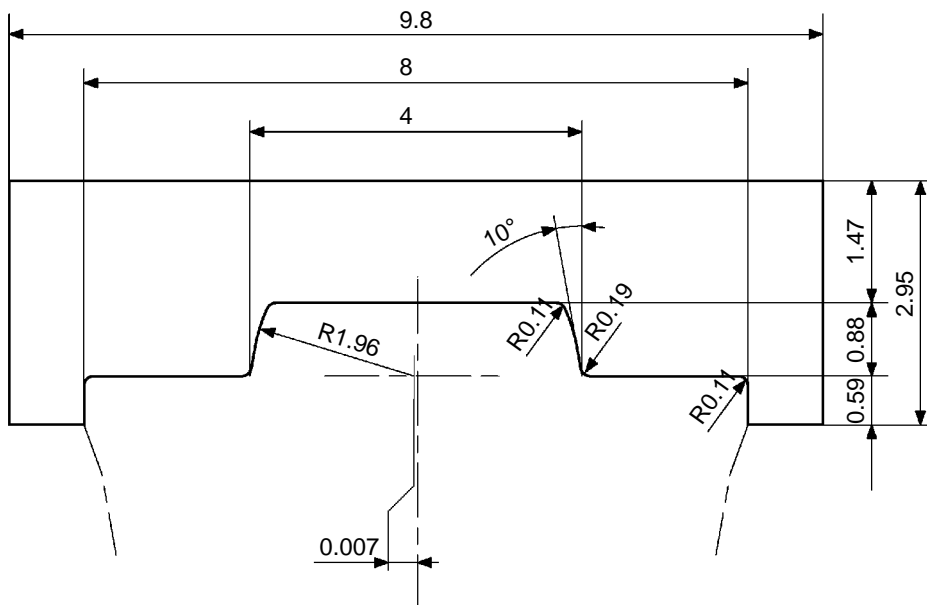

CI01N502

<https://www.ebooklibonline.com>

Hello dear friend!

Thank you very much for reading.

Enter the link into your browser.

The full manual is available for immediate download.

<https://www.ebooklibonline.com>