

CX60C
Mini Excavator

SERVICE MANUAL

Part number 51452136
English
July 2018
Replaces part number 48114831



Contents

INTRODUCTION

Engine.....	10
[10.001] Engine and crankcase	10.1
[10.106] Valve drive and gears	10.2
[10.101] Cylinder heads	10.3
[10.105] Connecting rods and pistons.....	10.4
[10.103] Crankshaft and flywheel.....	10.5
[10.216] Fuel tanks	10.6
[10.206] Fuel filters	10.7
[10.218] Fuel injection system.....	10.8
[10.202] Air cleaners and lines	10.9
[10.254] Intake and exhaust manifolds and muffler	10.10
[10.501] Exhaust Gas Recirculation (EGR) exhaust treatment.....	10.11
[10.400] Engine cooling system	10.12
[10.414] Fan and drive	10.13
[10.304] Engine lubrication system.....	10.14
Hydraulic systems.....	35
[35.000] Hydraulic systems.....	35.1
[35.300] Reservoir, cooler, and filters.....	35.2
[35.106] Variable displacement pump	35.3
[35.359] Main control valve.....	35.4
[35.357] Pilot system	35.5
[35.355] Hydraulic hand control	35.6
[35.356] Hydraulic foot control.....	35.7
[35.352] Hydraulic swing system	35.8
[35.353] Hydraulic travel system	35.9
[35.354] Hydraulic central joint	35.10

[35.736] Boom hydraulic system	35.11
[35.737] Dipper hydraulic system.....	35.12
[35.738] Excavator and backhoe bucket hydraulic system.....	35.13
[35.734] Tool quick coupler hydraulic system	35.14
[35.360] Hammer and rotating bucket hydraulic system	35.15
[35.739] Swing arm hydraulic system	35.16
[35.741] Dozer blade cylinders	35.17
Frames and ballasting	39
[39.140] Ballasts and supports	39.1
Tracks and track suspension.....	48
[48.130] Track frame and driving wheels.....	48.1
[48.100] Tracks	48.2
[48.134] Track tension units	48.3
[48.138] Track rollers	48.4
Cab climate control	50
[50.100] Heating.....	50.1
[50.200] Air conditioning.....	50.2
Electrical systems	55
[55.000] Electrical system	55.1
[55.100] Harnesses and connectors.....	55.2
[55.525] Cab engine controls.....	55.3
[55.015] Engine control system.....	55.4
[55.201] Engine starting system	55.5
[55.301] Alternator.....	55.6
[55.302] Battery.....	55.7
[55.011] Fuel tank system	55.8
[55.014] Engine intake and exhaust system.....	55.9
[55.012] Engine cooling system	55.10

<https://www.ebooklibonline.com>

Hello dear friend!

Thank you very much for reading.

Enter the link into your browser.

The full manual is available for immediate download.

<https://www.ebooklibonline.com>

[55.013] Engine oil system	55.11
[55.640] Electronic modules	55.12
[55.512] Cab controls	55.13
[55.036] Hydraulic system control	55.14
[55.524] Cab controls (Lift arm, Boom, Dipper, Bucket)	55.15
[55.518] Wiper and washer system	55.16
[55.404] External lighting	55.17
[55.514] Cab lighting	55.18
[55.408] Warning indicators, alarms, and instruments	55.19
[55.DTC] FAULT CODES	55.20
Booms, dippers, and buckets	84
[84.910] Boom	84.1
[84.912] Dipper arm	84.2
[84.100] Bucket	84.3
Dozer blade and arm	86
[86.110] Dozer blade	86.1
Platform, cab, bodywork, and decals	90
[90.150] Cab	90.1
[90.120] Mechanically-adjusted operator seat	90.2
[90.100] Engine hood and panels	90.3
[90.105] Machine shields and guards	90.4



INTRODUCTION

Foreword - Important notice regarding equipment servicing

All repair and maintenance work listed in this manual must be carried out only by qualified dealership personnel, strictly complying with the instructions given, and using, whenever possible, the special tools.

Anyone who performs repair and maintenance operations without complying with the procedures provided herein shall be responsible for any subsequent damages.

The manufacturer and all the organizations of its distribution chain, including - without limitation - national, regional, or local dealers, reject any responsibility for damages caused by parts and/or components not approved by the manufacturer, including those used for the servicing or repair of the product manufactured or marketed by the manufacturer. In any case, no warranty is given or attributed on the product manufactured or marketed by the manufacturer in case of damages caused by parts and/or components not approved by the manufacturer.

The manufacturer reserves the right to make improvements in design and changes in specifications at any time without notice and without incurring any obligation to install them on units previously sold. Specifications, descriptions, and illustrative material herein are as accurate as known at time of publication but are subject to change without notice.

In case of questions, refer to your CASE CONSTRUCTION Sales and Service Networks.

Safety rules

Personal safety





This is the safety alert symbol. It is used to alert you to potential personal injury hazards. Obey all safety messages that follow this symbol to avoid possible death or injury.

Throughout this manual you will find the signal words DANGER, WARNING, and CAUTION followed by special instructions. These precautions are intended for the personal safety of you and those working with you.

Read and understand all the safety messages in this manual before you operate or service the machine.

 DANGER indicates a hazardous situation that, if not avoided, will result in death or serious injury.

 WARNING indicates a hazardous situation that, if not avoided, could result in death or serious injury.

 CAUTION indicates a hazardous situation that, if not avoided, could result in minor or moderate injury.

FAILURE TO FOLLOW DANGER, WARNING, AND CAUTION MESSAGES COULD RESULT IN DEATH OR SERIOUS INJURY.

Machine safety

NOTICE: Notice indicates a situation that, if not avoided, could result in machine or property damage.

Throughout this manual you will find the signal word Notice followed by special instructions to prevent machine or property damage. The word Notice is used to address practices not related to personal safety.

Information

NOTE: Note indicates additional information that clarifies steps, procedures, or other information in this manual.

Throughout this manual you will find the word Note followed by additional information about a step, procedure, or other information in the manual. The word Note is not intended to address personal safety or property damage.

Safety rules - General information

Cleaning

Clean the metal parts with cleaning solution that meets the standard and steam cleaning. (except for bearings)

After cleaning, dry well, and inject oil in all parts.

Also inject oil into the bearings after drying.

Inspection

When disassembling parts, check all the parts.

If there are any worn or damaged parts, replace them.

Inspect carefully to prevent initial breakdowns.

Bearing

Replace any loose bearings.

Air dry bearings before installing them.

Needle bearing

When inserting needle bearings, be very careful not to damage them.

Apply grease to the section where the needle bearing will be inserted.

Gear

Check that there is no wear and no damage.

Oil seal, O-ring, gasket

Always install new oil seals, O-rings, and gaskets.

Apply grease to sections where oil seals and O-rings will be inserted.

Shaft

Check that there is no wear and no damage.

Check the bearings and check for damaged oil seals on the shaft.

Service parts

Install CASE CONSTRUCTION genuine service parts.

When placing an order, check the parts catalog. It contains the CASE CONSTRUCTION genuine part numbers.

Any breakdowns arising from the installation of non-genuine parts are not covered by the warranty.

Lubricants (fuel, hydraulic oil)

Use the oil from the specified company or specified in the operator's manual or service Manual.

Any breakdowns arising from any fuel or hydraulic oil other than those specified are not covered by the warranty.

Safety rules - Personal safety

Preliminary warnings to maintenance operation

⚠ WARNING

Avoid injury!

Shut off the engine, remove the key, and make sure all machine motion stops before you service the machine.

Failure to comply could result in death or serious injury.

W1128B

⚠ WARNING

Improper operation or service of this machine can result in an accident.

Assign a supervisor to direct worksite operations. Agree on all safety measures, procedures, and suitable hand signals.

Failure to comply could result in death or serious injury.

W0287A

⚠ CAUTION

Pinch hazard!

Always use suitable tools to align mating parts. DO NOT use your hand or fingers.

Failure to comply could result in minor or moderate injury.

C0044A

Personal Protective Equipment (PPE)

⚠ WARNING

Avoid injury!

Use Personal Protective Equipment (PPE), including protective goggles, gloves, and safety footwear.

Failure to comply could result in death or serious injury.

W1036A

Lifting operation

⚠ WARNING

Crushing hazard!

The lifting systems must be operated by qualified personnel who are aware of the correct procedures to follow. Make sure all lifting equipment is in good condition, and all hooks are equipped with safety latches.

Failure to comply could result in death or serious injury.

W0256A

⚠ WARNING

Heavy objects!

Lift and handle all heavy components using lifting equipment with adequate capacity. Always support units or parts with suitable slings or hooks. Make sure the work area is clear of all bystanders.

Failure to comply could result in death or serious injury.

W0398A

⚠ WARNING

Improper operation or service of this machine can result in an accident.

Raised equipment or machine movement without an operator can cause serious injury. Always do the following before performing any maintenance:

Park the machine on flat, level ground.

Lower the attachment to the ground.

Shut down the engine and remove the ignition key.

Lock the tracks.

Failure to comply could result in death or serious injury.

W0944D

⚠ WARNING

Tip-over hazard!
Only raise the track as little as necessary.
Failure to comply could result in death or serious injury.

W0276A

Hydraulic system

⚠ WARNING

Burn hazard!
Before performing any service on the hydraulic system, you must allow it to cool. Hydraulic fluid temperature should not exceed 40 °C (104 °F).
Failure to comply could result in death or serious injury.

W0241A

⚠ WARNING

Pressurized fluid can penetrate the skin and cause severe injuries.
The grease in the cylinder is under high pressure. Never loosen the grease fitting adaptor completely in order to speed up the flow of grease.
Failure to comply could result in death or serious injury.

W0261A

⚠ WARNING

Pressurized system!
Before attempting any service procedure, it is your responsibility to know the number of accumulators on the machine, and the correct procedure for releasing the pressure of each accumulator.
Failure to comply could result in death or serious injury.

W0136A

Battery

⚠ WARNING

Battery acid causes burns. Batteries contain sulfuric acid.
Avoid contact with skin, eyes or clothing. Antidote (external): Flush with water. Antidote (eyes): flush with water for 15 minutes and seek medical attention immediately. Antidote (internal): Drink large quantities of water or milk. Do not induce vomiting. Seek medical attention immediately.
Failure to comply could result in death or serious injury.

W0111A

⚠ WARNING

Battery gas can explode!
To prevent an explosion: 1. Always disconnect the negative (-) battery cable first. 2. Always connect the negative (-) battery cable last. 3. Do not short circuit the battery posts with metal objects. 4. Do not weld, grind, or smoke near a battery.
Failure to comply could result in death or serious injury.

W0011A

Fluids

⚠ WARNING

Hazardous chemicals!
Coolant can be toxic. Avoid contact with skin, eyes, and clothing. Antidotes:
EXTERNAL - Rinse thoroughly with water. Remove soiled clothing.
INTERNAL - Rinse the mouth with water. DO NOT induce vomiting. Seek immediate medical attention.
EYES - Flush with water. Seek immediate medical attention.
Failure to comply could result in death or serious injury.

W0282A



SERVICE MANUAL

Engine

Engine - Remove

⚠ WARNING

Avoid injury!

Shut off the engine, remove the key, and make sure all machine motion stops before you service the machine.

Failure to comply could result in death or serious injury.

W1128B

⚠ WARNING

Chemical hazard!

Use caution when opening the quick coupler cap from the load port. There may be product left in the port.

Failure to comply could result in death or serious injury.

W1039A

⚠ WARNING

Crushing hazard!

The lifting systems must be operated by qualified personnel who are aware of the correct procedures to follow. Make sure all lifting equipment is in good condition, and all hooks are equipped with safety latches.

Failure to comply could result in death or serious injury.

W0256A

⚠ WARNING

Heavy objects!

Lift and handle all heavy components using lifting equipment with adequate capacity. Always support units or parts with suitable slings or hooks. Make sure the work area is clear of all bystanders.

Failure to comply could result in death or serious injury.

W0398A

⚠ WARNING

Burn hazard!

Before performing any service on the hydraulic system, you must allow it to cool. Hydraulic fluid temperature should not exceed 40 °C (104 °F).

Failure to comply could result in death or serious injury.

W0241A

⚠ WARNING

Escaping fluid!

Hydraulic fluid or diesel fuel leaking under pressure can penetrate the skin and cause infection or other injury. To prevent personal injury: Relieve all pressure before disconnecting fluid lines or performing work on the hydraulic system. Before applying pressure, make sure all connections are tight and all components are in good condition. Never use your hand to check for suspected leaks under pressure. Use a piece of cardboard or wood for this purpose. If injured by leaking fluid, see your doctor immediately.

Failure to comply could result in death or serious injury.

W0178A

⚠ WARNING

Chemical hazard!

When handling fuel, lubricants, and other service chemicals, follow the manufacturer's instructions. Wear Personal Protective Equipment (PPE) as instructed. Do not smoke or use open flame. Collect fluids in proper containers. Obey all local and environmental regulations when disposing of chemicals.

Failure to comply could result in death or serious injury.

W0371A

1. Set the battery disconnect switch to O position (OFF position) to cut off any power supply in the electrical system of the machine. For details, see **Mechanical battery isolator - Dynamic description (55.302)**.
2. Tilting the cab (refer to **Cab tilting system - Service instruction (90.150)**)
3. Discharge the air conditioning system (refer to **Air conditioning - Discharging (50.200)**)
4. Remove the counterweight (refer to **Counterweight - Remove (39.140)**)
5. Remove the engine hood (refer to **Engine hood - Remove (90.105)**)
6. Remove the exhaust muffler (refer to **Exhaust muffler - Remove (10.254)**)
7. Use a wrench [**13 mm**] to remove the six bolts (1) and then remove the under cover (2) engine.

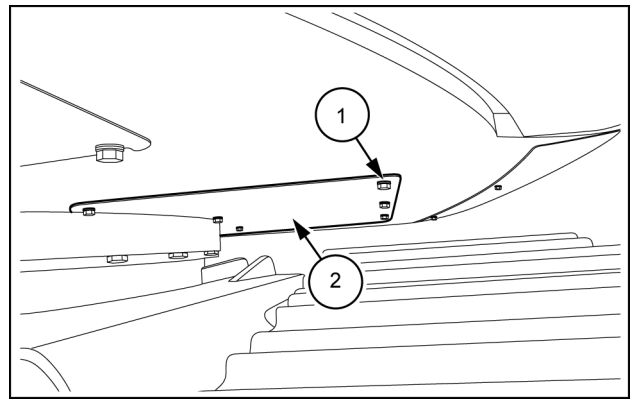

SMIL16MEX3700AB 1

8. Use a wrench [**17 mm**] to remove the two bolts (3), and then remove the battery panel (4).

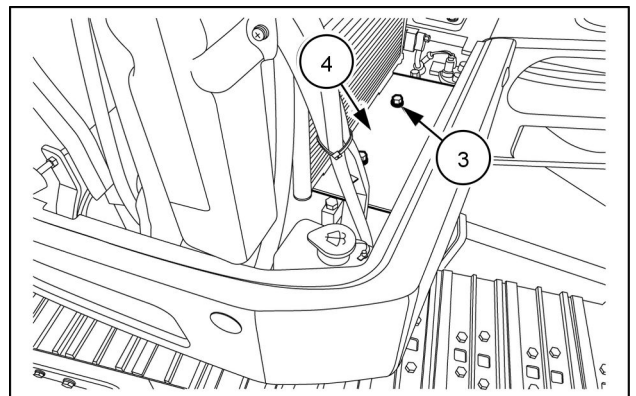

SMIL16MEX1101AB 2

9. Remove the protective caps.
10. Use a wrench [**13 mm**] to remove the seven bolts (1), and then remove the right-hand side panel (2).

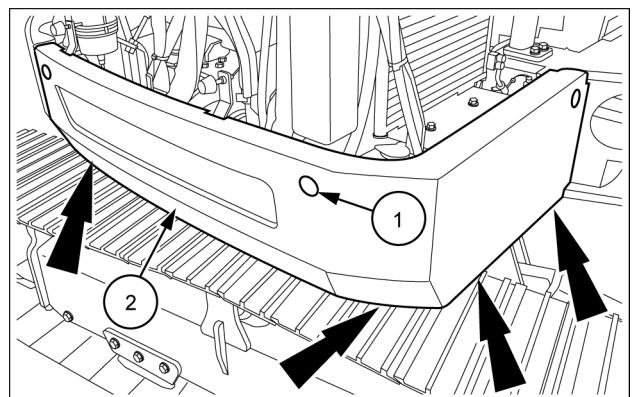

SMIL16MEX3680AB 3

11. Cut-off the negative-terminal cable (-) **(2)**.
Next, cut-off the positive-terminal cable (+) **(1)**.

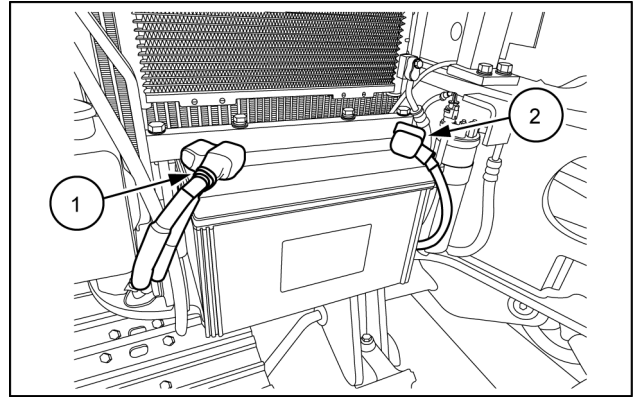

SMIL16MEX3701AB 4

12. Use a wrench [**17 mm**] to remove the bolt **(1)** and then separate the bracket engine hood **(2)** from the oil reservoir.
13. Use a wrench [**19 mm**] to remove the four bolts **(3)**.

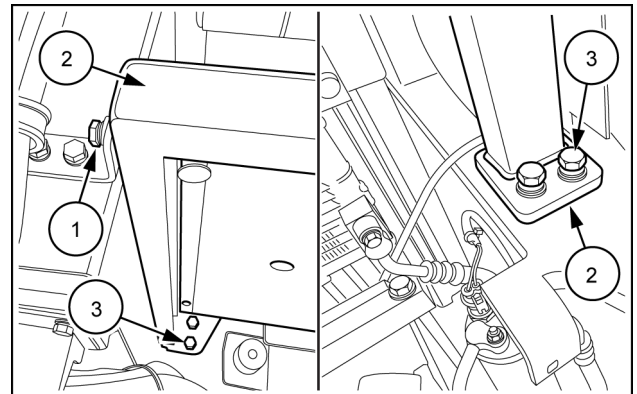

SMIL16MEX3698AB 5

14. Install the two hooks into the lift bracket engine hood, and then use the wire rope or chain and lift-crane to secure the bracket engine hood.
15. Remove the bracket engine hood **(1)**.

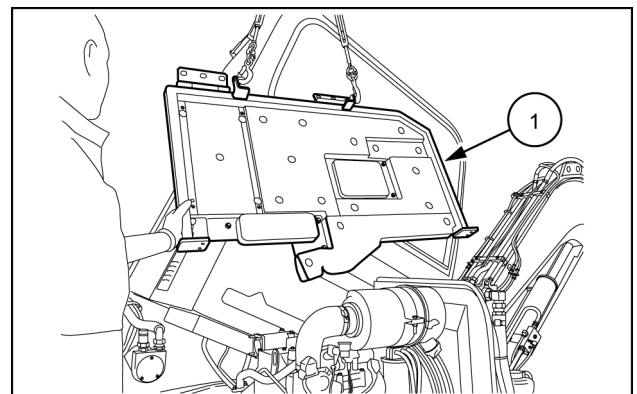

SMIL16MEX3699AB 6

16. Use a wrench [**19 mm**] to remove the three bolts **(1)** then remove the fan-guard **(2)**.

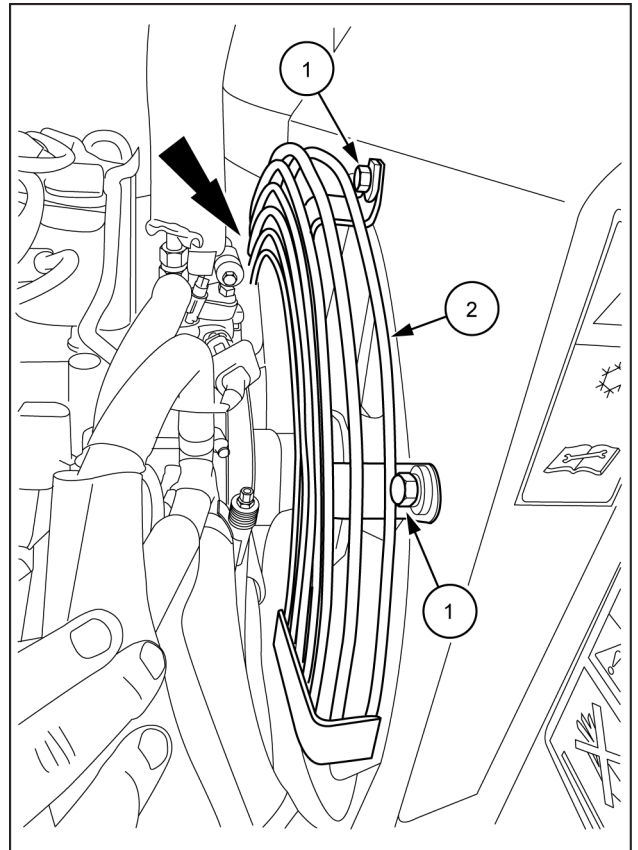

SMIL16MEX3684BB 7

17. Loosen the clamps and remove the cab heating hoses **(1)**.

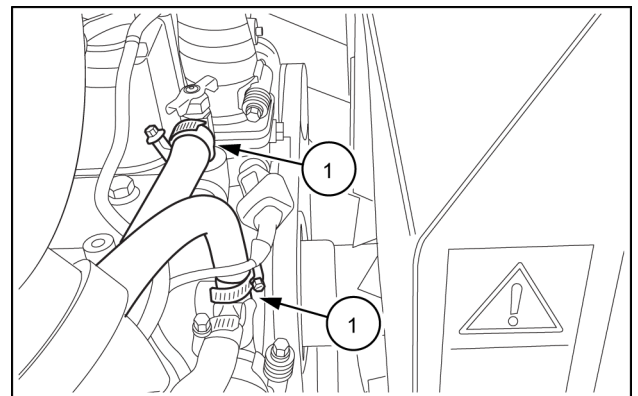

SMIL16MEX3702AB 8

18. Use a wrench [**13 mm**] to remove the two bolts (1) and then remove the screen (2).

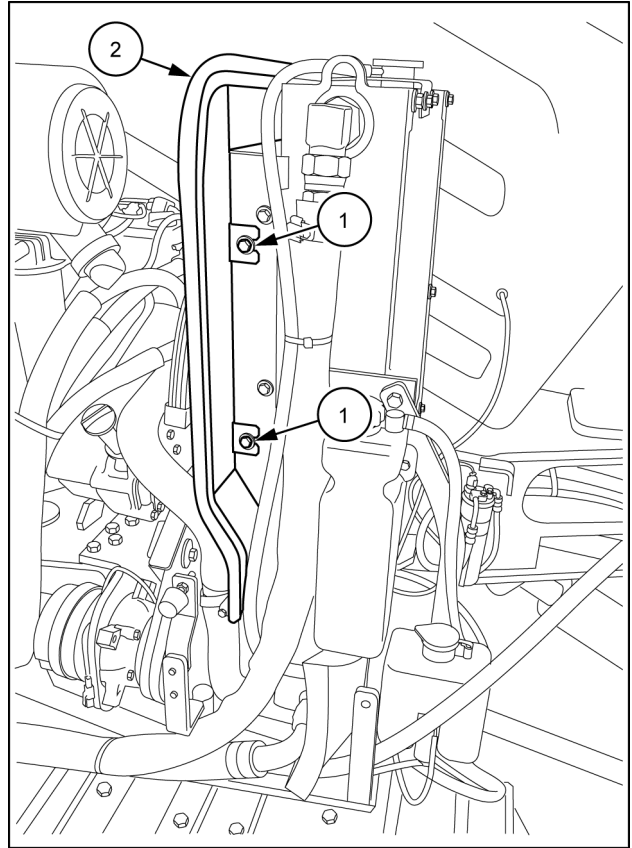

SMIL16MEX3703BB 9

19. Use a wrench [**13 mm**] to remove the two bolts (1) and then remove the top screen (2).
20. Loosen the clamp to disconnect the cooling hose (3) from the radiator.

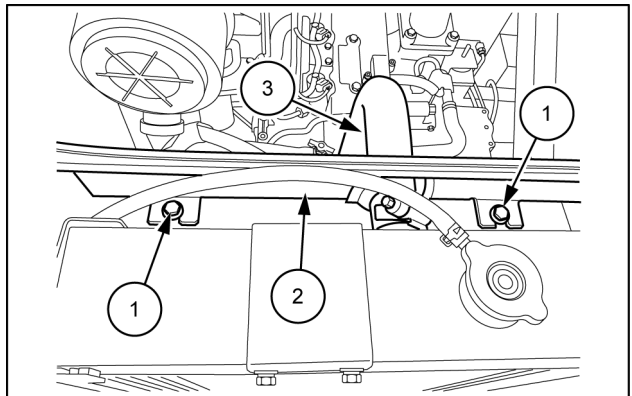

SMIL16MEX3704AB 10

21. Loosen the clamp (1) to disconnect the cooling hose (2) from the radiator.

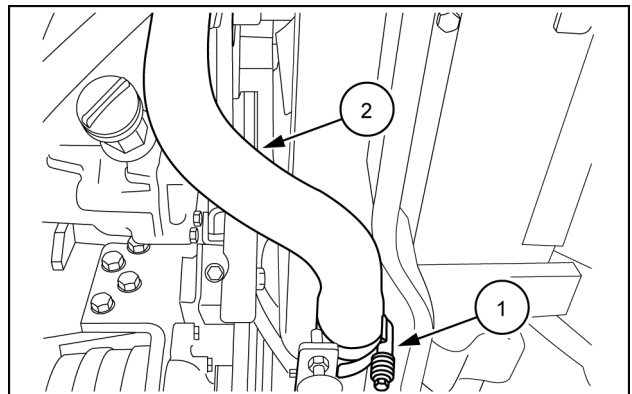

SMIL16MEX3705AB 11

22. Loosen the clamp and remove the fuel hose (1) from the fuel filter (2).

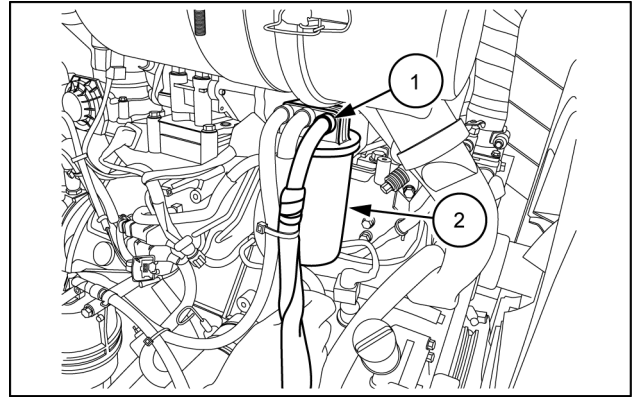

SMIL16MEX3706AB 12

23. Close the fuel pre-filter cock (1).
 24. Loosen the clamp and remove the fuel pre-filter hose (2) from the fuel pre-filter (3).
 25. Use a wrench [13 mm] to loosen the bolts (3), and then remove the fuel pre-filter (4).

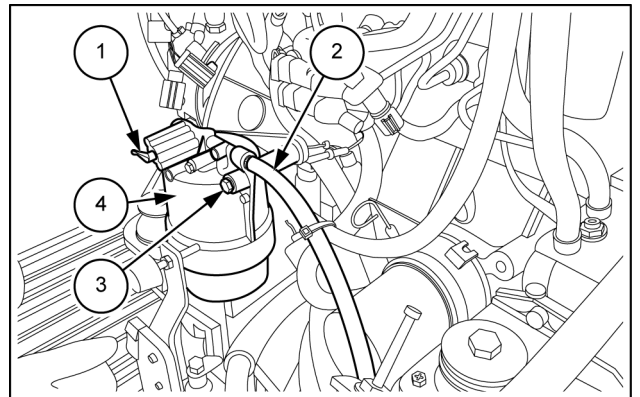

SMIL16MEX3707AB 13

26. Use a wrench [17 mm] to disconnect the two hoses (1) from the air conditioning compressor (4).
 27. Disconnect the electrical connector CN-28 (2) from the air conditioning compressor (4).
 28. Remove the screw then remove the electrical connector (3) from the air conditioning compressor (4).

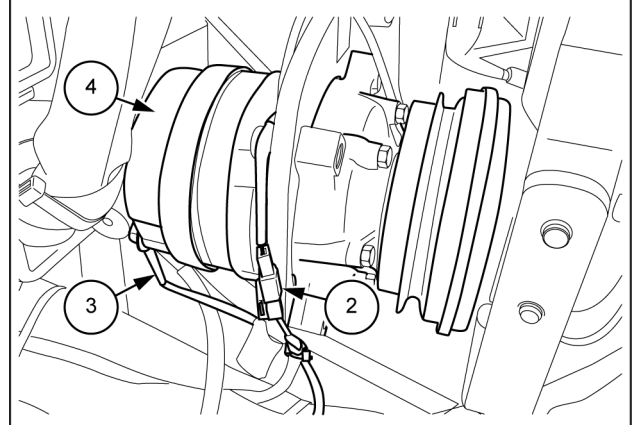
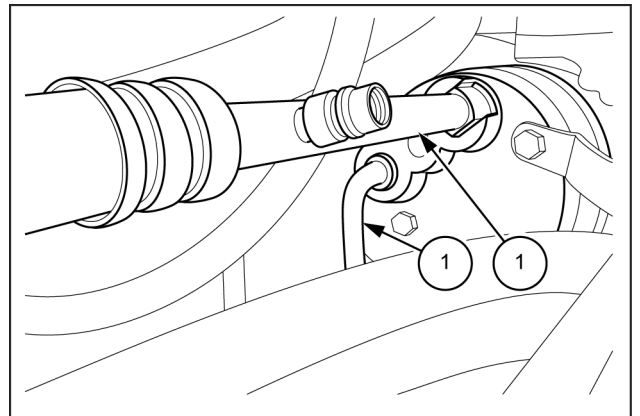

SMIL16MEX3708BB 14

29. Disconnect the electrical connector **CN-145 (1)** of the electrical fuel feed pump.

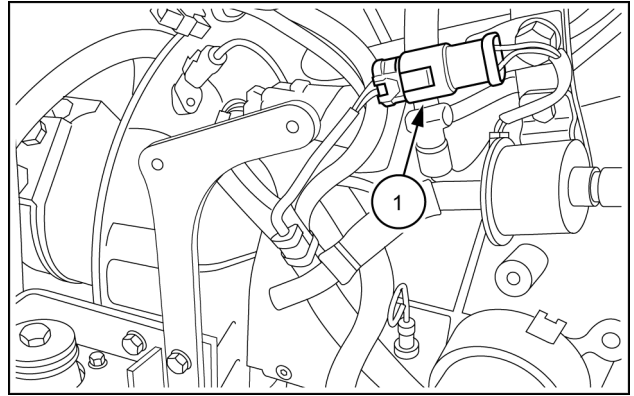

SMIL16MEX3709AB 15

30. Disconnect the electrical connector **CN-302 (1)**.
31. Disconnect the electrical connector **CN-304 (1)**.
32. Disconnect the electrical connector **CN-301 (3)**.
33. Disconnect the electrical connector **CN-303 (4)**.

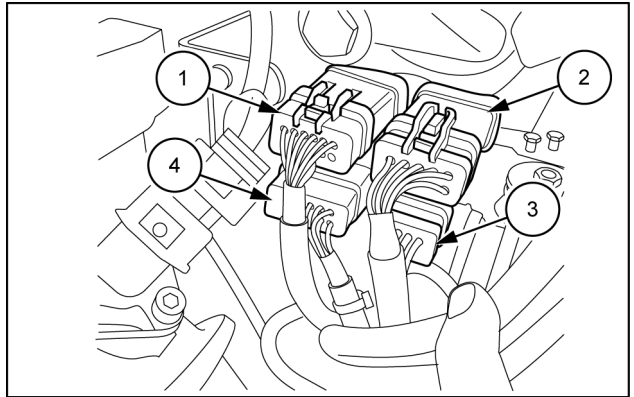

SMIL16MEX3556AB 16

34. Disconnect the electrical connector **CD-18 (1)** of the engine oil pressure.

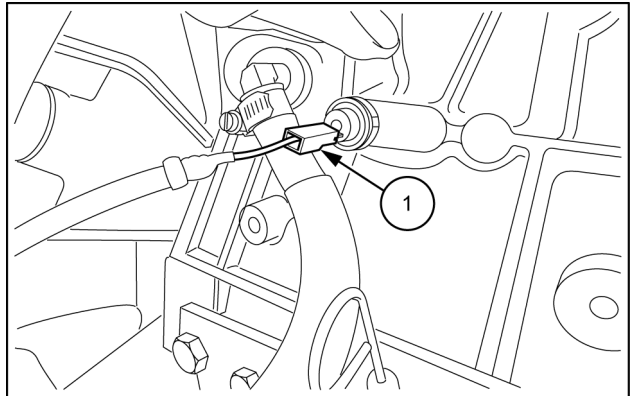

SMIL16MEX3557AB 17

35. Disconnect the electrical connector **CN-80 (1)** of the pre-heater glow plugs.

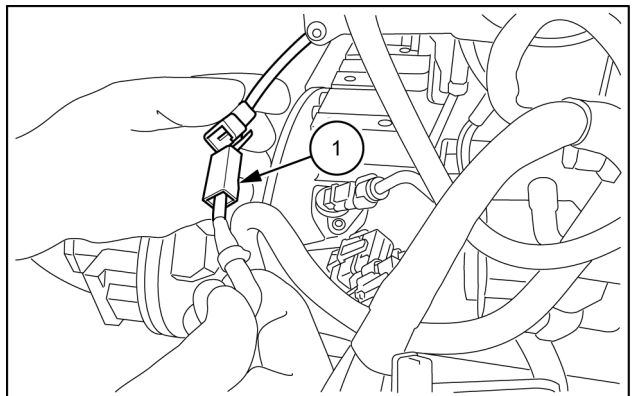

SMIL16MEX3558AB 18

36. Disconnect the electrical connector **CD-10 (1)** from the air cleaner.

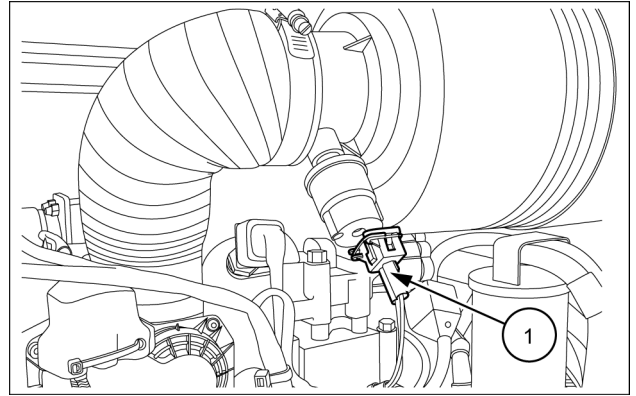

SMIL16MEX3559AB 19

37. Use a wrench [**17 mm**] to remove the bolt and then disconnect the earth strap **(1)** from the engine.

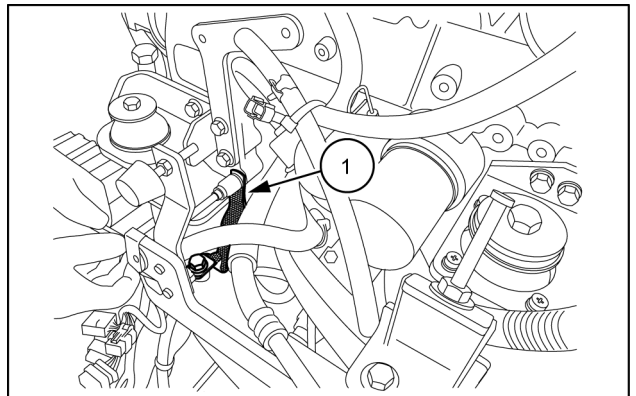

SMIL16MEX3710AB 20

38. Move the cap.
39. Use a wrench [**13 mm**] to remove the nut and disconnect the wire **(1)**.
40. Disconnect the electrical connector **(2)** from the alternator.

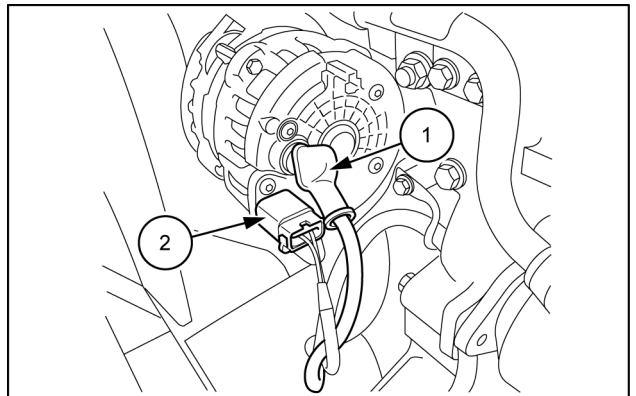

SMIL16MEX3562AB 21

41. Remove the nut to disconnect the wire **(1)**.
42. Move the cap and remove the nut to disconnect the wires **(2)** and **(3)**.

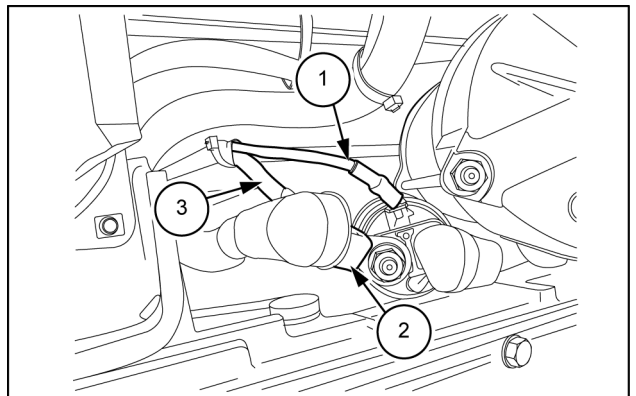

SMIL16MEX3538AB 22

43. Loosen the clamp **(1)** and remove the air hose **(2)** from the air cleaner.

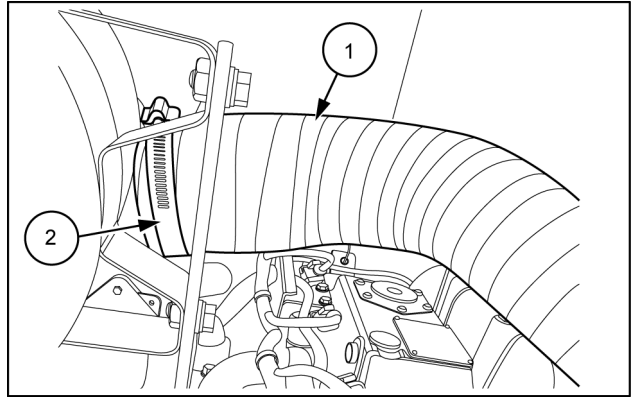

SMIL16MEX3711AB 23

44. Use a wrench [**13 mm**] to remove the four bolts **(1)** and then remove the under cover **(2)** hydraulic oil reservoirs.

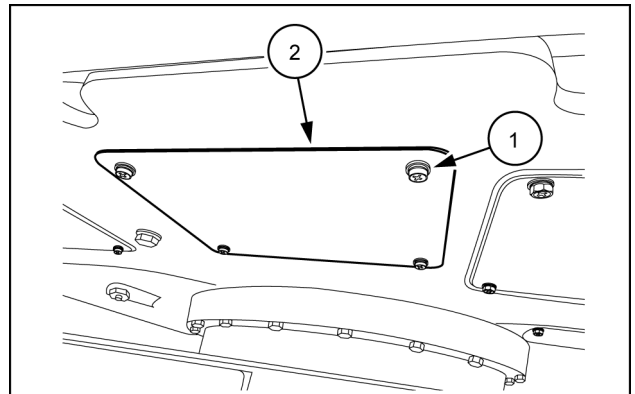

SMIL16MEX3712AB 24

45. Place a receptacle of a suitable capacity under the drain plug **(1)**.

46. Use a wrench [**27 mm**] to remove the drain plug **(1)** located at the bottom of the reservoir **(2)** and drain the hydraulic oil.

47. After draining, close the drain plug **(1)**.

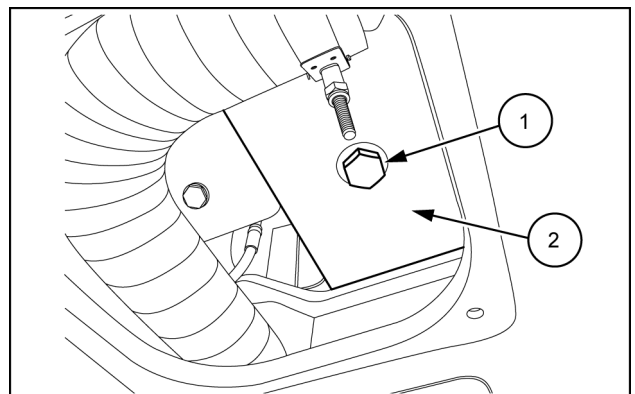

SMIL16MEX3713AB 25

48. Use a wrench [**13 mm**] to remove the four bolts **(1)** and then remove the under cover **(2)** pump.

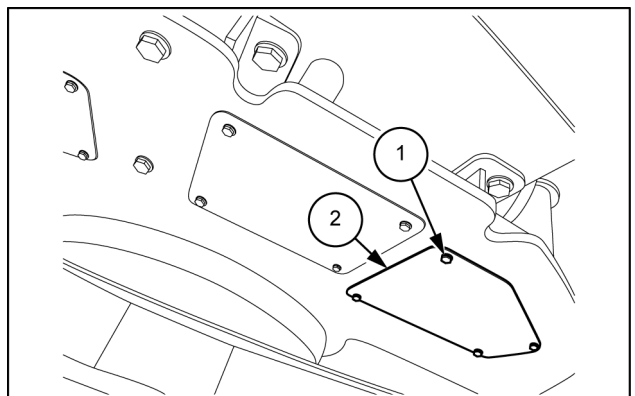

SMIL16MEX3720AB 26

49. Use a wrench [**22 mm**] to disconnect the hose (1) from the filter (2).
50. Mark the pump and hoses so that the connectors match at the time of assembly.
51. Use caps and plugs to cover the hoses to prevent any entry of water, dust or dirt.

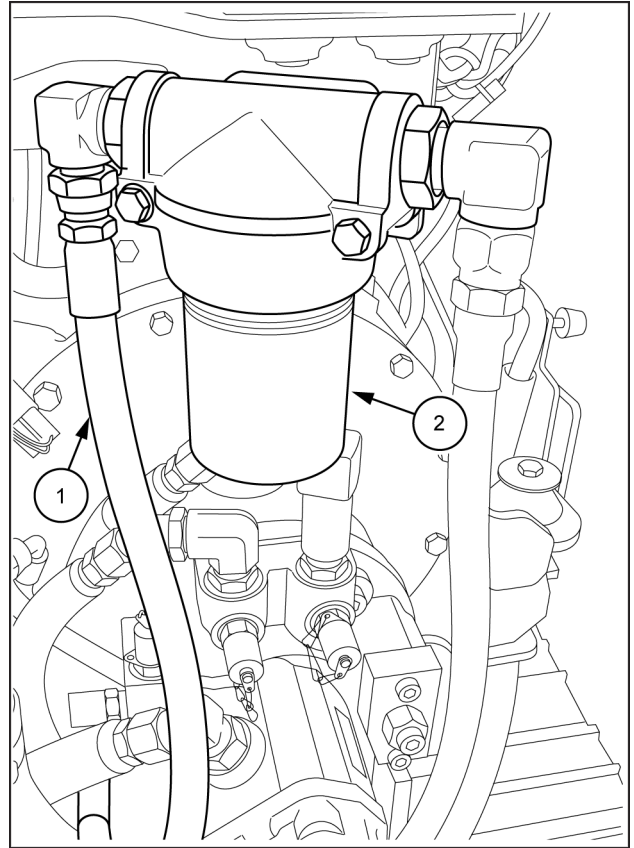

SMIL16MEX3714BB 27

52. Use a wrench [**24 mm**] to disconnect the hoses (1).
53. Mark the pump and hoses so that the connectors match at the time of assembly.
54. Use caps and plugs to cover the pump and hoses to prevent any entry of water, dust or dirt.
55. Clean the pump and hoses by spraying them with a parts cleaner to prevent scratches and prevent dirt from accumulating on the connectors.

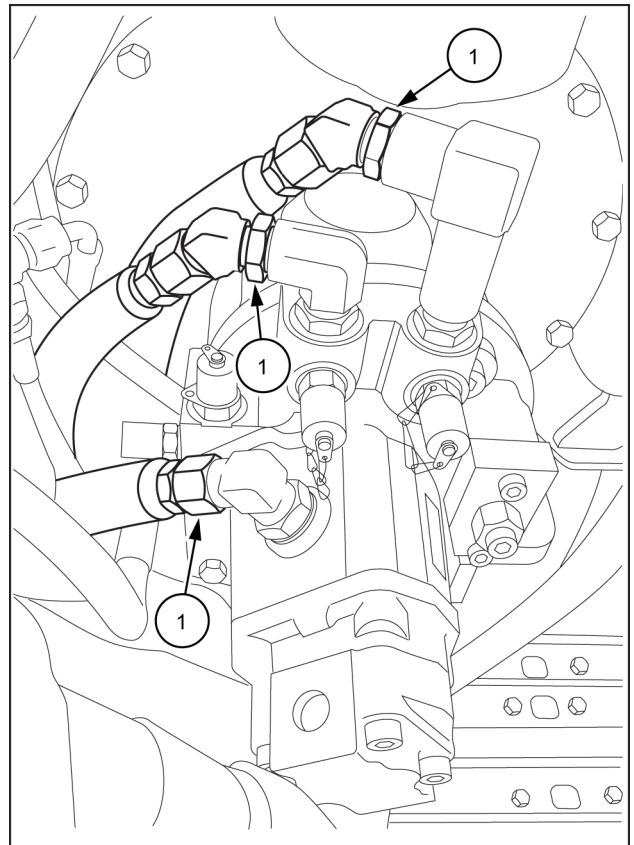

SMIL16MEX3715BB 28

56. Use a hexagon wrench [**10 mm**] to remove the four bolts **(1)** and then separate the suction hose **(2)** from the hydraulic pump.

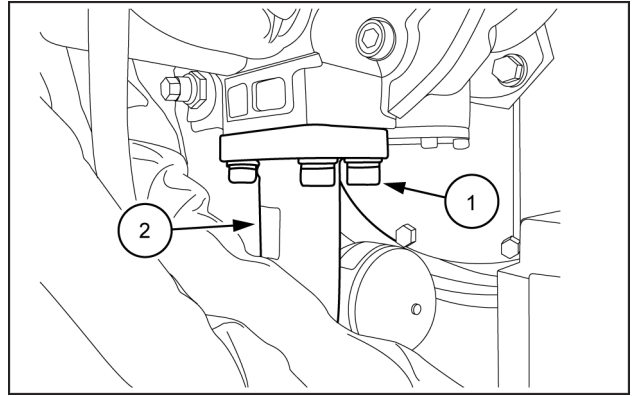

SMIL16MEX3716AB 29

57. Use a wrench [**13 mm**] to remove the six bolts (see arrows) and then remove the fan-shroud **(1)** from the radiator **(2)**.

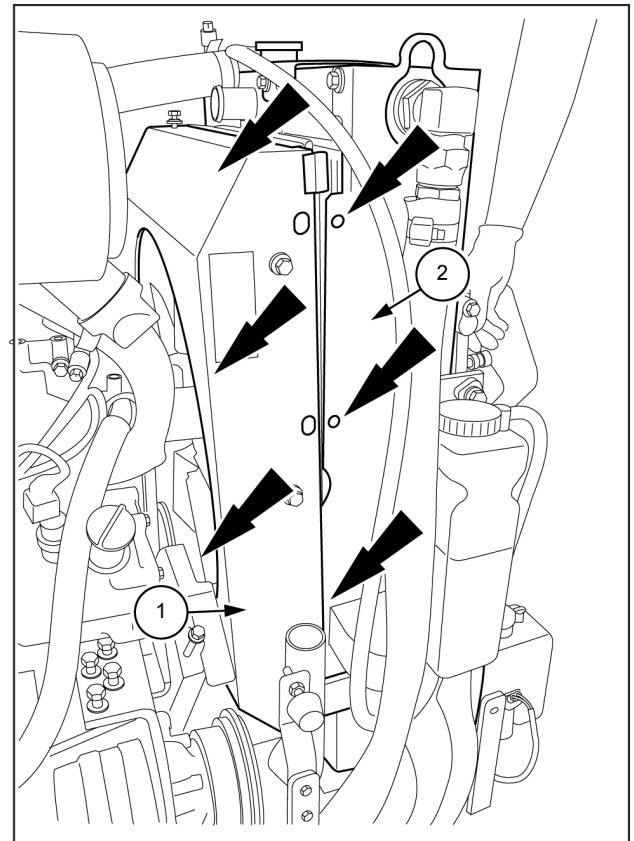

SMIL16MEX3717BB 30

58. Install the two hooks into the engine lift bracket, and then use the wire rope or chain **(3)** and lift-crane to secure the engine.
59. Use a box wrench [**19 mm**] to remove the two bolts **(1)**.
60. Use a box wrench [**24 mm**] to remove the two bolts **(2)**.

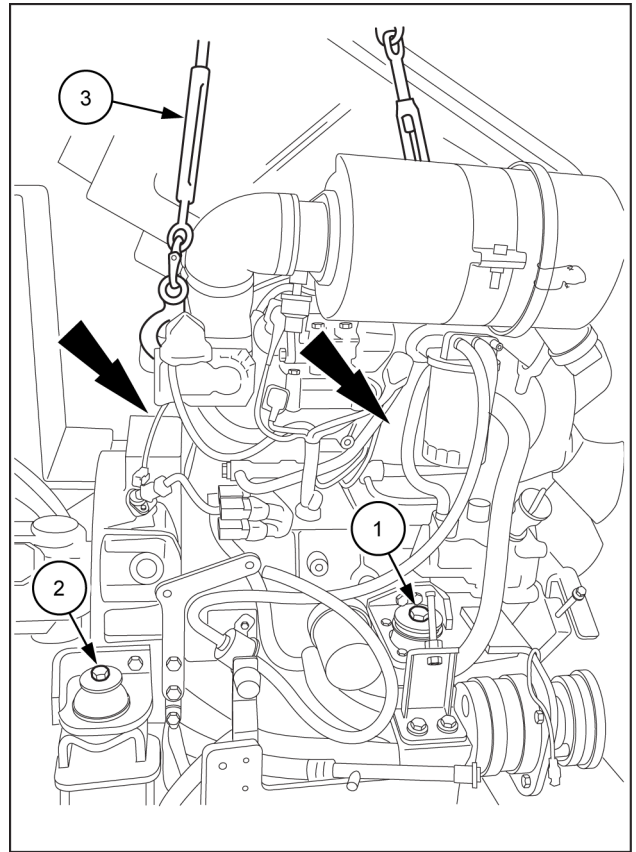

SMIL16MEX3718BB 31

61. Remove the engine **(1)**.
62. On the bench remove the pump and the air conditioning compressor.

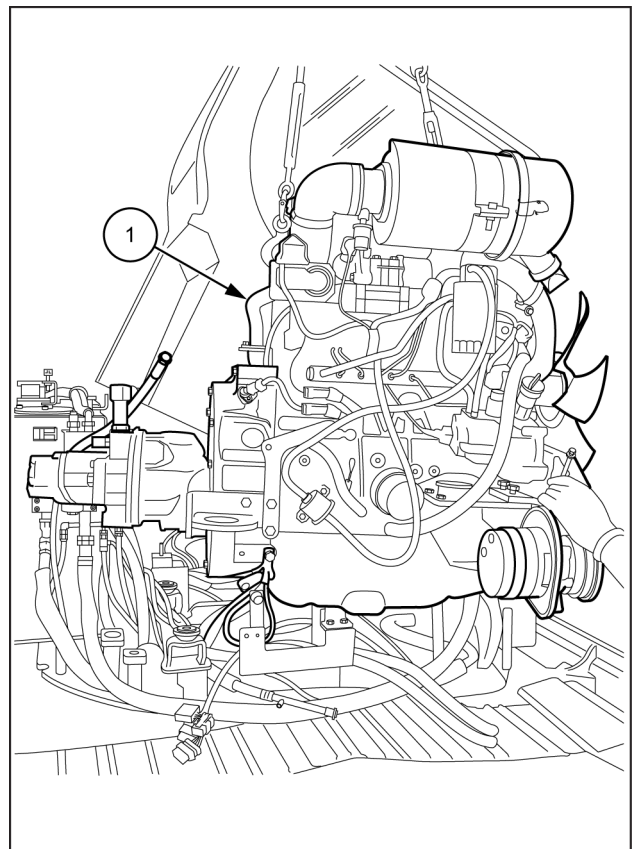

SMIL16MEX3719BB 32

Engine - Disassemble

Prepare a clean, flat working surface on a workbench large enough to accommodate the engine components. Discard all used gaskets, O-rings and seals. Use new gaskets, O-rings and seals on reassembly of engine.

NOTICE: *identify all parts and their location using an appropriate method. It is important that all parts are returned to the same position during the reassembly process.*

If the engine will be completely disassembled, the following preliminary steps should be performed.

1. Disconnect the battery cables at the battery. Always disconnect the negative (-) cable first.
2. Remove the throttle cable, electrical connections, intake and exhaust system connections, and fuel supply lines from the engine.
3. Remove the alternator. (Refer to **Alternator - Remove (55.301)**)
4. Drain the engine coolant from the radiator and cylinder block. Remove the cooling system components from the engine.
5. Remove the engine from the machine. Mount the engine to a suitable engine repair stand having adequate weight capacity.

NOTICE: *be sure to secure the engine solidly to prevent injury or damage to parts due to the engine falling during work on the engine.*

6. Clean the engine by washing with solvent, air or steam cleaning. Carefully operate so as to prevent any foreign matter or fluids from entering the engine or any fuel system or electrical components remaining on the engine.
7. Drain the engine oil into a suitable container. Remove the oil filter.
8. Remove the cylinder head. (Refer to **Cylinder heads - Disassemble (10.101)**)
9. Remove fuel supply pump if necessary. (Refer to **High pressure pump - Remove (10.218)**)
10. Remove the starter motor. (Refer to **Engine starter - Remove (55.201)**)

DISASSEMBLY OF CAMSHAFT AND TIMING COMPONENTS

1. Discard all gaskets, O-rings and seals. Use new gaskets, O-rings and seals on reassembly of the camshaft and timing components.

Gears backlash check

1. Perform the gear backlash check. Refer to **Valve drive and gears - Service instruction - Gears (10.106)**.

Removal of timing gear case cover

1. Remove the bolt and washer retaining the crankshaft pulley.

NOTICE: use care not to damage the threads in the end of the crankshaft when removing the crankshaft pulley.

2. Remove the crankshaft pulley using a gear puller.
3. Remove the bolts that retain the gear case cover (1) to the cylinder block and oil pan.
4. Remove the gear case cover (1).

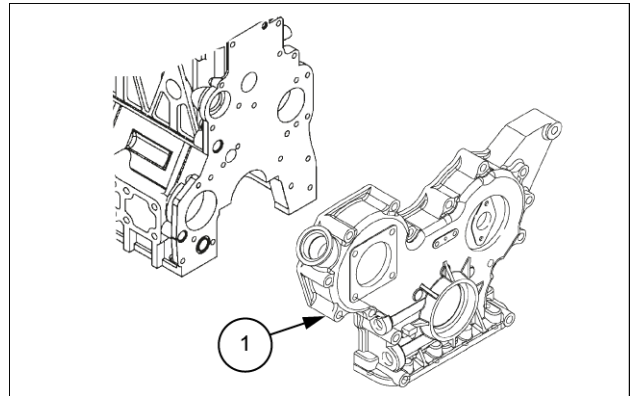

SMIL16MEX3411AB 1

Removal of timing gears

1. Remove the bolts from the idler gear shaft (1). Remove the plate (5), the idler gear shaft (1), the idler gears (2) (4), and bushings (3).
2. Do not remove the crankshaft gear unless it is damaged and requires replacement. If the gear must be removed, remove it using a gear puller.
3. Removal of the camshaft gear requires the camshaft be removed and placed in a press. Do not remove the camshaft gear unless it or the camshaft is damaged and requires replacement. Refer to the removal of the camshaft.

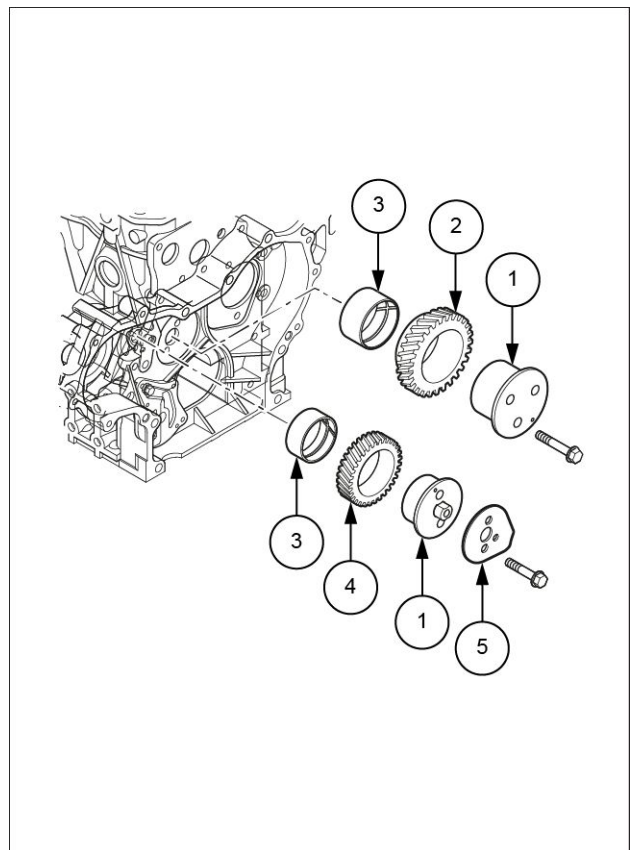

SMIL16MEX3414BB 2

4. Remove the supply pump drive gear using a gear puller.

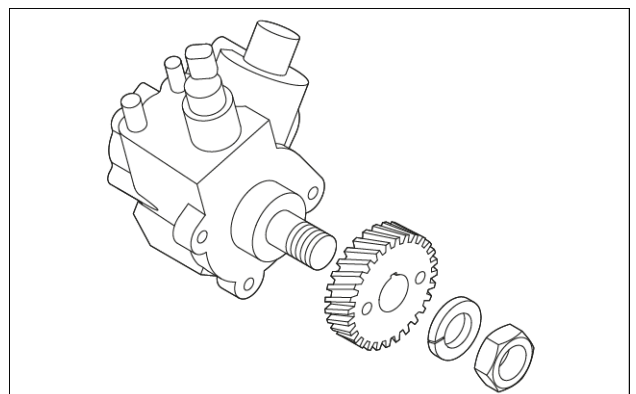

SMIL16MEX3415AA 3

Removal of oil pan

1. Invert the engine (oil pan up) on the engine stand.
2. Remove the oil pan (1).

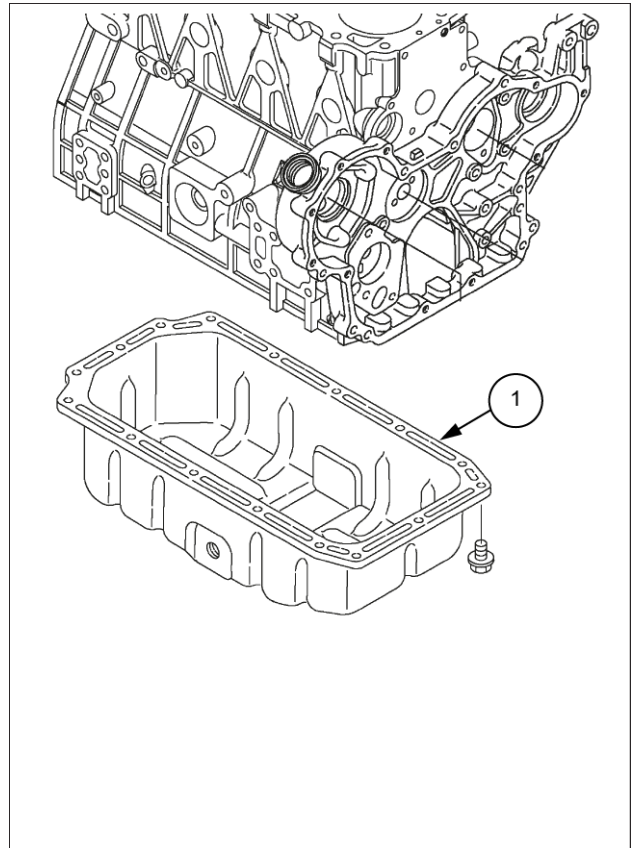

SMIL16MEX3416BB 4

3. Remove the oil pickup tube (1) and O-ring (2).

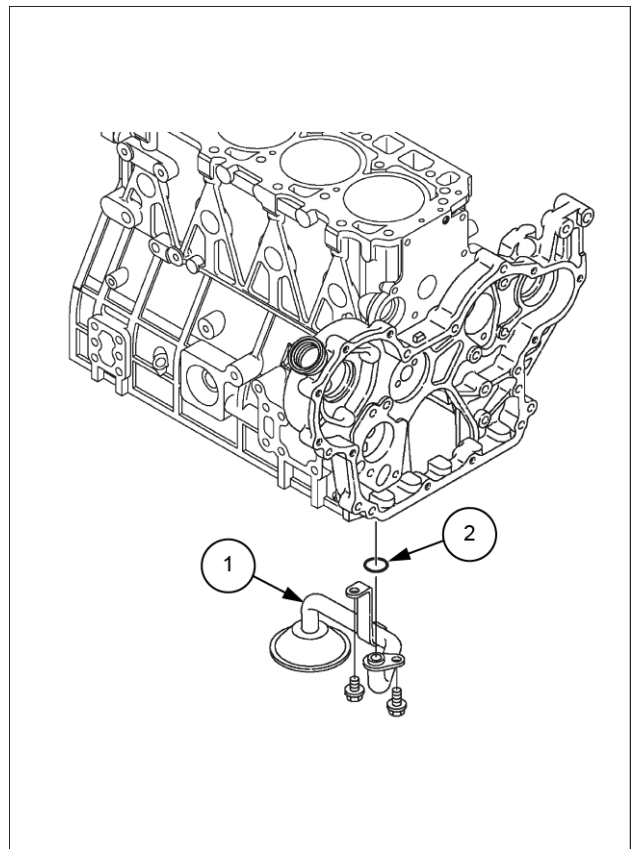

SMIL16MEX3417BB 5

Removal of camshaft

1. Before removing the camshaft, check the camshaft end play.
 - Method A: Install a dial indicator (1) on the cylinder block. Move the camshaft (2) back and forth to measure the end play. Record the measurement. Refer to **Valve drive and gears - Service limits (10.106)** for the service limit.

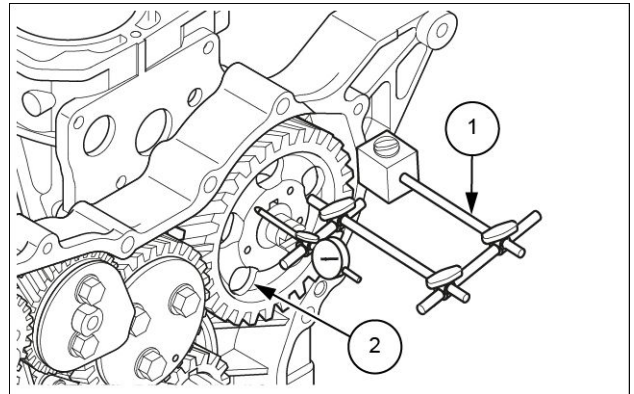

SMIL16MEX3418AB 6

- Method B: Use a feeler gauge to measure the clearance between the thrust plate (1) and front camshaft bearing (2). Refer to **Valve drive and gears - Service limits (10.106)** for the service limit.

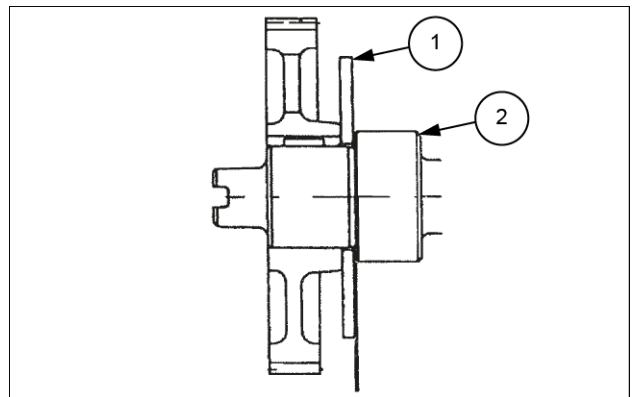

SMIL16MEX3419AB 7

2. Remove the two bolts (3) retaining the camshaft thrust plate (1).
3. Rotate the engine in the engine stand so that gravity causes the tappets (5) to drop away from the camshaft lobes.

NOTE: rotate the camshaft at least two turns to “bump” any sticking tappets away from the camshaft.

4. Slowly pull the camshaft (2) assembly out of the engine being careful not to damage the front camshaft bushing.

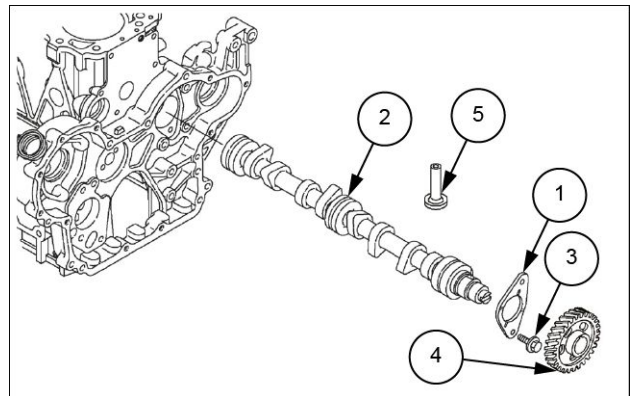

SMIL16MEX3420AB 8

NOTE: if the engine is not installed on an engine repair fixture, stand the engine upright on the flywheel end mounting flange. Rotate the camshaft at least two turns to bump the tappets out of the way to prevent the tappets from interfering with the removal of the camshaft.

The tappets are “mushroom” shaped and must be removed from inside the engine crankcase.

5. Remove the tappets. Mark the tappets so they can be reinstalled in the same location.
6. Remove the camshaft drive gear (4) only if the gear or camshaft require replacement. Use a knife-edge puller and a press to remove the gear. The gear is a shrink-fit and will need to be heated to **180 – 200 °C (356 – 392 °F)** to remove.



Suggest:

If the above button click is invalid.

Please download this document

first, and then click the above link

to download the complete manual.

Thank you so much for reading

Removal of gear case or front plate

NOTE: the camshaft must be removed before removing the gear case. See *Removal of camshaft*.

1. Remove the oil pump.

NOTE: it is not necessary to remove the fuel supply pump from the gear case to remove the gear case. If the fuel supply pump does not need to be repaired, leaving it mounted to the timing gear case will eliminate the need to re-time it during assembly. Refer to **High pressure pump - Remove (10.218)**.

2. Remove the bolt (4).
3. Remove the gear case (1) from the cylinder block. Thoroughly clean all old sealant from the mating surfaces.
4. Inspect and measure the camshaft bushing. Refer to **Valve drive and gears - Service limits (10.106)** for the service limit. If damaged or worn beyond service limits, remove the camshaft bushing (3).
5. Remove two O-rings (2).

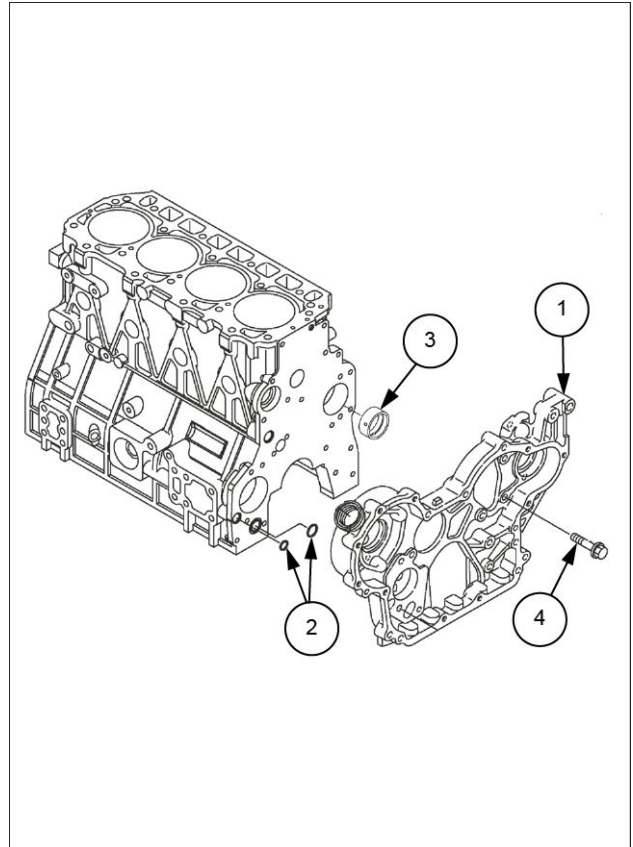

SMIL16MEX3421BB 9

DISASSEMBLY OF CRANKSHAFT AND PISTON COMPONENTS

Removal of pistons

NOTICE: keep the piston pin parts, piston assemblies, and connecting rod assemblies together to be returned to the same position during the reassembly process. Label the parts using an appropriate method.

NOTICE: engines with high operating hours may have a ridge near the top of the cylinders that will catch the piston rings and make it impossible to remove the pistons. Use a suitable ridge reamer to remove ridges and carbon prior to removing the pistons.

NOTE: pistons can fall from cylinder block if the engine is inverted. Rotate the engine so the connecting rods are horizontal before removing the connecting rod caps.

<https://www.ebooklibonline.com>

Hello dear friend!

Thank you very much for reading.

Enter the link into your browser.

The full manual is available for immediate download.

<https://www.ebooklibonline.com>