TO THE READER

This manual has been printed for a skilful engineer to supply the necessary technical information to carry out service operations on this machine.

Carefully read this manual to obtain correct information regarding repair procedures.

For any question or remark, or in case of any error in the contents of this manual, please contact:

CNH ITALIA S.p.A.
Via Plava, 80
10135 TORINO - Italy

REFERENCE

Beyond this Service Manual, also refer to the documents listed below:

- Operator's Manual
- Parts Catalogue

COMPLETE SERVICE MANUAL

The Service Manual consists of one volume:

- CX35B - CX39B - Service Manual "Hydraulic Mini Excavators"

The Service Manual for "Hydraulic Mini Excavators" contains the necessary technical information to carry out maintenance and repair operations on the machine, the necessary tools to carry out maintenance operations, the information on service standards, the procedures for removal, installation, disassembly and reassembly.

The Service Manual relevant to the excavator models **CX35B - CX39B** consists in the following volume, which is identified through the relevant print no. as reported below:

VOLUME	MACHINE TYPE	PRINT NUMBER
Service Manual for "Hydraulic Mini Excavators"	CX35B CX39B	84553645A

SAFETY PRECAUTIONS

GENERAL SAFETY INFORMATION

WARNING

Do not operate or perform any maintenance on this machine until all instructions found in the OPERATOR'S MANUAL have been thoroughly read and understood.

Improper operation or maintenance of this machine may cause accidents and could result in serious injury or death.

Always keep the manual in storage.

If it is missing or damaged, place an order with an authorized dealer/distributor for a replacement.

If you have any questions, please consult an authorized dealer/distributor.

- (1) Most accidents occurring during operation are due to negligence of precautionary measures and safety instructions. Sufficient care should be taken to avoid these accidents. Erroneous operation, lubrication or maintenance services are very dangerous and may cause injury or death of personnel. Therefore all precautionary measures, NOTES, DANGERS, WARNINGS and CAUTIONS contained in this manual and on the machine should be read and understood by all personnel before starting any work with or on the machine.
- (2) Operation, inspection, and maintenance should be carefully carried out, and first priority must be given to safety. Messages of safety are indicated with marks. The safety information contained in this manual is intended only for supplement of safety codes, insurance requirements, local laws, rules and regulations.
- (3) Messages of safety appear in the manual and on the machine: All messages of safety are identified by the words "DANGER", "WARNING" and "CAUTION".

- 1) **DANGER-** Indicates an imminently hazardous situation which, if not avoided, will result in death or serious injury and is represented as follows:

DANGER

- 2) **WARNING-** Indicates a potentially hazardous situation which, if not avoided, could result in death or serious injury and is represented as follows:

WARNING

- 3) **CAUTION-** Indicates a potentially hazardous situation which, if not avoided, may result in minor or moderate injury. It may also be used to alert against possible damage to the machine and its components and is represented as follows:

CAUTION

- (4) It is very difficult to forecast every danger that may occur during operation. However, safety can be guaranteed by fully understanding the operating procedures for this machine according to the methods recommended by the Manufacturer.
- (5) While operating the machine, be sure to perform work with great care, so as not to damage the machine, or allow accidents to occur.
- (6) Continue studying this manual until all Safety, Operation and Maintenance procedures are completely understood by all persons working with the machine.

<https://www.ebooklibonline.com>

Hello dear friend!

Thank you very much for reading.

Enter the link into your browser.

The full manual is available for immediate download.

<https://www.ebooklibonline.com>

SAFETY PRECAUTIONS

▲ WARNING

The proper and safe lubrication and maintenance for this machine, recommended by Manufacturer, are outlined in the OPERATOR'S MANUAL for the machine.

Improper performance of lubrication or maintenance procedures are dangerous and could result in injury or death. Read and understand the MANUAL before performing any lubrication or maintenance.

The serviceman or mechanic may be unfamiliar with many of the systems on this machine. This makes a careful use of the systems very important when performing maintenance operations. Sound knowledge of the system and or components is important before the removal or disassembly of any component.

Because of the size of some of the machine components, the serviceman or mechanic should check the weights noted in this manual. Use proper lifting procedures when removing any components. Weight of components table is shown in the section: TECHNICAL SPECIFICATIONS.

The following is a list of basic precautions that must always be observed.

- (1) Read and understand all Warning plates and decals on the machine before Operating, Maintaining or Repairing this machine.
- (2) Always wear protective glasses and protective shoes when working around machines. In particular, wear protective glasses when using hammers, punches or drifts on any part of the machine or attachments. Use welders gloves, hood/goggles, apron and the protective clothing appropriate to the welding job being performed. Do not wear loose fitting or torn clothing. Remove all rings from fingers, loose jewellery, confine long hair and loose clothing before working on this machinery.
- (3) Disconnect the battery and hang a "Maintenance in Progress" tag in the operator's seat. Remove starter key.
- (4) If possible, make all repairs with the machine parked on a level and firm surface. Block the machine so it does not roll while working on or under the machine. Hang a "Maintenance in Progress" tag in the operator's seat.

- (5) Do not work on any machine that is supported only by lift, jacks or a hoist. Always use blocks or stops for the jack before carrying out any disassembly operation.

▲ WARNING

Do not operate this machine unless you have read and understood all instructions contained in this manual. Improper machine operation is dangerous and could result in injury or death.

- (6) Relieve all pressure in air, oil or water systems before any lines, fittings or related items are disconnected or removed. Always make sure all raised components are blocked correctly and be alert for possible pressure when disconnecting any device from a system under pressure.
- (7) Lower the bucket, dozer or other attachments to the ground before performing any work on the machine. If this cannot be done, make sure the bucket, blade or other attachment is blocked correctly to prevent it from dropping unexpectedly.
- (8) Use steps and grab handles when mounting or dismounting a machine. Remove any debris or mud from steps, walkways or work platforms before using them. Always face the machine when using steps, ladders and walkways. When it is not possible to use the designed access system, provide ladders, scaffolds, or work, platforms to perform safe repair operations.
- (9) To avoid back injury, use a hoist when lifting components which weigh 20 kg or more. Make sure all chains, hooks, slings, etc., are in good condition and are the correct capacity. Be sure hooks are positioned correctly. Lifting eyes are not to be side loaded during a lifting operation.
- (10) To avoid burns, be alert for hot parts and surfaces immediately after stopping the machine such as hot fluids in lines, tubes and compartment covers.
- (11) Be careful when removing cover plates. Gradually back off the last two capscrews or nuts located at opposite ends of the cover or device and carefully pry the cover loose to relieve any spring or other pressure, before removing the last two capscrews or nuts completely.

SAFETY PRECAUTIONS

- (12) Be careful when removing filler caps, breathers and plugs on the machine. Hold a rag over the cap or plug to prevent being sprayed or splashed by liquids under pressure. Danger is even greater if the machine has just been stopped, as liquids might be boiling hot.
 - (13) Always use the proper tools that are in good condition and that are suited for the job at hand. Be sure you understand how to use them before performing any service work.
 - (14) Reinstall all clamps with the same spare part number. Do not use clamps of inferior quality if replacement is necessary.
 - (15) Repairs which require welding should be performed only with the benefit of the appropriate reference information and by personnel adequately trained and skilled in welding procedures. Determine the type of metal being welded and select the correct welding procedure and electrodes, rods or wires to provide a metal weld strength at least equivalent to that of the parent metal. Make sure to disconnect the battery before any welding operation is performed.
 - (16) Do not damage wiring during removal operations. Reinstall the wiring so it is not damaged nor will be damaged in operation of the machine by contacting sharp corners, or by rubbing against some object or hot surface. Do not connect wiring to a line containing fluid.
 - (17) Be sure all protective devices, including guards and shields, are properly installed and functioning correctly before starting a repair. If a guard or shield must be removed to perform the repair work, use extra caution and replace the guard or shield after repair is complete.
 - (18) Performing maintenance and repair operations while the bucket is lifted is dangerous, because there is the possibility of a device falling. Do not fail to lower such device and place the bucket to the ground before starting the operation.
 - (19) Loose or dirty fuel, lubrication and hydraulic systems, pipes and hoses may cause fires. Do not bend or strike high-pressure lines, do not install bent or damaged lines. Inspect lines, tubes and hoses carefully. Do not check for leaks with your hands. Very small (pinhole) leaks can result in a high velocity oil jet that will be invisible close to the hose.
- This oil can penetrate the skin and cause personal injury. Use card-board or paper to locate pinhole leaks.
- (20) Tighten connections to the correct torque. Make sure that all protections against burns, the clamps and the operator's protective devices are correctly installed in order to prevent excessive heat, vibrations or rubbing against other parts during operation. Shields that protect against oil spray onto hot exhaust components in event of a line, tube or seal failure must be installed correctly.
 - (21) Do not operate a machine if any rotating part is damaged or contacts any other part during operation. Any high speed rotating component that has been damaged or altered should be checked for balance before reusing.
 - (22) Be careful when servicing or separating the tracks. Chips can fly when removing or installing a track pin. Wear safety glasses and long sleeve protective clothing. Tracks can unroll very quickly when separated. Keep away from front and rear of machine. The machine can move unexpectedly when both tracks (crawlers) are disengaged from the sprockets. Block the machine to prevent it from moving.

TABLE OF CONTENTS

CX35B
CX39B

	Title	Table of Contents No.
SPECIFICATIONS	DESCRIPTION	1
	SPECIFICATIONS	2
	ATTACHMENT DIMENSIONS	3
MAINTENANCE	TOOLS	11
	MAINTENANCE STANDARDS AND TEST PROCEDURES	13
SYSTEMS	HYDRAULIC SYSTEM	22
	ELECTRICAL SYSTEM	23
	SYSTEMS COMPONENTS	24
DISASSEMBLY	GENERAL DISASSEMBLY AND ASSEMBLY	31
	ATTACHMENT	32
	SLEWING UPPER STRUCTURE	33
	TRAVEL SYSTEM	34
TROUBLESHOOTING	TROUBLESHOOTING (HYDRAULIC SYSTEM)	42
	TROUBLESHOOTING (ELECTRICAL SYSTEM)	43
	TROUBLESHOOTING (ENGINE)	44
E/G	ENGINE	51
OPT	AIR CONDITIONING SYSTEM	61
	OBJECT HANDLING SYSTEM	62
DATA	SUPPORTING DATA	71

1. DESCRIPTION

TABLE OF CONTENTS

1.1	GENERAL PRECAUTIONS FOR REPAIRS	1-1
1.1.1	PREPARATION BEFORE DISASSEMBLING	1-1
1.1.2	SAFETY IN DISASSEMBLING AND ASSEMBLING	1-1
1.1.3	DISASSEMBLING AND ASSEMBLING HYDRAULIC EQUIPMENT	1-1
1.1.4	ELECTRICAL EQUIPMENT	1-2
1.1.5	HYDRAULIC PARTS	1-3
1.1.6	WELDING REPAIR	1-3
1.1.7	ENVIRONMENTAL MEASURE	1-3
1.2	INTERNATIONAL UNIT CONVERSION SYSTEM (BASED ON MARKS' STANDARD HANDBOOK FOR MECHANICAL ENGINEERS)	1-4

1.1 GENERAL PRECAUTIONS FOR REPAIRS

1.1.1 PREPARATION BEFORE DISASSEMBLING



- (1) Understanding operating procedure
Read OPERATION AND MAINTENANCE MANUAL carefully to understand the operating procedure.
- (2) Cleaning machines
Remove soil, mud, and dust from the machine before carrying it into the service shop to prevent loss of work efficiency, damage of parts, and difficulty in rust prevention and dust protection while reassembling.
- (3) Inspecting machines
Identify the parts to be disassembled before starting work, determine the disassembling procedure by yourself considering the workshop situations etc., and request procurement of necessary parts in advance.
- (4) Recording
Record the following items for communication and prevention of recurring malfunction.
 - 1) Inspection date and place.
 - 2) Model name, applicable machine number, and hourmeter read.
 - 3) Trouble condition, place and cause.
 - 4) Visible oil leakage, water leakage and damage.
 - 5) Clogging of filters, oil level, oil quality, oil contamination and loosening of connections.
 - 6) Result of consideration if any problem exists based on the operation rate per month calculated from hourmeter indication after the last inspection date.
- (5) Arrangement and cleaning in service shop
 - 1) Tools required for repair work.
 - 2) Prepare space to place the disassembled parts.
 - 3) Prepare oil containers for draining oil etc.

1.1.2 SAFETY IN DISASSEMBLING AND ASSEMBLING



- (1) Wear appropriate clothes with long sleeves, safety shoes, safety helmet and protective glasses.

- (2) Suspend warning tag "DO NOT OPERATE" from the doorknob or the operating lever, and have a preliminary meeting before starting work.
- (3) Stop the engine before starting inspection and maintenance to prevent the operator being caught in machine.
- (4) Identify the location of a first-aid kit and a fire extinguisher, and also where to make contact in a state of emergency.
- (5) Choose a hard, level and safe place, and place the attachment on the ground securely.
- (6) Use a lifter such as a crane to remove heavy parts (20 kg or more) from the machine.
- (7) Use proper tools, and replace or repair defective tools.
- (8) Support the machine and attachment with supports or blocks if the work is performed in the lifted condition.

1.1.3 DISASSEMBLING AND ASSEMBLING HYDRAULIC EQUIPMENT



- (1) Removing hydraulic equipment
 - 1) Before disconnecting pipes, release the hydraulic pressure of the system, or open the return side cover and take out the filter.
 - 2) Carefully drain oil of the removed pipes into a containers without spilling on the floor.
 - 3) Apply plugs or caps on the pipe ends to avoid oil spillage and dust intrusion.
 - 4) Clean off the external surface of the equipment before disassembling, and drain hydraulic and gear oil before placing it on the workbench.
- (2) Disassembling hydraulic equipment
 - 1) Do not disassemble, reassemble or modify the hydraulic equipment without the permission of the manufacturer, who is not responsible for the performance and function of the product after modification.
 - 2) When disassembling and reassembling for unavoidable reason, refer the work to qualified personnel who have the specific knowledge or completed the parts service training.
 - 3) Provide matching marks to facilitate reassembling work.
 - 4) Before starting the work, read the manual of disassembling procedure, if it is provided, and decide whether the work can be performed by yourself.

1. DESCRIPTION

- 5) Use the special jig and tools without fail if they are specified.
 - 6) If it is hard to remove a part according to the procedure, do not try it by force but investigate the cause.
 - 7) Place the removed parts in order and attach tags to facilitate the reassembling.
 - 8) Note the location and quantity of parts commonly applied to multiple locations.
- (3) Inspecting parts
- 1) Ensure that the disassembled parts are free from seizure, interference and uneven contact.
 - 2) Measure and record wear condition of parts and clearance.
 - 3) If the problem is found in a part, repair or replace it with a new one.
- (4) Reassembling hydraulic equipment
- 1) Turn ON the ventilation fan or open windows to maintain good ventilation prior to starting the cleaning of parts.
 - 2) Perform rough and finish cleaning before assembling.
 - 3) Remove washing oil by air and apply clean hydraulic or gear oil for assembling.
 - 4) Always replace the removed O-rings, backup rings and oil seals with new ones by applying grease in advance.
 - 5) Remove dirt and moisture from and perform degreasing on the surface where liquid gasket to be applied.
 - 6) Remove rust preventive agent from the new parts before use.
 - 7) Fit bearings, bushings and oil seals using special jigs.
 - 8) Assemble the parts utilizing matching marks.
 - 9) Ensure all the parts are completely assembled after the work.
- (5) Installing hydraulic equipment
- 1) Ensure hydraulic oil and lubricant are properly supplied.
 - 2) Perform air bleeding when:
 1. Hydraulic oil changed
 2. Parts of suction side piping replaced
 3. Hydraulic pump installed
 4. Slewing motor installed
 5. Travel motor installed
 6. Hydraulic cylinder installed

⚠ WARNING

Operation of the hydraulic equipment without filling hydraulic oil or lubricant or without performing air bleeding will result in damage to the equipment.

- 3) Perform air bleeding of the hydraulic pump and slewing motor after loosening the upper drain plug, starting the engine and keep it in low idle condition.
Complete the air bleeding when seeping of hydraulic oil is recognized, and tightly plug.
- 4) Perform air bleeding of the travel motor and the hydraulic cylinders by running the engine for more than 5 minutes at low speed without load.

⚠ WARNING

Do not allow the hydraulic cylinder to bottom on the stroke end just after the maintenance.

- 5) Perform air bleeding of pilot line by performing a series of digging, slewing and travel.
- 6) Check hydraulic oil level after placing the attachment to the oil check position, and replenish oil if necessary.

1.1.4 ELECTRICAL EQUIPMENT

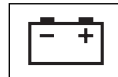

- (1) Do not disassemble electrical equipment.
- (2) Handle it carefully not to drop and give a shock.
- (3) Turn the key OFF prior to connecting and disconnecting work.
- (4) Disconnect the connector by holding it and pressing the lock. Do not pull the wire to apply force to the caulking portion.
- (5) Connect the connector and ensure it is completely locked.
- (6) Turn the key OFF prior to touching the terminal of starter or generator.
- (7) Remove the ground (earth) terminal of battery when handling tools around the battery or its relay.
- (8) Do not splash water on the electrical equipment and connectors during machine washing.
- (9) Check for moisture adhesion inside the waterproof connector after pulling it out, since it is hard to remove moisture from the connector.

If moisture adhesion is found, dry it completely before the connection.

▲ WARNING

Battery electrolyte is hazardous.

Battery electrolyte is dilute sulfuric acid. Exposure of skin or eyes to this liquid will cause burning or loss of eyesight.

If this occurs, take the following measures and get prompt specialised medical attention.

- **When skin exposed:**
Wash with water and soap sufficiently.
- **When eyes exposed:**
Immediately wash away with city water continuously for more than 10 minutes.
- **When a large amount of the liquid flows out:**
Neutralize with sodium bicarbonate or wash away with city water.
- **When swallowed:**
Drink a large amount of milk or water.
- **When clothes exposed:**
Immediately undress and wash.

1.1.5 HYDRAULIC PARTS



(1) O-ring

- Ensure O-rings have elasticity and are not damaged before use.
- Use the appropriate O-rings. O-rings are of different kinds and made of different materials, and they have a different hardness to be applied to a variety of parts, such as moving or fixed parts, subject to high pressure and exposed to corrosive fluids, even if their size is same.
- Fit the O-rings without distortion and bend.
- Always handle floating seals as a pair.

(2) Flexible hose (F hose)

- Use the appropriate parts. Different parts are used depending on the working pressure even the size of fitting and the total length of the hose is same.
- Tighten the fitting at the specified torque. Ensure no kink, tension, interference nor oil leakage is recognized.

1.1.6 WELDING REPAIR

- (1) Refer repair welding to qualified personnel according to the appropriate procedure.
- (2) Disconnect the ground (earth) cable of the battery before starting the repair.
Failure to do so will cause damage to the electrical equipment.
- (3) Move away the articles in advance that may cause fire if exposed to sparks.
- (4) Before starting the repair of the attachment, do not fail to cover the plated surface of the piston rod with flameproof sheet to prevent it from being exposed to sparks.

1.1.7 ENVIRONMENTAL MEASURE

- (1) Run the engine at the place that is sufficiently ventilated.
- (2) Industrial waste disposal
Dispose of the following parts according to the relevant regulations:
Waste oil and waste container
Battery
- (3) Precautions for handling hydraulic oil
Exposure of eyes to hydraulic oil will cause inflammation. Wear protective glasses before handling to avoid an accident. If an eye is exposed to the oil, take the following emergency measures:
 - When an eye exposed:
Immediately wash away with city water sufficiently till stimulative feeling vanishes.
 - When swallowed:
Do not let vomit, and receive medical treatment immediately.
 - When skin exposed:
Wash with water and soap sufficiently.
- (4) Others
Use replacement parts and lubricants authorized as the genuine parts.

1. DESCRIPTION

1.2 INTERNATIONAL UNIT CONVERSION SYSTEM (BASED ON MARKS' STANDARD HANDBOOK FOR MECHANICAL ENGINEERS)

Introduction

Although this manual includes International System of Unit and Foot-Pound System of Units, if you need SI unit, refer to the following international system of units. Given hereinafter is an except of the units that are related to this manual.

1. Etymology of SI Unites

French: Système International d'Unités

English: International System of Units

2. Construction of SI Unit System

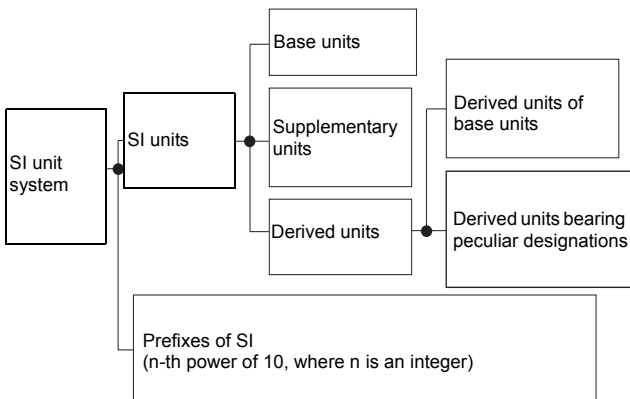

(1) Base units

Table 1-1

QUANTITIES	UNIT	MARK
Length	meter	m
Mass	Kilogram	kg
Time	second	s
Electric current	Ampère	A
Thermodynamic temperature	Kelvin	K
Amount of substance	mol	mol
Luminous intensity	candela	cd

(2) Supplementary units

Table 1-2

QUANTITIES	UNIT	MARK
Plane angle	radiant	rad
Solid angle	steradian	sr

(3) Derived Units

Table 1-3

QUANTITIES	UNIT	MARK
Area	square meter	m ²
Volume	cubic meter	m ³
Speed	metres per second	m/s
Acceleration	metres per square second	m/s ²
Density	kilogram per cubic meter	kg/m ³

(4) Derived units bearing peculiar designations

Table 1-4

QUANTITIES	UNIT	MARK	FORMULA
Frequency	Hertz	Hz	1/s
Force	Newton	N	kg • m/s ²
Pressure and stress	Pascal	Pa	N/m ²
Energy, Work and Quantity of heat	Joule	J	Nm
Power	Watt	W	J/s
Quantity of electricity	Coulomb	C	A•s
Potential difference, voltage and electromotive force	Volt	V	W/A
Quantity of static electricity and electric capacitance	Farad	F	C/V
Electric resistance	Ohm	Ω	V/A
Celsius temperature	Celsius degree or degree C		(t+273.15)K
Luminous intensity	lux	lx	lm/m ²

(5) Prefixes of SI

Table 1-5

PREFIX	MARK	MULTIPLICATION FACTORS
giga	G	10^9
mega	M	10^6
kilo	k	10^3
hecto	h	10^2
deca	da	10
deci	d	10^{-1}
centi	c	10^{-2}
milli	m	10^{-3}
micro	μ	10^{-6}
nano	n	10^{-9}
pico	p	10^{-12}

(6) Unit Conversion

Table 1-6

QUANTITIES	Gravitational	SI	CONVERSION FACTOR
Mass	kgf	kg	
Force	kgf	N	1 kgf = 9.807 N
Torque	kgf•m	Nm	kgf•m = 9.807 Nm
Pressure	kgf/cm ²	MPa	1 kgf/cm ² = 0.09807 MPa
Motive Power	PS	kW	1 PS = 0.7355 kW
Revolution	rpm	min ⁻¹	rpm

2. SPECIFICATIONS

TABLE OF CONTENTS

2.1	COMPONENTS NAME	2-1
2.2	MACHINE DIMENSIONS	2-2
2.3	SPECIFICATIONS AND PERFORMANCE	2-4
2.4	MACHINE AND COMPONENTS WEIGHT (DRY)	2-5
2.5	TRANSPORTATION	2-7
2.6	CRAWLER TYPE	2-9
2.7	TYPE OF BUCKET	2-9
2.8	ENGINE SPECIFICATIONS	2-11
2.8.1	SPECIFICATIONS	2-11
2.8.2	ENGINE PERFORMANCE CURVE	2-12
2.9	LUBRICANT, FUEL AND COOLANT SPECIFICATIONS	2-13

2.1 COMPONENTS NAME

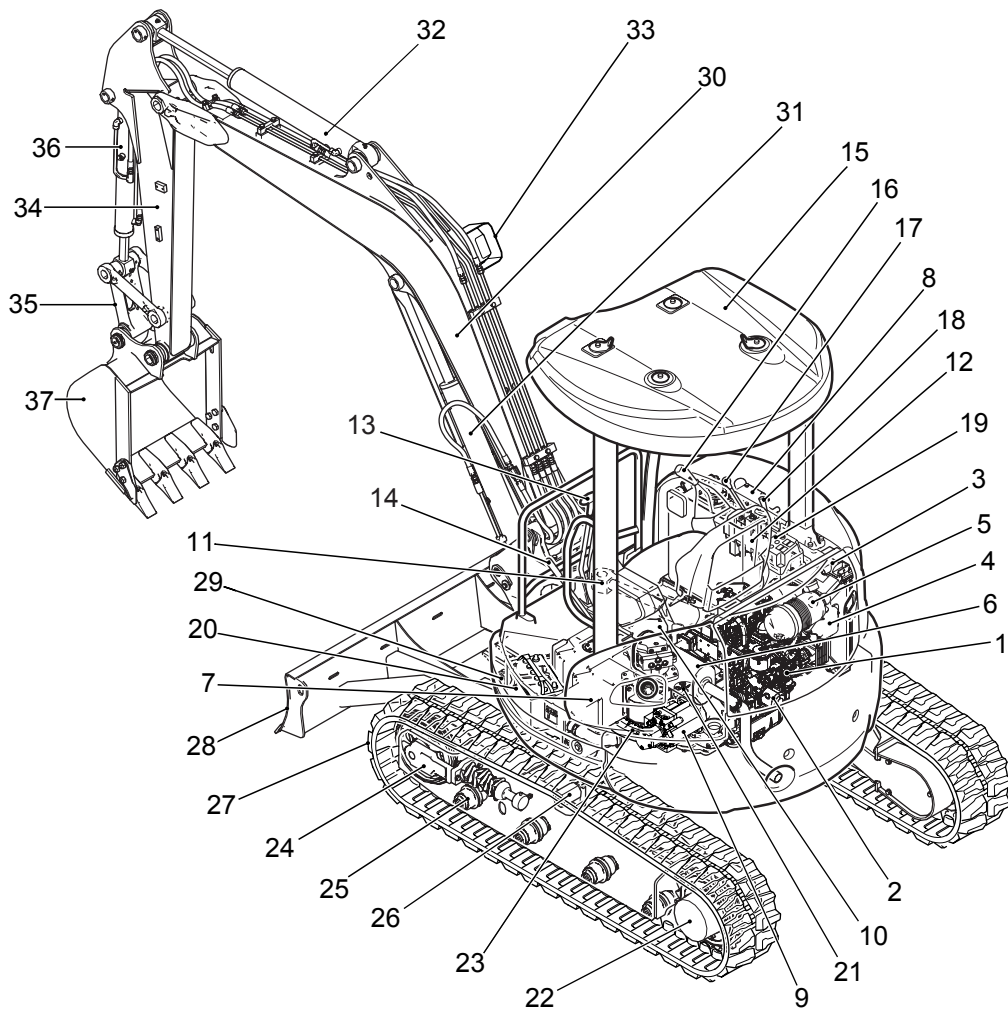

No.	NAME	No.	NAME	No.	NAME	No.	NAME
1	Engine	2	Oil screen	3	Radiator	4	Expansion tank
5	Air cleaner	6	Muffler	7	Fuel tank	8	Hydraulic oil tank
9	Hydraulic pump	10	Slewing motor	11	Swing cylinder	12	Control valve
13	Travel lever	14	Safety lever lock	15	Canopy	16	Operating lever
17	Dozer control lever	18	Throttle lever	19	Gauge cluster		
20	Battery	21	Rotary control valve	22	Travel motor	23	Slewing bearing
24	Idler adjust	25	Lower roller	26	Upper roller	27	Rubber belt
28	Dozer	29	Dozer cylinder	30	Boom	31	Boom cylinder
32	Arm cylinder	33	Lights	34	Arm	35	Link rod and idler link
36	Bucket cylinder	37	Bucket				

2. SPECIFICATIONS

2.2 MACHINE DIMENSIONS

Unit: mm

(1) CX35B (CANOPY)

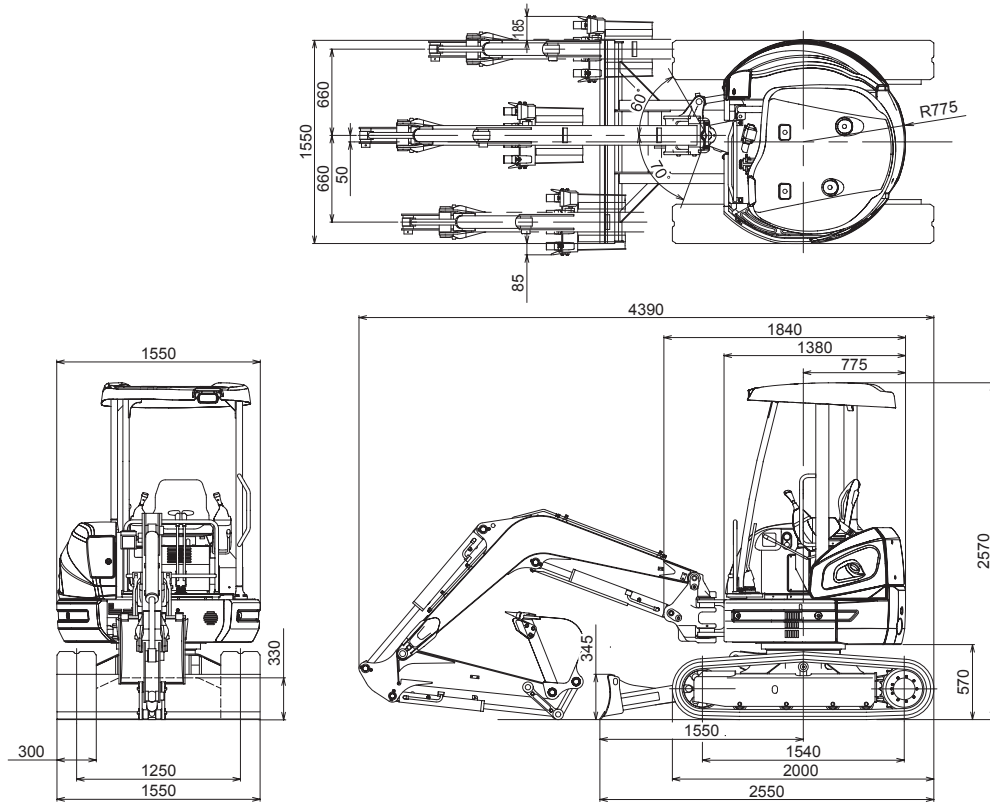

(2) CX35B (CAB)

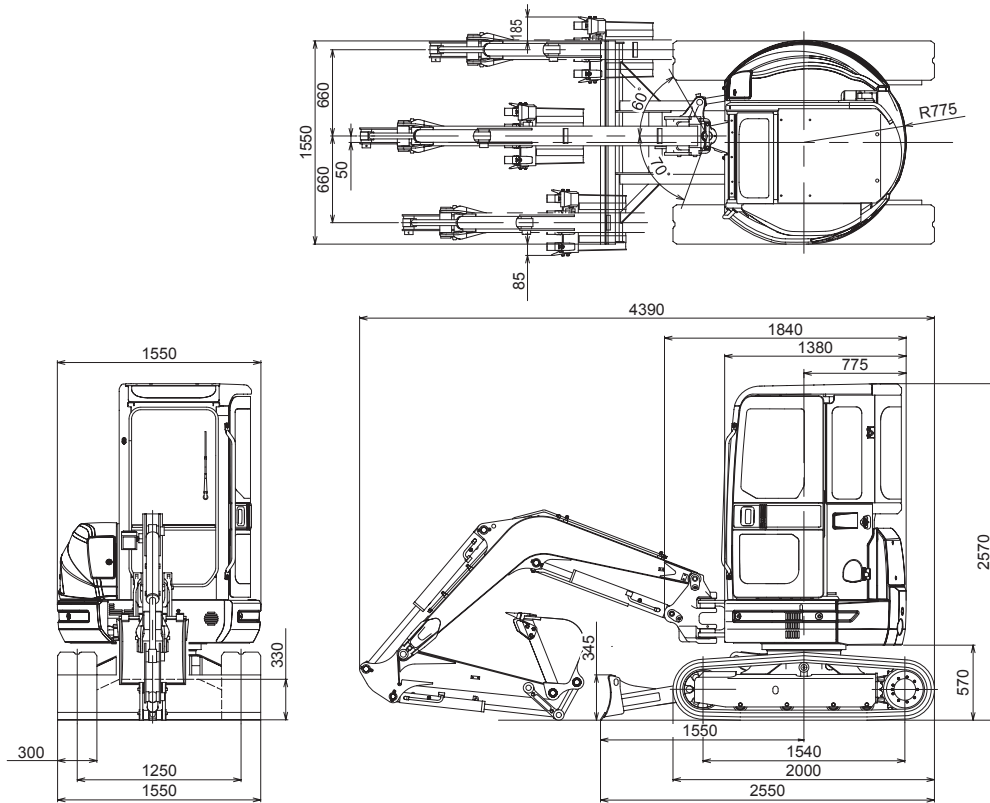

(3) CX39B (CANOPY)

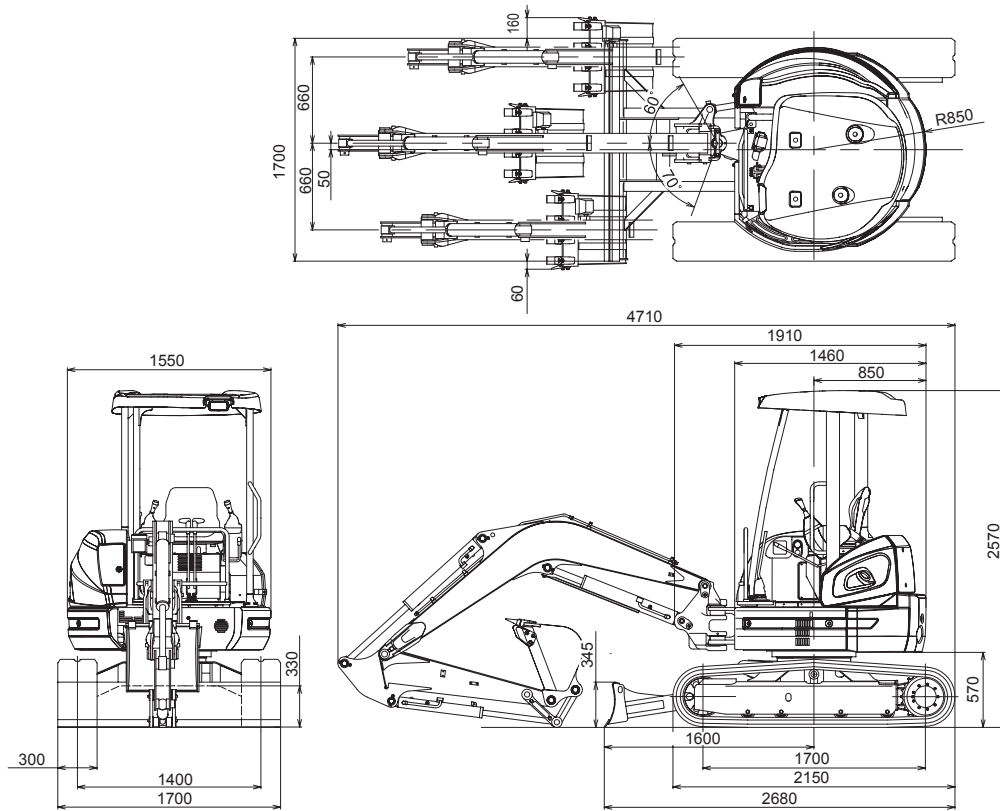

(4) CX39B (CAB)

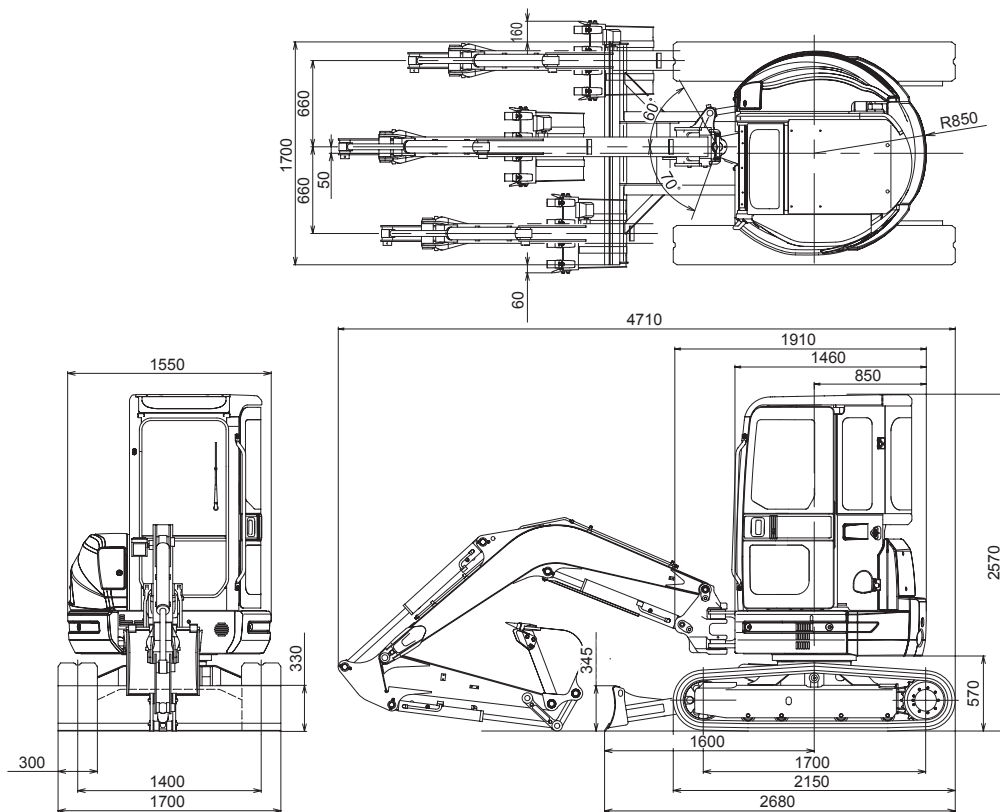

2. SPECIFICATIONS

2.3 SPECIFICATIONS AND PERFORMANCE

SPEED AND GRADEABILITY

Model	CX35B				CX39B				
Crawler type	Rubber belt		Steel crawler (OPT)		Rubber belt		Steel crawler (OPT)		
Rotation speed	rpm				8.9				
Travel speed	km/h	Low (1st)	High (2nd)	Low (1st)	High (2nd)	Low (1st)	High (2nd)	Low (1st)	High (2nd)
		2.5	4.5	2.5	4.5	2.5	4.5	2.5	4.5
Gradeability	% (degree)		58 (30°)						

ENGINE

Model (YANMAR)	3TNV88-PYB	
Type	Vertical. 4-cycle water-cooled diesel engine	
Number of cylinders-bore x stroke	3 - ø88 mm x 90 mm	
Total displacement	L	1.642
Rated output	kW / rpm	21.2 / 2400
Maximum torque	Nm / rpm	98.4 / 1440
Starter	V x kW	12 x 1.7
Generator	V x A	12 x 55

HYDRAULIC COMPONENTS

Hydraulic pump	Variable displacement axial piston + gear pump
Hydraulic motor	Axial piston
Hydraulic Motor w/Reduction gear (Travel)	2-axial pistons, 2-speed motor
Control valve	10-spools multiple control valve
Cylinder (boom, arm, swing, bucket, dozer)	Double action cylinder
Return filter	Safety valve containing/Filter type (30μ)

SWING AND DOZER

Type	Boom swing by hydraulic cylinder	
Boom swing angle	Right	60°
	Left	70°
Stroke of Dozer (above/below)	mm	560 / 410 540 / 440

WEIGHT

		CX35B		CX39B	
		Rubber belt	Steel crawler	Rubber belt	Steel crawler
Machine Weight	kg	3000	3110	3580	3700
Upper structure	kg	1650	←	1900	←
Travel system	kg	1050	1160	1140	1260
Equipment (boom + standard arm + standard bucket)	kg	370		460	
Oil and Water	kg	80		←	

Note: this figure is calculated with standard bucket.

2.4 MACHINE AND COMPONENTS WEIGHT (DRY)

Unit: kg

MODEL	CX35B			
	RUBBER TRACK		STEEL TRACK	
	CANOPY	CAB	CANOPY	CAB
COMPLETE MACHINE	3360	3500	3470	3610
SUPERSTRUCTURE ASSEMBLY	1650	1790	1650	1790
UPPER FRAME	375	←	←	←
CANOPY / CAB	85	220	85	220
ENGINE	155	←	←	←
HYDRAULIC PUMP	28	←	←	←
RADIATOR	3	←	←	←
HYDRAULIC TANK	42	←	←	←
FUEL TANK	4	←	←	←
SWING BRACKET	93	←	←	←
SWING CYLINDER	37	←	←	←
SWING MOTOR	38	←	←	←
CONTROL VALVE	25	←	←	←
COUNTERWEIGHT	370	←	←	←
GUARDS, BONNETS	92	←	←	←
BOOM CYLINDER	35	←	←	←
LOWER STRUCTURE ASSEMBLY	1050	←	1160	←
LOWER STRUCTURE	310	←	←	←
FITTINGS	42	←	←	←
TRAVEL MOTOR	42x2	←	←	←
LOWER ROLLER	6x8	←	←	←
IDLE WHEEL	27x2	←	←	←
IDLER ADJUSTER	14x2	←	←	←
SPROCKET	9x2	←	←	←
RUBBER TRACK	125x2	←	—	—
STEEL TRACK	—	—	180x2	←
ROTARY CONTROL VALVE	22	←	←	←
DOZER BLADE	140	←	←	←
DOZER BLADE CYLINDER	27	←	←	←
ATTACHMENT ASSEMBLY	370	←	←	←
BOOM ASSEMBLY	170	←	←	←
BOOM	120	←	←	←
ARM CYLINDER	30	←	←	←
ARM ASSEMBLY	120	←	←	←
ARM	70	←	←	←
BUCKET CYLINDER	20	←	←	←
BUCKET LINKS	10	←	←	←
IDLER LINK	4x2	←	←	←
BUCKET ASSEMBLY (STANDARD)	81	←	←	←
FLUIDS ASSEMBLY	80	←	←	←
HYDRAULIC OIL	42	←	←	←
FUEL	32	←	←	←
COOLANT	4	←	←	←

Note: bucket weight is shown with standard bucket weight.

2. SPECIFICATIONS

Unit: kg

MODEL	CX39B			
	RUBBER TRACK		STEEL TRACK	
	CANOPY	CAB	CANOPY	CAB
COMPLETE MACHINE	3760	3900	3870	4010
SUPERSTRUCTURE ASSEMBLY	1900	2040	1900	2040
UPPER FRAME	375	←	←	←
CANOPY / CAB	85	220	85	220
ENGINE	155	←	←	←
HYDRAULIC PUMP	28	←	←	←
RADIATOR	3	←	←	←
HYDRAULIC TANK	42	←	←	←
FUEL TANK	4	←	←	←
SWING BRACKET	93	←	←	←
SWING CYLINDER	37	←	←	←
SWING MOTOR	38	←	←	←
CONTROL VALVE	25	←	←	←
COUNTERWEIGHT	665	←	←	←
GUARDS, BONNETS	92	←	←	←
BOOM CYLINDER	35	←	←	←
LOWER STRUCTURE ASSEMBLY	1140	←	1260	←
LOWER STRUCTURE	370	←	←	←
FITTINGS	42	←	←	←
TRAVEL MOTOR	42x2	←	←	←
LOWER ROLLER	6x8	←	←	←
IDLE WHEEL	27x2	←	←	←
IDLER ADJUSTER	14x2	←	←	←
SPROCKET	9x2	←	←	←
RUBBER TRACK	134x2	←	—	—
STEEL TRACK	—	—	190x2	←
ROTARY CONTROL VALVE	22	←	←	←
DOZER BLADE	150	←	←	←
DOZER BLADE CYLINDER	27	←	←	←
ATTACHMENT ASSEMBLY	460	←	←	←
BOOM ASSEMBLY	190	←	←	←
BOOM	140	←	←	←
ARM CYLINDER	34	←	←	←
ARM ASSEMBLY	140	←	←	←
ARM	80	←	←	←
BUCKET CYLINDER	20	←	←	←
BUCKET LINKS	10	←	←	←
IDLER LINK	4x2	←	←	←
BUCKET ASSEMBLY (STANDARD)	89	←	←	←
FLUIDS ASSEMBLY	80	←	←	←
HYDRAULIC OIL	42	←	←	←
FUEL	32	←	←	←
COOLANT	4	←	←	←

Note: bucket weight is shown with standard bucket weight.

2.5 TRANSPORTATION

(1) LOADING MACHINE ON A TRAILER

- 1) Keep trailer bed clean. Put chocks against truck wheels.
- 2) Use a ramp or loading deck. Ramps must be strong enough, have a low angle, and correct height. Load and unload machine on a level surface.
- 3) Travel machine onto ramps slowly. Centre the machine over the trailer.
- 4) Lower all attachment.
- 5) Stop the engine. Remove the key from the starter switch.

▲ WARNING

Do not put chains over or against hydraulic lines or hoses.

- 6) Fasten machine to trailer with chains or cables.

During transportation, the bucket or attachments may hit the canopy or the cab. Therefore, set the machine in the transporting position by observing following points:

1. Extend the bucket cylinder fully.
2. Extend the arm cylinder fully.
3. Lower the boom.
4. If machine cannot be transported with dipper cylinder fully extended, remove bucket or attachment and extend dipper cylinder.

(2) TRANSPORTATION DIMENSION AND WEIGHT OF ATTACHMENT

1) BOOM WITH ARM CYLINDER

Model	CX35B	CX39B
L x H x W mm	2390 x 870 x 320	2590 x 810 x 320
Weight with arm cylinder (kg)	163	184

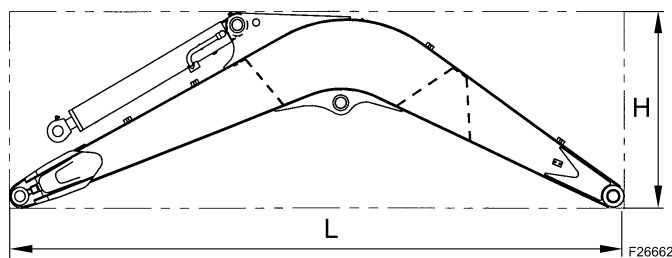

2) ARM AND BUCKET

Model	CX35B	CX39B
L x H x W mm	2190 x 450 x 500	2360 x 450 x 600
Weight kg	198	219

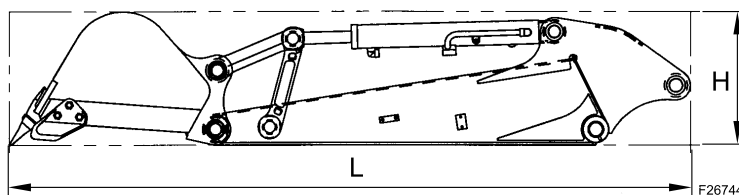

2. SPECIFICATIONS

3) EXCAVATOR ARM

Model	CX35B	CX39B
L x H x W mm	1520 x 430 x 280	1690 x 430 x 280
Weight kg	101	123

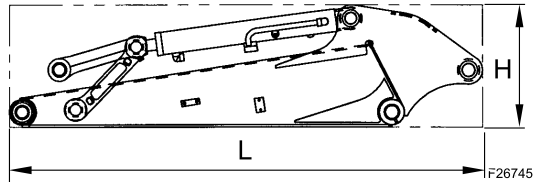

4) BUCKET

Model	CX35B	CX39B
Heaped Capacity m ³	0.09	0.11
L x H x W mm	670 x 620 x 500	670 x 620 x 600
Weight kg	72	78

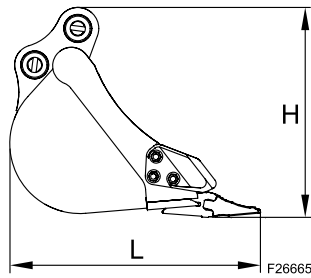

5) BLADE w/o cylinder weight

Model	CX35B	CX39B
L x H x W mm	1230 x 346 x 1550	1280 x 345 x 1700
Weight kg	142	150

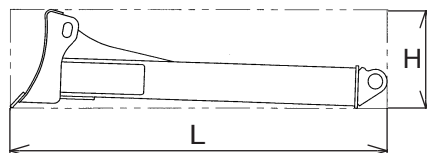

2.6 CRAWLER TYPE

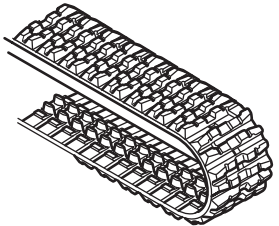
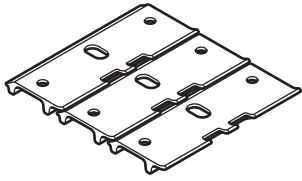
Type	Model	Crawler length mm	Total crawler width mm	Number of Link	Ground pressure kPa	
					CANOPY	CAB
Rubber belt 	CX35B	300	1550	82	29	30
	CX39B	300	1700	88	31	32
Steel track (optional) 	CX35B	300	1550	42	31	32
	CX39B	300	1700	45	32	33

2.7 TYPE OF BUCKET

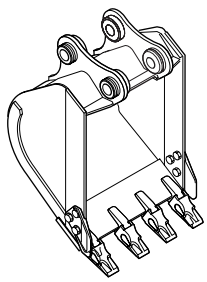
TYPE	ARM				
	Width mm	Heaped capacity m ³ (ISO 7451)	Weight kg	CX35B Length 1520 mm	CX39B Length 1690 mm
					
Bucket digging	350	0.050	66.77	▲ ●	▲ ●
Bucket digging	450	0.070	72.63	▲ ●	▲ ●
Bucket digging	500	0.090	75.74	▲ ●	▲ ●
Bucket digging	600	0.110	81.96	▲ ●	▲ ●
Bucket digging	700	0.120	89.70	▲ ●	▲ ●
Cleaning buckets	1000	0.160	69.04	■ ○ ◆	■ ○ ◆
Cleaning buckets	1200	0.176	77.44	■ ○ ◆	■ ○ ◆
Cleaning buckets	1400	0.196	85.85	■ ○ ◆	■ ○ ◆

2. SPECIFICATIONS

⚠ WARNING

- ◆ The buckets with this length, during left dipper slewing higher than 1 m from ground, can interfere with the cab. For a safe use, consult the Dealer and ask for left slewing limiter of the dipper support.
-

- : Width with lateral cutter

- : Width without lateral cutter

- ▲: Generic digging

for digging and sand loading operations, gravel, clay, earth in general, etc.

The specific weight of the material should not be higher than 1400 kg/m³

- : Bucket for digging and carrying sand, gravel, clay, earth in friable and dry state, ditch cleaning, etc.



Suggest:

If the above button click is invalid.

Please download this document

first, and then click the above link

to download the complete manual.

Thank you so much for reading

2.8 ENGINE SPECIFICATIONS

2.8.1 SPECIFICATIONS

Model	CX35B - CX39B		
Engine model	3TNV88-PYB		
Type	Vertical, 4-cycle water-cooled diesel engine		
Number of cylinders-bore x stroke	3 -88 mm x 90 mm		
Total displacement	1.642 litre		
Compression ratio	19,1		
Rated output	21.2 kW at 2400 rpm		
Maximum torque	99 ÷ 108 Nm at 1400 rpm		
Low idling	1250 ± 25 rpm		
High idling	2590 ± 25 rpm		
Fuel consumption rate	Less than 180 g / PS·h		
Allowable tilting angles	Continuous; 30° for all direction		
Rotation direction	Counterclockwise as viewed from flywheel side		
Order of ignition	1-3-2-1		
Injection time (injection time before top dead centre)	14 ± 1°		
Fuel injection pressure	200 ₀ ⁺¹⁰ kg / cm ²		
Valve action		Open	Close
	Intake valve	b.T.D.C. 15 ± 5°	a.B.D.C. 45 ± 5°
	Exhaust valve	b.T.D.C. 56 ± 5°	a.B.D.C. 18 ± 5°
Valve clearance	Intake valve	0.2 mm in cold condition	
	Exhaust valve	0.2 mm in cold condition	
Thermostat action	Start 71 ± 1.5 °C / Fully open 85 °C		
Compression pressure	3.43 ± 0.1 MPa at 250 rpm		
Lubrication oil pressure	0.44 MPa at 2300 rpm		
Dimensions L x H x W	585 x 521 x 648 mm		
Dry weight	155 kg		
Injection governor	Mechanical centrifugal governor (All speed type)		
Fuel filter	Paper-element cartridge		
Lubrication system	Forced lubrication with trochoid pump		
Cooling system	Coolant / radiator		
Starter capacity	12 V x 1.7 kW		
Generator capacity	12 V x 50 A		
Starting aid	Air heater (12 V - 400 W)		
Cooling water capacity: max / engine	4.0 / 2.0 litres		
Engine oil volume: max / effective	6.7 / 2.8 litres		

<https://www.ebooklibonline.com>

Hello dear friend!

Thank you very much for reading.

Enter the link into your browser.

The full manual is available for immediate download.

<https://www.ebooklibonline.com>