



**Bobcat®**

# Service Manual

**S/N 528711001 & Above  
S/N 528811001 & Above  
S/N 538711001 & Above  
S/N 538811001 & Above**

**Mini Track Loader**

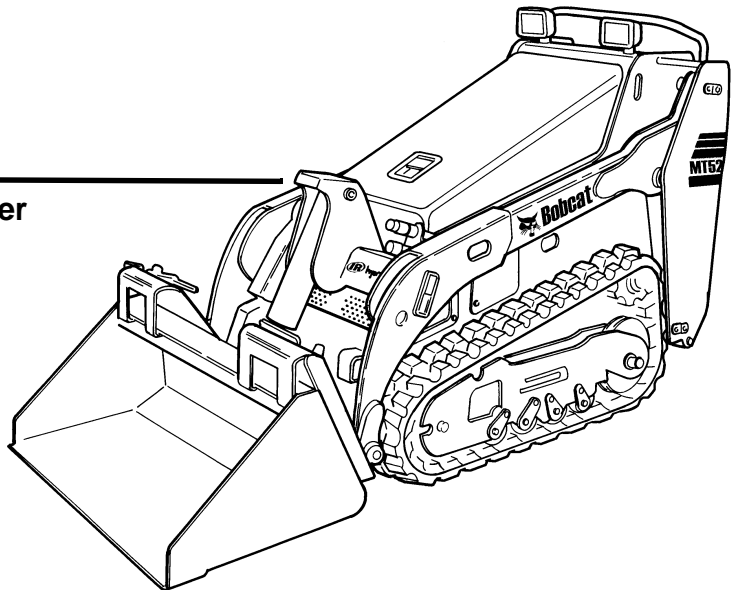

# MAINTENANCE SAFETY



## WARNING

Instructions are necessary before operating or servicing machine. Read and understand the Operation & Maintenance Manual, Operator's Handbook and signs (decals) on machine. Follow warnings and instructions in the manuals when making repairs, adjustments or servicing. Check for correct function after adjustments, repairs or service. Untrained operators and failure to follow instructions can cause injury or death.

W-2003-0903

### CORRECT

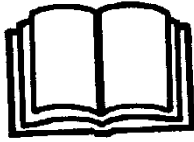

B-10731a

- ⚠ Never service the Bobcat Mini Track Loader without instructions.



**Safety Alert Symbol:** This symbol with a warning statement, means: "Warning, be alert! Your safety is involved!" Carefully read the message that follows.

### WRONG



B-23041

- ⚠ Have good ventilation when welding or grinding painted parts.
- ⚠ Wear dust mask when grinding painted parts. Toxic dust and gas can be produced.
- ⚠ Avoid exhaust fume leaks which can kill without warning. Exhaust system must be tightly sealed.

### WRONG

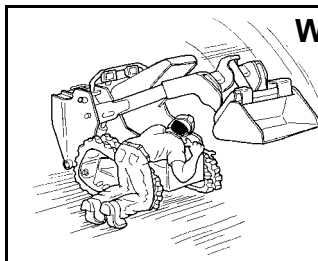

B-23035

- ⚠ Disconnecting or loosening any hydraulic tubeline, hose, fitting, component or a part failure can cause lift arms to drop. Do not go under lift arms when raised unless supported by an approved lift arm support device. Replace it if damaged.

### WRONG

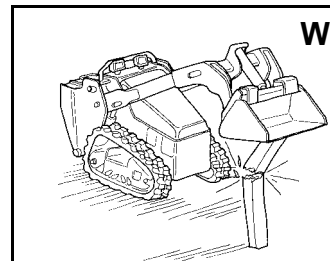

B-23036

- ⚠ Never work on loader with lift arms up unless lift arms are held by an approved lift arm support device. Replace if damaged.
- ⚠ Never modify equipment or add attachments not approved by Bobcat Company.

### WRONG

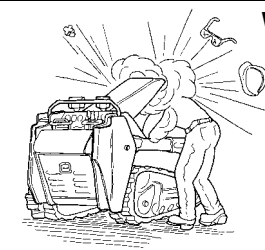

B-23039

- ⚠ Stop, cool and clean engine of flammable materials before checking fluids.
- ⚠ Never service or adjust loader with the engine running unless instructed to do so in the manual.
- ⚠ Avoid contact with leaking hydraulic fluid or diesel fuel under pressure. It can penetrate the skin or eyes.
- ⚠ Never fill fuel tank with engine running, while smoking or when near open flame.

### WRONG

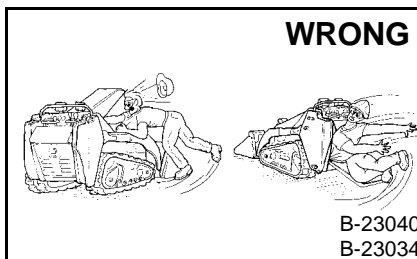

B-23040  
B-23034

- ⚠ Keep body, jewelry and clothing away from moving parts, electrical contact, hot parts and exhaust.
- ⚠ Wear eye protection to guard from battery acid, compressed springs, fluids under pressure and flying debris when engines are running or tools are used. Use eye protection approved for type of welding.
- ⚠ Keep rear door closed except for service. Close and latch door before operating the loader.

### WRONG



B-6589

- ⚠ Lead-acid batteries produce flammable and explosive gases.
- ⚠ Keep arcs, sparks, flames and lighted tobacco away from batteries.
- ⚠ Batteries contain acid which burns eyes or skin on contact. Wear protective clothing. If acid contacts body, flush well with water. For eye contact flush well and get immediate medical attention.

Maintenance procedures which are given in the Operation & Maintenance Manual can be performed by the owner/operator without any specific technical training. Maintenance procedures which are **not** in the Operation & Maintenance Manual must be performed **ONLY BY QUALIFIED BOBCAT SERVICE PERSONNEL**. Always use genuine Bobcat replacement parts. The Service Safety Training Course is available from your Bobcat dealer.

## ALPHABETICAL INDEX

AIR CLEANER .....	70-01	HYDROSTATIC CONTROLS	
AIR CLEANER SERVICE .....	10-01	(S/N 528712700 & ABOVE,	
ALTERNATOR .....	60-01	S/N 528811150 & ABOVE,	
		S/N 538712500 & ABOVE) .....	30-01
BATTERY .....	60-01	HYDROSTATIC PUMP .....	30-01
BOB-TACH.....	10-01, 50-01	HYDROSTATIC SYSTEM INFORMATION.....	30-01
BOTTOM ACCESS PANEL .....	50-01		
		INSTRUMENT PANEL.....	50-01
CONTROLS .....	10-01	LOADER SPECIFICATIONS .....	SPEC-01
CONVERSIONS .....	SPEC-01	LIFT ARM .....	50-01
CYLINDER (LIFT) .....	20-01	LIFT ARM SUPPORT DEVICE.....	10-01
CYLINDER (TILT) .....	20-01	LIFTING AND BLOCKING THE LOADER.....	10-01
		LUBRICATION OF THE BOBCAT LOADER .....	10-01
DRIVE BELT .....	30-01		
DRIVE COMPONENTS .....	40-01	MAIN RELIEF VALVE .....	20-01
DRIVE MOTOR.....	30-01	MUFFLER.....	70-01
ELECTRICAL ATTACHMENT CONTROL REF. ....	60-01	NEUTRAL START SENSOR	
ELECTRICAL SYSTEM .....	10-01	(S/N 528711001-528712429,	
ELECTRICAL SYSTEM INFORMATION .....	60-01	S/N 528811001-528811121,	
ENGINE (S/N 528711001-528712699,		S/N 538711001-528712295) .....	60-01
S/N 528811001-528811149,		NEUTRAL START SENSOR	
S/N 538711001-528712499) .....	70-01	(S/N 528712430 & ABOVE,	
ENGINE (S/N 528712700 & ABOVE,		S/N 528811122 & ABOVE,	
S/N 528811150 & ABOVE,		S/N 538712296 & ABOVE) .....	60-01
S/N 538712500 & ABOVE) .....	70-01		
ENGINE COMPONENTS AND TESTING .....	70-01	PARKING BRAKE.....	40-01
ENGINE COOLING SYSTEM.....	10-01	PORT RELIEF VALVES.....	20-01
ENGINE INFORMATION AND TESTING .....	70-01		
ENGINE LUBRICATION SYSTEM.....	10-01	RADIATOR .....	70-01
ENGINE SPECIFICATIONS.....	SPEC-01	RECONDITIONING THE ENGINE .....	70-01
ENGINE SPEED CONTROL .....	70-01	REVERSE STOP PANEL .....	50-01
		RIDE-ON PLATFORM .....	50-01
FLYWHEEL.....	70-01		
FUEL SYSTEM .....	10-01	SERVICE SCHEDULE .....	10-01
FUEL TANK.....	50-01	SPARK ARRESTOR MUFFLER.....	10-01
		STARTER .....	60-01
GRAB BAR .....	50-01		
		TAILGATE.....	50-01
HOOD .....	50-01	TORQUE SPECIFICATIONS FOR BOLTS .....	SPEC-01
HYDRAULIC CONNECTION SPECS.....	SPEC-01	TOWING THE LOADER .....	10-01
HYDRAULIC CONTROL VALVE .....	20-01	TRANSPORTING THE BOBCAT LOADER.....	10-01
HYDRAULIC FILTER .....	20-01		
HYDRAULIC FLUID RESERVOIR.....	20-01		
HYDRAULIC FLUID SPECIFICATIONS .....	SPEC-01		
HYDRAULIC OIL COOLER .....	20-01		
HYD. GEAR PUMP MOUNTING BRACKET .....	70-01		
HYDRAULIC PUMP.....	20-01		
HYDRAULIC/HYDROSTATIC SYSTEM .....	10-01		
HYDRAULIC SYSTEM INFORMATION.....	20-01		
HYDROSTATIC CONTROLS			
(S/N 528711001-528712699,			
S/N 528811001-528811149,			
S/N 538711001-528712499) .....	30-01		

**<https://www.ebooklibonline.com>**

Hello dear friend!

Thank you very much for reading.

Enter the link into your browser.

The full manual is available for immediate download.

**<https://www.ebooklibonline.com>**

# CONTENTS

FOREWORD.....	III
SAFETY INSTRUCTIONS .....	V
SERIAL NUMBER LOCATION .....	IX
DELIVERY REPORT.....	IX
BOBCAT LOADER IDENTIFICATION.....	X
SAFETY AND MAINTENANCE.....	10-01
HYDRAULIC SYSTEM .....	20-01
HYDROSTATIC SYSTEM.....	30-01
DRIVE SYSTEM .....	40-01
MAIN FRAME .....	50-01
ELECTRICAL SYSTEM & ANALYSIS.....	60-01
ENGINE SERVICE .....	70-01
SPECIFICATIONS.....	SPEC-01

**SAFETY &  
MAINTENANCE**

**HYDRAULIC  
SYSTEM**

**HYDROSTATIC  
SYSTEM**

**DRIVE  
SYSTEM**

**MAIN FRAME**

**ELECTRICAL  
SYSTEM &  
ANALYSIS**







**ENGINE  
SERVICE**

**SPECIFICATIONS**

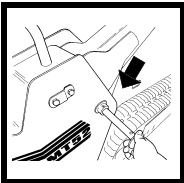
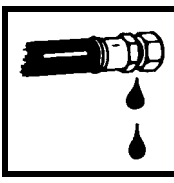
# FOREWORD

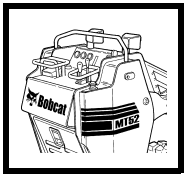
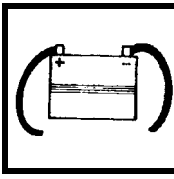
This manual is for the Bobcat loader mechanic. It provides necessary servicing and adjustment procedures for the Bobcat Mini loader and its component parts and systems. Refer to the Operation & Maintenance manual for operating instructions, Starting procedure, daily checks, etc.

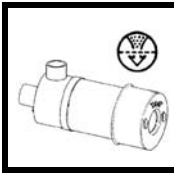
A general inspection of the following items must be made after the loader has had service or repair:

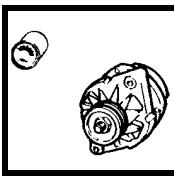
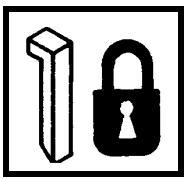
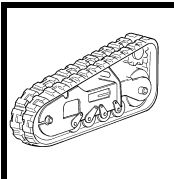
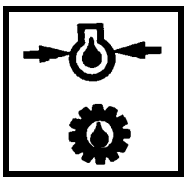
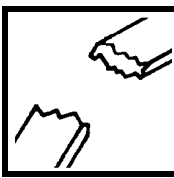
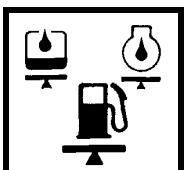
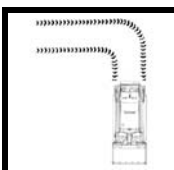
- |                                                                                   |                                                                                     |                                                                                      |                                                                                       |
|-----------------------------------------------------------------------------------|-------------------------------------------------------------------------------------|--------------------------------------------------------------------------------------|---------------------------------------------------------------------------------------|
| 1. Check lift arm support device, replace if damaged. (Stored Position)           |    | 9. Inspect for fuel, oil or hydraulic fluid leaks.                                   |    |
| 2. Machine signs must be legible and in the correct location.                     |    | 10. Lubricate the loader.                                                            |    |
| 3. Controls must return to neutral.                                               |    | 11. Check the condition of the battery and cables.                                   |    |
| 4. (Optional) Check for correct function of the work lights                       |   | 12. Inspect the air cleaner for damage or leaks. Check the condition of the element. |   |
| 5. The parking brake must function correctly.                                     |  | 13. Check the electrical charging system.                                            |  |
| 6. Bob-Tach wedges and linkages must function correctly and be in good condition. |  | 14. Check tracks for wear and pressure.                                              |  |
| 7. Check for correct function of indicator lamps (Optional on some models).       |  | 15. Inspect for loose or broken parts or connections.                                |  |
| 8. Check hydraulic fluid level, engine oil level and fuel supply.                 |  | 16. Operate the loader and check all functions.                                      |  |

17. Check for any field modification not completed.

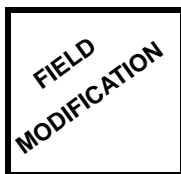

18. Check for correct function of lift/tilt lockouts, neutral start interlocks and reverse stop panel.

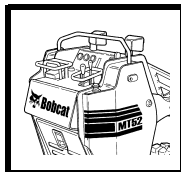

Recommend to the owner that all necessary corrections be made before the machine is returned to service.

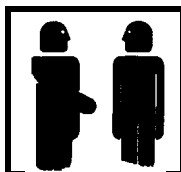

**CALIFORNIA  
PROPOSITION 65 WARNING**

Diesel engine exhaust and some of its constituents are known to the State of California to cause cancer, birth defects and other reproductive harm.

## SAFETY INSTRUCTIONS



### Safety Alert Symbol

This symbol with a warning statement means:  
“Warning, be alert! Your safety is involved!”  
Carefully read the message that follows.



## WARNING

Instructions are necessary before operating or servicing machine. Read and understand the Operation & Maintenance Manual and signs (decals) on machine. Follow warnings and instructions in the manuals when making repairs, adjustments or servicing. Check for correct function after adjustments, repairs or service. Untrained operators and failure to follow instructions can cause injury or death.

W-2411-1001



## WARNING

Warnings on the machine and in the manuals are for your safety. Failure to obey warnings can cause injury or death.

W-2044-1285

## IMPORTANT

This notice identifies procedures which must be followed to avoid damage to the machine.

I-2019-0284

The following publications provide information on the safe use and maintenance of the Bobcat machine and attachments:

- The Delivery Report is used to assure that complete instructions have been given to the new owner and that the machine is in safe operating condition.
- The Operation & Maintenance Manual delivered with the machine or attachment contains operating information as well as routine maintenance and service procedures. It is a part of the machine and can be stored in a container provided on the machine. Replacement Operation & Maintenance Manuals can be ordered from your Bobcat dealer.
- Machine signs (decals) instruct on the safe operation and care of your Bobcat machine or attachment. The signs and their locations are shown in the Operation & Maintenance Manual. Replacement signs are available from your Bobcat dealer.
- The Service Manual and Parts Manual are available from your dealer for use by mechanics to do shop-type service and repair work.
- The Mini Loader Safety Video is available from your Bobcat dealer or at [www.training.bobcat.com](http://www.training.bobcat.com) or [www.bobcat.com](http://www.bobcat.com).

SI ML-0206 SM

## SAFETY INSTRUCTIONS (CONT'D)

The dealer and owner/operator review the recommended uses of the product when delivered. If the owner/operator will be using the machine for a different application(s) he or she must ask the dealer for recommendations on the new use.



# Call Before You Dig

**1-888-258-0808**

When you call, you will be directed to a location in your state/city for information about buried lines (telephone, cable TV, water, sewer, gas, etc.)

## SAFETY INSTRUCTIONS (CONT'D)

### Fire Prevention

The machine and attachments have components that are at high temperature under normal operating conditions. The primary source of high temperatures is the engine and exhaust system. The electrical system, if damaged or incorrectly maintained, can be a source of arcs or sparks.

Flammable debris (leaves, straw, etc.) must be removed regularly. If flammable debris is allowed to accumulate, it will increase fire hazard. Clean often to avoid this accumulation. Flammable debris in the engine compartment is a potential hazard.

The spark arrestor muffler is designed to control the emission of hot particles from the engine and exhaust system, but the muffler and the exhaust gases are still hot.

- Do not use the machine where exhaust, arcs, sparks or hot components can contact flammable material, explosive dust or gases.
- The operator cab, engine compartment, and engine cooling system must be inspected every day and cleaned if necessary to prevent fire hazard and overheating.
- Check all electrical wiring and connections for damage. Keep the battery terminals clean and tight. Repair or replace any damaged part.
- Check fuel and hydraulic tubes, hoses and fittings for damage and leakage. Never use open flame or bare skin to check for leaks. Tighten or replace any parts that show leakage. Always clean fluid spills. Do not use gasoline or diesel fuel for cleaning parts. Use commercial nonflammable solvents.
- Do not use ether or starting fluids on any engine which has glow plugs. These starting aids can cause explosion and injure you or bystanders.
- Always clean the machine, disconnect the battery, and disconnect the wiring from the controllers before welding. Cover rubber hoses, battery and all other flammable parts. Keep a fire extinguisher near the machine when welding. Have good ventilation when grinding or welding painted parts. Wear a dust mask when grinding painted parts. Toxic dust or gas can be produced.
- Stop the engine and let it cool before adding fuel. **NO SMOKING!**

- Use the procedure in the Operation & Maintenance Manual for connecting the battery and for jump starting.
- Use the procedure in the Operation & Maintenance Manual for cleaning the spark arrestor muffler (if equipped).

Figure 1

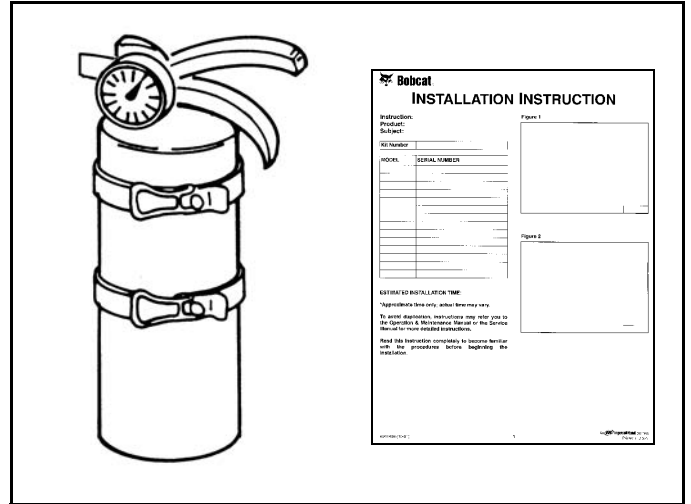

- Know where fire extinguishers and first aid kits are located and how to use them. Fire extinguishers are available from your Bobcat dealer [Figure 1].

## SERIAL NUMBER LOCATION

Always use the serial number of the loader when requesting service information or when ordering parts. Early or later models (identification made by serial number) may use different parts, or it may be necessary to use a different procedure in doing a specific service operation.

### Loader Serial Number

Figure 1

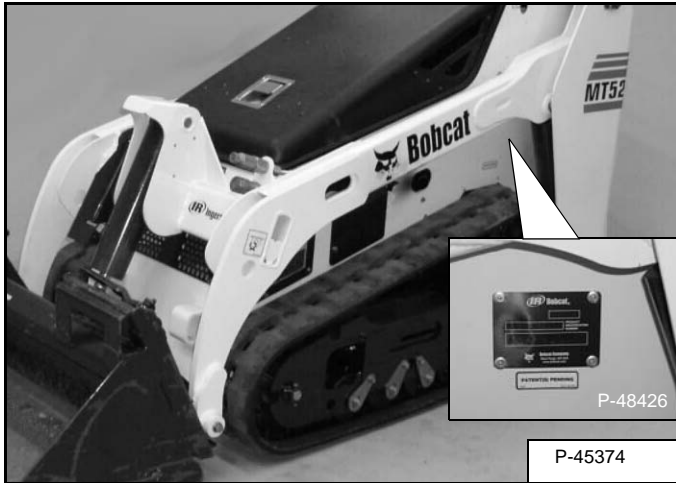

The loader serial number plate is located on the loader frame as shown [Figure 1].

Explanation of loader Serial Number:

XXXX	XXXXX
Model 1.-Model/ Engine Combination	Model 2.-Production Sequence (Series)

1. The four digit Model/Engine Combination Module number identifies the model number and engine combination.
2. The five digit Production Sequence Number identifies the order which the loader is produced.

### Engine Serial Number

Figure 2

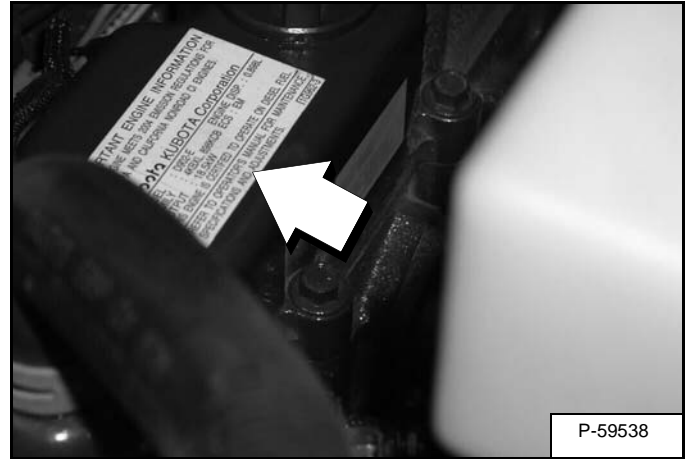

The engine serial number is in the location shown [Figure 2].

### DELIVERY REPORT

Figure 3

The Delivery Report must be filled out by the dealer and signed by the owner or operator when the Bobcat loader is delivered. An explanation of the form must be given to the owner. Make sure it is filled out completely [Figure 3].

# BOBCAT LOADER IDENTIFICATION

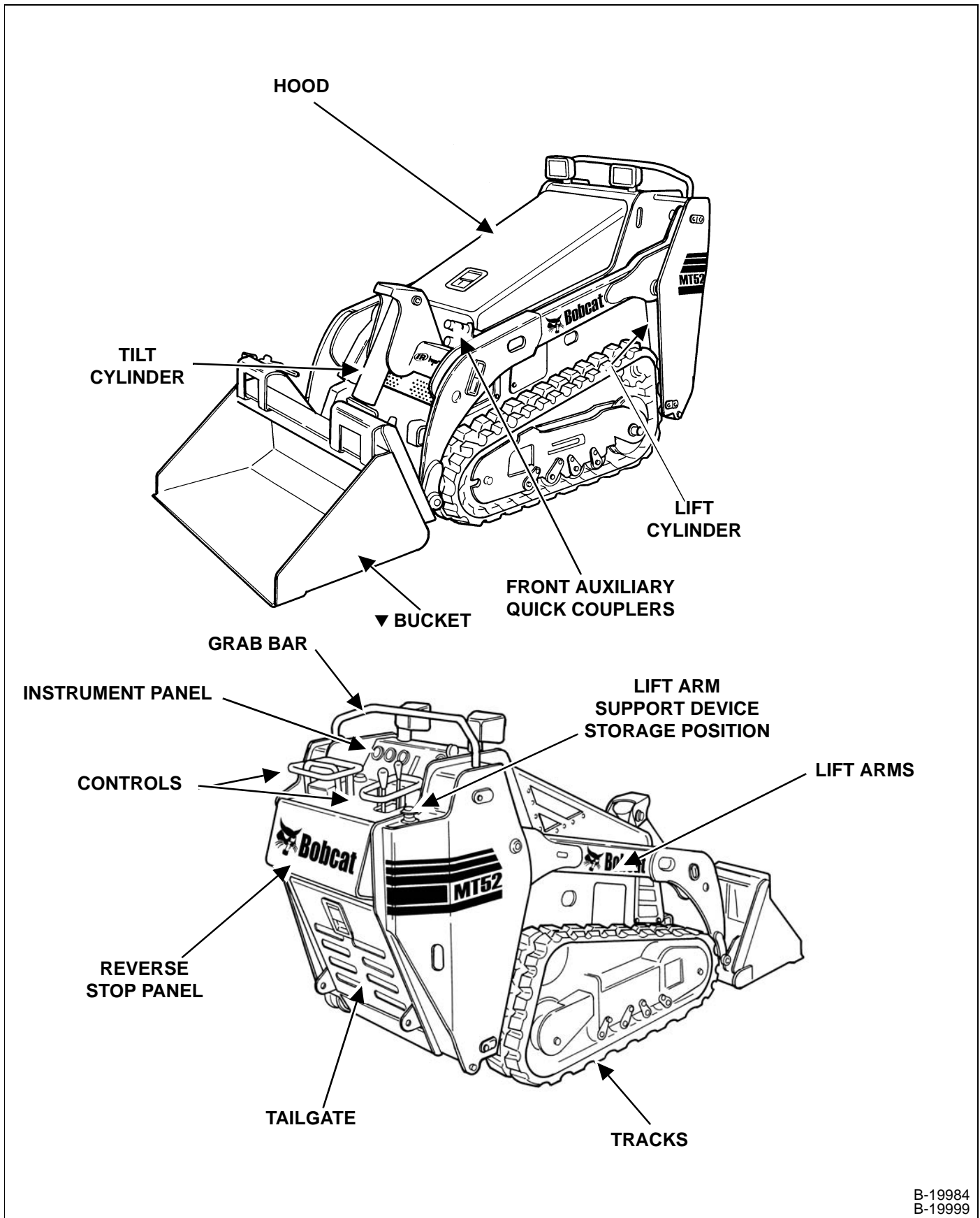

B-19984  
B-19999

▼ BUCKET - A bucket and other attachments are available for the Bobcat Mini Loader.

## SAFETY AND MAINTENANCE

## SAFETY & MAINTENANCE

AIR CLEANER SERVICE . . . . .	10-60-1
Replacing The Filter Elements (Early Models) . . . . .	10-60-1
Replacing The Filter Elements (Later Models) . . . . .	10-60-2
BOB-TACH . . . . .	10-110-1
Inspection And Maintenance . . . . .	10-110-1
CONTROLS . . . . .	10-140-1
Lift Arm By-Pass Controls . . . . .	10-140-1
Lift And Tilt Function Lockouts . . . . .	10-140-1
Neutral Start Interlocks . . . . .	10-140-2
Reverse Stop Panel . . . . .	10-140-1
ELECTRICAL SYSTEM . . . . .	10-150-1
Cleaning Battery Terminals . . . . .	10-150-2
Description . . . . .	10-150-1
Fuse And Relay Location / Identification . . . . .	10-150-1
Removing And Installing The Battery . . . . .	10-150-4
Using A Booster Battery (Jump Starting) . . . . .	10-150-3
ENGINE COOLING SYSTEM . . . . .	10-70-1
Checking The Coolant Level . . . . .	10-70-1
Cleaning The Cooling System . . . . .	10-70-2
Replacing The Coolant . . . . .	10-70-2
ENGINE LUBRICATION SYSTEM . . . . .	10-90-1
Checking Engine Oil . . . . .	10-90-1
Oil Chart . . . . .	10-90-1
Replacing Oil And Filter . . . . .	10-90-1
FUEL SYSTEM . . . . .	10-80-1
Filling The Fuel Tank . . . . .	10-80-1
Fuel Filter . . . . .	10-80-2
Fuel Specifications . . . . .	10-80-1
Removing Air From The Fuel System . . . . .	10-80-2
HYDRAULIC / HYDROSTATIC SYSTEM . . . . .	10-100-1
Checking And Adding Fluid . . . . .	10-100-1
Hydraulic Reservoir Breather . . . . .	10-100-1
Replacing Hydraulic Filter . . . . .	10-100-1
Replacing Hydraulic Fluid . . . . .	10-100-2

**Continued On Next Page**

## SAFETY AND MAINTENANCE (CONT'D)

LIFT ARM SUPPORT DEVICE .....	10-20-1
Installing .....	10-20-1
Removing .....	10-20-1
LIFTING AND BLOCKING THE LOADER .....	10-10-1
Four Point Lift .....	10-10-2
Procedure .....	10-10-1
LUBRICATION OF THE BOBCAT MINI LOADER .....	10-120-1
Parking Brake Lubrication .....	10-120-2
Pivot Pins .....	10-120-3
Procedure .....	10-120-1
SERVICE SCHEDULE .....	10-50-1
Chart .....	10-50-1
SPARK ARRESTOR MUFFLER .....	10-130-1
Servicing .....	10-130-1
TOWING THE LOADER .....	10-40-1
Procedure .....	10-40-1
TRANSPORTING THE BOBCAT LOADER .....	10-30-1
Procedure .....	10-30-1

**TIGHTEN ALL HARDWARE PER SIZE TO GRADE 5 TORQUE (SEE STANDARD TORQUE SPECIFICATIONS FOR BOLTS, SECTION SPEC-01) UNLESS OTHERWISE SPECIFIED.**

## LIFTING AND BLOCKING THE LOADER

### Procedure

# WARNING

Instructions are necessary before operating or servicing machine. Read and understand the Operation & Maintenance Manual and signs (decals) on machine. Follow warnings and instructions in the manuals when making repairs, adjustments or servicing. Check for correct function after adjustments, repairs or service. Untrained operators and failure to follow instructions can cause injury or death.

W-2408-0801

Figure 10-10-1

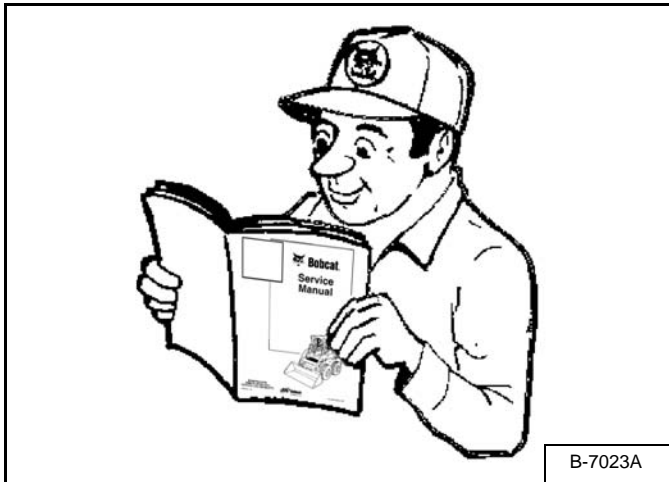

Read the Removal & Installation, Disassembly & Assembly, etc. completely to become familiar with the procedure before beginning [Figure 10-10-1].

Always park the loader on a level surface.

# WARNING

When the engine is running during service, the steering control lever and hydraulic control levers must be in NEUTRAL and the parking brake engaged.

W-2488-1203

Figure 10-10-2

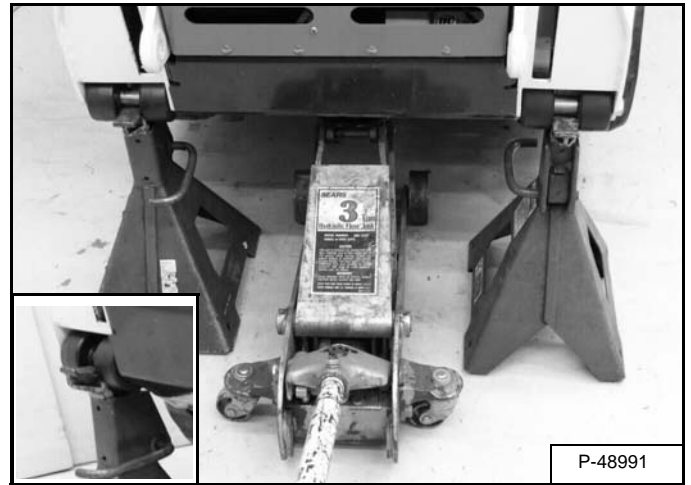

Raise the rear of the machine [Figure 10-10-2] and put jackstands under the rear roller wheels (Inset) [Figure 10-10-2]. Be sure the jackstands do not touch the tracks. Lower the machine to the jackstands.

Figure 10-10-3

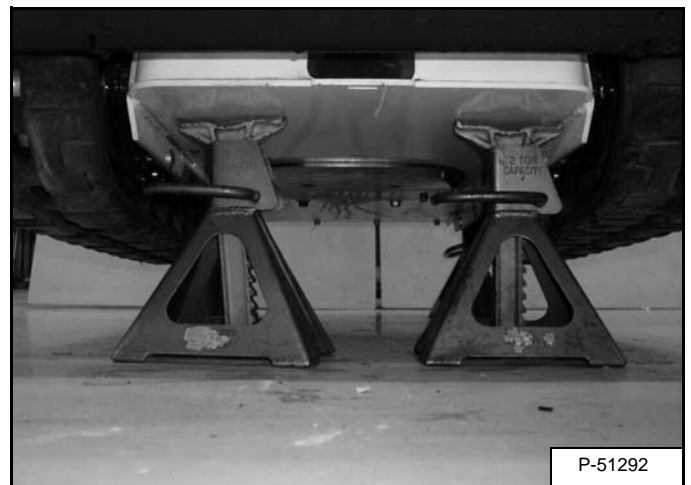

Raise the front of the machine and put jackstands under the front of the frame. [Figure 10-10-3]. Lower the machine to the jackstands.

**NOTE:** Make sure the jackstands do not touch the tracks.

## LIFTING AND BLOCKING THE LOADER (CONT'D)

### Four Point Lift

Figure 10-10-4



The loader can be lifted using four attachment points; two at the lower front of the loader frame and two at the upper end of the uprights [Figure 10-10-4].

Be sure the lifting devices are of adequate strength to lift the loader. (See LOADER SPECIFICATIONS on Page SPEC-10-1.)

## LIFT ARM SUPPORT DEVICE

### Installing

# ! WARNING

Never work on a machine with the lift arms up unless the lift arms are secured by an approved lift arm support device. Failure to use an approved lift arm support device can allow the lift arms or attachment to fall and cause injury or death.

W-2059-0598

# ! WARNING

Service lift arm support device if damaged or if parts are missing. Using a damaged lift arm support or with missing parts can cause lift arms to drop causing injury or death.

W-2271-1197

Put the mini loader on a flat, level surface.

Remove any attachment from the mini loader.

Figure 10-20-1

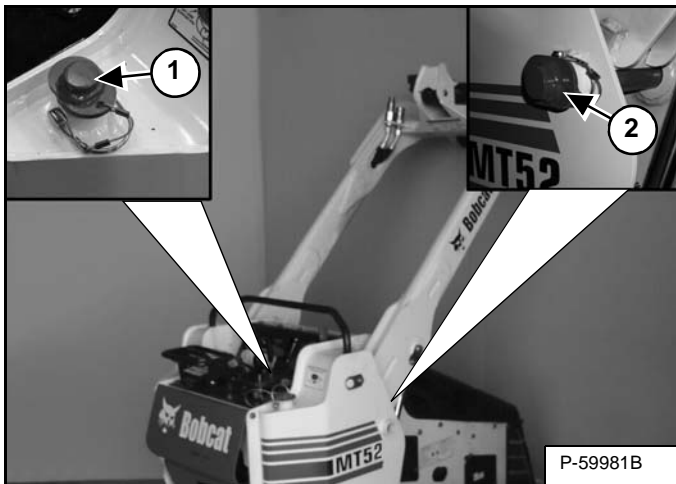

Remove the retainer pin and remove the lift arm support device (Item 1) [Figure 10-20-1] from the storage position.

Start the engine, and raise the lift arms all the way up.

Install the lift arm support device (Item 2) [Figure 10-20-1] into the machine frame bushings and secure with retainer pin.

Slowly lower the lift arms until movement stops.

Stop the engine.

### Removing

Start the engine and raise the lift arms off the lift arm support device.

Remove the retainer pin (Item 1) and remove the lift arm support device (Item 2) [Figure 10-20-1].

Lower the lift arms and stop the engine.

Return the lift arm support device to the storage location.

Install the retainer pin to secure the lift arm support device.

## TRANSPORTING THE BOBCAT LOADER

### Procedure



Adequately designed ramps of sufficient strength are needed to support the weight of the machine when loading onto a transport vehicle. Wood ramps can break and cause personal injury.

W-2058-0494

Figure 10-30-1

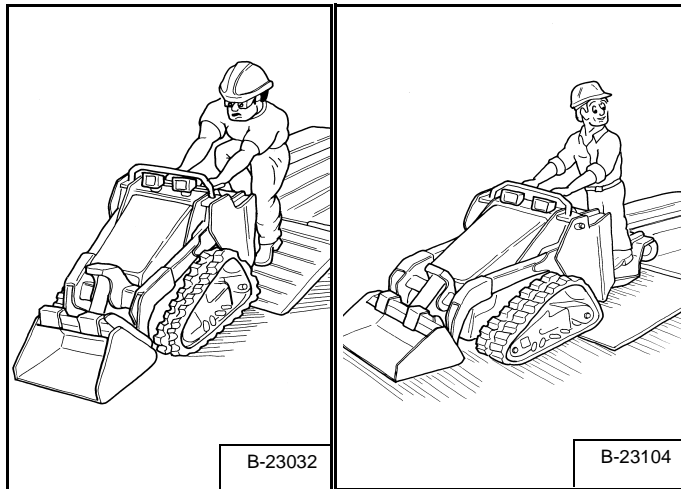

Be sure the trailer or vehicle and ramps are of adequate size and capacity. (See LOADER SPECIFICATIONS on Page SPEC-10-1.)

A mini loader with an empty bucket or no attachment must be loaded backward onto the transport vehicle [Figure 10-30-1].

Use a full width ramp when loading a machine with Ride-On Platform [Figure 10-30-1]. The platform will pivot as you move up the ramp.

**NOTE: Do not load the machine on a trailer with the Ride-On Platform installed unless you have a full width ramp. Remove the platform if a full width ramp is not available.**

When using adjustable ramps, be sure the ramp width and spacing adequately cover the tread width. Do not attempt to mount ramps that are spaced too wide or too narrow.

The rear of the trailer must be blocked or supported (Item 1) [Figure 10-30-1] when loading or unloading the loader to prevent the front end of the trailer from raising up.

Figure 10-30-2

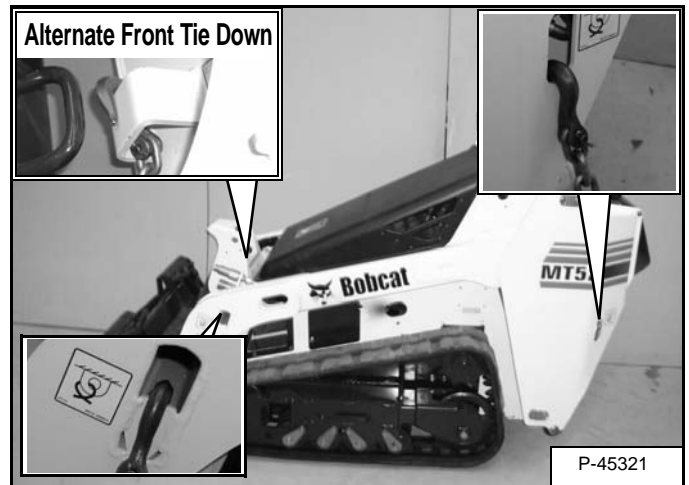

Use the following procedure to fasten the Bobcat loader to the transport vehicle to prevent the loader from moving during sudden stops or when going up or down slopes [Figure 10-30-2].

- Lower the bucket or attachment all the way.
- Stop the engine and engage the parking brake.
- Install chains at the front and rear loader tie down positions [Figure 10-30-2]. (Both sides)
- Fasten each end of the chain to the transport vehicle.

## **TOWING THE LOADER**

### **Procedure**

**TOWING IS NOT RECOMMENDED**

## SERVICE SCHEDULE

### Chart

Maintenance work must be done at regular intervals. Failure to do so will result in excessive wear and early failures. The service schedule is a guide for correct maintenance of the Bobcat Mini Loader

 <b style="font-size: 24pt; margin-left: 10px;">WARNING</b>	<p><b>Instructions are necessary before operating or servicing machine. Read and understand the Operation &amp; Maintenance Manual and signs (decals) on machine. Follow warnings and instructions in the manuals when making repairs, adjustments or servicing. Check for correct function after adjustments, repairs or service. Untrained operators and failure to follow instructions can cause injury or death.</b></p> <p style="text-align: right; font-size: 10pt;">W-2003-0199</p>
----------------------------------------------------------------------------------------------------------------------------------------------	---------------------------------------------------------------------------------------------------------------------------------------------------------------------------------------------------------------------------------------------------------------------------------------------------------------------------------------------------------------------------------------------------------------------------------------------------------------------------------------------

SERVICE SCHEDULE		HOURS					
ITEM	SERVICE REQUIRED	8-10	50	100	■ 250	■ 500	■ 1000
Engine Oil	Check the oil level and add as needed. Do not overfill.						
Engine Air Filter and Air System	Check condition indicator. Service only when required. Check for leaks and damaged components.						
Engine and Hydraulic Cooling System	Clean debris from oil cooler and radiator. Check coolant level COLD. Add premixed coolant as needed.						
Fuel Filter	Remove trapped water.						
Hydraulic Fluid	Check fluid level and add as needed. Do not overfill.						
Lift Arms, Cylinders, Bob-Tach Pivot Pins and Wedges, Ride-On Platform Tire Assembly	Lubricate with multi-purpose lithium based grease.						
Track Rollers & Idlers	Grease the track rollers & idlers.						
Reverse Stop Panel	Inspect for correct function. Adjust or replace as needed. Clean dirt or debris from moving parts.						
Neutral Start Interlocks	Inspect for correct function. Repair or replace as needed.						
Lift / Tilt Lockouts	Inspect for correct function. Repair or replace as needed.						
Parking Brake	Check operation.						
Safety Signs	Check for damaged signs (decals). Replace any signs that are damaged or worn.						
Gauges, Indicators & Lights (Opt.)	Check for correct operation of all gauges indicators & lights.						
Hydraulic Fluid, Hoses and Tubelines	Check fluid level and add as needed. Check for damage and leaks. Repair or replace as needed.						
Control Levers	Check for correct operation. Repair or adjust as needed.						
Under carriage	Check for loose bolts and nuts.						
Tracks	Check for damaged or worn tracks and correct tension.						
Engine Compartment	Check for dirt or debris on the floor of the engine compartment and clean as necessary.						
Battery	Check cables, connections and electrolyte level. Add distilled water as needed.						
Water Pump / Alternator / Fan Belt	Check belt tension and adjust or replace as needed.						
Engine Oil and Filter	Replace oil and filter. Use CD or better grade oil and Bobcat filter.						
Spark Arrestor Muffler	Clean the spark chamber.						
Fuel Filter	Replace the filter. Use a genuine Bobcat filter.						
Control Levers	Lubricate with multi-purpose lithium based grease.						
Lift Arm Lockout	Check function of manual by-pass control.						
Hydraulic Filter	Replace the filter.						
Hydraulic Reservoir Breather Cap	Replace the reservoir breather cap.						
Hydraulic Reservoir	Replace the fluid.						
Coolant	Replace the coolant	Every 2 years					

- Or every 12 months.
- Check every 8-10 hours for the first 50 hours of operation; then at 50 hour intervals.
- \* First oil and filter change must occur at 50 hours; 100 hours thereafter.
- Replace filter after the first 50 hours; 500 hours thereafter.

## AIR CLEANER SERVICE

### Replacing The Filter Elements (Early Models)

It is important to change the air filter at regular intervals.

(See SERVICE SCHEDULE on Page 10-50-1) for the correct interval.

**Figure 10-60-1**

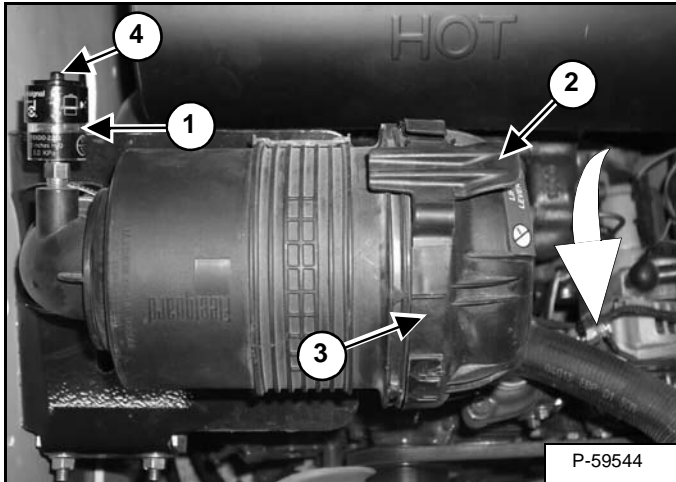

Replace the Outer Filter only when the red ring shows in the condition indicator window (Item 1) [Figure 10-60-1].

Replace the inner filter every third time the outer filter is replaced or as indicated below.-

#### Outer Filter

Pull up on the locking tab (Item 2) [Figure 10-60-1] and hold while turning the dust cover (Item 3) [Figure 10-60-1] counterclockwise 1/8 turn.

Remove and clean the dust cover.

**Figure 10-60-2**

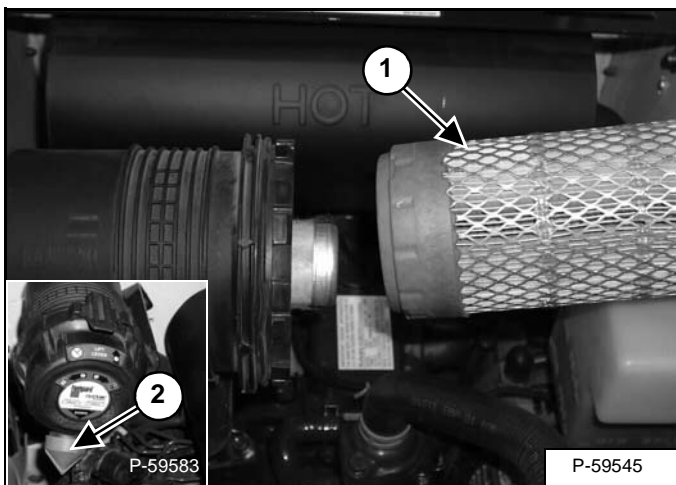

Remove the outer filter (Item 1) [Figure 10-60-2].

**NOTE: Make sure all sealing surfaces are free of dirt and debris. Do not use air pressure to clean.**

Install a new outer filter.

Install the dust cover. Be sure the air cleaner valve (Item 2) [Figure 10-60-2] is down. Turn cover clockwise 1/8 turn and engage the locking tab.

Check the air intake hose and the air cleaner housing for damage. Make sure all connections are tight.

Press the button (Item 4) [Figure 10-60-1] to remove the red ring on the condition indicator.

#### Inner Filter

Only replace the inner filter under the following conditions:

- Replace the inner filter every *third* time the outer filter is replaced.
- After the outer filter has been replaced, press the button (Item 4) [Figure 10-60-1] on the top of the condition indicator and start the engine. Run at full RPM, then reduce engine speed and stop the engine. If the red ring shows in the condition indicator, replace the inner filter.

**Figure 10-60-3**

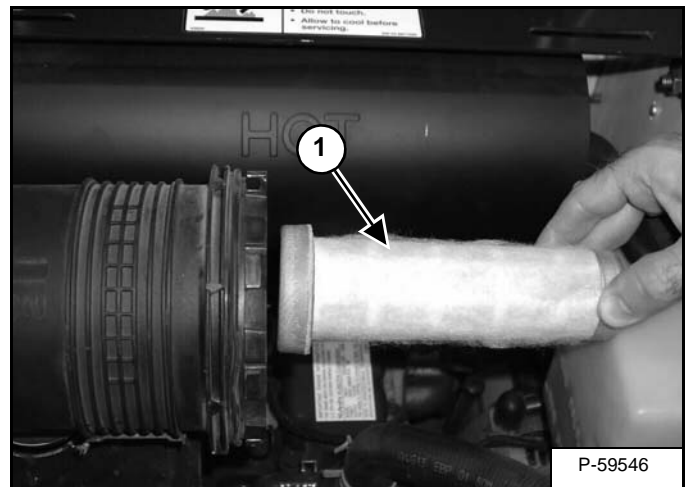

Remove the dust cover, outer filter and inner filter.

**NOTE: Make sure all sealing surfaces are free of dirt and debris.**

Install the new inner filter (Item 1) [Figure 10-60-3].

Install the outer filter.

Install the dust cover. Be sure the air cleaner valve (Item 2) [Figure 10-60-2] is down. Turn cover clockwise 1/8 turn to engage the latch.

Press the button (Item 4) [Figure 10-60-1] on the condition indicator to remove the red ring.

## AIR CLEANER SERVICE (CONT'D)

### Replacing The Filter Elements (Later Models)

It is important to change the air filter element at regular intervals.

(See SERVICE SCHEDULE on Page 10-50-1) for the correct interval.

**Figure 10-60-4**

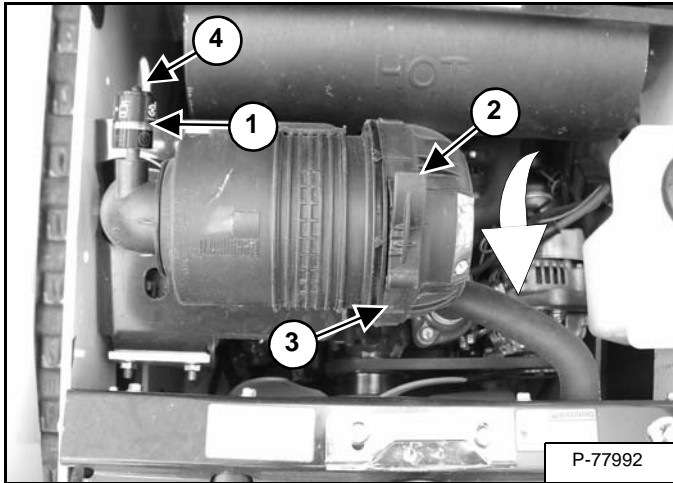

Replace the Outer Filter only when the red ring shows in the condition indicator window (Item 1) [Figure 10-60-4].

Replace the inner filter every third time the outer filter is replaced or as indicated below.

#### Outer Filter

Pull up on the locking lever (Item 2) [Figure 10-60-4] and hold while turning the dust cover (Item 3) [Figure 10-60-4] counterclockwise.

Remove and clean the dust cover.

**Figure 10-60-5**

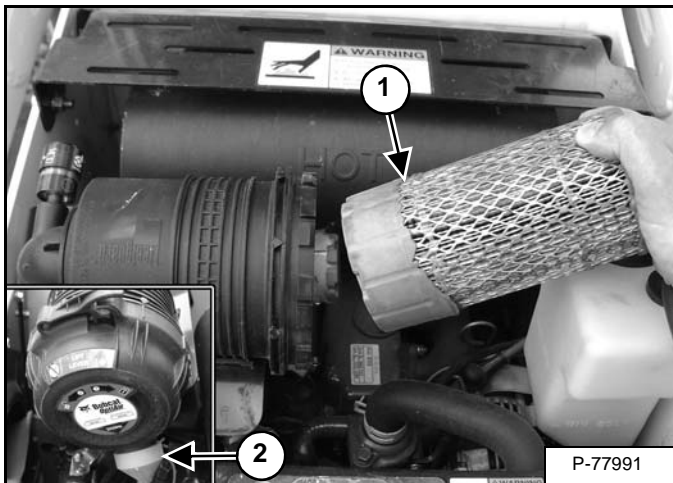

Remove the outer filter element (Item 1) [Figure 10-60-5].

**NOTE: Make sure all sealing surfaces are free of dirt and debris. Do not use air pressure to clean.**

Install a new outer filter element.

Install the dust cover. Be sure the air cleaner valve (Item 2) [Figure 10-60-5] is down. Turn the dust cover clockwise and engage the locking lever.

Check the air intake hose and the air cleaner housing for damage. Make sure all connections are tight.

Press the button (Item 4) [Figure 10-60-4] to remove the red ring on the condition indicator.

#### Inner Filter

Only replace the inner filter under the following conditions:

- Replace the inner filter every *third* time the outer filter is replaced.
- After the outer filter has been replaced, press the button (Item 4) [Figure 10-60-4] on the top of the condition indicator and start the engine. Run at full RPM, then reduce engine speed and stop the engine. If the red ring shows in the condition indicator, replace the inner filter.

**Figure 10-60-6**

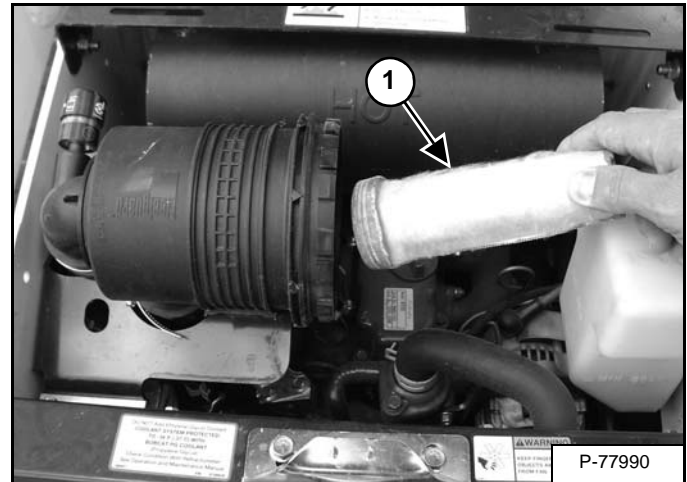

Remove the dust cover, outer filter and inner filter.

**NOTE: Make sure all sealing surfaces are free of dirt and debris.**

Install the new inner filter (Item 1) [Figure 10-60-6].

Install the outer filter.

Install the dust cover. Be sure the air cleaner valve (Item 2) [Figure 10-60-5] is down. Turn cover clockwise 1/8 turn to engage the latch.

Press the button (Item 4) [Figure 10-60-4] on the condition indicator to remove the red ring.

## ENGINE COOLING SYSTEM

Check the cooling system every day to prevent overheating, loss of performance or engine damage.

### Checking The Coolant Level

Make sure the engine is cool.

Figure 10-70-1

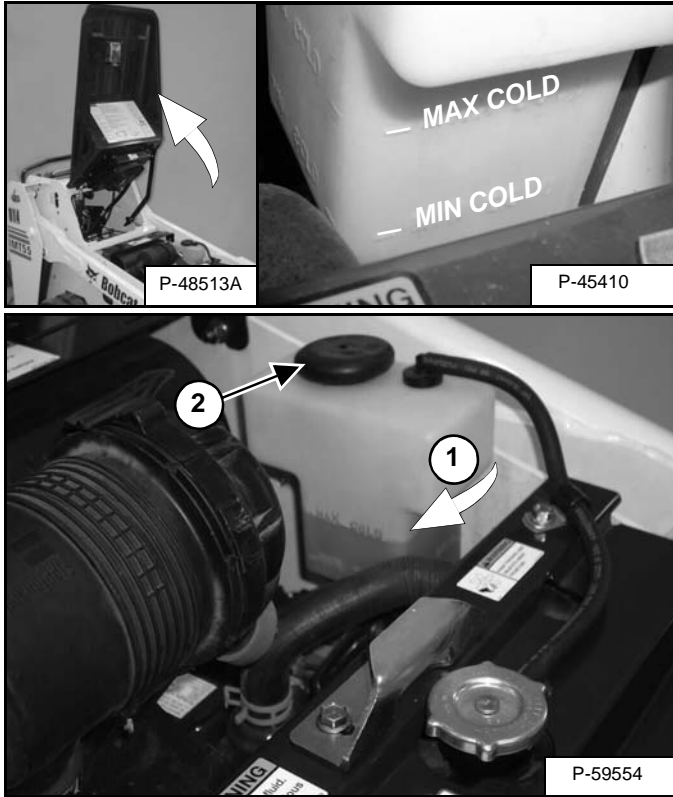

Raise the hood [Figure 10-70-1].

Check coolant level in the recovery tank (Item 1) [Figure 10-70-1].

Remove the cap (Item 2) [Figure 10-70-1] from the recovery tank.

Add premixed coolant to the recovery tank until it is at the MAX level.

# IMPORTANT

## AVOID ENGINE DAMAGE

Always use the correct ratio of water to antifreeze.

Too much antifreeze reduces cooling system efficiency and may cause serious premature engine damage.

Too little antifreeze reduces the additives which protect the internal engine components; reduces the boiling point and freeze protection of the system.

Always add a premixed solution. Adding full strength concentrated coolant can cause serious premature engine damage.

I-2124-0497

## ENGINE COOLING SYSTEM (CONT'D)

### Cleaning The Cooling System

Open the hood [Figure 10-70-1].

Figure 10-70-2

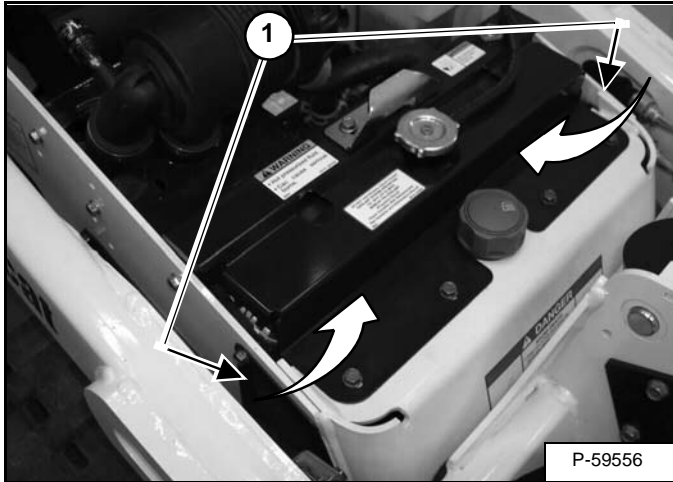

Remove screen covers (Item 1) [Figure 10-70-2] from both sides of the machine.

Use low air pressure or water pressure to clean the radiator through the side screens.

Install screen covers.

Close and latch the hood.

## WARNING

Wear safety glasses to prevent eye injury when any of the following conditions exist:

- When fluids are under pressure.
- Flying debris or loose material is present.
- Engine is running.
- Tools are being used.

W-2019-1285

## Replacing The Coolant

Raise the hood.

## WARNING

### AVOID BURNS

Do not remove radiator cap when the engine is hot. You can be seriously burned.

W-2070-1285

Figure 10-70-3

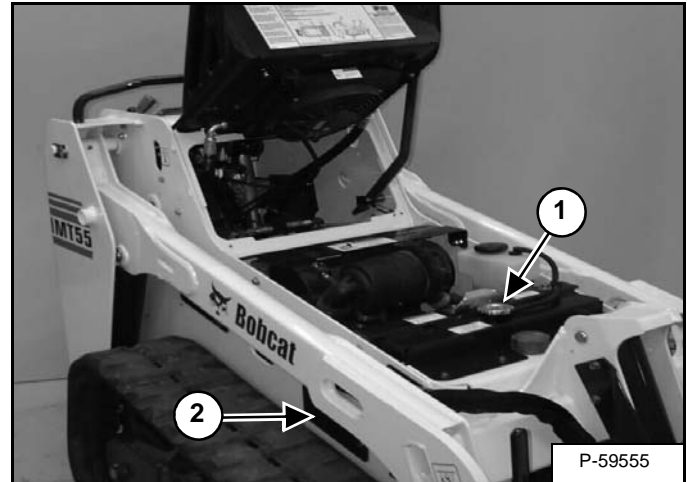

Remove the radiator cap (Item 1) [Figure 10-70-3] when the engine is cool.

Loosen the thumb nut and turn the access cover (Item 2) [Figure 10-70-3] open.



**Suggest:**

**If the above button click is invalid.**

**Please download this document**

**first, and then click the above link**

**to download the complete manual.**

**Thank you so much for reading**

## ENGINE COOLING SYSTEM (CONT'D)

### Replacing the Coolant (Cont'd)

Figure 10-70-4

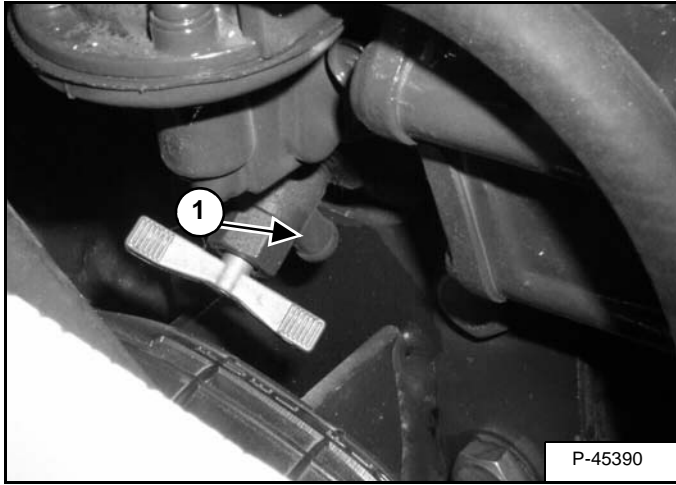

Connect a hose to the engine block drain valve (Item 1) [Figure 10-70-4] on the right side of the engine.

Open the valve and drain the coolant into a container. After the coolant is removed, close the drain valve and remove the hose.

Recycle or dispose of coolant in an environmentally safe manner.

**NOTE: The mini loader is factory filled with propylene glycol coolant (purple color). DO NOT mix propylene glycol with ethylene glycol.**

Mix new coolant in a separate container.

One gallon and one pint (4,3 L) of propylene glycol mixed with one gallon (3,8 L) of water is the correct mixture of coolant (47% water and 53% propylene glycol) to provide a -34°F (-37°C) freeze protection.

Add premixed coolant, to the radiator. Install the radiator cap.

Add premixed coolant to the coolant recovery tank.

# IMPORTANT

## AVOID ENGINE DAMAGE

Always use the correct ratio of water to antifreeze.

Too much antifreeze reduces cooling system efficiency and may cause serious premature engine damage.

Too little antifreeze reduces the additives which protect the internal engine components; reduces the boiling point and freeze protection of the system.

Always add a premixed solution. Adding full strength concentrated coolant can cause serious premature engine damage.

I-2124-0497

Use a refractometer to check the condition of propylene glycol in your cooling system.

Run the engine until it is at operating temperature. Stop the engine. Check the coolant level when cool. Add coolant as needed.

Close the hood.

**<https://www.ebooklibonline.com>**

Hello dear friend!

Thank you very much for reading.

Enter the link into your browser.

The full manual is available for immediate download.

**<https://www.ebooklibonline.com>**