

**Workmate
2100
2100S**



**Bobcat®
Maintenance
and
Service** 

**S/N 522711001 & Above
S/N 524411001 & Above**

Utility Vehicle

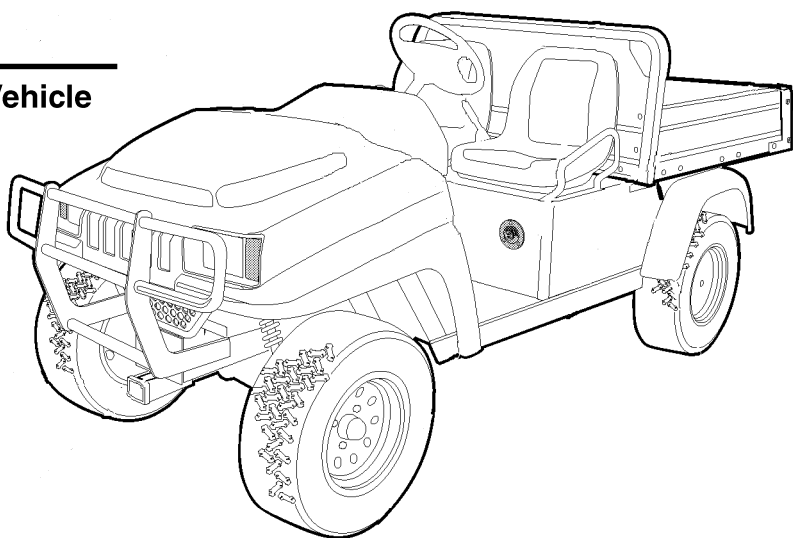

An  **Ingersoll-Rand** business

FOREWORD

Bobcat vehicles are designed and built to provide the ultimate in performance efficiency; however, proper maintenance and repair are essential for achieving maximum service life and continued safe and reliable operation.

This manual provides detailed information for the maintenance and repair of the Bobcat 1200 and Bobcat 1200S vehicles, and should be thoroughly reviewed prior to servicing the vehicles. The procedures provided must be properly implemented, and the DANGER, WARNING, and CAUTION statements must be heeded.

This manual was written for the trained technician who already possesses knowledge and skills in electrical and mechanical repair. *If the technician does not have such knowledge and skills, attempted service or repairs to the vehicle may render the vehicle unsafe.* For this reason, Bobcat Company advises that all repairs and/or service be performed by an authorized Bobcat 2100 and 2100S distributor/dealer representative or by a Bobcat factory-trained technician.

It is the policy of Bobcat Company to assist its distributors and dealers in continually updating their service knowledge and facilities so they can provide prompt and efficient service for vehicle owners. Regional technical representatives, vehicle service seminars, periodic service bulletins, maintenance and service manuals, and other service publications also represent Bobcat Company's continuing commitment to customer support.

This manual covers all aspects of typical vehicle service; unique situations, however, do sometimes occur when servicing a vehicle. If it appears that a service question is not answered in this manual, you may **write to us at: P.O. Box 204658; Augusta, Georgia 30917; Attention: Technical Services, or contact a Club Car Technical Service Representative at (706) 863-3000, ext. 3580.**

Copyright © 2003 Bobcat Company.

This manual effective August, 2003.

WARNING

- Read SECTION 1–SAFETY before attempting any service on this vehicle.
- Before servicing vehicle, read complete section(s) and any referenced information that may be relevant to the service or repair to be performed.

NOTE: *This manual represents the most current information at the time of publication. Bobcat Company is continually working to further improve our vehicles and other products. These improvements may affect servicing procedures. Any modification and/or significant change in specifications or procedures will be forwarded to all Bobcat 2100 and 2100S dealers and will, when applicable, appear in future editions of this manual.*

Bobcat Company reserves the right to change specifications and designs at any time without notice and without the obligation of making changes to units previously sold.

There are no warranties expressed or implied in this manual. See the limited warranty found in the vehicle Operation and Maintenance Manual.

CONTENTS

SECTION 1 – SAFETY

General Warning	1-1
-----------------------	-----

SECTION 2 – VEHICLE SPECIFICATIONS

SECTION 3 – GENERAL INFORMATION

General Information	3-1
Serial Number Identification	3-1
Storage	3-2
Preparing the Vehicle for Extended Storage	3-2
To Return Vehicle to Service	3-2

SECTION 4 – BODY AND TRIM

Cleaning the Vehicle	4-1
Front Body Repair	4-1
Abrasions and Haze	4-1
Light Scratches	4-2
Large Scratches and Abrasions	4-2
Front Body Components	4-2
Dashboard Removal	4-2
Dashboard Installation	4-2
Front Body Removal	4-3
Front Fender Removal	4-3
Front Fender Installation	4-4
Front Body Installation	4-4
Seat	4-4
Seat Adjustment	4-4
Front Seat Support	4-6
Front Seat Support Removal	4-6
Front Seat Support Installation	4-7
Rear Seat Support	4-7
Rear Seat Support Removal	4-7
Rear Seat Support Installation	4-7

<https://www.ebooklibonline.com>

Hello dear friend!

Thank you very much for reading.

Enter the link into your browser.

The full manual is available for immediate download.

<https://www.ebooklibonline.com>

Cargo Bed	4-9
Cargo Bed Removal	4-9
Cargo Bed Installation	4-9
Bed Stop Bumper Adjustment	4-11
Rear Fender Removal	4-12
Rear Fender Installation	4-12
Tailskirt	4-12
Tailskirt Removal	4-12
Tailskirt Installation	4-12
Receiver Hitch	4-12
Receiver Hitch Removal	4-12
Receiver Hitch Installation	4-13
Floor Mat	4-14
Floor Mat Removal	4-14
Floor Mat Installation	4-14

SECTION 5 – ACCELERATOR AND BRAKE PEDAL ASSEMBLIES

Brake Pedal	5-1
Brake Pedal Removal	5-1
Brake Pedal Installation	5-1
Brake Pedal Adjustment	5-2
Accelerator Pedal	5-4
Accelerator Pedal Removal	5-4
Accelerator Pedal Installation	5-5
Accelerator Pedal Adjustment	5-5

SECTION 6 – MC012C-AS00 TRANSAXLE: HYDRAULIC AND PARK BRAKE SYSTEMS

Brake System Inspection	6-1
Brake System Troubleshooting	6-3
Brake Drum Removal	6-6
Front Wheel Brake Drum Removal	6-6
Rear Wheel Brake Drum Removal	6-8
Brake Shoe Removal	6-8
Front Brake Shoe Removal	6-8
Rear Brake Shoe Removal	6-9
Brake Cluster Inspection and Cleaning	6-10
Brake Shoe Installation	6-11
Front Brake Shoe Installation	6-12
Rear Brake Shoe Installation	6-12

Brake Drum Installation	6-14
Front Wheel Brake Drum Installation	6-14
Rear Wheel Brake Drum Installation	6-16
Brake Cluster Assembly Replacement	6-17
Front Brake Cluster Assembly Removal	6-17
Front Brake Cluster Assembly Installation	6-17
Rear Brake Cluster Assembly Removal	6-18
Rear Brake Cluster Assembly Installation	6-19
Wheel Cylinder Replacement	6-19
Front Wheel Cylinder Removal	6-19
Front Wheel Cylinder Installation	6-20
Rear Wheel Cylinder Removal	6-20
Rear Wheel Cylinder Installation	6-20
Brake Shoe Adjuster Replacement	6-21
Front Brake Shoe Adjuster Removal	6-22
Front Brake Shoe Adjuster Installation	6-22
Rear Brake Shoe Adjuster Removal	6-22
Rear Brake Shoe Adjuster Installation	6-22
Hydraulic Line and Hose Replacement	6-23
Front Brake Line Removal	6-23
Front Brake Line Installation	6-23
Front Brake Hose Assembly Removal	6-24
Front Brake Hose Assembly Installation	6-24
Rear Brake Line Removal	6-24
Rear Brake Line Installation	6-26
Rear Brake Hose Removal	6-26
Rear Brake Hose Installation	6-27
Master Cylinder And Bell Crank Replacement	6-27
Bell Crank Removal	6-27
Bell Crank Installation	6-27
Master Cylinder Removal	6-29
Master Cylinder Installation	6-29
Bleeding the Hydraulic Brake System	6-31
Purging the Hydraulic System	6-32
Filling the Hydraulic System	6-32
Park Brake System	6-33
Park Brake Cable Removal	6-33
Park Brake Cable Installation	6-34
Park Brake Handle Removal	6-35
Park Brake Handle Installation	6-35
Park Brake Adjustment	6-35

SECTION 7 – STEERING AND FRONT SUSPENSION

Steering Wheel	7-1
Steering Wheel Removal	7-1
Steering Wheel Installation	7-3
Steering Column	7-3
Steering Column Removal	7-3
Steering Column Disassembly	7-3
Steering Column Assembly	7-4
Steering Column Installation	7-4
Rack and Pinion	7-5
Rack and Pinion Removal	7-5
Rack and Pinion Disassembly	7-6
Rack and Pinion Assembly	7-9
Rack and Pinion Installation	7-10
Front Suspension	7-12
Lubrication	7-12
Wheel Alignment	7-12
Front Suspension Components	7-14
Kingpin and Steering Spindle Removal	7-14
Kingpin and Steering Spindle Installation	7-14
A-Arm Removal	7-15
A-Arm Installation	7-17
Shock Absorber Removal	7-17
Shock Absorber Installation	7-18
Front Wheel Bearings and Hubs	7-18
Front Wheel Free Play Inspection	7-18
Front Wheel Bearings and Hub Removal	7-19
Front Wheel Bearings and Hub Installation	7-19

SECTION 8 – WHEELS AND TIRES

General Information	8-1
---------------------------	-----

SECTION 9 – REAR SUSPENSION

Shock Absorbers	9-1
Shock Absorber Removal and Inspection	9-1
Shock Absorber Installation	9-1
Multi-Leaf Springs	9-1
Multi-Leaf Spring Removal	9-1
Multi-Leaf Spring Installation	9-3

Snubber	9-4
Snubber Removal	9-4
Snubber Installation	9-4

SECTION 10 – PERIODIC MAINTENANCE

Periodic Service Schedule	10-1
Periodic Lubrication Schedule	10-2
Master Cylinder	10-3
Brake Fluid	10-4
Engine Oil	10-4
Engine Oil Level Check	10-4
Engine Oil and Filter Change	10-5
Oil Viscosity	10-7
Fueling Instructions	10-7
Battery	10-8

SECTION 11 – TROUBLESHOOTING AND ELECTRICAL SYSTEM: FE400 ENGINE

Troubleshooting Guide	11-1
Electrical System	11-5
Wiring Diagram	11-6
Electrical Circuits	11-8
Starter Circuit	11-8
Generator Circuit	11-8
Engine Ignition Circuit	11-9
Engine Kill Circuit	11-9
Reverse Buzzer Circuit	11-10
Low Oil Warning Circuit	11-10
Lockout Cam Circuit	11-11
Fuel Gauge and Sending Unit Circuit	11-12
Hour Meter Circuit	11-13
Lighting Circuit	11-13
Circuit Testing	11-13
Testing the Starter Circuit and Generator Circuit	11-14
Testing the Engine Ignition Circuit	11-15
Testing the Engine Kill Circuit	11-15
Testing the Reverse Buzzer Circuit	11-16
Testing the Low Oil Warning Circuit	11-17
Testing the Lockout Cam Circuit	11-18
Testing the Fuel Gauge and Sending Unit Circuit	11-18
Testing the Lighting Circuit	11-19

Test Procedures	11-19
Index of Test Procedures	11-19

SECTION 12 – ELECTRICAL COMPONENTS: FE400 ENGINE

Starter/Generator	12-1
Voltage Regulator	12-11
Diode	12-12
Key Switch	12-14
Solenoid	12-15
Fuse	12-15
Lockout Cam Limit Switch	12-17
Lockout Cam	12-17
Reverse Warning Buzzer	12-18
Reverse Buzzer Limit Switch	12-19
Low Oil Warning Light	12-20
Fuel Gauge/Hour Meter	12-21
Fuel Level Sending Unit	12-22
RPM Limiter	12-22
Ignition Coil	12-23
Oil Level Sensor	12-26
Headlights	12-26
Headlight Diode	12-27
Light Switch	12-28
Testing the Light Switch	12-28
Battery	12-28
General Information	12-29
Ground Straps	12-33

SECTION 13 – FE400 ENGINE

General Information	13-1
Before Servicing	13-1
Lubrication System	13-1
Spark Plug	13-1
Cylinder	13-3
Breather Valve (Reed Valve)	13-3
Valve Clearance Check and Adjustment	13-3
Crankcase	13-3
Engine Removal	13-3
Crankcase Cover Removal	13-4
Oil Level Sensor	13-5

Ignition Coil and Flywheel	13-6
Crankcase Cover Installation	13-7
Flywheel Installation	13-7
Engine Installation	13-8
Torque Specifications	13-9
Adjustment and Settings	13-9

SECTION 14 – FUEL SYSTEM

General Information	14-1
Carburetor	14-1
Main Jet Elevation/Size Chart	14-1
Changing the Main Jet	14-2
Engine Control Linkage	14-5
General Information	14-5
Accelerator Rod	14-6
Governor Cable	14-7
Accelerator Cable	14-8
Closed Throttle or Idle Adjustment	14-10
Engine RPM Adjustment	14-10
Choke and Air Intake System	14-11
Choke Cable Removal	14-11
Choke Cable Installation	14-11
Air Box Removal	14-11
Air Box Installation	14-12
Intake Duct Repair	14-13
Intake Duct Removal	14-13
Intake Duct Installation	14-15
Air Filter	14-16
Fuel Filter Removal	14-17
Fuel Filter Installation	14-17
Fuel Pump	14-17
General Information	14-17
Fuel Pump Removal	14-20
Fuel Pump Disassembly	14-20
Fuel Pump Cleaning and Inspection	14-20
Fuel Pump Assembly	14-21
Fuel Pump Installation	14-21
Fuel Tank	14-22
Fuel Tank Removal	14-22
Fuel Tank Storage or Disposal	14-26
Fuel Tank Installation	14-26

Fuel Lines	14-27
Fuel Shut-Off Valve	14-28

SECTION 15 – EXHAUST SYSTEM

Muffler	15-1
Muffler Removal	15-1
Muffler Installation	15-1

SECTION 16 – MC012C-AS00 UNITIZED TRANSAXLE WITH DIFFERENTIAL LOCK

General Information	16-1
Lubrication	16-2
Axle Shaft	16-3
Axle Shaft, Bearing, and Oil Seal Removal	16-3
Axle Bearing Removal	16-5
Axle Shaft, Bearing, and Oil Seal Installation	16-5
Unitized Transaxle Removal	16-6
Unitized Transaxle Installation	16-16
Forward/Reverse Shifter Cable	16-24
Forward/Reverse Shifter Cable Removal	16-24
Forward/Reverse Shifter Cable Installation	16-24
Forward/Reverse Shifter Cable Adjustment	16-25
Differential Lock System	16-26
Differential Lock System Inspection	16-26
Differential Lock Cable Removal	16-26
Differential Lock Cable Installation	16-27

SECTION 17 – TORQUE CONVERTER

General Information	17-1
Drive Belt	17-3
Drive Belt Removal	17-3
Drive Belt Installation	17-4
Drive Clutch	17-4
Drive Clutch Removal	17-4
Drive Clutch Cleaning and Inspection	17-5
Drive Clutch Disassembly	17-6
Inspection of Drive Clutch Parts	17-7
Drive Clutch Assembly	17-9
Drive Clutch Installation	17-12

Driven Clutch	17-13
Driven Clutch Removal	17-13
Driven Clutch Disassembly	17-13
Driven Clutch Inspection	17-13
Driven Clutch Assembly	17-15
Driven Clutch Installation	17-17

SECTION i – INDEX

SECTION 1 – SAFETY

To ensure the safety of those servicing Bobcat Company vehicles, and to protect the vehicles from damage resulting from improper service or maintenance, the procedures in this manual must be followed. It is important to note that throughout this manual there are statements contained within headings labeled DANGER, WARNING, CAUTION, or NOTE. These special statements relate to specific safety issues, and must be read, understood, and heeded before proceeding.

DANGER

- A DANGER indicates an immediate hazard that will result in severe personal injury or death.

WARNING

- A WARNING indicates an immediate hazard that could result in severe personal injury or death.

CAUTION

- A CAUTION indicates a hazard or unsafe practice that could result in product or property damage or minor personal injury.

CAUTION

- A CAUTION without the safety alert symbol indicates a potentially hazardous situation that could result in property damage.

GENERAL WARNING

The following safety procedures must be followed whenever the vehicle is being operated, repaired, or serviced. Service technicians should become familiar with these general statements, which can be found throughout this manual. Also, other specific warnings appear throughout this manual and on the vehicle.

DANGER

- **Battery – Explosive gases! Do not smoke. Keep sparks and flames away from the vehicle and service area. Ventilate when charging or operating vehicle in an enclosed area. Wear a full face shield and rubber gloves when working on or near batteries.**
- **Battery – Poison! Contains acid! Causes severe burns. Avoid contact with skin, eyes, or clothing. Antidotes:**
 - **External: Flush with water. Call a physician immediately.**
 - **Internal: Drink large quantities of milk or water. Follow with milk of magnesia or vegetable oil. Call a physician immediately.**
 - **Eyes: Flush with water for 15 minutes. Call a physician immediately.**
- **Gasoline – Flammable! Explosive! Do not smoke. Keep sparks and flames away from the vehicle and service area. Service only in a well-ventilated area.**
- **Do not operate gasoline vehicle in an enclosed area without proper ventilation. The engine produces carbon monoxide, which is an odorless, deadly poison.**

 WARNING

- Follow the procedures exactly as stated in this manual, and heed all DANGER, WARNING, and CAUTION statements in this manual as well as those on the vehicle.
- Only trained technicians should service or repair the vehicle. Anyone doing even simple repairs or service should have knowledge and experience in electrical and mechanical repair. The appropriate instructions must be used when performing maintenance, service, or accessory installation.
- Prior to servicing the vehicle or leaving the vehicle unattended, turn the key switch OFF, remove the key, and place the Forward/Reverse handle in the NEUTRAL position. Chock the wheels when servicing the vehicle.
- To avoid unintentionally starting the vehicle:
 - Disconnect battery cables, negative (–) cable first (Figure 1-1, Page 1-3).
 - Disconnect the spark plug wire from the spark plug.
- Frame ground – Do not allow tools or other metal objects to contact frame when disconnecting battery cables or other electrical wiring. Do not allow a positive wire to touch the vehicle frame, engine, or any other metal component.
- Wear safety glasses or approved eye protection when servicing the vehicle. Wear a full face shield and rubber gloves when working on or near batteries.
- Do not wear loose clothing or jewelry such as rings, watches, chains, etc., when servicing the vehicle.
- Moving parts! Do not attempt to service the vehicle while it is running.
- Hot! Do not attempt to service hot engine or exhaust system. Failure to heed this warning could result in severe burns.
- Use insulated tools when working near batteries or electrical connections. Use extreme caution to avoid shorting of components or wiring.
- Check the vehicle Operation and Maintenance manual for proper location of all vehicle safety and operation decals and make sure they are in place and are easy to read.
- Any modification or change to the vehicle that affects the stability or handling of the vehicle, or increases maximum vehicle speed beyond factory specifications, could result in severe personal injury or death.
- Lift only one end of the vehicle at a time. Use a suitable lifting device (chain hoist or hydraulic floor jack) with 1000 lb. (454 kg) minimum lifting capacity. Do not use lifting device to hold vehicle in raised position. Use approved jack stands of proper weight capacity to support the vehicle and chock the wheels that remain on the floor. When not performing a test or service procedure that requires movement of the wheels, lock the brakes.
- If wires are removed or replaced, make sure wiring and wire harness are properly routed and secured. Failure to properly route and secure wiring could result in vehicle malfunction, property damage, personal injury, or death.
- For vehicles with cargo beds, remove all cargo before raising the bed or servicing the vehicle. If the vehicle is equipped with a prop rod, ensure that it is securely engaged while bed is raised. Do not close bed until all persons are clear of cargo bed area. Keep hands clear of all crush areas. Do not drop cargo bed; lower gently and keep entire body clear. Failure to heed this warning could result in severe personal injury or death.
- Improper use of the vehicle or failure to properly maintain it could result in decreased vehicle performance, severe personal injury, or death.
- Do not leave children unattended on vehicle.

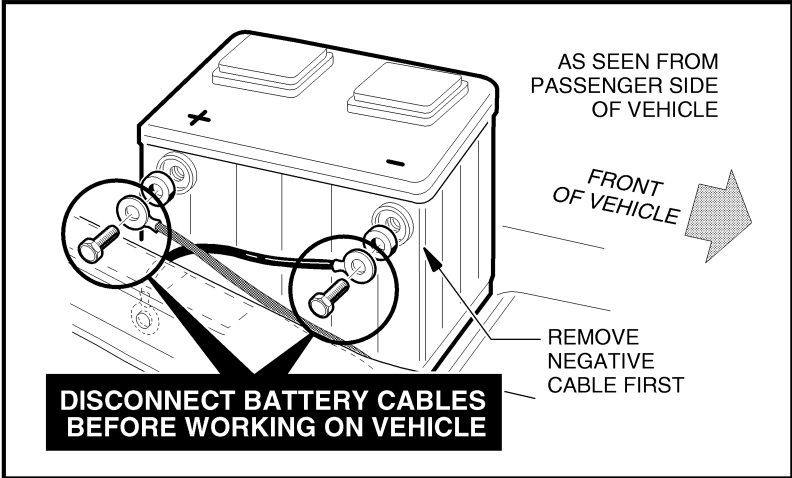

Figure 1-1 Battery

SECTION 2 – VEHICLE SPECIFICATIONS

SPECIFICATIONS	BOBCAT 2100	BOBCAT 2100 S
POWER SOURCE		
Engine: 4-cycle OHV, 400 cc, 13 hp rated, single-cylinder, air-cooled, with pressure lubrication system	•	•
Fuel system: Side-draft carburetor with float bowl, fixed jets, fuel filters, and impulse fuel pump	•	•
Governor: Automatic ground-speed sensing, internally-gearred in unitized transaxle	•	•
Ignition: Transistor electronic ignition with electronic RPM limiter	•	•
Unitized transaxle, MC012C-AS00: Fully synchronized forward and reverse with neutral (14.9:1 forward, 20.5:1 reverse) and differential lock feature	•	•
Electrical system: 12 volt, 500 cca at 0 °F (-17.8 °C), 650 at 32 °F (0 °C). 105-minute reserve capacity and 35-amp charging capacity	•	•
Torque converter: Automatic, variable-speed, dry type	•	•
STEERING/SUSPENSION/BRAKES		
Steering: Self-adjusting rack and pinion, Ackerman	•	•
Suspension: Front: Independent A-arms with coil-over shocks Rear: Semi-independent suspension with multi-leaf springs and dual hydraulic shocks	•	•
Brakes: Hydraulic brake system – self-adjusting drum brakes on each wheel with separate hand-operated park brake	•	•
BODY/CHASSIS		
Frame/Chassis: Twin I-Beam welded aluminum	•	•
Side and rear body: All aluminum with a powder-coated steel cargo bed	•	
Side and rear body: All aluminum with an aluminum cargo bed		•
Front body: ABS/DR acrylic cap	•	•
Tires: 23 x 10.50 - 12 tubeless, 4-ply rated load range, front and rear	•	•
DIMENSIONS/WEIGHT		
Overall length (with box bed)	123.4 in. (313.4 cm)	144.4 in. (366.8 cm)
Overall width	54 in. (137 cm)	
Overall height (at steering wheel)	51 in. (130 cm)	
Overall height (at light bar)	75.3 in. (191 cm)	
Wheelbase	80 in. (203 cm)	101 in. (256 cm)
Ground clearance: under differential under foot platform	6.6 in (17 cm) 11.4 in (29 cm)	
Front wheel tread	43 in. (109 cm)	
Rear wheel tread, MC012C-AS00 transaxle	44.5 in. (113 cm)	
Weight (dry): with all-terrain tread with turf tread	1106 lb. (501.7 kg) 1066 lb. (477.2 kg)	1200 lb. (544.2 kg) 1160 lb. (526.0 kg)
Forward speed	17-19 mph (27-31 km/h)	
Governed RPM	3850 (±30) RPM	
Curb clearance circle (diameter)	24 ft. 1 in. (734 cm)	31 ft. 8 in. (965 cm)
Turning radius (per SAE J 695)	139.6 in. (355 cm)	15 ft. 6 in. (472.4 cm)
Intersecting aisle clearance	112.2 in. (285 cm)	120 in. (304 cm)
Specifications continued on next page...		

SPECIFICATIONS	BOBCAT 2100	BOBCAT 2100 S
Floorboard height	17 in. (43 cm)	
Seat height (at seat bottom)	35 in. (89 cm)	
Load bed height	31.1 in. (79 cm)	
Load bed size (box bed inside dimensions)	48.0 x 49.8 x 10.9 in. (121.9 x 126.4 x 27.6 cm) (15.3 cubic feet)	37.6 x 45.1 x 9.3 in. (96 x 115 x 23 cm) (9.13 cubic feet)
Load bed size (flat bed dimensions)	46.9 x 48.3 in. (119 x 123 cm)	35.8 x 44.3 in. (91 x 112 cm)
Vehicle rated capacity (level surface only)	1200 lb. (544 kg)	1300 lb. (590 kg)
Bed load capacity (level surface only)	800 lb. (363 kg)	500 lb. (227 kg)
Standard seating capacity	2	4
LIQUID CAPACITIES		
Engine crankcase without filter	32 oz. (.95 liters)	
Engine crankcase with filter	38 oz. (1.12 liters)	
Unitized transaxle, MC012C-AS00	29 oz. (.85 liters)	
Master cylinder	8 oz. (240 ml)	
Fuel tank (unleaded gasoline only)	7 gallons (26.5 liters)	6.5 gallons (24.6 liters)
TIRE PRESSURE		
All terrain tread (standard)	Front: 7-11 psi (.48-.76 Bars) Rear: 14-18 psi (.97-1.24 Bars)	Front: 7-11 psi (.48-.76 Bars) Rear: 14-18 psi (.97-1.24 Bars)
Turf tread (optional)	Front: 12-16 psi (.83-1.10 Bars) Rear: 16-20 psi (1.10-1.38 Bars)	Front: 12-16 psi (.83-1.10 Bars) Rear: 16-20 psi (1.10-1.38 Bars)
Traks Max II tread (optional)	Front: 14-16 psi (.97-1.10 Bars) Rear: 18-20 psi (1.24-1.38 Bars)	Front: 14-16 psi (.97-1.10 Bars) Rear: 18-20 psi (1.24-1.38 Bars)

SECTION 3 – GENERAL INFORMATION

GENERAL INFORMATION

Refer to the Operation and Maintenance manual provided with the vehicle for information on the following topics:

- Vehicle Feature Identification
- Controls and Indicators
- Driving Instructions
- Towing with the Vehicle
- Transporting on a Trailer
- Engine Oil and Filter Change
- Accessory Equipment
- Subsequent Owner Registration
- Warranties

SERIAL NUMBER IDENTIFICATION

The serial number of each vehicle is printed on a bar code decal mounted on the frame directly above the accelerator pedal (Example: 522711001) (**Figure 3-1, Page 3-1**) for Bobcat 2100 or (Example: 522411001) (**Figure 3-2, Page 3-1**) for Bobcat 2100S. **See following NOTE.**

NOTE: Have the vehicle serial number available when ordering parts or making inquiries (**Figure 3-1, Page 3-1 or Figure 3-2, Page 3-1**).



Figure 3-1 2100 Serial Number Decal



Figure 3-2 2100S Serial Number Decal

STORAGE

DANGER

- Read General Warning, Section 1, Page 1-1.

WARNING

- Read General Warning, Section 1, Page 1-1.

CAUTION

- Batteries in a low state of charge will freeze at low temperatures.

PREPARING THE VEHICLE FOR EXTENDED STORAGE

1. Store vehicle in a cool dry place.
2. Use a 12-volt battery charger rated 10 amps or less to charge battery.
3. Remove all items from the vehicle so that only the vehicle weight will be placed on the tires.
4. Make sure the key switch is OFF and the Forward/Reverse handle is in NEUTRAL. Chock the wheels.
5. Drain carburetor and seal the fuel tank.
 - 5.1. Turn the fuel shut-off valve to the closed (OFF) position (**Figure 3-6, Page 3-3**) and run the engine until it stalls. **See DANGER "Do not operate gasoline vehicle..." in General Warning, Section 1, Page 1-1.**
6. Disconnect the battery cables as instructed. **See WARNING "To avoid unintentionally starting..." in General Warning, Section 1, Page 1-2.**
7. Loosen the carburetor drain screw and drain fuel in the bowl into a small, clean container and pour the fuel into the vehicle fuel tank. Tighten the carburetor drain screw.
8. Fill fuel tank to about 1 inch (2.5 cm) from top of fuel tank and add a commercially available fuel stabilizer (such as Sta-Bil[®]).
9. Disconnect vent tube from fuel tank vent (**Figure 3-3, Page 3-3 or Figure 3-4, Page 3-3**).
10. Plug the fuel tank vent nipple so that it is air tight using a slip-on vinyl cap.
11. Wash tops and terminals of batteries with a solution of baking soda and water (1 cup (237 mL) baking soda per 1 gallon (3.8 L) of water). Rinse solution off batteries. Do not allow this solution to enter the batteries.
12. Remove spark plug and pour 1/2 ounce of SAE 10 weight oil into the engine through the spark plug hole. Rotate engine crankshaft by hand several times, then install spark plug and tighten to 20 ft-lb (27 N·m).
13. Adjust tires to rated capacities. **See General Information, Section 8, Page 8-1.**
14. Lubricate front suspension and do all other semiannual periodic lubrication. **See Periodic Lubrication Schedule, Section 10, Page 10-2.**
15. Thoroughly clean body, seats, cargo bed, engine compartment and underside of vehicle.
16. Do not engage the park brake. Chock the wheels to prevent the vehicle from rolling.

TO RETURN VEHICLE TO SERVICE

1. Make sure the key switch is OFF and the Forward/Reverse handle is in NEUTRAL. Remove the key. Chock the wheels.
2. Remove plug from vent tube and connect to tank vent (**Figure 3-3, Page 3-3 or Figure 3-4, Page 3-3**).

3. Connect battery cables, positive (+) cable first, and tighten terminals to 20 ft-lb (27 N·m). Coat terminals with Battery Terminal Protector Spray (CC 1014305).
4. Connect the spark plug wire.
5. Completely open fuel shut-off valve (**Figure 3-5, Page 3-3**). A partially closed fuel valve (**Figure 3-7, Page 3-4**) combined with the use of the choke, can result in a fouled spark plug and engine failure.
6. Crank the engine until the engine starts. Turn the engine off. **See following NOTE.**

NOTE: Due to the oil added to the engine in preparation for storage, engine may smoke excessively for a short while when running it for the first time after storage.

7. Adjust tires to recommended tire pressure. **See General Information, Section 8, Page 8-1.**

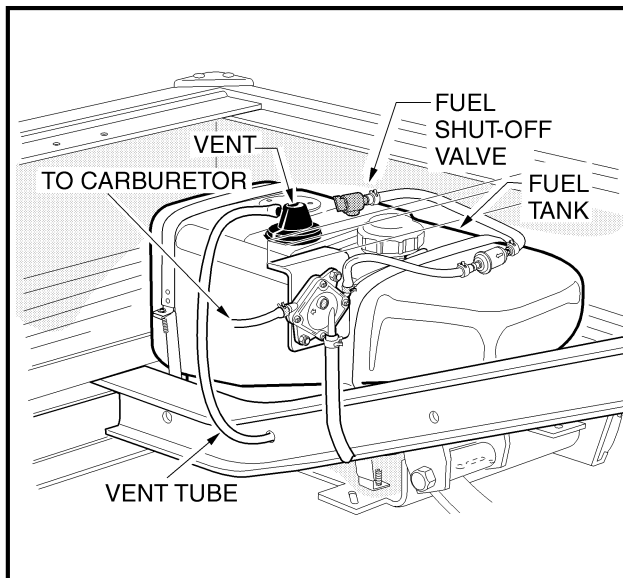

Figure 3-3 2100 Fuel Tank

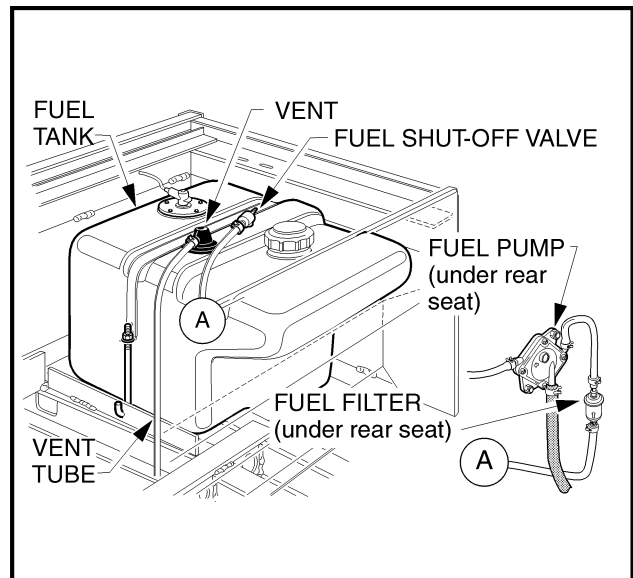

Figure 3-4 2100S Fuel Tank

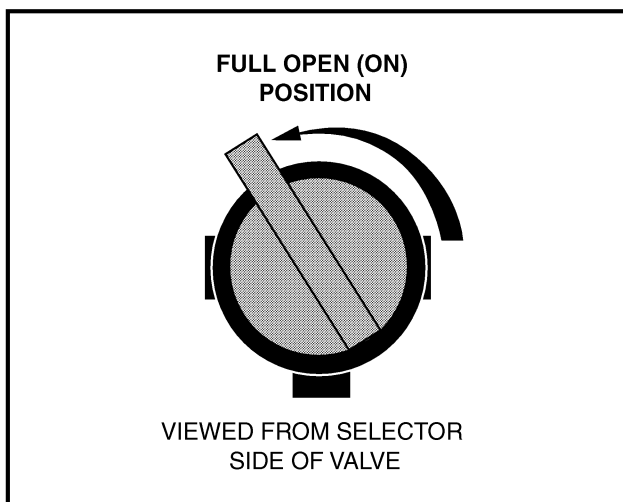

Figure 3-5 Fuel Valve – Open

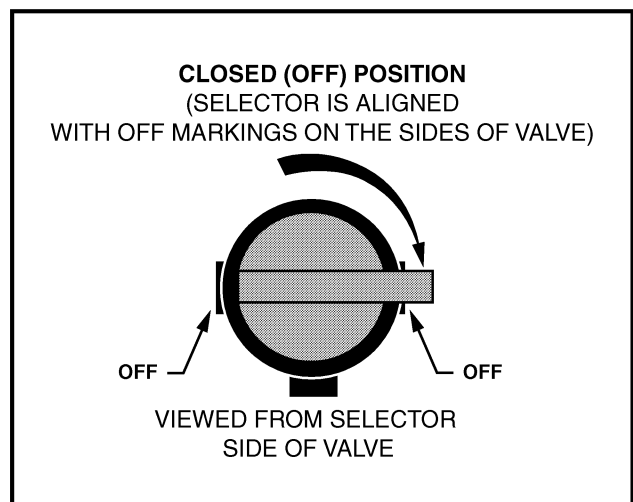

Figure 3-6 Fuel Valve – Closed

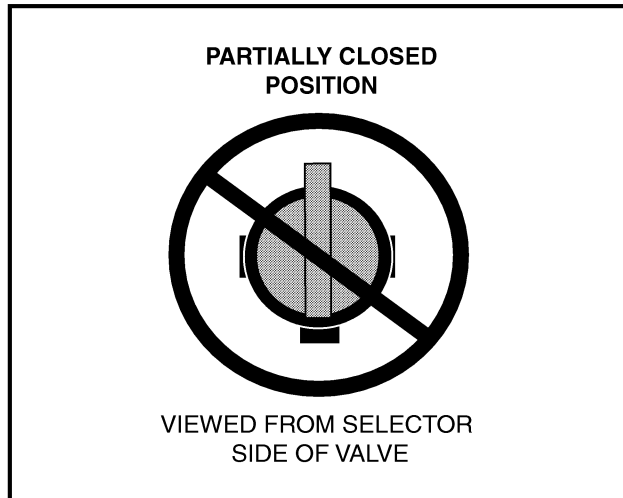

Figure 3-7 Fuel Valve – Partially Closed

SECTION 4 – BODY AND TRIM

⚠ DANGER

- See General Warning, Section 1, Page 1-1.

⚠ WARNING

- See General Warning, Section 1, Page 1-1.

⚠ CAUTION

- Do not use detergents or cleaning solvents that contain ammonia, aromatic solvents, or alkali materials on body panels or seats.
- Do not allow battery acid to drip on body panels. Battery acid will cause permanent damage. Wash spilled battery acid from body panels immediately.

CLEANING THE VEHICLE

See General Warning, Section 1, Page 1-1.

Each vehicle is equipped with an ABS/DR acrylic cap front body and an aluminum rear body and frame. The cargo bed on the Bobcat 2100 is powder-coated steel. The Bobcat 2100S has an aluminum cargo bed.

For regular front body cleaning, use automotive cleaning solutions with a sponge or soft cloth, or use Bobcat's Vehicle Care Kit (CC AM10021). Repair kits and cleaning/polishing products are also available at most hardware stores where ABS/DR acrylic (hot tubs and shower/tub units) are sold.

To remove oxidation or discoloration from aluminum, use a commercially available aluminum cleaner paste and fine grade (No. 00) steel wool. Battery acid, fertilizers, tars, asphalt, creosote, paint, or chewing gum should be removed immediately to prevent possible stains.

Bobcat does not recommend any type of pressure washing or steam cleaning. Both can create water damage to electrical components and subsequent component failure. Normal residential water pressure is adequate for exterior cleaning.

For seats, use a solution of 10% liquid soap and warm water applied with a soft cloth. For embedded dirt, a soft bristle brush may be used. For heavy soiling, difficult stains, or scratches, blemishes, or other body damage, see Seat on page 4-4. **See following NOTE.**

***NOTE:** Dispose of waste water properly.*

FRONT BODY REPAIR

See General Warning, Section 1, Page 1-1.

ABRASIONS AND HAZE

The original gloss can be restored by hand buffing with "Novus Plastic Polish", "Mirror Glaze Professional Formula Number 17", Bobcat's Vehicle Care Kit (CC AM10021), or similar polishing compounds. A buffing wheel with a small amount of automotive type paste wax applied to the pad may also be used. Use a very light touch, because ABS/DR acrylic polishes easily. Johnson's® "J-Wax" or "Kit" may be applied as a final treatment.

LIGHT SCRATCHES

Ajax cleanser applied dry and hand-rubbed will rapidly smooth moderate scratches. Use a soft polishing compound to restore gloss.

Scratches (up to 10 mils; the equivalent thickness of an average business card) can be removed by light sanding. Start with wet silicone carbide abrasive paper (320 grit or finer). Use progressively finer grits (i.e. 400, 600, 800) to reduce sanding marks. Use Ajax cleanser (or equivalent) for final smoothing. A "Micro Mesh" acrylic polishing kit with abrasive papers from 1800 to 8000 grit will provide the best final finish. Restore gloss with soft polishing compound, or Bobcat's Vehicle Care Kit (CC AM10021). It is not the intent of any of these processes to 'fill-in' the material removed due to light scratches but rather to blend the finish of the surrounding area and the scratch together.

LARGE SCRATCHES AND ABRASIONS

Touch-up is not recommended. Replace the entire body part or have it repaired by a professional paint and body repair shop with experience repairing ABS/DR acrylic bodies.

FRONT BODY COMPONENTS

See General Warning, Section 1, Page 1-1.

DASHBOARD REMOVAL

1. Make sure the key switch is OFF and the Forward/Reverse handle is in NEUTRAL. Remove the key. Chock the wheels.
2. Disconnect the battery cables as instructed. **See WARNING "To avoid unintentionally starting..." in General Warning, Section 1, Page 1-2.**
3. Remove the dash panel.
 - 3.1. Loosen the seven Tuflok[®] screws shown in Detail A (**Figure 4-1, Page 4-3**).
 - 3.2. Remove Tuflok screws from dash panel shown in Detail B.
 - 3.3. Pull forward on top of the dash panel to access back of the panel.
4. Disconnect the wiring from components mounted in the dash panel.
5. Remove five caps (1) from top of dashboard (2) (**Figure 4-2, Page 4-5**).
6. Remove screws (3) and special plastic washers (4) from top of dashboard (2) using a Torx #T-30 driver.
7. Remove five screws (5) from underside of dashboard and pull dashboard away from front body (6).
8. Remove the steering wheel. **See Steering Wheel Removal, Section 7, Page 7-1.**
9. Remove dashboard from vehicle.

DASHBOARD INSTALLATION

1. Reverse the dashboard removal process.
2. Tighten screws (5) to 11 in-lb (1.2 N·m) (**Figure 4-2, Page 4-5**).
3. Tighten Torx-head screws (3) with plastic washers (4) to 45 in-lb (5.1 N·m).
4. Install five caps (1).
5. Install the dash panel and connect wiring to panel components.
6. Install steering wheel. **See Steering Wheel Installation, Section 7, Page 7-3.**

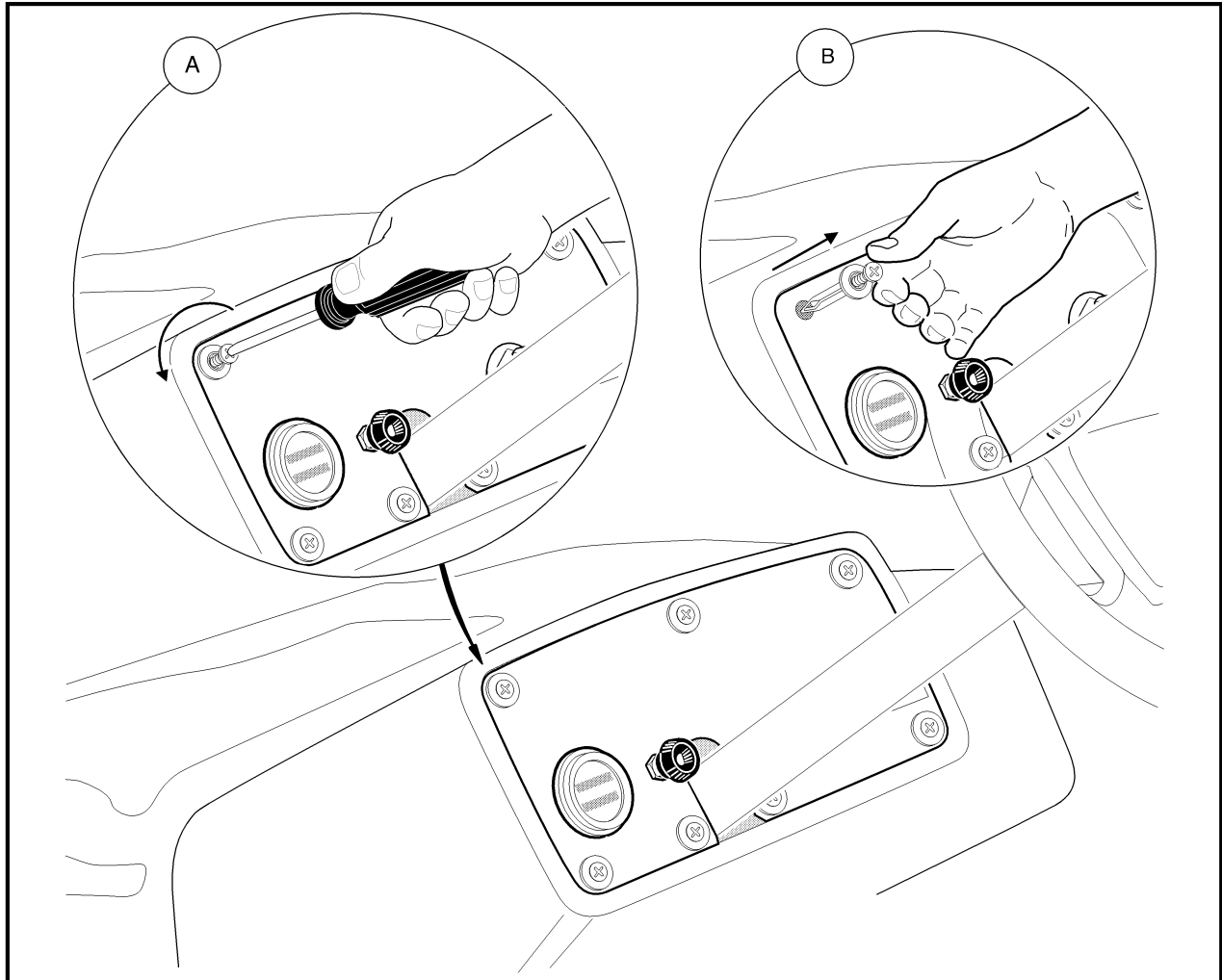

Figure 4-1 Dash Panel Removal

FRONT BODY REMOVAL

1. Remove five caps (1) from top of dashboard (2) (**Figure 4-2, Page 4-5**).
2. Use a Torx #T-30 driver to remove the Torx-head screws (3) and washers (4) from top of front body (6).
3. Use a 5/16 nut driver to remove five screws (5) from underside of dashboard (2) and gently slide dashboard away from front body (6).
4. Use a phillips head screwdriver to remove the six Tuflok fasteners (7) from sides and two (7) from front of body (6).
5. Disconnect light wiring harness from each headlight assembly.
6. Lift the back edge of the body up and pull forward to remove from vehicle.

FRONT FENDER REMOVAL

1. Remove front body (6) (**Figure 4-2, Page 4-5**). See **Front Body Removal** on page 4-3.
2. Pull back floor mat to access rivets securing front fender (9) to frame. Drill out two 3/16 x 5/8 pop rivets (10) and remove two washers (11).
3. Use a 3/8 hex-head socket to remove two screws (12) from fender frame support and remove fender.

FRONT FENDER INSTALLATION

1. Reverse the fender removal process (**Figure 4-2, Page 4-5**).
2. Tighten screws (12) to 50 in-lb (5.7 N·m).
3. Pop rivet fender to frame using two 3/16 x 5/8 pop rivets (10) and two 3/16 rivet washers (11).
4. Install front body. **See Front Body Installation on page 4-4.**

FRONT BODY INSTALLATION

1. Reverse the front body removal process (**Figure 4-2, Page 4-5**).
2. Secure front body to dashboard with screws (3) and plastic washers (4) and tighten to 45 in-lb (5.1 N·m).
3. Install five caps (1).
4. Secure front body to fenders with fasteners (7) and push the heads in until they snap into place.

SEAT

See General Warning, Section 1, Page 1-1.

Clean seats regularly using the following guidelines: **See following CAUTION.**

CAUTION

- **To prevent damage to the vehicle when removing difficult stains or heavy soiling, remove the seat from the vehicle first.**

Light Soiling – A solution of 10% liquid dish soap and warm water applied with a soft, damp cloth is recommended. A soft bristle brush may be used if necessary. Wipe off any residue with a water dampened cloth.

Difficult Stains – Dampen a soft, white cloth with a solution of 10% household bleach (sodium hypochlorite) and 90% water. Rub gently to remove stain, then rinse with a water dampened cloth to remove bleach concentration. Use Bobcat's Vehicle Care Kit (CC AM10021) to recondition the fabric.

For More Difficult Stains – Perform previous procedure using full-strength bleach, or allow bleach to puddle on affected area for approximately 30 minutes. Rinse with a water dampened cloth to remove any remaining bleach concentration. Use Bobcat's Vehicle Care Kit (CC AM10021) to recondition the fabric.

SEAT ADJUSTMENT

1. Remove seat (2) from vehicle.
2. Disassemble seat (2) from seat panel (3) by removing four bolts (4) and lock washers (5) (**Figure 4-3, Page 4-6**).
3. Adjust seat to preferred position. Align holes in seat panel (3) with holes in seat (2) and secure with four bolts (4) and lock washers (5). Tighten bolts to 96 in-lb (10.8 N·m).

⚠ WARNING

- **Make sure seat hinges and latch are securely engaged before operating vehicle.**

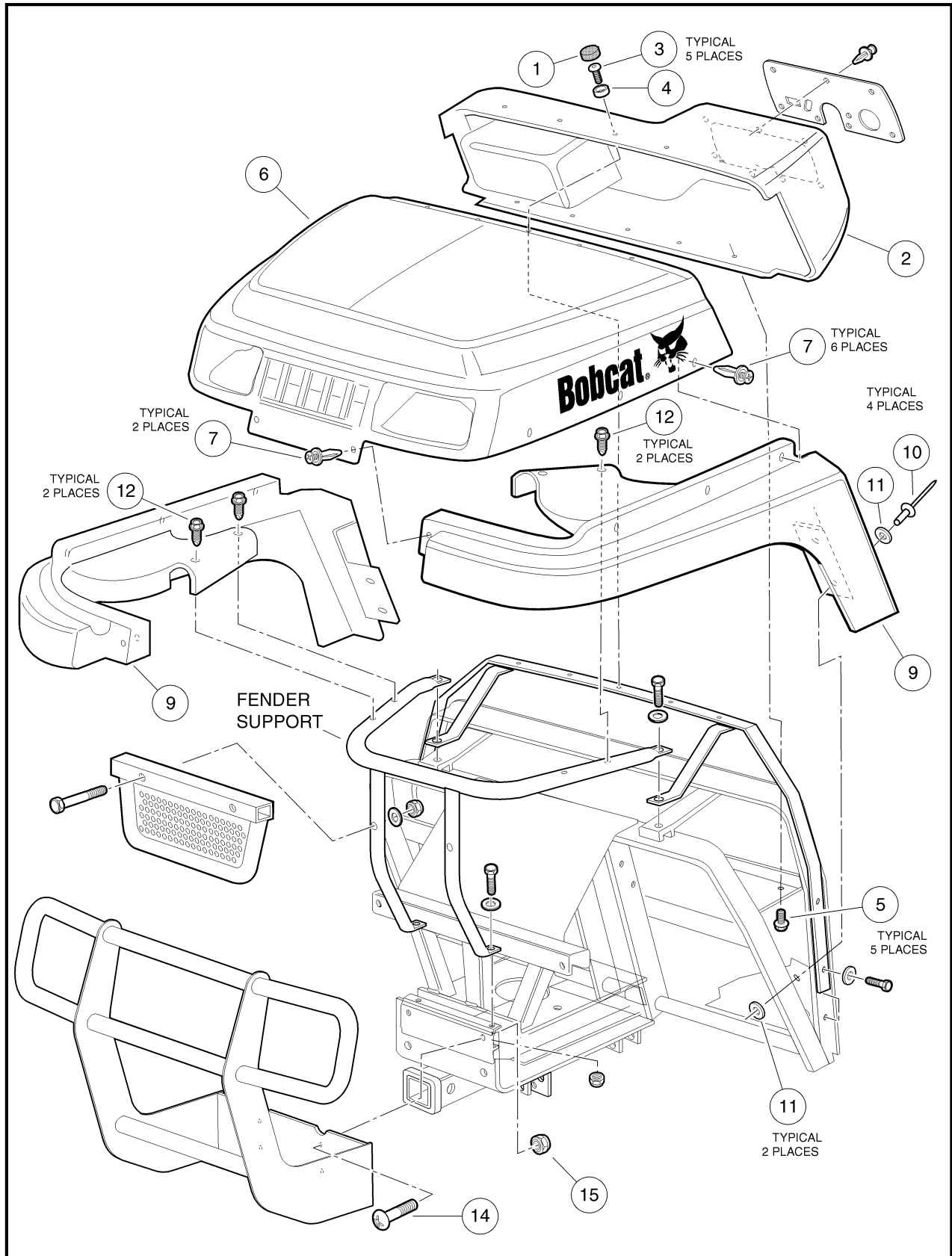

Figure 4-2 Front Body Assembly

FRONT SEAT SUPPORT

See General Warning, Section 1, Page 1-1.

FRONT SEAT SUPPORT REMOVAL

1. Completely remove both front seats (2) from the vehicle (**Figure 4-3, Page 4-6**).
2. Remove park brake equalizer cable from park brake handle. **See Equalizer Cable Removal, Section 6, Page 6-33.**
3. Disconnect cable from differential lock control. **See step 5 in Unitized Transaxle Removal, Section 16, Page 16-6.**

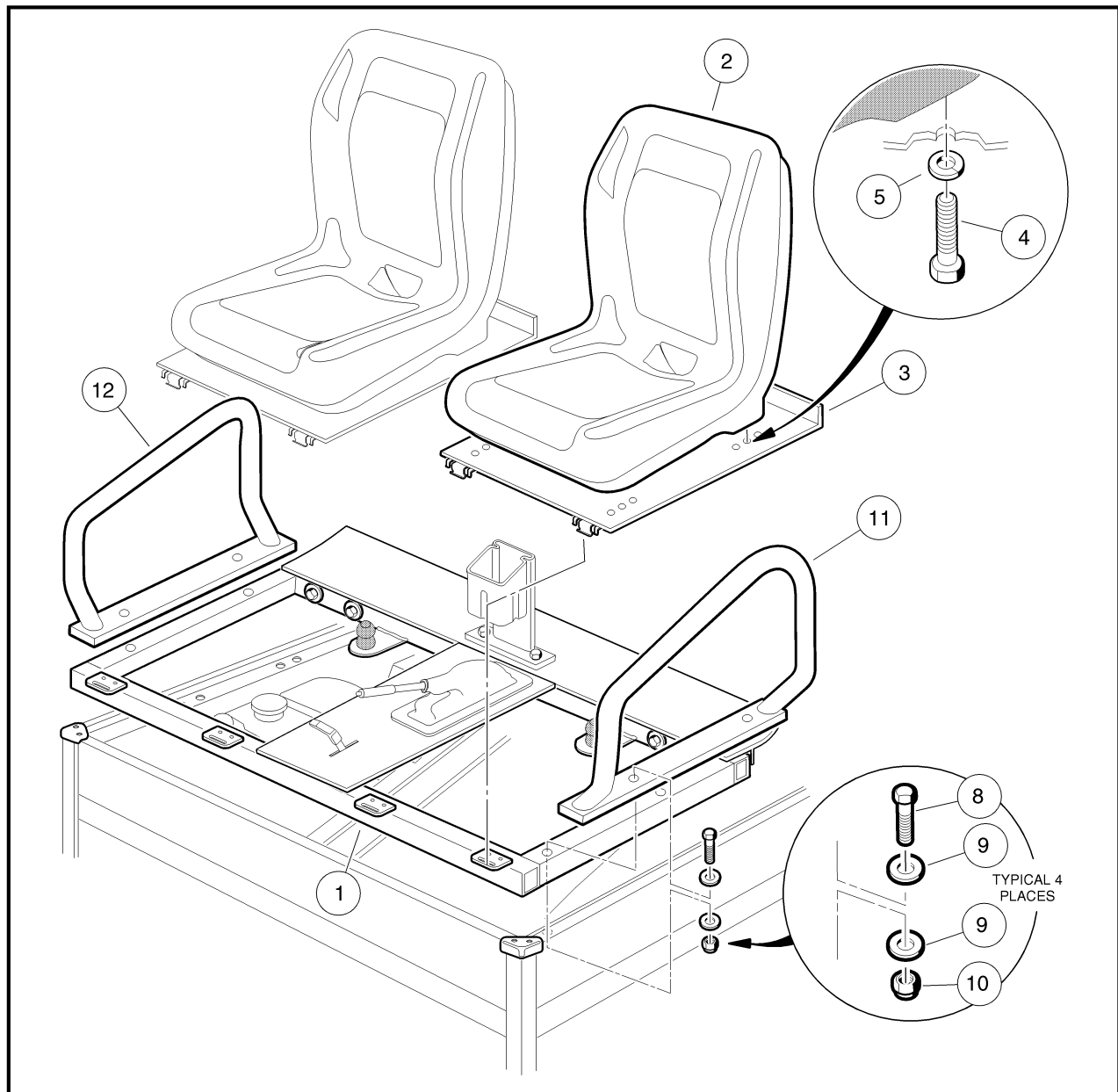

Figure 4-3 Front Seat Support

4. Remove four hex-head bolts (8), eight washers (9) and four lock nuts (10) from the seat support (**Figure 4-3, Page 4-6**).
5. Remove the two armrests (11 and 12) from the seat support (1).
6. Lift seat support (1) from vehicle.

FRONT SEAT SUPPORT INSTALLATION

1. Reverse the front seat support removal process (**Figure 4-3, Page 4-6**).
2. Assemble bolts (8), washers (9), and lock nuts (10) to seat support and armrests (11 and 12) and tighten bolts (8) to 13 ft-lb (17.6 N·m). **See following WARNING.**

⚠ WARNING

- **Both armrests must be installed before operating the vehicle, unless the vehicle is fitted with a structural cab.**
3. Connect differential lock cable to differential lock handle. **See step 33 of Unitized Transaxle Installation, Section 16, Page 16-22.**
 4. Install park brake equalizer cable. **See Equalizer Cable Installation, Section 6, Page 6-34.**
 5. Install both front seats (2) onto the vehicle.

REAR SEAT SUPPORT

See General Warning, Section 1, Page 1-1.

REAR SEAT SUPPORT REMOVAL

1. Lift rear seat cushion and remove from the vehicle.
2. Remove eight 1/4-20 flange lock nuts (21) and eight 1/4-20 x 3/4-inch carriage bolts (20) and remove armrests (10 and 11) (**Figure 4-4, Page 4-8**).
3. Remove four 1/4-20 x 1 inch, phillips drive, truss-head machine screws (19) and lock washers (18) from seat back support (22) and remove seat back (16) and seat back cap (17).
4. Remove four 5/16-18 flange lock nuts (24) and four 5/16-18 x 3/4-inch carriage bolts (23) and remove seat back support (22).
5. Remove seat bottom rear trim (13) by pushing-out, from the back of the seat back support (22), five plastic barrel connectors (12).
6. Remove the seat bottom front trim (14) by lifting the lower inside flange slightly across the entire seat area. Push the trim toward the rear of the vehicle, allowing the top flange to slide away from the seat frame toward the rear of the vehicle.

REAR SEAT SUPPORT INSTALLATION

1. Slide the seat bottom front trim toward the front edge of the seat frame with the top flange of the trim sliding over the top of the frame. Push toward the front of the vehicle until the lower flange snaps into place. The top and bottom flanges of the trim should be in direct contact with the frame structure.
2. Install the seat back support (22) in reverse order of removal. Tighten hardware to 15 ft-lb (20.34 N·m).
3. Install a new seat bottom rear trim using new barrel connectors.

Rear Seat Support Installation, Continued:

4. Install arm rests (10 and 11) in reverse order of removal. Tighten hardware to 65 in-lb (7.345 N·m).
5. Install seat back (16) and seat back cap (17) in reverse order of removal. Tighten hardware to 6 ft-lb (8.136 N·m).
6. Install bottom bench seat, aligning the front edge of the seat against the inside edge of the front trim, and push down into place.

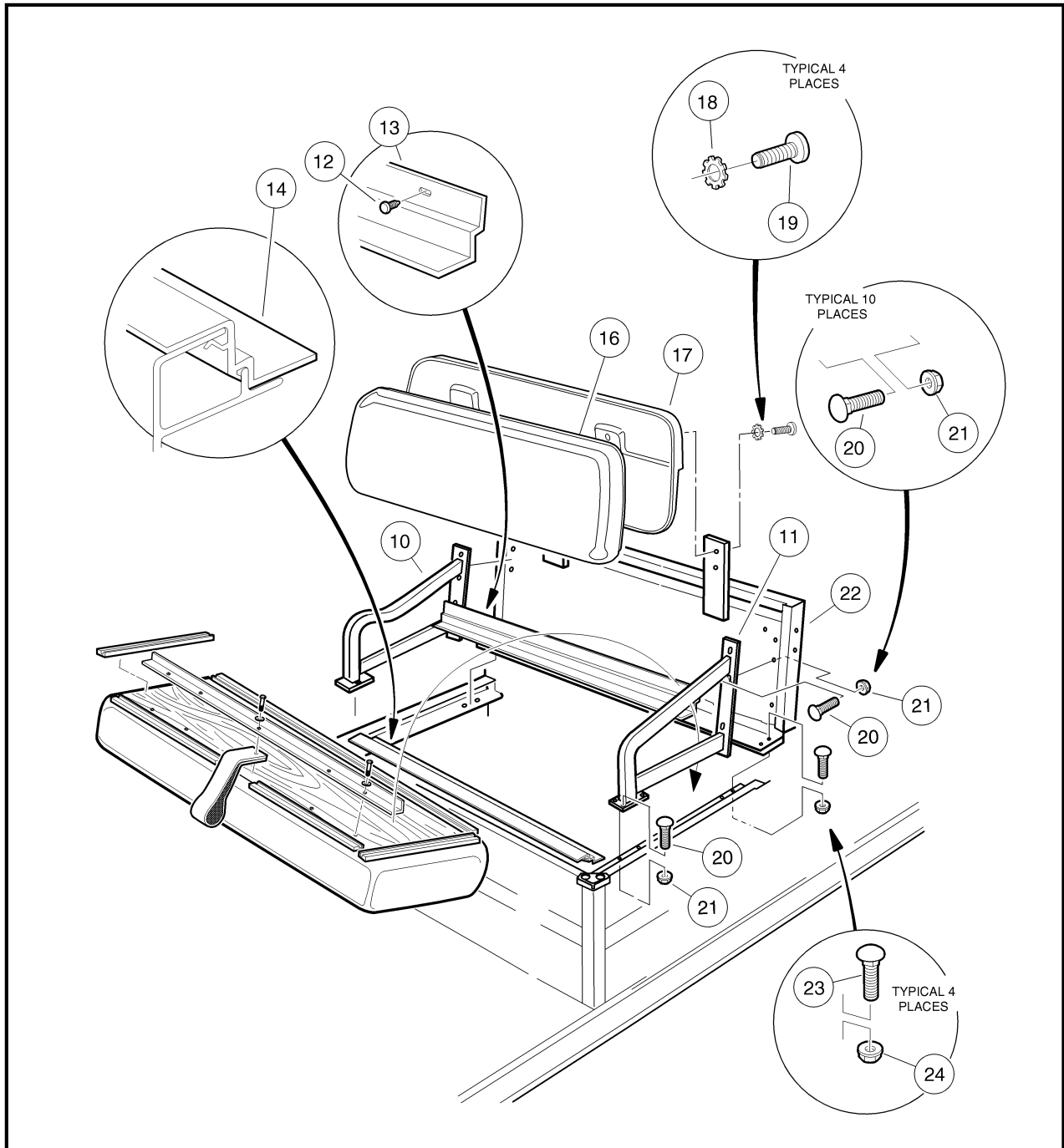
**Figure 4-4 Bobcat 2100S Rear Seat Support**



Suggest:

If the above button click is invalid.

Please download this document

first, and then click the above link

to download the complete manual.

Thank you so much for reading

CARGO BED

See General Warning, Section 1, Page 1-1.

CARGO BED REMOVAL

NOTE: The following procedures will be easier with the help of an additional person.

1. Bobcat 2100:

Prop rods (1) (CC 1015348) and (25) (CC 102301401) are not interchangeable (**Figure 4-5, Page 4-10**).

- 1.1. Raise bed and ensure that the prop rod (1) or (25) is secured in the prop rod track (2). Hold bed securely in an upright position. Remove cotter pin (3) and flat washer (4) from top end of prop rod where prop rod attaches to bed. Remove prop rod (1) or (25) from bed and place prop rod between prop rod track (2) and rear body panel. Lower bed onto vehicle frame (**Figure 4-5, Page 4-10**).
- 1.2. Remove two 3/8-16 nylon lock nuts (8) from left and right cargo bed hinge/bolt assemblies.
- 1.3. Apply slight upward pressure (by hand) on the rear of the bed to relieve pressure on the hinges, and remove the 3/8 x 3-3/8-inch hinge bolts (9) from the hinge assemblies.
- 1.4. Raise rear edge of bed approximately 6 inches (15.2 cm) and pull bed assembly toward rear of vehicle (approximately 3 inches (7.6 cm)) to release bed latch assembly (10) from latch plate (11) and lift bed from vehicle.

2. Bobcat 2100S:

- 2.1. Remove two 3/8-16 nylon lock nuts (2) from left and right cargo bed hinge/bolt assemblies (**Figure 4-6, Page 4-11**).
- 2.2. Apply slight upward pressure (by hand) on the rear of the bed to relieve pressure on the hinges, and remove the 3/8 x 3-3/8-inch hinge bolts (1) from the hinge assemblies.
- 2.3. Raise rear edge of bed approximately 6 inches (15.2 cm) and pull bed assembly toward rear of vehicle (approximately 3 inches (7.6 cm)) to release bed latch assembly (6) from latch plate (11) and lift bed from vehicle.

CARGO BED INSTALLATION

NOTE: The following procedure will be easier with the help of an additional person.

1. Bobcat 2100:

- 1.1. Hold front of bed lower than rear of bed and place front edge of bed onto vehicle frame and align latches (10) with latch plates (11) (**Figure 4-5, Page 4-10**).
- 1.2. Lower rear edge of bed onto vehicle and align frame hinge brackets (14) with bed hinge brackets (15).
- 1.3. Start the bolts (9) into left and right hinge assemblies. Use an alignment tool if necessary.
- 1.4. Use a small hammer to lightly tap bolts through hinge assembly.
- 1.5. Install nylon lock nut (8) on each bolt (9) and tighten to 15 ft-lb (21 N·m).
- 1.6. Lift bed from bed latch and with prop rod in a slot notch, place prop rod (1) or (25) in bed mounting hole and install flat washer (4) and a new cotter pin (3) onto prop rod.
- 1.7. Proceed to Bed Stop Bumper Adjustment on page 4-11.

<https://www.ebooklibonline.com>

Hello dear friend!

Thank you very much for reading.

Enter the link into your browser.

The full manual is available for immediate download.

<https://www.ebooklibonline.com>