

1600

SERVICE MANUAL

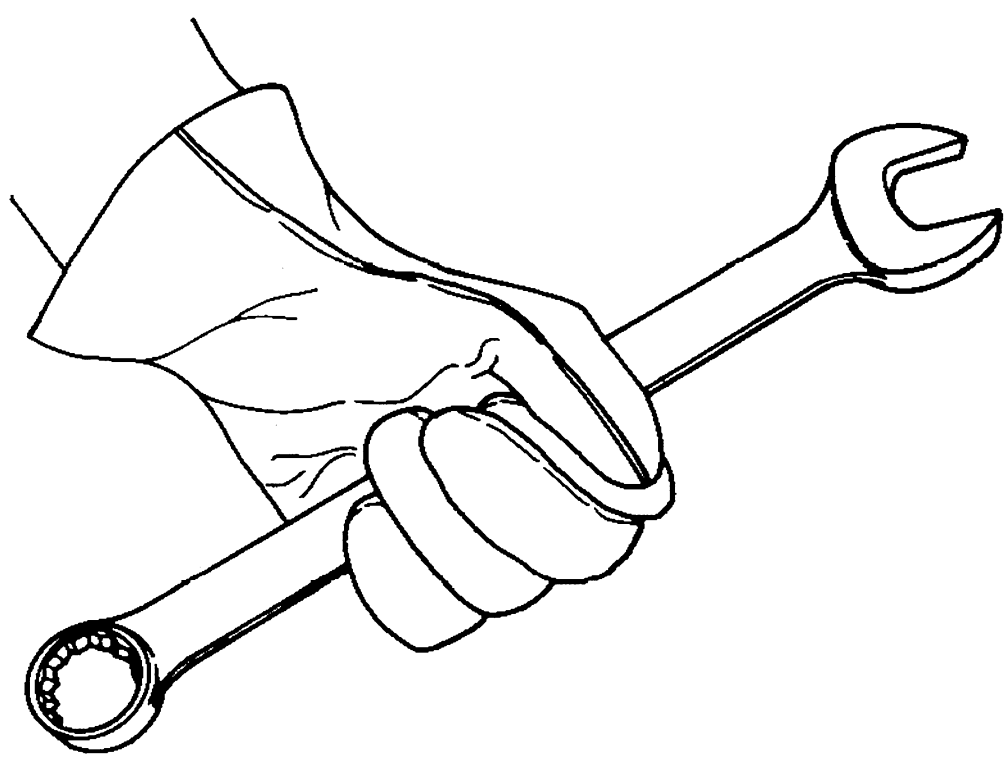

MELROE
INGERSOLL-RAND



MAINTENANCE SAFETY



WARNING

Instructions are necessary before operating or servicing machine. Read and understand the Operation & Maintenance Manual, Operator's Handbook and signs (decals) on machine. Follow warnings and instructions in the manuals when making repairs, adjustments or servicing. Check for correct function after adjustments, repairs or service. Untrained operators and failure to follow instructions can cause injury or death.

W-2003-0903



Safety Alert Symbol: This symbol with a warning statement, means: "Warning, be alert! Your safety is involved!" Carefully read the message that follows.

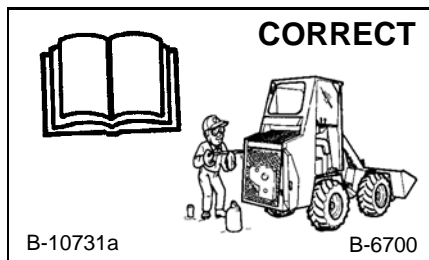

⚠ Never service the Bobcat Loader without instructions. See Service Manual.

⚠ Check engine and hydraulic fluids daily.

⚠ Use recommended fluids.

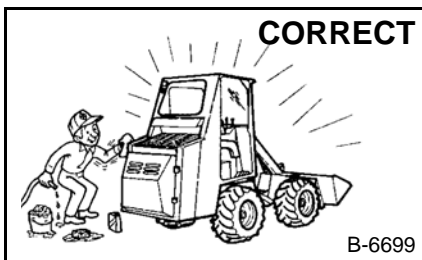

⚠ Cleaning and maintenance are required daily.

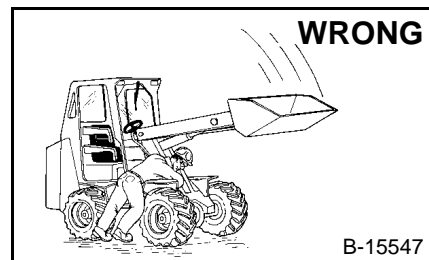

⚠ Disconnecting or loosening any hydraulic tubeline, hose, fitting, component or a part failure can cause lift arms to drop. Do not go under lift arms when raised unless supported by an approved lift arm support device. Replace it if damaged.

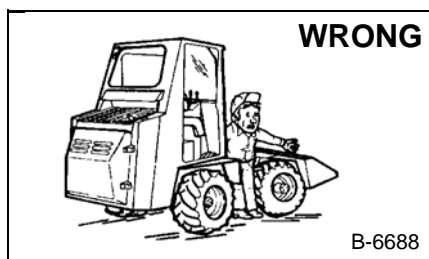

⚠ Always connect steering frame lock before working on the loader.

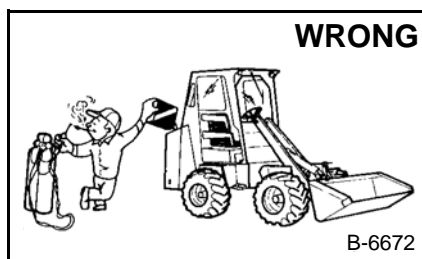

⚠ Do not fill the fuel tank with engine running, while smoking or when near an open flame.



⚠ Never work on loader with lift arms up unless lift arms are held by an approved lift arm support device.

⚠ Never modify equipment or add attachments not approved by Bobcat Company.

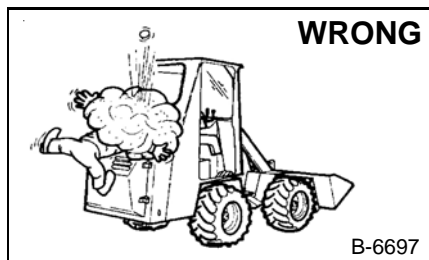

⚠ Stop, cool and clean engine of flammable materials before checking fluids.

⚠ Never service or adjust loader with the engine running unless instructed to do so in the manual.

⚠ Avoid contact with leaking hydraulic fluid or diesel fuel under pressure. It can penetrate the skin or eyes.

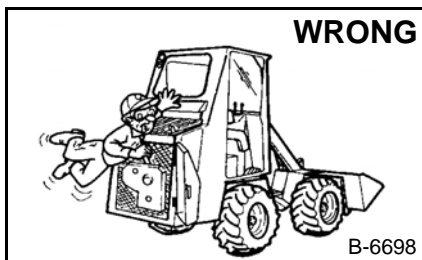

⚠ Keep body, jewelry and clothing away from moving parts, electrical contact, hot parts and exhaust.

⚠ Wear eye protection to guard from battery acid, compressed springs, fluids under pressure and flying debris when engines are running or tools are used. Use eye protection approved for type of welding.

⚠ Keep rear door closed except for service. Close and latch door before operating the loader.

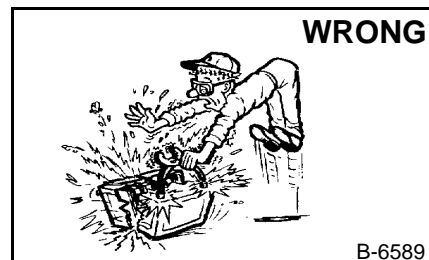

⚠ Lead-acid batteries produce flammable and explosive gases.

⚠ Keep arcs, sparks, flames and lighted tobacco away from batteries.

⚠ Batteries contain acid which burns eyes or skin on contact. Wear protective clothing. If acid contacts body, flush well with water. For eye contact flush well and get immediate medical attention.

Maintenance procedures which are given in the Operation & Maintenance Manual can be performed by the owner/operator without any specific technical training. Maintenance procedures which are **not** in the Operation & Maintenance Manual must be performed **ONLY BY QUALIFIED BOBCAT SERVICE PERSONNEL**. Always use genuine Bobcat replacement parts. The Service Safety Training Course is available from your Bobcat dealer.

MSW04-0805

FOREWORD

This manual is for the Bobcat loader mechanic. It provides necessary servicing and adjustment procedures for the Bobcat loader and its component parts and systems. Refer to the Operation & Maintenance Manual for operating instructions, starting procedure, daily checks, etc.

A general inspection of the following items must be made after the loader has had service or repair:

1. Check that the ROPS/FOPS is in good condition and is not modified.

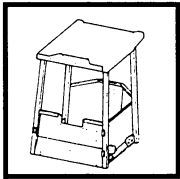

2. Check that ROPS mounting hardware is tightened and is Melroe approved.

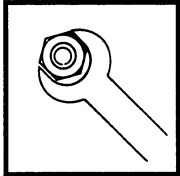

3. The seat belt must be correctly installed, functional and in good condition.

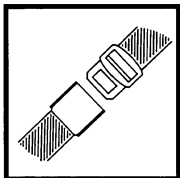

4. The operator restraint arm must function correctly.

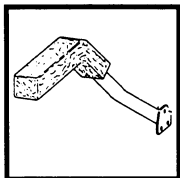

5. Machine signs must be legible and in the correct location.

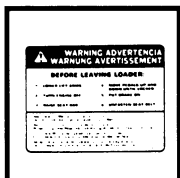

6. Foot pedal must return to neutral.

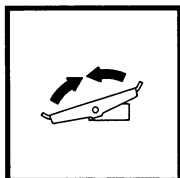

7. Check for correct function of the work lights.



8. The parking brake must function correctly.

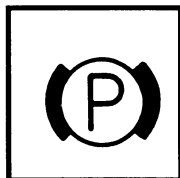

9. Enclosure door latches must open and close freely.

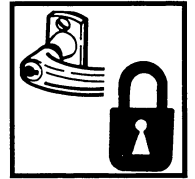

10. Bob-Tach wedges and linkages must function correctly and be in good condition.

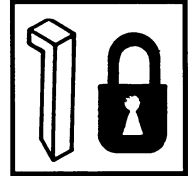

11. Safety treads must be in good condition.

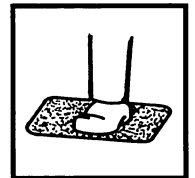

12. Check for correct function of indicator lamps.

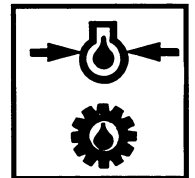

13. Check hydraulic fluid level, engine oil level and fuel supply.

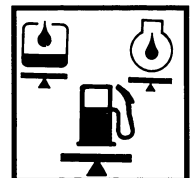

14. Inspect for fuel, oil or hydraulic fluid leaks.

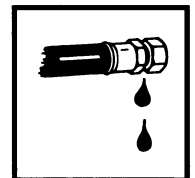

15. Lubricate the loader.



16. Check the condition of the battery and cables.

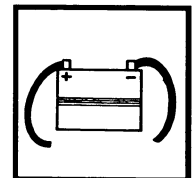

<https://www.ebooklibonline.com>

Hello dear friend!

Thank you very much for reading.

Enter the link into your browser.

The full manual is available for immediate download.

<https://www.ebooklibonline.com>

17. Inspect the air cleaner for damage or leaks. Check the condition of the element.

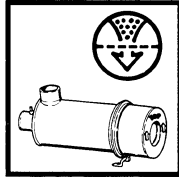

18. Check the electrical charging system.

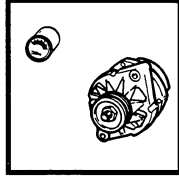

19. Check tires for wear and pressure.

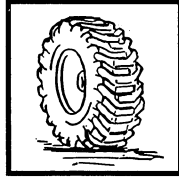

20. Inspect for loose or broken parts or connections.

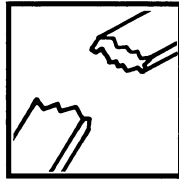

Recommend to the owner that all necessary corrections be made before the machine is returned to service.

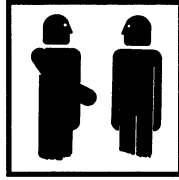

CONTENTS

SAFETY INSTRUCTIONS.....	i
SERIAL NUMBER LOCATIONS.....	ii
DELIVERY REPORT.....	ii
BOBCAT ARTICULATED LOADER IDENTIFICATION.....	iii
PREVENTIVE MAINTENANCE.....	1-1
HYDRAULIC SYSTEM.....	2-1
HYDROSTATIC SYSTEM.....	3-1
DRIVE SYSTEM.....	4-1
MAIN FRAME.....	5-1
ELECTRICAL SYSTEM.....	6-1
ENGINE SERVICE.....	7-1
TECHNICAL DATA.....	8-1

**PREVENTIVE
MAINTENANCE**

**HYDRAULIC
SYSTEM**

**HYDROSTATIC
SYSTEM**

**DRIVE
SYSTEM**

**MAIN
FRAME**

**ELECTRICAL
SYSTEM**

**ENGINE
SERVICE**

**TECHNICAL
DATA**

SAFETY INSTRUCTIONS

WARNING

Instructions are necessary before operating or servicing machine. Read Operation & Maintenance Manual, Handbook and signs (decals) on machine. Follow warnings and instructions in the manuals when making repairs, adjustments or servicing. Check for correct function after adjustments, repairs or service. Failure to follow instructions can cause injury or death.

W-2003-1289

The following publications provide information on the safe use of the loader and attachments:

1. The Delivery Report is used to assure that complete instructions have been given to the new owner and that the machine is in safe operating condition.
2. The Operation & Maintenance Manual delivered with the loader gives operating information as well as routine maintenance and service procedures. It is a part of the loader and must stay with the machine when it is sold.
3. The loader has machine signs (decals) which instruct on the safe care and operation. The signs and their locations are shown in the Operation & Maintenance Manual. Replacement signs are available from Bobcat loader dealers.
4. The FIEI Manual delivered with the loader gives general safety information.
5. The Service Manual and Parts Manual are available from Bobcat loader dealers for use by mechanics to do shop-type service and repair work.



Safety Alert Symbol: This Safety Symbol is used for important safety messages. When you see this symbol follow the safety message to avoid personal injury or death.

- Wear tight fitting clothing and any other required safety apparel when operating or servicing the loader.
- Wear safety glasses when maintaining or servicing the loader.
- Exhaust gases can kill, vent engine exhaust outdoors.
- Know where fire extinguishers and first aid kits are located and how to use them.
- Do not run the Bobcat loader where exhaust, arcs, sparks or hot components can contact flammable material, explosive dust or gases.
- Check fuel and hydraulic tubes, hoses and fittings for damage and leakage. Never use open flame or bare skin to check for leaks. Tighten or replace any parts that show leakage. Always clean fluid spills. Do not use gasoline or diesel fuel for cleaning parts. Use commercial nonflammable solvents.
- Clean the loader before doing any welding. Cover rubber hoses, battery and all other flammable parts. Keep a fire extinguisher near the loader when welding.
- Have good ventilation when welding or grinding painted parts. Wear a dust mask when grinding painted parts. Toxic dust and gas can be produced.
- Stop the engine and let it cool before adding fuel. No smoking!
- Use the procedure in this manual for connecting battery.
- Use the procedure in this manual for cleaning the spark arrestor muffler after each 100 hours of operation.

SERIAL NUMBER LOCATIONS

Always use the serial number of the loader when requesting service information or when ordering parts. Early or later models (identification made by serial number) may use different parts, or it may be necessary to use a different procedure in doing a specific service operation.

LOADER SERIAL NUMBER

The loader serial number plate is located on the inside of the left upright, above the grill [A].

Explanation of loader Serial Number:

XXXX XXXXX

Module 2. – Production Sequence (Series)

Module 1. – Model/Engine Combination

1. The four digit Model/Engine Combination Module number identifies the model number and engine combination. This number (in parenthesis beside the model number) is used in the Operation & Maintenance Manual to more easily identify the standard, optional and field accessory equipment included or available for each specific model.
2. The five digit Production Sequence Number identifies the order which the loader is produced.

ENGINE SERIAL NUMBER

The serial number is above the starter on the engine block [B].

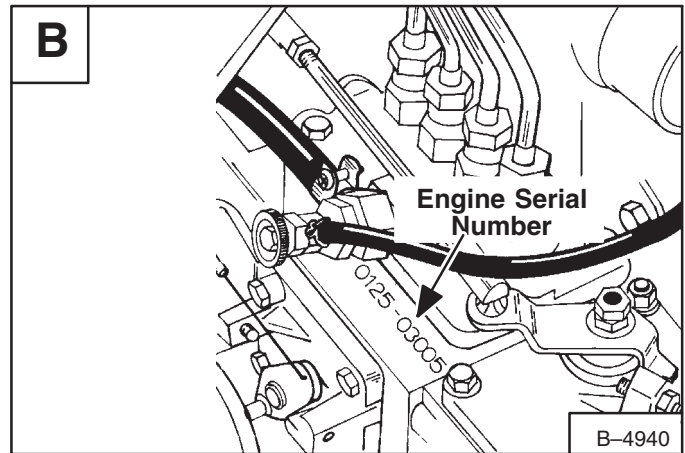
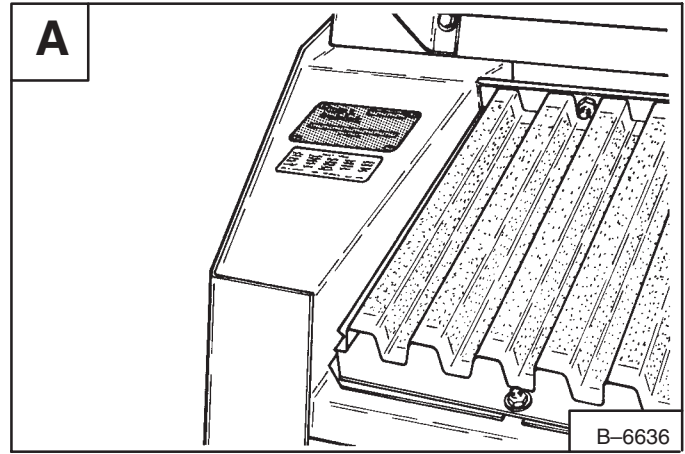

DELIVERY REPORT

The Delivery Report must be filled out by the dealer and signed by the owner or operator when the Bobcat loader is delivered. An explanation of the form must be given to the owner. Make sure it is filled out completely [C].

Diagram D shows a form titled 'DELIVERY REPORT'. The form is divided into several sections. At the top right, there is a section labeled 'DELIVERY REPORT' with several lines for text. Below this, there is a section labeled 'WARNING' with several lines for text. The form is labeled 'D' in the top left corner.

BOBCAT LOADER IDENTIFICATION

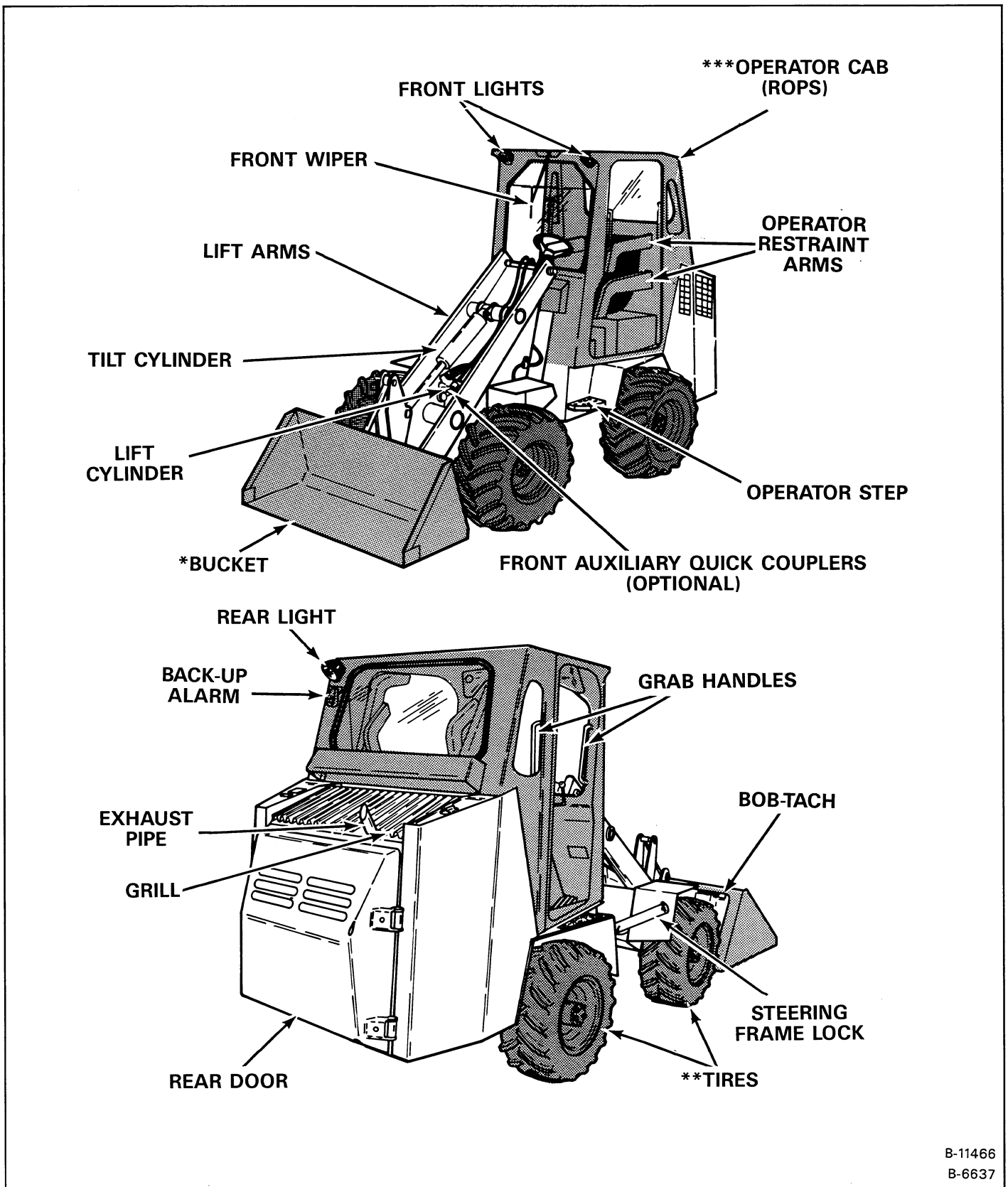

B-11466
B-6637

* BUCKET — Several different buckets and other attachments are available for the Bobcat loader.

** TIRES — Tires shown are optional flotation tires which are not standard for this loader.

*** ROPS — Roll Over Protective Structure.

PREVENTIVE MAINTENANCE



	Page Number
FRAME LOCK	
Procedure	1-3
LIFT ARM SUPPORT DEVICE	
Procedure	1-3
LIFTING AND BLOCK THE LOADER	
Procedure	1-2
OPERATOR RESTRAINT SYSTEM	
Description	1-5
Inspection of the Operator Restraint System	1-5
Servicing the Operator Restraint System	1-5
SERVICE SCHEDULE	
Chart	1-1
TRANSPORTING THE LOADER	
Procedure	1-4
USING AN EXTRA BATTERY (JUMP STARTING)	
Procedure	1-6

SERVICE SCHEDULE

You must do maintenance work at regular intervals. Failure to do so will result in damage to the loader or the engine. The service schedule is a guide for correct maintenance of the Bobcat loader. Follow this service schedule as explained below unless it is to increase the frequency of intervals when the Bobcat is used in very hot, cold, dusty or corrosion conditions.

 WARNING	<p>Instructions are necessary before operating or servicing machine. Read Operator's Manual, Handbook and signs (decals) on machine. Follow warnings and instructions in the manuals when making repairs, adjustments or servicing. Check for correct function after adjustments, repairs or service. Failure to follow instructions can cause injury or death.</p>	<p>W-2003-1285</p>
--	---	--------------------

SERVICE SCHEDULE		HOURS				
ITEM	SERVICE REQUIRED	8-10	50	100	250	1000
Engine Oil	Check the oil & add as needed.					
Air Cleaner Indicator	Replace the outer element when the red ring shows in the condition indicator window.					
Tires	Check tires for damage & correct pressure.					
Seat Belt & Restraint Arms	Check the condition of the seat belt & restraint arms for correct operation.					
Safety Signs (Decals)	Check for damaged decals. Replace any decals that are damaged or missing.					
Loader Pivot Points	Add lubricant to all fittings (See Operator's Manual).					
Hydraulic Fluid Reservoir	Check the fluid level & add fluid as needed.					
Engine Coolant System	Check level & add as needed. Remove any debris from the grill area.					
Wheel Nuts	* Tighten wheel nuts to 115 ft.lbs. (155 Nm) torque.					
Fuel Filter	Remove any trapped water.					
Battery & Cables	Check the battery water level & add as needed. Clean cable ends & cover with grease.					
Hyd. Control Levers	Check the levers for correct operation. Make repairs & adjust as needed.					
Bob-Tach	Check the locking levers & wedges for condition & correct operation.					
Brake	Check the brake for correct operation.					
Alternator Belt	Check condition & tension of belt.					
Engine Oil & Filter	Replace oil & filter.					
Spark Arrestor Muffler	Empty spark chamber.					
U-Joints (Drive Shaft)	Lubricate with the correct grease (See Operator's Manual).					
Hydraulic Filter	Replace the filter element.					
Fuel Filter	Replace the fuel filter element.					
Front & Rear Axle	Check oil level & add as needed.					
U-Joint (Eng. to Hydro. Pump)	Lubricate with the correct grease (See Operator's Manual).					
Hyd./Hydro. System	Replace the fluid & filter. Replace vent filter.					

* Check the wheel nuts torque every 8 hours for the first 24 hours of operation.

PREVENTIVE MAINTENANCE



WARNING

Instructions are necessary before operating or servicing machine. Read Operator's Manual, Handbook and signs (decals) on machine. Follow warnings and instructions in the manuals when making repairs, adjustments or servicing. Check for correct function after adjustments, repairs or service. Failure to follow instructions can cause injury or death.

W-2003-1285

A



B-7023

LIFTING AND BLOCKING THE BOBCAT LOADER

Procedure

Always park the loader on a level surface.



WARNING

Put jackstands under the front axles and rear corners of the frame before running the engine for service. Failure to use jackstands can allow the machine to fall or move and cause injury or death.

W-2017-0286

B

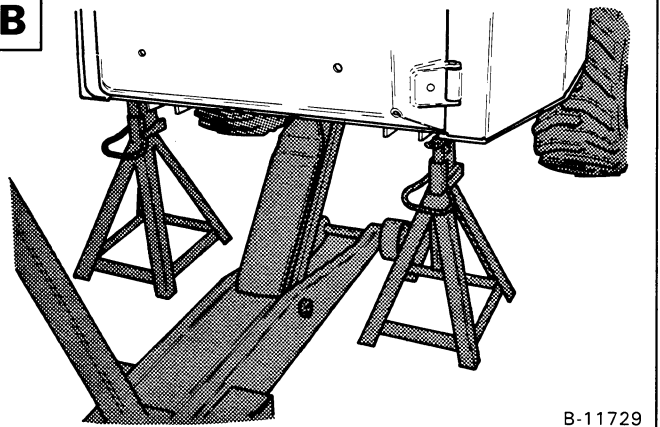

B-11729

Put the floor jack under the rear of the loader **B**.

Lift the rear of the loader and install the heavy duty jackstands **B**.

Put the floor jack under the front axle differential housing **C**.

C

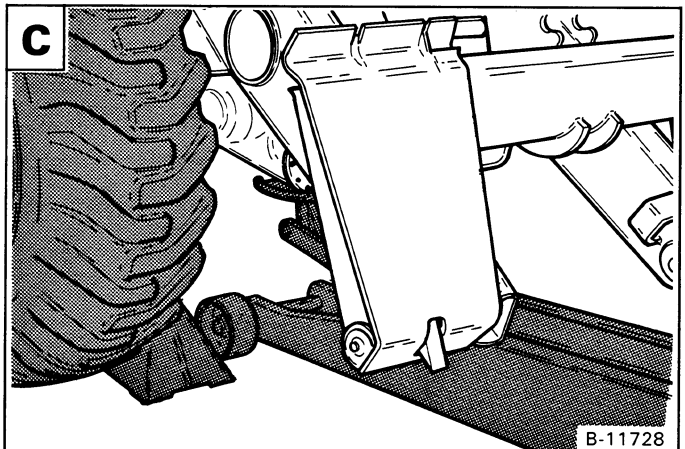

B-11728

Lift the front of the loader and put the heavy duty jackstands under the axle housing **C**.

NOTE: Make sure the jackstands do not touch the tires.

LIFT ARM SUPPORT DEVICE

Procedure



WARNING

Never work on a machine with the lift arms up unless the lift arms are secured by a lift arm support device. Failure to use an approved lift arm support device can allow the lift arms or attachment to fall.

W-2059-0991

NOTE: Lift arm support device is available from your Bobcat dealer.

One person must stay in the operator's seat, with the seat belt fastened and operator restraint system lowered, while the other person installs the lift arm support device.

Start the engine and raise the lift arms all the way up.

Have a second person install the lift arm support device over the rod of the lift cylinder **A**.

Lower the lift arms slowly until the support device is held between the lift arms and lift cylinder.

FRAME LOCK

Procedure

Before any service work is done on the Bobcat loader, always install the frame lock **B**.

Never allow anyone in or near the pivot area unless the frame lock is installed **C**.

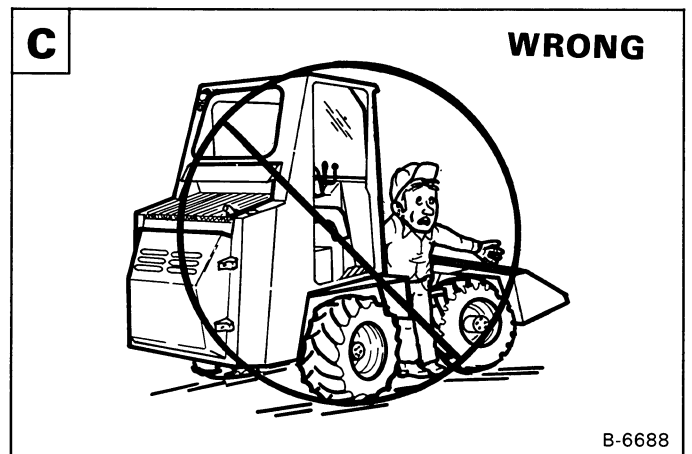
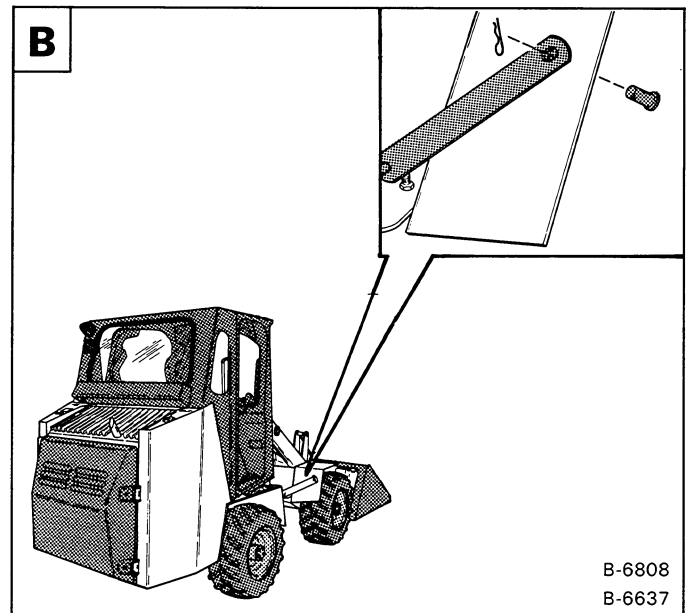
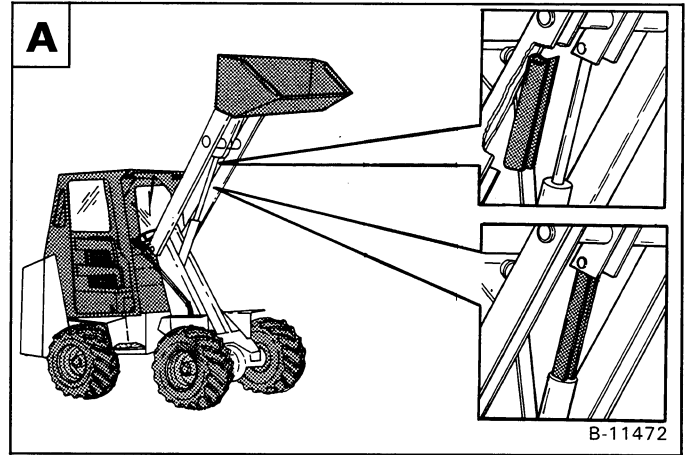

TRANSPORTING THE BOBCAT LOADER

Procedure



WARNING

Steel loading ramps are needed to support the weight of the machine when loading onto a transport vehicle. Wood ramps may break and cause personal injury.

W-2058-0887

A loader with an empty bucket or no attachment must be loaded backwards onto the transport vehicle **A**.

Use the following procedure to fasten the Bobcat loader to the transport vehicle:

1. Lower the bucket or attachment to the floor. Stop the engine.
2. Install the steering frame lock (See Page 1–3).
3. Install chains to hold the loader in position during sudden stops or when going up or down slopes.
4. Put a chain through the tube on the lift arms **B**. Fasten the chain to both sides of the transport vehicle.
5. Fasten a chain to each frame mount under the rear of the loader and to the transport vehicle **C**.
6. Use chain binders to tighten all the chains.

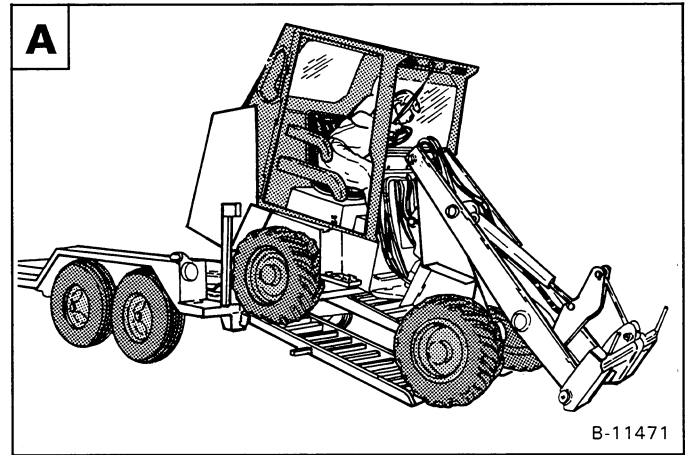

B-11471

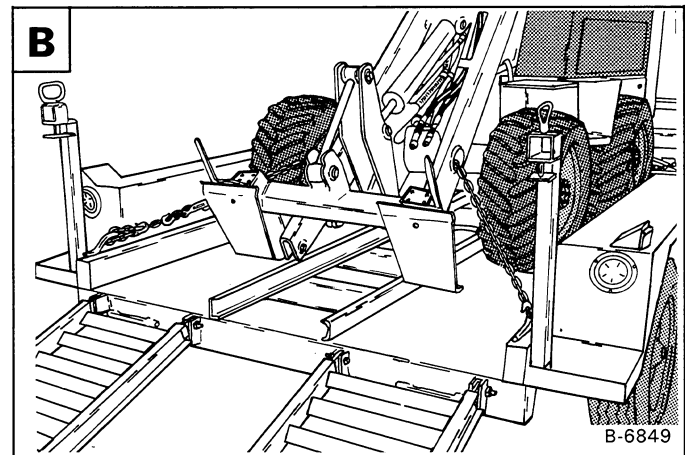

B-6849

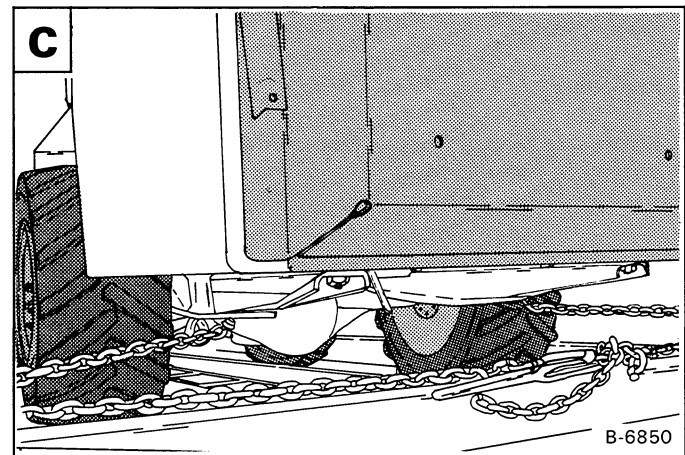

B-6850

OPERATOR RESTRAINT SYSTEM

Description

The operator restraint system consists of pivoting restraint arms. The system is provided to give additional restraint to keep an operator within the safety zone of the operator cab **A**.

The restraint arms are connected to the foot pedal interlock which will not allow the machine to be driven when the restraint arms are in the up position. Only when the operator is in the seat with seat belt buckled and with the restraint arms lowered can the loader be driven.

Inspection of the Operator Restraint System

To check the correct function do the following:

1. Sit in the operator seat and fasten the seat belt snugly.
2. Pull the restraint arms down and start the engine.

NOTE: The centering mechanism must be in neutral position before the starter will engage.

3. The loader may be driven forward or backward by toeing or heeling the foot pedal (the back-up alarm must sound when the loader is moved in the reverse direction).
4. With the engine running and loader not moving, raise the restraint arms. Try to operate the foot pedal in both directions. The loader must not move.
5. Stop the engine. Unfasten the seat belt.

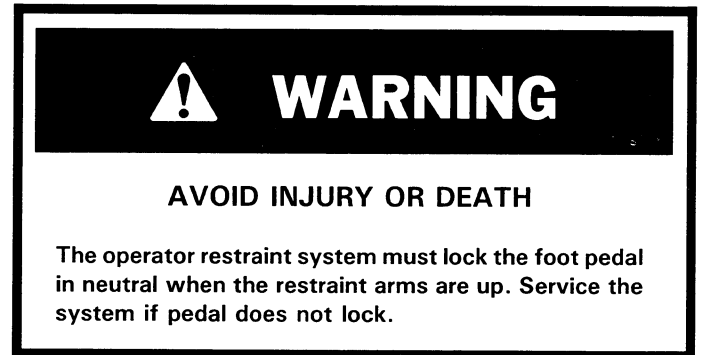
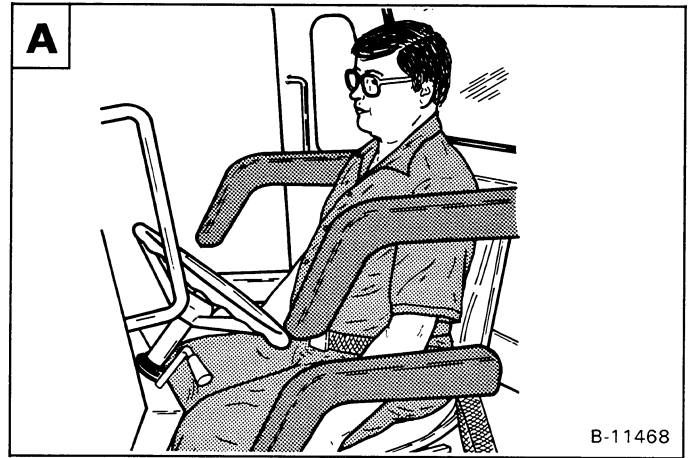

Servicing the Operator Restraint System

1. Clean any debris or dirt from moving parts **B**.
2. Inspect the arms, linkage and interlock for correct operation. Make sure all bolts are tight.
3. If the restraint system does not function correctly when inspected, correct or adjust before operating the loader.

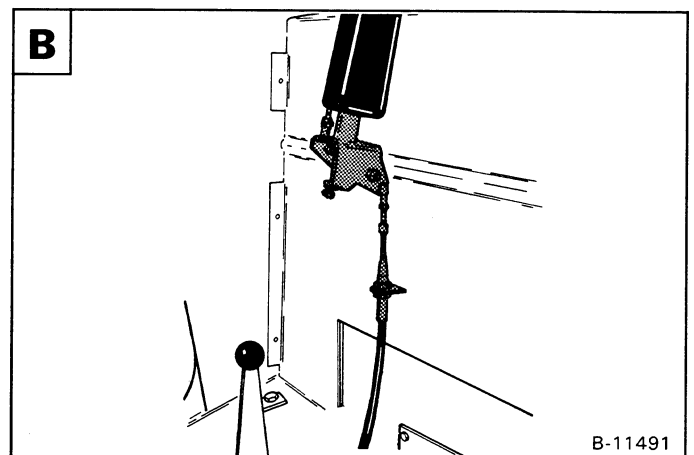

USING AN EXTRA BATTERY (JUMP STARTING)

Procedure

If it is necessary to use an extra battery to start the engine, use the following procedure:

This is a two person operation. There must be one person in the operator's seat and one person to connect and disconnect the battery cables.

1. The key switch must be in the "OFF" position.
2. The extra battery must be of the same voltage as the loader battery.
3. Connect the end of the first cable to the positive (+) terminal (Item 1) of the extra battery. Connect the other end of the same cable to the positive (+) terminal (Item 2) of the loader battery **A**.
4. Connect the end of the second cable to the negative (-) terminal (Item 3) of the extra battery. Connect the other end of the same cable to the frame (Item 4) **A**.

NOTE: Do not connect directly to the negative (-) terminal of the loader battery because it can cause a spark and may cause the battery to explode.

5. Keep the cables away from moving parts.
6. Start the engine (See the Operator's Manual "Cold Starting
7. After the engine is running. Remove the cable connected to the frame first.
8. Then remove the cable connected to the loader battery.

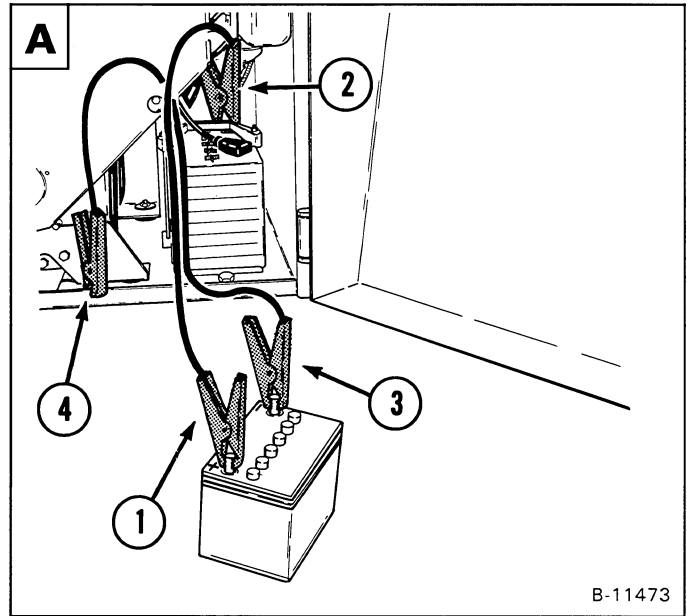

B-11473



WARNING

Keep arcs, sparks, flames and lighted tobacco away from batteries. When "jumping" from an extra battery make final connection (negative) at engine frame.

Do not jump start or charge a frozen battery. Warm battery to 60° F. (16° C.) before connecting to a charger. Unplug charger before connecting or disconnecting cables at battery. Battery gas can explode and cause serious injury.

W-2066-1285

IMPORTANT

Damage to the alternator can occur if:

- Engine is operated with battery cables disconnected.
- Battery cables are connected when using a fast charger or when welding on the loader (Remove both cables from the battery).
- Extra battery cables (booster cables) are connected wrong.

I-2023-1285



WARNING

Batteries contain acid which burns eyes and skin on contact. Wear goggles, protective clothing and rubber gloves to keep acid off body.

In case of acid contact, wash immediately with water for several minutes and get medical attention in case of eye contact.

W-2065-1286

HYDRAULIC SYSTEM

	Section Number
HYDRAULIC SYSTEM (S/N 12001 & ABOVE)	2A
HYDRAULIC SYSTEM (S/N 11999 & BELOW)	2B

**HYDRAULIC
SYSTEM**

**2A HYDRAULIC
SYSTEM**

**2B HYDRAULIC
SYSTEM**

2A HYDRAULIC SYSTEM

TROUBLESHOOTING

The following troubleshooting chart is provided as an assistance in locating and correcting problems which are most common. Many of the recommended procedures must be done by authorized Bobcat Service Personnel only.

PROBLEM	CAUSE
The hydraulic system will not operate.	1, 2, 3, 4, 5
Slow hydraulic system action.	1, 3, 5, 6, 7, 8, 9, 10, 12
Hydraulic action is not smooth.	1, 3, 5, 7, 8, 10, 11
Slow or no hydraulic action on one section of control valve.	2, 6, 13, 14
Lift arms go up slowly at full engine RPM.	1, 3, 5, 6, 7, 8, 9, 11, 13, 15, 16
Lift arms or Bob-Tach move with the linkage in neutral position.	6, 15
Lift arms come down with linkage in neutral position.	6, 16, 17, 18, 19
The bucket does not self-level.	20, 21, 22
The bucket will partially self-level.	20, 21
The bucket has no power to roll forward.	22
The bucket does not roll back.	21

KEY TO CORRECT THE CAUSE

1. The hydraulic reservoir fluid is not at the correct level.
2. The linkage is disconnected.
3. The hydraulic pump has a defect.
4. The relief valve is not set at the correct pressure.
5. Slow engine RPM.
6. The linkage is not adjusted correctly.
7. Auxiliary hydraulics are in "detent" position.
8. Suction leak in the hydraulic system.
9. Fluid is cold.
10. Flow divider valve is not working correctly.
11. Internal restriction.
12. Steering relief valve is not at the correct pressure setting.
13. Cylinder seals are leaking.
14. Port relief valve is not set at the correct pressure.
15. Spool in the valve section is not returning to neutral or spring is broken.
16. Internal leak at the lift cylinder.
17. External leak at the lift cylinder.
18. Port relief valve seal is leaking.
19. Load check in valve section has a defect.
20. Check the flow divider in the bucket position valve.
21. Check the unloading spool in the bucket position valve.
22. Check the port relief valve in the valve section.

IMPORTANT

When making repairs on hydrostatic and hydraulic systems, clean the work area before disassembly and keep all parts clean. Always use caps and plugs on hoses, tubelines and ports to keep dirt out. Dirt can quickly damage the system.

I-2003-0284

Flare Connections

Use the following procedure to tighten the flare fitting:

Tighten the nut until it makes contact with the seat.

Make a mark across the "flats" of both the male and female parts of the connection **A**.

Use the chart to find the correct tightness needed **B**.

If the fitting leaks after tightening, disconnect it and inspect the seat area for damage.

O-ring Face Seal Connection

Tube or hose assembly installation is faster and more reliable **C**.

Tube assemblies slide together. There is no need to push or pry into position. When the fitting is tightened, you can "feel" when the fitting is tight to eliminate leakage cause by under or over torqued fittings.

Use vaseline petroleum jelly to hold the O-ring in position until the fittings are assembled.

Straight Thread O-ring Fitting

When installing this fitting, the O-ring must be first lubricated. Loosen the jam nut, install the fitting into place, then tighten the jam nut. Tighten the jam nut until it and the washer are tight against the surface **D**.

Tubelines and Hoses

Make replacement of tubelines which are bent or have become flat. There will be a restriction of fluid flow, which give a slow hydraulic action and cause heat.

Make replacement of hoses which show signs of wear, damage or weather cracked rubber.

When installing tubelines or hoses, make sure you use two wrenches when loosening or tightening them.

A

Mark a Line on Nut Flats of Both Nuts

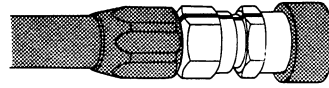

Tighten to Correct Amount from Chart

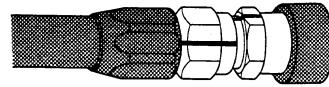

A-1897

B

Wrench Size	Tube Size Outside Dia.	Thread Size	Rotate No. of Hex Flats
5/8"	5/16"	1/2" - 20	2-1/2
11/16"	3/8"	9/16" - 18	2
7/8"	1/2"	3/4" - 16	2
1"	5/8"	7/8" - 14	1-1/2 - 2
1-1/4"	3/4"	1-1/16" - 12	1
1-3/8"	1"	1-5/16" - 12	3/4 - 1
2"	1-1/4"	1-5/8" - 12	3/4 - 1
2-1/4"	1-1/2"	1-7/8" - 12	1/2 - 3/4

C

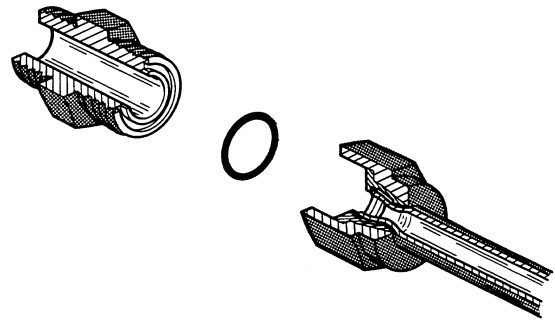

B-7575

D

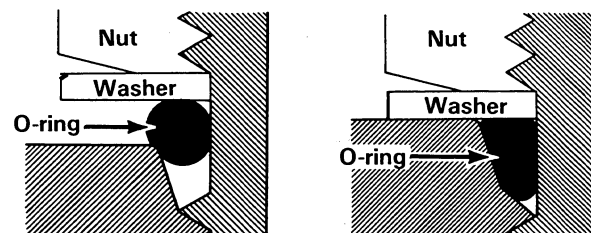

A-1852

LIFT CYLINDER

Checking the Lift Cylinder

Lower the lift arms. Stop the engine. Activate the hydraulic controls to release the hydraulic pressure.

Install the frame lock (See Page 1–3).

Lift and block the loader (See Page 1–2).

Disconnect the hose that goes to the base end of the lift cylinder. Put a plug in the hose.

Start the engine. Activate the lift control to lower the lift arms.

If there is any leakage at the open port, remove the cylinder for repair.

Removal and Installation

Install the frame lock (See Page 1–3).

Lift and block the loader (See Page 1–2).

Start the engine. Roll the Bob-Tach fully forward. Put jackstands under the Bob-Tach to hold the lift arms when the lift cylinder is removed. Lower the lift arms. Stop the engine. Activate the hydraulic controls to release the hydraulic pressure.

Mark the hoses for correct installation.

Disconnect the hydraulic hoses.

Remove the snap ring (Item 1) and washer at the base end pivot pin **A**.

Remove the snap ring (Item 1) and washer at the rod end pivot pin **B**.

Use a brass punch and hammer and remove the pivot pins.

Remove the lift cylinder from the loader.

NOTE: SEE COMPONENT REPAIR MANUAL FOR DISASSEMBLY AND ASSEMBLY OF THE LIFT CYLINDER.

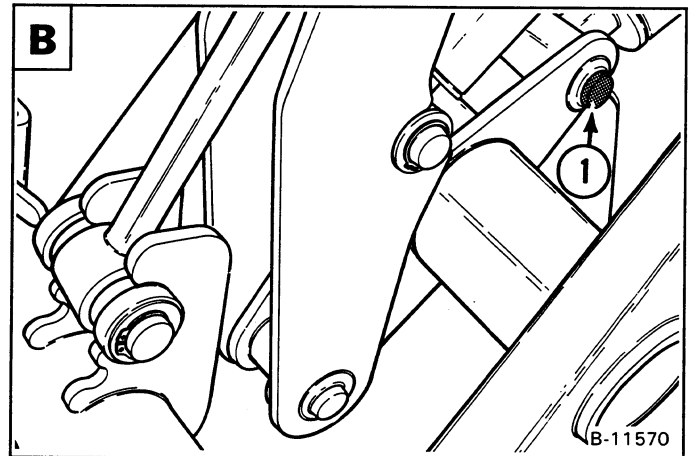
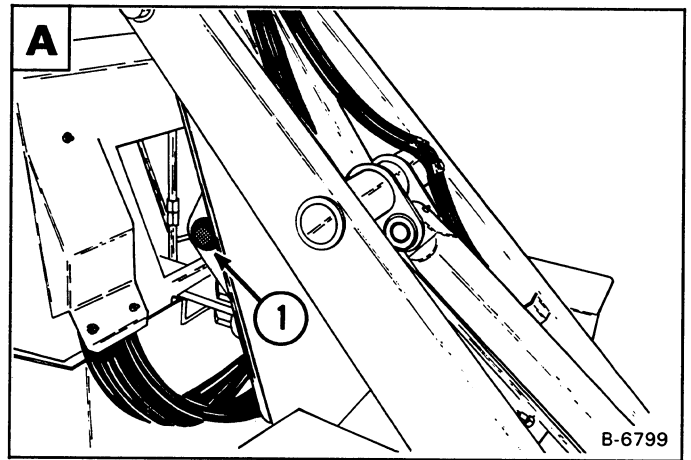

WARNING

Diesel fuel or hydraulic fluid under pressure can penetrate skin or eyes causing serious injury. Fluid leaks under pressure may not be visible. Use a piece of cardboard or wood to find leaks. Do not use your bare hand. Wear safety goggles. If fluid enters skin or eyes, get immediate medical attention.

W-2074-1285

TILT CYLINDER

Checking the Tilt Cylinder

Lower the lift arms. Stop the engine. Activate the hydraulic controls to release the hydraulic pressure.

Install the frame lock (See Page 1-3).

Lift and block the loader (See Page 1-2).

Disconnect the hose that goes to the base end of the tilt cylinder. Put a plug in the hose.

Start the engine. Activate the tilt control to roll the Bob-Tach backwards.

If there is leakage at the open port, remove the cylinder for repair.

Removal and Installation

Install the frame lock (See Page 1-3).

Lift and block the loader (See Page 1-2).

Start the engine. Roll the Bob-Tach fully forward until it touches the floor. Stop the engine. Activate the hydraulic controls to release the hydraulic pressure.

Mark the hoses for correct installation.

Disconnect the hydraulic hoses.

Remove the snap ring (Item 1) and washer at the base end pivot pin **A**.

Remove the snap ring (Item 1) and washer at the rod end pivot pin **B**.

Use a brass punch and hammer and remove the pivot pins.

Remove the tilt cylinder from the loader.

NOTE: SEE COMPONENT REPAIR MANUAL FOR DISASSEMBLY AND ASSEMBLY OF THE TILT CYLINDER.

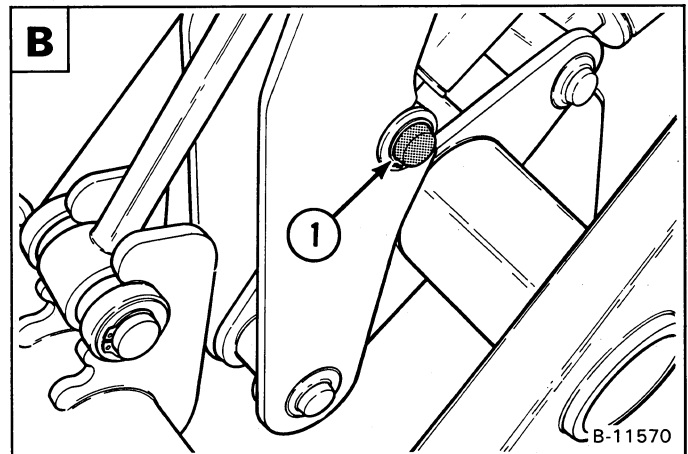
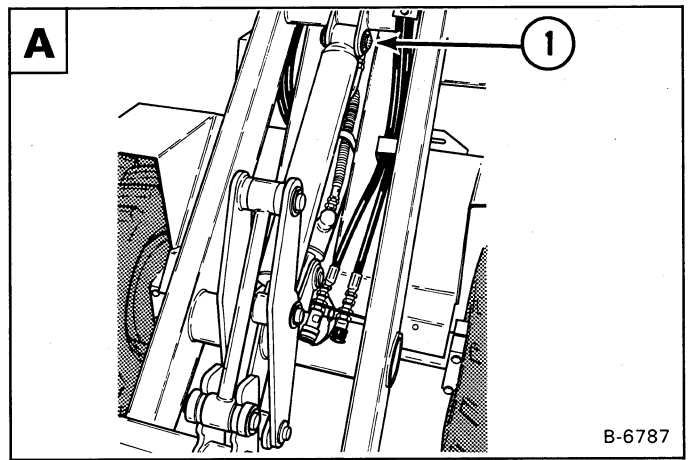

WARNING

Diesel fuel or hydraulic fluid under pressure can penetrate skin or eyes causing serious injury. Fluid leaks under pressure may not be visible. Use a piece of cardboard or wood to find leaks. Do not use your bare hand. Wear safety goggles. If fluid enters skin or eyes, get immediate medical attention.

W-2074-1285

STEERING CYLINDER

Checking the Steering Cylinder

Lower the lift arms. Stop the engine. Activate all the hydraulic controls to release the hydraulic pressure.

Install the frame lock (See Page 1–3).

Remove the floor panel (See Page 5–5).

Disconnect the hose at the base end of the steering cylinder **A**. Put a plug in the hose. Start the engine. Operate the steering wheel. If there is leakage at the open port, remove the cylinder for repair.

Removal and Installation

Install the frame lock (See Page 1–3).

Lift and block the loader (See Page 1–2).

Remove the floor panel (See Page 5–5).

Mark the hoses for correct installation. Disconnect the hydraulic hoses.

Remove the bolt and nut at the base end pivot pin **A**.

Remove the bolt and nut (Item 1) at the rod end pivot pin **B**.

NOTE: Make sure not to lose the two special washer on each end of the steering cylinder.

Use a brass punch and hammer and remove the pivot pins.

Remove the steering cylinder from the loader.

NOTE: SEE COMPONENT REPAIR MANUAL FOR DISASSEMBLY AND ASSEMBLY OF THE STEERING CYLINDER.

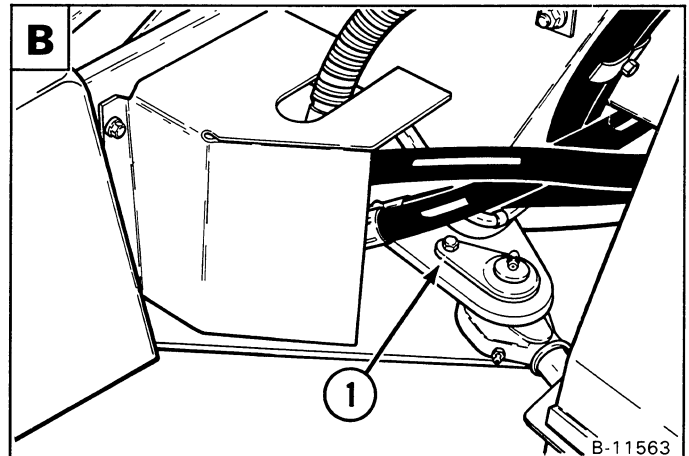
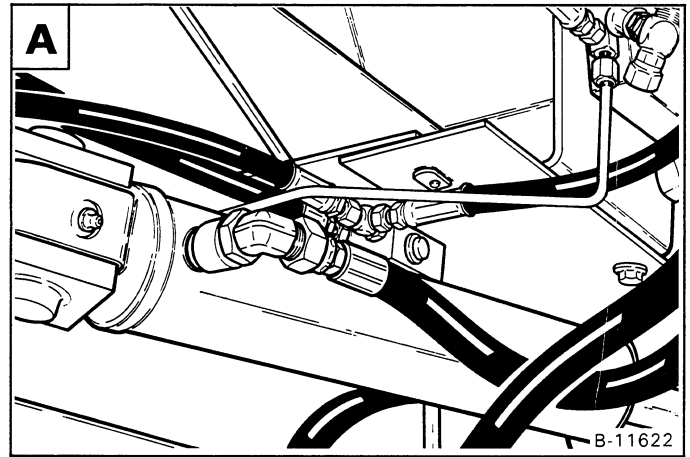

WARNING

Diesel fuel or hydraulic fluid under pressure can penetrate skin or eyes causing serious injury. Fluid leaks under pressure may not be visible. Use a piece of cardboard or wood to find leaks. Do not use your bare hand. Wear safety goggles. If fluid enters skin or eyes, get immediate medical attention.

W-2074-1285

HYDRAULIC CONTROL VALVE

Check the Main Relief Valve

The tool listed will be needed to do the following procedure:

MEL-10006 – Hydraulic Test Kit

Lower the lift arms. Stop the engine. Install the frame lock (See Page 1–3).

Lift and block the loader (See Page 1–2).

Connect a gauge to the diagnostic quick coupler for the hydraulic pump **A**.

Start the engine. Run the engine at full RPM. Operate the tilt control to tilt the Bob-Tach backward and hold this position. The pressure must increase to 2275 - 2375 PSI (15686 - 16376 kPa).

If the pressure is not correct, adjust, repair or replace the main relief valve.

Main Relief Valve Removal and Installation

Stop the engine. Activate the hydraulic controls to release the hydraulic pressure.

Remove the cover from the steering column (See Page 5–7).
Remove the floor panel (See Page 5–5).

Clean the area around the control valve. Remove the main relief valve from the control valve **B**.

Remove the O-rings and back-up washers **C**. Clean the main relief valve in clean solvent. Blow dry with compressed air.

Install new O-rings and back-up washers. Install the main relief and tighten to 35 - 40 ft.lbs. (47 - 54 Nm) torque. Check the operation of the main relief valve again. If the pressure is not correct, adjust the main relief. Remove the end cap (Item 1) **C**. Turn the adjustment screw in or out until the pressure is correct. If the correct pressure can not be reached, replace the main relief valve.

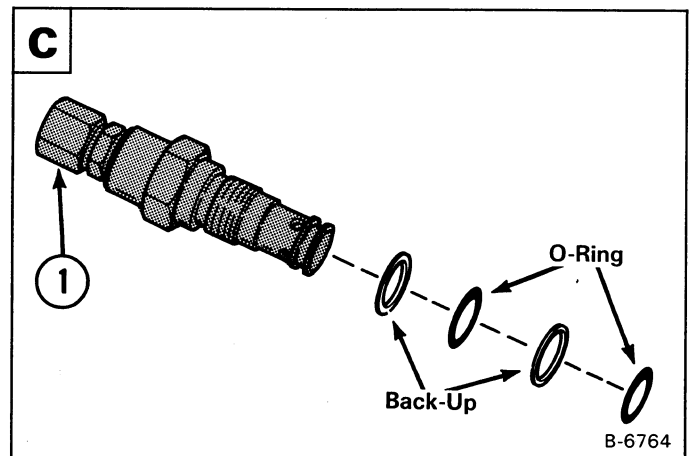
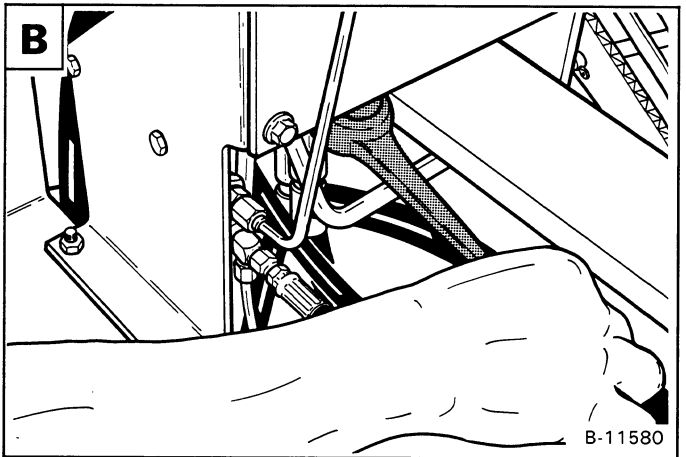
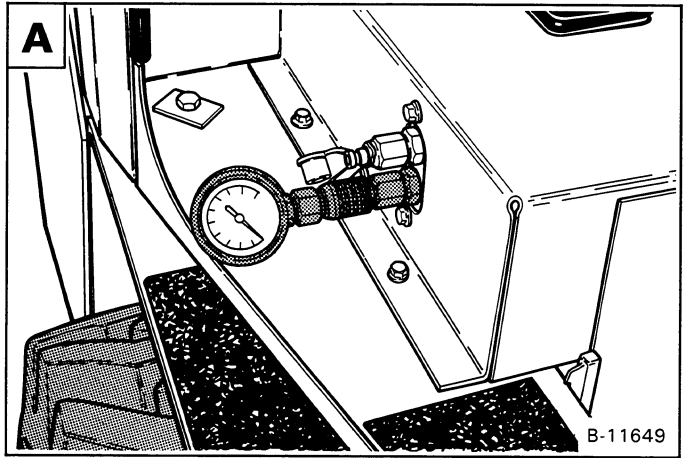

HYDRAULIC CONTROL VALVE (Cont'd)

Removal and Installation

Lower the lift arms. Stop the engine. Activate the hydraulic controls to release the hydraulic pressure.

Install the frame lock (See Page 1–3).

Remove the shield over the control valve on the outside of the operator cab (See Page 5–8).

Remove the cover at the steering column (See Page 5–7).

Remove the floor panel (See Page 5–5).

Disconnect the linkages at the control valve spools **A**.

Installation: Make sure to adjust the clevis on the valve spool as shown in figure **A**.

Mark the hoses and tubelines for correct installation. Disconnect the tubelines at the control valve **B**.

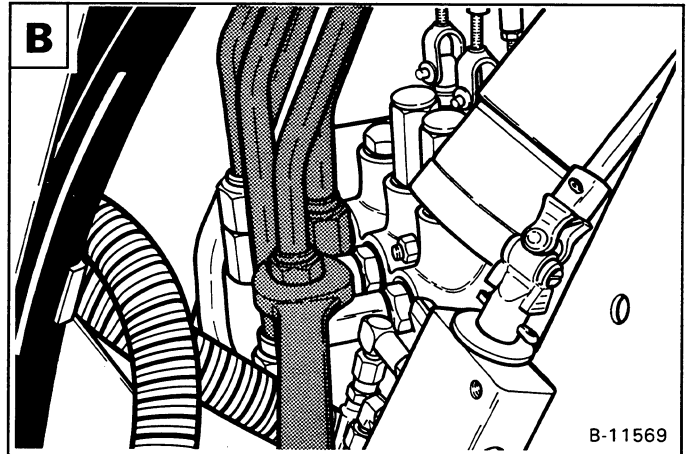
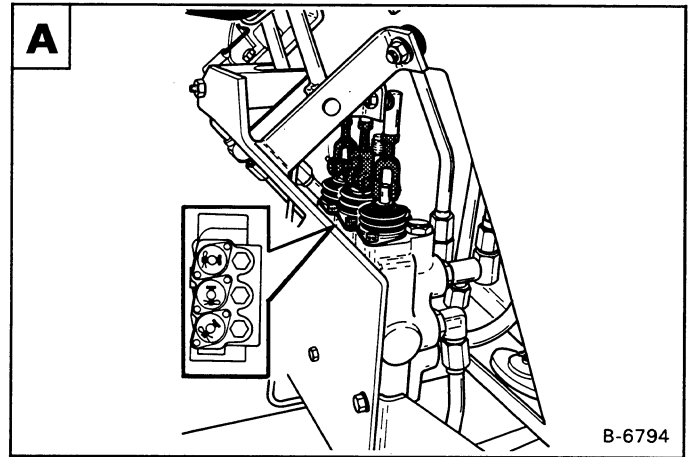

Remove the bolts that fasten the control valve to the mounting plate **C**.

Remove the control valve from the loader.

NOTE: SEE COMPONENT REPAIR MANUAL FOR DISASSEMBLY AND ASSEMBLY OF THE CONTROL VALVE.

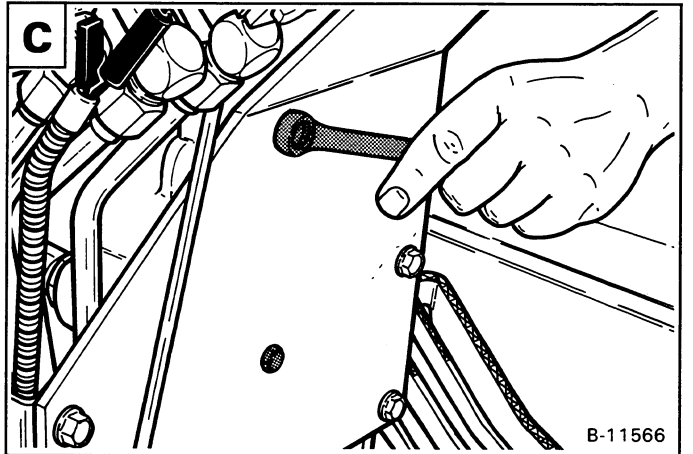

HYDRAULIC PUMP

Checking Output of the Hydraulic Pump

The tools listed will be needed to do the following procedure:

MEL-10003 — Hydraulic Tester
MEL-10006 — Hydraulic Test Kit

NOTE: Make sure that all the air is removed from the system before beginning the test. Air in the system will give an inaccurate test.

Install the frame lock (See Page 1—3).

Lift and block the loader (See Page 1—2).

Remove the floor panel (See Page 5—5).

Remove the seat and seat pan (See Page 5—6).

Disconnect the OUTLET hose (Item 1) at the hydraulic pump **A**.

Connect the INLET hose of the tester to the OUTLET of the pump.

Connect the OUTLET of the tester to the hose which was removed from the pump.

NOTE: Make sure that the restrictor valve on the tester is fully open.

Start the engine and run at the idle RPM. Make sure the tester is connected correctly. If no flow is indicated on the tester, the hoses are connected wrong.

Increase the engine speed to full RPM*. Warm the fluid to 140° F. (60° C.) by turning the restrictor knob on the tester to about 1000 PSI (6895 kPa). DO NOT exceed system pressure.

Open the restrictor and record the free flow (GPM) at full RPM*.

Tilt the Bob-Tach full back and continue to hold. Record the highest pressure (PSI) and flow (GPM). The high pressure must be at least 80% of free flow.

$$x = \frac{\text{HIGH PRESSURE FLOW (GPM)}}{\text{FREE FLOW (GPM)}} \times 100$$

A low percentage may indicate a failed hydraulic pump or it may be caused by air in the system.

* Make reference to Specifications (Section 8) for system relief pressure and full RPM. The system relief pressure must be per specification before the test is run.

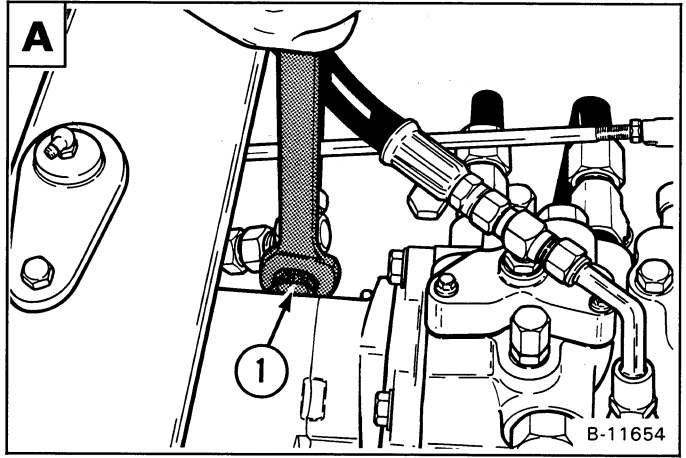

IMPORTANT

Be careful when turning the flow control restrictor at the hydraulic tester. When the tester is connected this way there is no relief valve in the system. DO NOT close the flow restrictor valve, on the tester, all the way.

HYDRAULIC PUMP (Cont'd)

Removal and Installation

IMPORTANT

When making repairs on hydrostatic and hydraulic systems, clean the work area before disassembly and keep all parts clean. Always use caps and plugs on hoses, tubelines and ports to keep dirt out. Dirt can quickly damage the system.

I-2003-0284

Lower the lift arms. Stop the engine. Activate the hydraulic controls to release the hydraulic pressure.

Install the frame lock (See Page 1–3).

Remove the floor panel (See Page 5–5).

Remove the seat and seat pan (See Page 5–6).

Clean the area around the hydraulic pump.

Mark the hoses and tubelines for correct installation.

Disconnect the outlet hose **A**.

Disconnect the tubelines **B**.

Support the hydraulic pump.

Remove the two mounting bolts **C**.

Remove the hydraulic pump from the hydrostatic pump **D**.

NOTE: SEE COMPONENT REPAIR MANUAL FOR DISASSEMBLY AND ASSEMBLY OF THE HYDRAULIC PUMP.

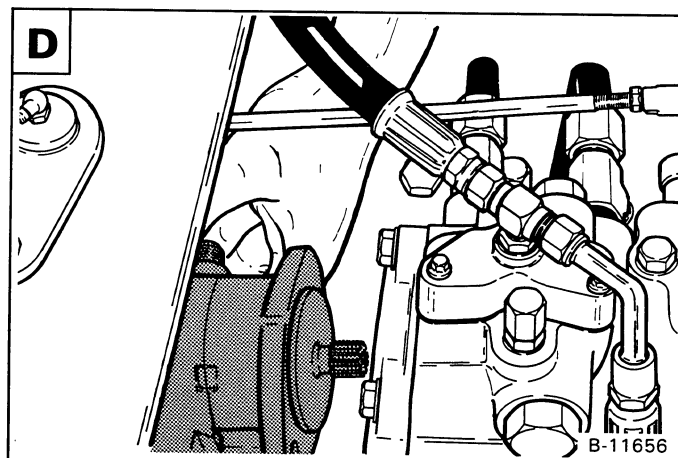
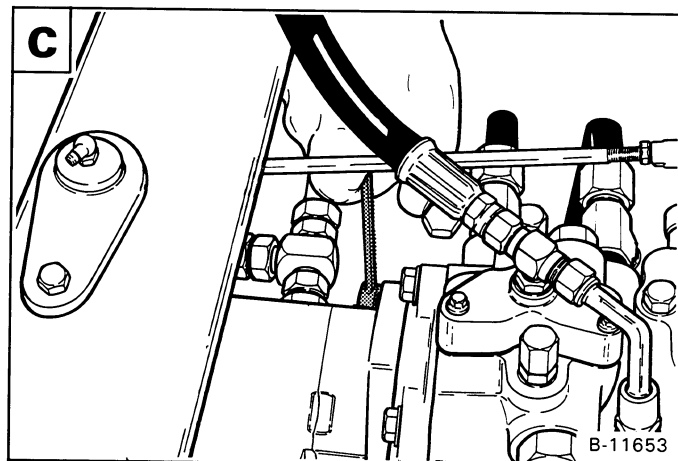
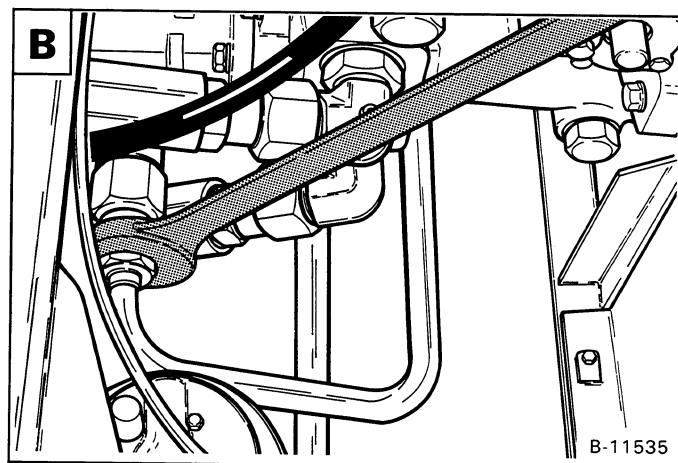
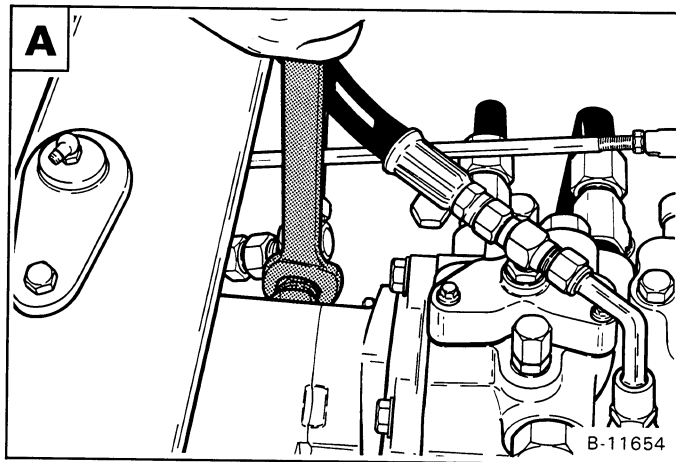



Suggest:

If the above button click is invalid.

Please download this document

first, and then click the above link

to download the complete manual.

Thank you so much for reading

BUCKET POSITION VALVE (S/N 12026 & Below)

Removal and Installation

Lower the lift arms. Stop the engine. Activate the hydraulic controls to release the hydraulic pressure.

Install the frame lock (See Page 1–3).

Remove the bolts which fasten the cover to the frame **A**.

Remove the cover.

Clean the area around the bucket position valve.

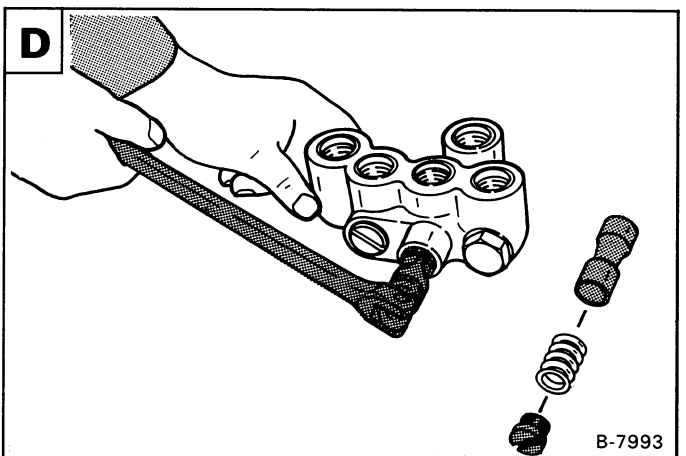
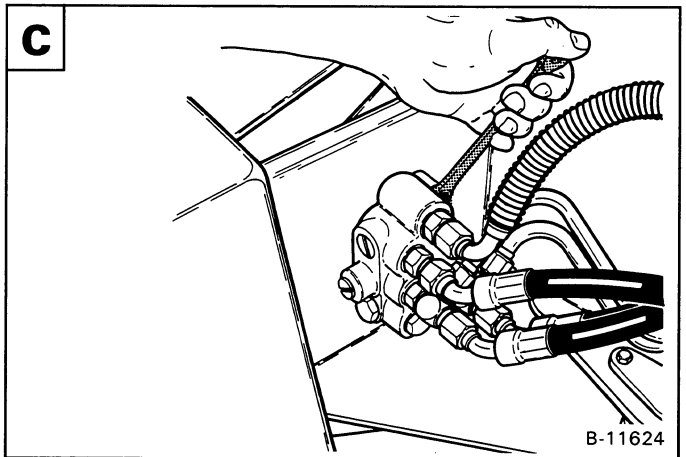
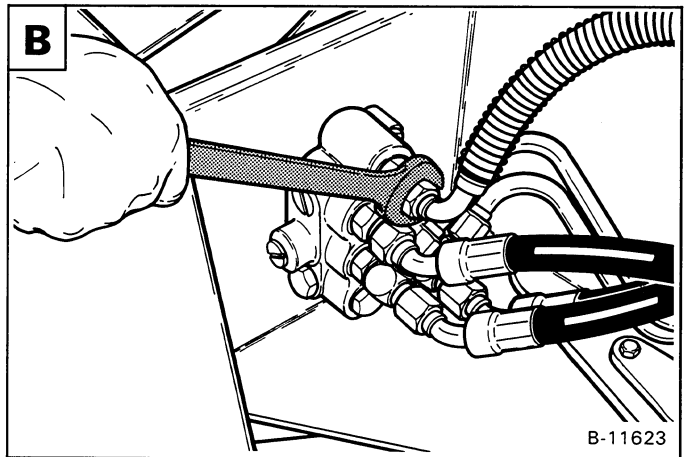
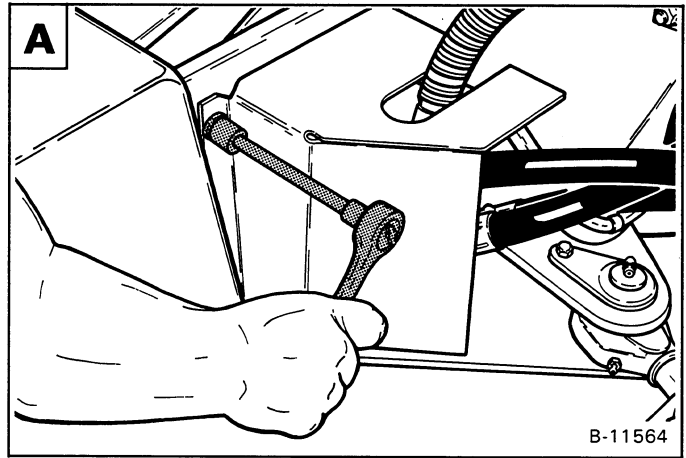

IMPORTANT

When making repairs on hydrostatic and hydraulic systems, clean the work area before disassembly and keep all parts clean. Always use caps and plugs on hoses, tubelines and ports to keep dirt out. Dirt can quickly damage the system.

I-2003-0284

Mark the hoses for correct installation.

Disconnect all the hoses at the bucket position valve **A**.

Remove the bolts which fasten the valve to the frame **C**.

Remove the bucket position valve from the loader.

Disassembly and Assembly

NOTE: Make sure to mark the plugs and valves for correct assembly.

Remove the plug, spring and O-ring **D**.

<https://www.ebooklibonline.com>

Hello dear friend!

Thank you very much for reading.

Enter the link into your browser.

The full manual is available for immediate download.

<https://www.ebooklibonline.com>