

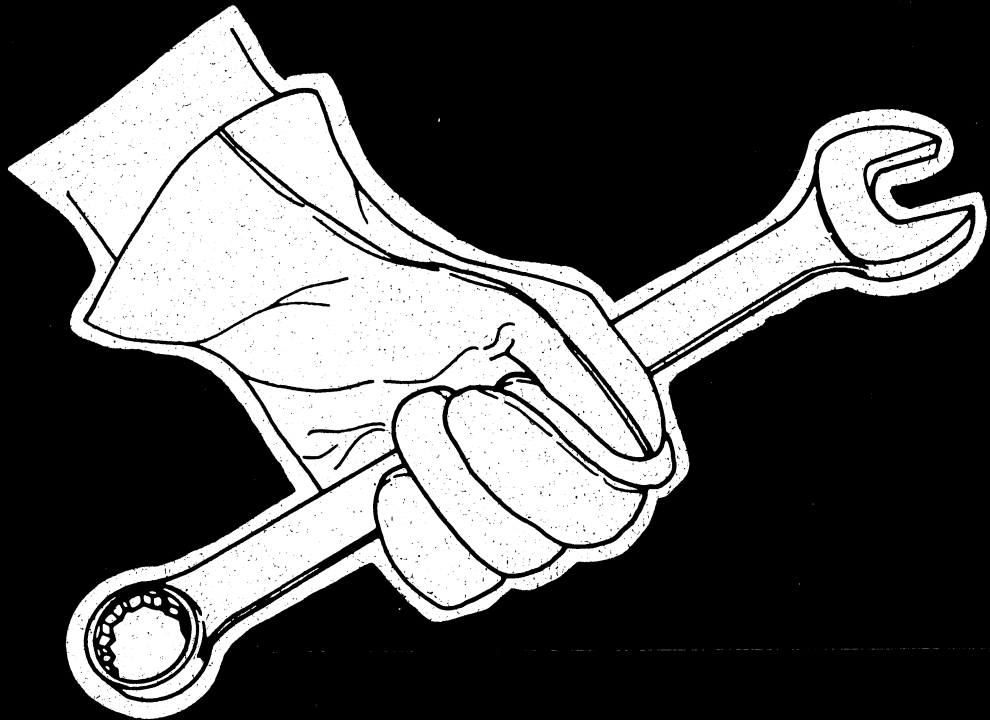

**bobcat**

1213

# SERVICE MANUAL



# MAINTENANCE SAFETY



## WARNING

Instructions are necessary before operating or servicing machine. Read and understand the Operation & Maintenance Manual, Operator's Handbook and signs (decals) on machine. Follow warnings and instructions in the manuals when making repairs, adjustments or servicing. Check for correct function after adjustments, repairs or service. Untrained operators and failure to follow instructions can cause injury or death.

W-2003-0903



**Safety Alert Symbol:** This symbol with a warning statement, means: "Warning, be alert! Your safety is involved!" Carefully read the message that follows.

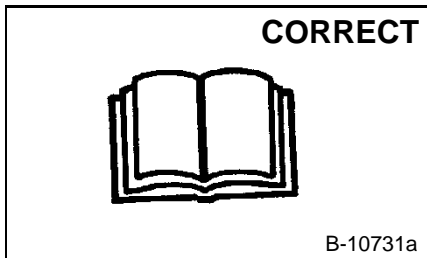

Never service the Bobcat Skid-Steer Loader without instructions.

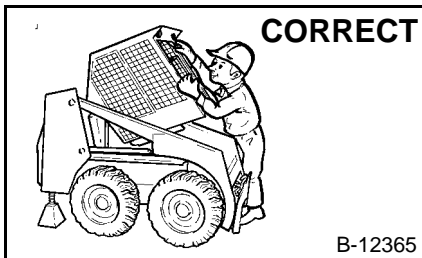

Use the correct procedure to lift or lower operator cab.

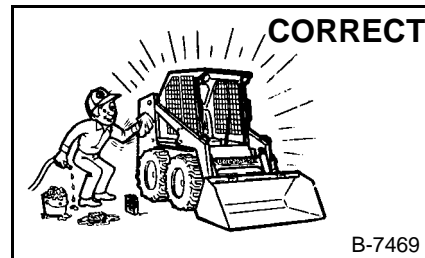

Cleaning and maintenance are required daily.

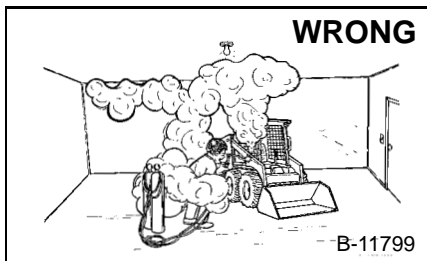

- Have good ventilation when welding or grinding painted parts.
- Wear dust mask when grinding painted parts. Toxic dust and gas can be produced.
- Avoid exhaust fume leaks which can kill without warning. Exhaust system must be tightly sealed.

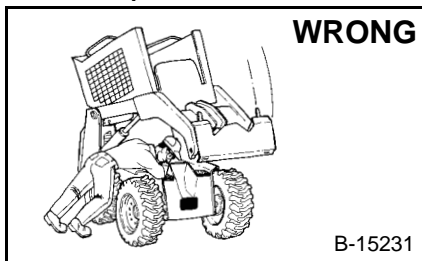

Disconnecting or loosening any hydraulic tubeline, hose, fitting, component or a part failure can cause lift arms to drop. Do not go under lift arms when raised unless supported by an approved lift arm support device. Replace it if damaged.

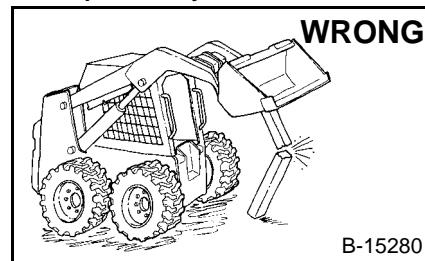

- Never work on loader with lift arms up unless lift arms are held by an approved lift arm support device. Replace if damaged.
- Never modify equipment or add attachments not approved by Bobcat Company.

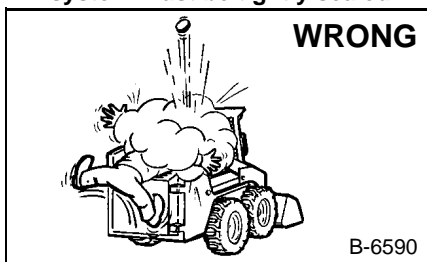

- Stop, cool and clean engine of flammable materials before checking fluids.
- Never service or adjust loader with the engine running unless instructed to do so in the manual.
- Avoid contact with leaking hydraulic fluid or diesel fuel under pressure. It can penetrate the skin or eyes.
- Never fill fuel tank with engine running, while smoking or when near open flame.

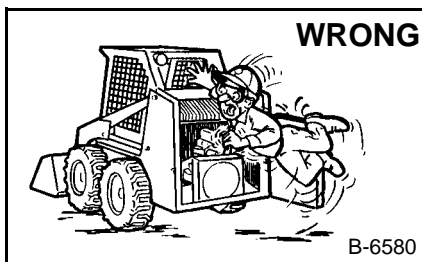

- Keep body, jewelry and clothing away from moving parts, electrical contact, hot parts and exhaust.
- Wear eye protection to guard from battery acid, compressed springs, fluids under pressure and flying debris when engines are running or tools are used. Use eye protection approved for type of welding.
- Keep rear door closed except for service. Close and latch door before operating the loader.

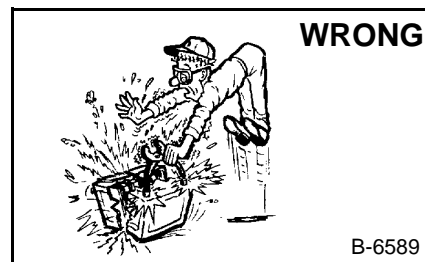

- Lead-acid batteries produce flammable and explosive gases.
- Keep arcs, sparks, flames and lighted tobacco away from batteries.
- Batteries contain acid which burns eyes or skin on contact. Wear protective clothing. If acid contacts body, flush well with water. For eye contact flush well and get immediate medical attention.

Maintenance procedures which are given in the Operation & Maintenance Manual can be performed by the owner/operator without any specific technical training. Maintenance procedures which are **not** in the Operation & Maintenance Manual must be performed **ONLY BY QUALIFIED BOBCAT SERVICE PERSONNEL**. Always use genuine Bobcat replacement parts. The Service Safety Training Course is available from your Bobcat dealer.

# FOREWORD

This manual gives the owner/operator necessary operating, servicing and adjustment of the Feller Buncher and overhaul instructions of the drive system, loader hydraulic/hydrostatic system and general main frame parts.

Refer to the Operator's Manual for operating instructions (Starting Procedure, Daily Checks, Bucket Operation, etc.).

A General inspection of the following items must be made whenever the Feller Buncher has had service or repair:

1. Check hydraulic fluid level, engine oil level and fuel supply.
2. Inspect for any sign of fuel, oil or hydraulic fluid leaks.
3. Lubricate the Feller Buncher.
4. Check the condition of the battery and cables.
5. Inspect air cleaner for damage or leaks. Check element and replace as needed.
6. Check electrical charging system.
7. Check the warning lights.
8. Check tires for wear and pressure.
9. Check the tree shear for condition.
10. Inspect Operator Cab, Seat Belt, Seat Bar Safety Treads, Lights, Horn, Safety Signs (Decals), Brake etc.
11. Inspect for loose or broken parts or connections.
12. Operate the Feller Buncher and check all functions.
13. Inform the Owner/Operator of any items that need service.

**PREVENTIVE  
MAINTENANCE**

**HYDRAULIC  
SYSTEM**

**HYDROSTATIC  
SYSTEM**

**DRIVE  
SYSTEM**

**MAIN  
FRAME**

**ELECTRICAL  
SYSTEM**

**ENGINE  
SERVICE**

**TECHNICAL  
DATA**

## CONTENTS

SAFETY INSTRUCTIONS . . . . .	i
FIRE PREVENTION . . . . .	ii
SERIAL NUMBER LOCATIONS . . . . .	iii
DELIVERY REPORT . . . . .	iii
FELLER BUNCHER IDENTIFICATION . . . . .	iv
PREVENTIVE MAINTENANCE . . . . .	1
HYDRAULIC SYSTEM . . . . .	2
HYDROSTATIC SYSTEM . . . . .	3
DRIVE SYSTEM . . . . .	4
MAIN FRAME . . . . .	5
ELECTRICAL SYSTEM . . . . .	6
ENGINE SERVICE . . . . .	7
TECHNICAL DATA . . . . .	8

# I. SAFETY INSTRUCTIONS

## A. SAFETY IS YOUR RESPONSIBILITY

The Feller Buncher is a highly maneuverable and compact machine. In operation, it is rugged and useful under a wide variety of conditions. This presents an operator with hazards which are common for off highway, rough terrain applications but are not unique for use of Bobcat loaders. The Feller Buncher has an internal combustion engine with resultant heat and exhaust. All exhaust gases can kill so the Feller Buncher must be used with adequate ventilation. The Feller Buncher must not be used in an area with explosive dusts or gases or so that the engine exhaust can contact flammable material. The Feller Buncher has a spark arrestor muffler which is required for operation in certain areas.

The dealer recommends the capabilities and restrictions of the Feller Buncher and attachments for each application. The dealer demonstrates the safe operation of the Feller Buncher according to the manufacturer's instructional materials which are also available to all operators. The dealer can also identify unsafe modifications or use of unapproved attachments. The attachments are designed for rated capacity and secure fastening to the Feller Buncher.

The following publications provide information on the safe use of the Feller Buncher:

1. The Delivery Report is used to check whether complete instructions have been given to the new owner.
2. The Operator's Manual delivered with every Feller Buncher gives operating information as well as routine maintenance and service.
3. Every Feller Buncher has machine signs (or decals) which instruct on the safe care and operation of the Feller Buncher. The complete signs and their location are shown in the Operator's Manual. All signs are available from your Bobcat dealer.
4. The Feller Buncher has a plastic Operator Handbook fastened to the operator cab. It has brief instructions always available to the operator. The handbook is available from your Bobcat dealer.
5. The Service Manual and Parts Manual are optional manuals from your Bobcat dealer for use by mechanics to do shop-type service and repair work.

The dealer and owner/operator review the recommended uses of the Feller Buncher at the time of delivery of the Feller Buncher. If change of the use of the Feller Buncher occurs, the owner/operator must remember to ask the dealer for recommendations on the new use of the Feller Buncher.

## B. BEFORE OPERATING THE BOBCAT LOADER

**WARNING**

Operator must have instructions before operating loader. Failure to obey warnings can cause injury or death.

W-2001-0284



This Service Manual was written to give the service personnel instructions on the safe service of the Feller Buncher. READ AND UNDERSTAND THIS SERVICE MANUAL BEFORE SERVICE YOUR FELLER BUNCHER.

**WARNING**

For your safety, warnings are on loader and in manual. Failure to obey warnings can cause injury or death.

W-2044-0284

**IMPORTANT**

This notice identifies procedures which must be followed to avoid damage to the loader.

I-2019-0284

**<https://www.ebooklibonline.com>**

Hello dear friend!

Thank you very much for reading.

Enter the link into your browser.

The full manual is available for immediate download.

**<https://www.ebooklibonline.com>**

## C. SAFE OPERATION NEEDS A QUALIFIED OPERATOR

A QUALIFIED OPERATOR\* MUST DO THE FOLLOWING:

1. UNDERSTAND THE WRITTEN INSTRUCTIONS, RULES AND REGULATIONS
  - a. The written instructions from Melroe Company include the delivery report, loader operator's handbook and manual, attachment manual and machine signs (decals).
  - b. Check the rules and regulations at your location. The rules may include an employer's work safety requirements. Regulations may identify a hazard such as utility supply line.
2. HAVE TRAINING WITH ACTUAL OPERATION
  - a. Operator training must consist of a demonstration and verbal instruction. This training is given by the Bobcat dealer before the Feller Buncher is delivered.
  - b. The new operator should start in an area without bystanders and use all the controls until he can control the Feller Buncher at full use under the conditions for his work area.
3. KNOW THE WORK CONDITIONS
  - a. For each material to be handled, the operator must know how to avoid exceeding the rated operating capacity of the Feller Buncher.
  - b. The operator must know any prohibited uses or work areas for the Feller Buncher. For example, he needs to know about excessive slopes.

\* For an operator to be qualified, he must not use drugs or alcoholic drinks which change his alertness or coordination while working. An operator who is taking prescription drugs must get medical advice on whether or not he can safely operate a machine.

## II. FIRE PREVENTION

The Feller Buncher has several components which are at high temperature under normal operating conditions. The primary source of high temperatures is the engine and exhaust system. The electrical system, if damaged or incorrectly maintained, can be a source of arcs or sparks. These conditions make it necessary to avoid applications where explosive dust or gases can be ignited by arcs, sparks or heat.

Flammable debris (leaves, straw, etc.) must be removed regularly. If flammable debris is allowed to accumulate, it will increase the condition for fire hazard. The Feller Buncher must be cleaned as often as necessary to avoid this accumulation. This flammable debris in the engine compartment can be a fire hazard when the Feller Buncher is parked with a hot engine.

The spark arrestor muffler is designed to control the emission of hot particles from the engine and exhaust system, but the muffler and the exhaust gases are still hot. This spark arrestor muffler does not change the need to avoid use of the Feller Buncher in an atmosphere with explosive dust or gases or where the exhaust can contact flammable material.

1. Do not use the Bobcat Feller Buncher in applications where explosive dust or gases can be ignited by arcs, sparks, hot components or exhaust gases.
2. The operator cab, engine compartment and engine cooling system must be inspected every day and cleaned if necessary to prevent overheating. Remove all flammable material.
3. Check all electrical wiring and connections for damage. Keep the battery terminals clean and tight. Repair or replace any damaged part.
4. Check for damage and leakage at all the fuel, oil and hydraulic tubes, hoses and fittings. Tighten or replace any that show leakage. Always clean fluid spills.
5. Use ether or starting fluids only when approved by the engine manufacturer. Do not use ether or starting fluids on any engine which has glow plugs. These starting aids can cause an explosion and injure bystanders.
6. Always clean the Feller Buncher before doing any welding. Cover rubber hoses, battery and all other flammable parts. Keep a fire extinguisher near the Feller Buncher when welding.
7. Stop the engine and let it cool before adding fuel. No smoking.
8. Use the procedure in Operator's Manual for connecting and charging batteries.
9. Use the procedure in Operator's Manual for servicing the spark arrestor muffler.

### III. SERIAL NUMBER LOCATIONS

Always refer to the correct serial number when ordering parts of making repairs.

#### FELLER BUNCHER SERIAL NUMBER

The Feller Buncher serial number plate is located on the inside of the left upright, above the grill **A**.

Explanation of Feller Buncher Serial Number:

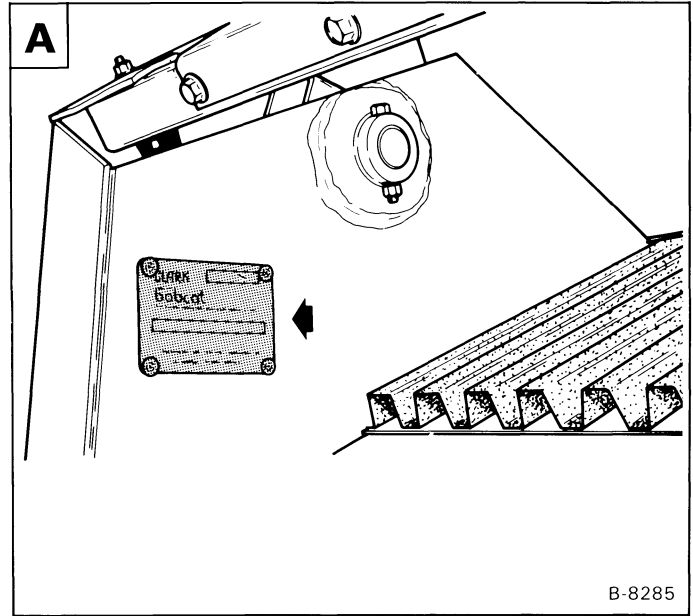
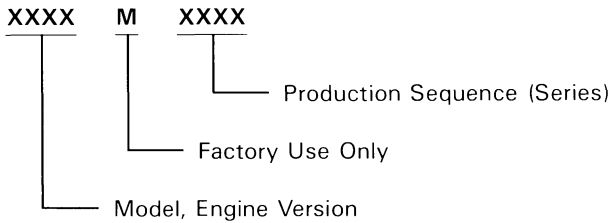

#### ENGINE SERIAL NUMBER LOCATION

The location of the serial number for the engine is on fuel injection pump side and at the rear of the engine block **B**.

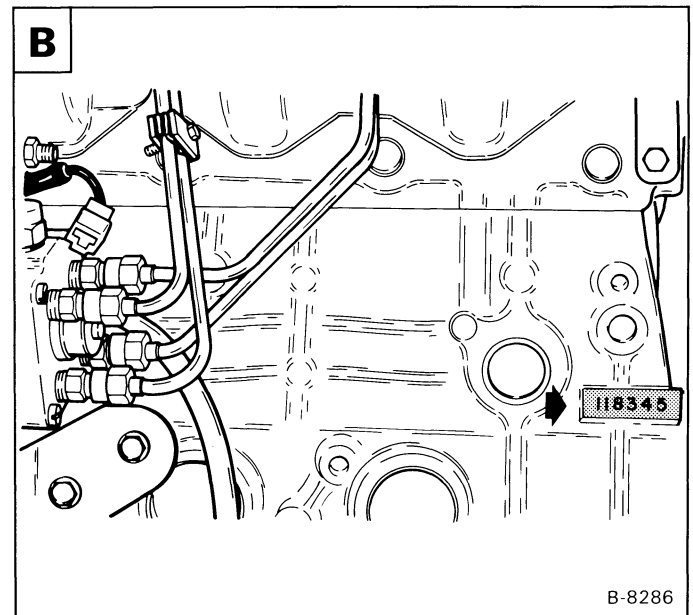

### IV. DELIVERY REPORT

The Delivery Report **C** must be filled out by the dealer and signed by the owner or operator when the Feller Buncher is delivered. An explanation of the form must be given to the owner. Be sure that it is filled out completely before you sign.

**C**

MELROB **Bobcat** DELIVERY REPORT

Dealer Name \_\_\_\_\_ Machine or Attachment Name \_\_\_\_\_  
 Address \_\_\_\_\_ Model No. \_\_\_\_\_  
 City \_\_\_\_\_ State \_\_\_\_\_ Zip \_\_\_\_\_ Serial No. \_\_\_\_\_  
 Customer Name \_\_\_\_\_ Engine Serial No. \_\_\_\_\_  
 Address \_\_\_\_\_ Backhoe Size \_\_\_\_\_  
 City \_\_\_\_\_ State \_\_\_\_\_ Zip \_\_\_\_\_ Application \_\_\_\_\_  
 Date Delivered \_\_\_\_\_

**WARNING**

The following points are to be checked by the operator at the time of delivery:

- 1 Explain delivery report (Operator's Manual, Safety Manual and Operator's Manual) when given to Operator.
- 2 Advise owner that dealer is the source for operator training by providing demonstration, public demonstration and review of job requirements and recommended loader and attachment usage.
- 3 Explain capabilities and restrictions of loader and attachments, for each usage, as specified by Owner/Operator.
- 4 Review Machine Safety Signs, Operator's Manual and Safety Manual instructions.
- 5 Explain Operator Handbook attached with a label in the operator's seat on Model 400 through 900 Series, 500B, 600B & 2000.
- 6 Show how to enter and exit loader safely, with all attachments.
- 7 Demonstrate use of seat belt and seat belt inflator is provided for this model. Seat belts are available for models 400 through 900 Series, 1600 and 2000.
- 8 Demonstrate how to stop, stop turn and park the loader. Also show how to lift and dump the bucket or use other attachments.
- 9 Explain use of operator's cell attachment (if used) and always stop a PTO or PTO-like job, or operate for all buckets and 18 inches, DID ALL models, or remove operator's cell.
- 10 Explain the location and use of Application Key, master or key, mounted from emergency stop openings.
- 11 Explain the use of the rear window opening of the seat when loading in an emergency and DID NOT always, this opening is appropriate to use when it is not used.
- 12 Explain correct operating capacity, for safety, and stability of the loader and attachment.
- 13 Explain correct use of availability of bucket tips and spurs, for use with different materials.
- 14 Explain recommended turning and lubrication procedures.
- 15 Advise owner to use the loader in environments with explosive dusts or gases or with flammable materials (see manual). Explain availability of loader with DS rating for fire hazards.
- 16 Advise Owner/Operator of all available attachments and accessories, such as, 50-Bump Stop, Single Point Lift, Warning Alarm and lights and others.
- 17 Review maintenance procedure with Operator and maintenance man as found in Operator's Manual.
- 18 Explain Warranty Policy and limitations to Owner/Operator. Copy of Warranty Statement found in Operator's Manual and Warranty Booklet enclosed in delivery packet.

The above delivery information has been explained to me. I understand the operation and maintenance of this machine. I also acknowledge the warranty conditions and limitations as outlined in my copy of the warranty statement.

Owner/Operator Signature \_\_\_\_\_ Date \_\_\_\_\_  
 Dealer Representative Signature \_\_\_\_\_ Date \_\_\_\_\_

MELROB, 400 5th St., Duluth, MN 55812-1000, Tel: (612) 271-1000, Fax: (612) 271-1001, www.melrob.com  
 ©2004 MELROB. Printed in U.S.A.

## V. FELLER BUNCHER IDENTIFICATION

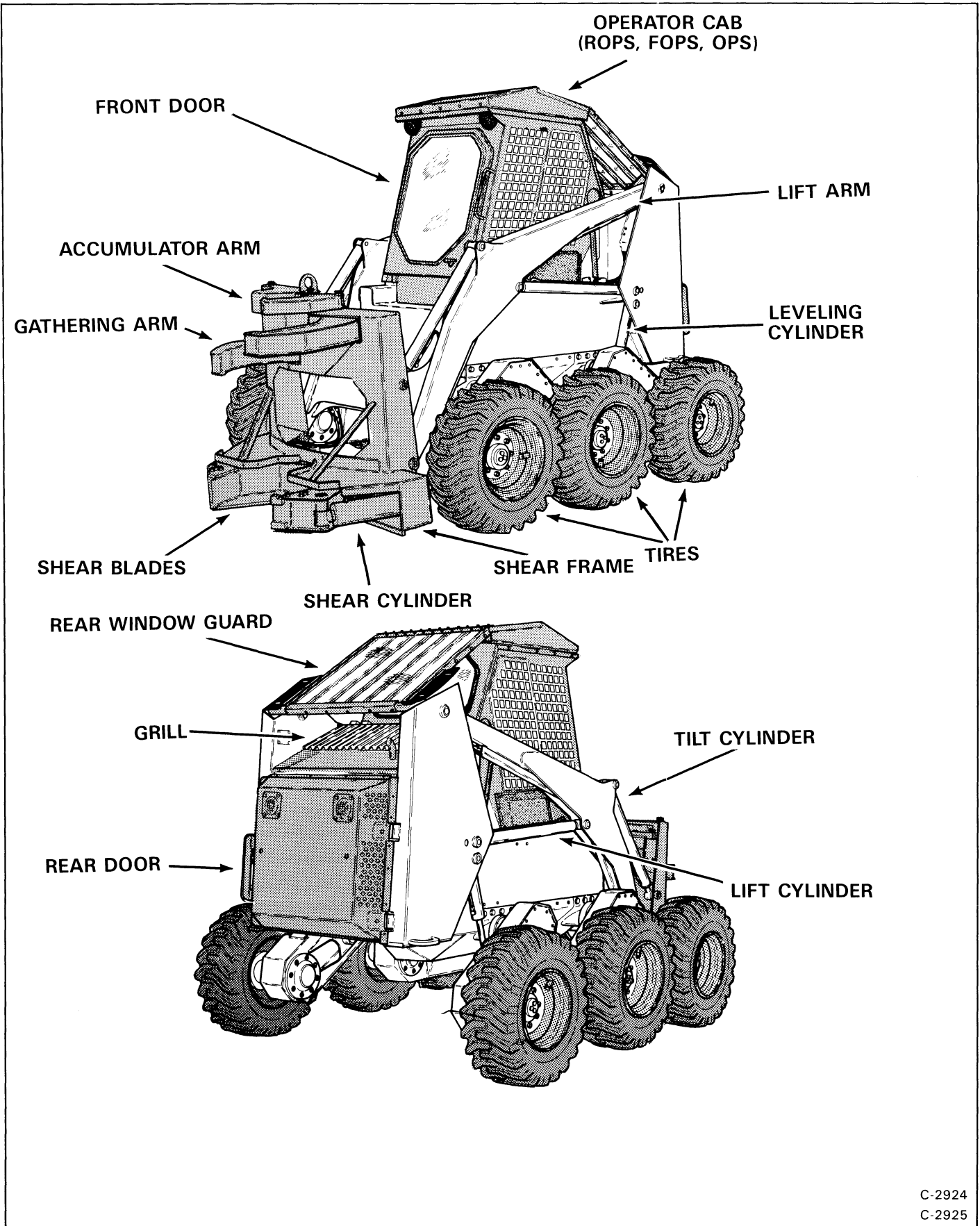

C-2924  
C-2925

ROPS, FOPS, OPS – Roll-Over Protection Structure, Falling Object Protection, Operator Protective Structure, per SAE J231 & SAE J1084. The Feller Buncher is base equipped with a standard operator cab as shown.

## PREVENTIVE MAINTENANCE

	Page Number
AIR CLEANER SERVICE	
Filter Element Replacement . . . . .	1-7
COLD TEMPERATURE STARTING	
Procedure . . . . .	1-16
COOLING SYSTEM	
Coolant Level . . . . .	1-11
Coolant Replacement . . . . .	1-13
Cooling System Maintenance . . . . .	1-11
ELECTRICAL SYSTEM	
Battery Disconnect Switch . . . . .	1-14
Description . . . . .	1-14
Electrical System Maintenance . . . . .	1-14
Using An Extra Battery (Jump Starting) . . . . .	1-15
ENGINE OIL AND FILTER	
Procedure . . . . .	1-9
FELLER BUNCHER LUBRICATION	
Procedure . . . . .	1-22
Pump Drive Coupler . . . . .	1-23
FINAL DRIVE TRANSMISSION	
Chaincase Fluid Level . . . . .	1-20
Wheel End Chaincases . . . . .	1-20
FOOT PEDAL AREA	
Cleaning . . . . .	1-23
FUEL SYSTEM	
Filling the Fuel Tank . . . . .	1-8
Removing Water From the Fuel System . . . . .	1-8
HYDRAULIC AND HYDROSTATIC SYSTEM	
Checking and Adding Fluid . . . . .	1-17
Hydraulic Filter Replacement . . . . .	1-18
Hydrostatic Filter Replacement . . . . .	1-18
LIFT ARM STOP	
Procedure . . . . .	1-4
LIFTING AND BLOCKING THE FELLER BUNCHER	
Procedure . . . . .	1-2
OPERATOR CAB	
Lowering the Operator Cab . . . . .	1-5
Raising the Operator Cab . . . . .	1-5
PARKING BRAKE ADJUSTMENT	
Procedure . . . . .	1-23
PIVOT PINS	
Procedure . . . . .	1-23
REAR DOOR	
Door Latch Adjustment . . . . .	1-6
REMOTE START SWITCH	
Procedure . . . . .	1-24
SERVICE SCHEDULE	
Chart . . . . .	1-1
SPARK ARRESTOR MUFFLER	
Cleaning Spark Arrestor Muffler . . . . .	1-19
TIRE MAINTENANCE	
Tire Pressure . . . . .	1-21
Tire Rotation . . . . .	1-20
Tire Installation on Rim . . . . .	1-21
Wheel Nuts . . . . .	1-21
TRACKS	
Adjustment . . . . .	1-26
Installation and Removal . . . . .	1-25
TRANSPORTING THE FELLER BUNCHER	
Procedure . . . . .	1-3

**SERVICE SCHEDULE**

The service schedule is a guide for correct maintenance of the Feller Buncher that must be done regularly. Always use these service intervals unless very hot, cold or dusty operating conditions make it necessary to increase the frequency of service. Failure to do so will cause damage to the Feller Buncher or the engine.

 <b style="font-size: 24pt; margin-left: 10px;">WARNING</b>	<p><b>Never work on loader with lift arms up unless lift arms are held by a lift arm stop. Failure to obey warnings can cause injury or death.</b></p> <p style="text-align: right; font-size: 10pt;">W-2059-0284</p>
--	---

SERVICE SCHEDULE		HOURS					
ITEM	SERVICE REQUIRED	8-10	50	150	250	500	1000
Engine Oil	Check the oil level and add oil as needed.						
Engine Air Cleaner	Check condition indicator. See Page 1–7 for the correct procedure to service the air filter elements.						
Engine Coolant System	Clean debris from cooling fins, shrouds and grills. Check the coolant level.						
Tires	Check for damaged tires and correct air pressure.						
Seat Belt and Seat Bar	Check the condition of seat belt. Inspect the seat bar for correct operation (See Seat Bar System).						
Safety Signs (Decals)	Check for damaged signs (Decals). Replace damaged signs (Decals) and signs (Decals) that are not in the correct location.						
Lift Arm and Cylinder Pivot Points and Shear	Add grease to the fittings (31 places) until extra grease shows.						
Hydraulic/Hydrostatic Fluid	Check the fluid level in the reservoir and add fluid as needed.						
Engine Fuel Filter	Remove water from filter.						
Operator Cab	Check the fastening bolts, washers and nuts. Check the condition of the operator cab.						
Wheel Nuts	★ Check for loose wheel nuts. Tighten to correct torque if loose.						
Hydraulic Fluid, Tubelines and Hoses	Check the fluid level and add as needed. Check for damaged hoses or tubelines and leaks. Replace as needed.						
Alternator Drive Belt	Check tension and adjust as needed.						
Battery	Check water level. Check battery cables for corrosion. Check that the battery cables are tight.						
Engine Oil and Filter	Replace the oil and filter.						
Chaincase	Check fluid level and add as needed.						
Spark Arrestor Muffler	Remove the plug and clean spark chamber.						
Hydraulic/Hydrostatic Filters	△ Replace the filter elements.						
Engine Fuel Filter	Replace the filter element.						
U-Joint	Grease the three (3) fittings with the correct grease.						
Seat Bar	Grease pivots as needed.						
Steering Shaft Pivots	Add oil to steering shaft.						
Hydraulic/Hydrostatic Reservoir	Replace the reservoir breather cap.						
Final Drive Chaincase	Check fluid level by removing the covers. Add fluid as needed.						
Chaincase	Replace the fluid.						
Hydraulic/Hydrostatic Reservoir	Replace the fluid.						
Final Drive Chaincase	Replace the fluid.						

- ★ Check wheel nut torque every 8 hours for the first 24 hours of operation.
- △ Also replace hydrostatic filter element when the transmission warning light stays on for five (5) minutes after the hydrostatic fluid is at operating temperature.

## 1 PREVENTIVE MAINTENANCE

### **WARNING**

Instructions are necessary before doing service on loader. See warnings and instructions both at beginning and throughout this manual. After doing service or making repairs or adjustment, always check function of loader.

Safety glasses or goggles are always needed for eye protection from electric arcs from shorts or welding, battery acid, compressed springs, fluids under pressure, and flying debris or loose material when engines are running or tools are used. Use eye protection approved for type of welding. Failure to obey warnings can cause injury or death.

W-2049-0284

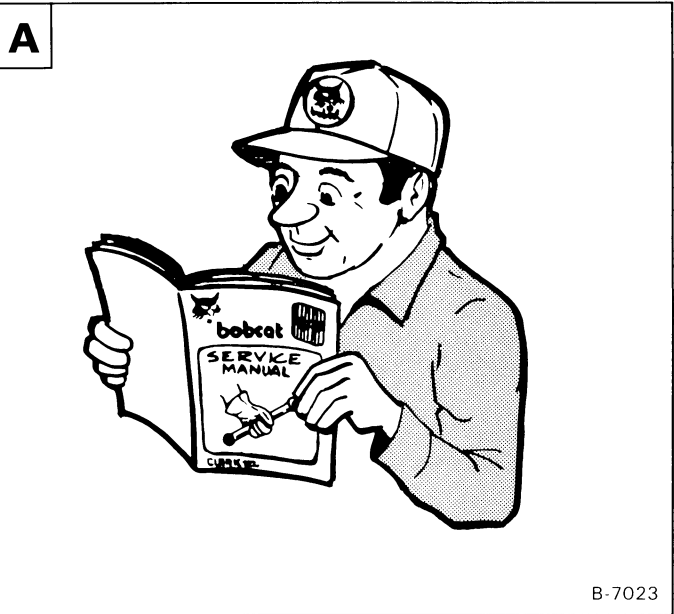

### LIFTING AND BLOCKING THE FELLER BUNCHER

#### Procedure

Always park the Feller Buncher on a level surface.

### **WARNING**

Loader can fall during some service. Put jackstands under both front axles and both rear corners of frame. Failure to obey warnings can cause injury or death.

W-2017-0284

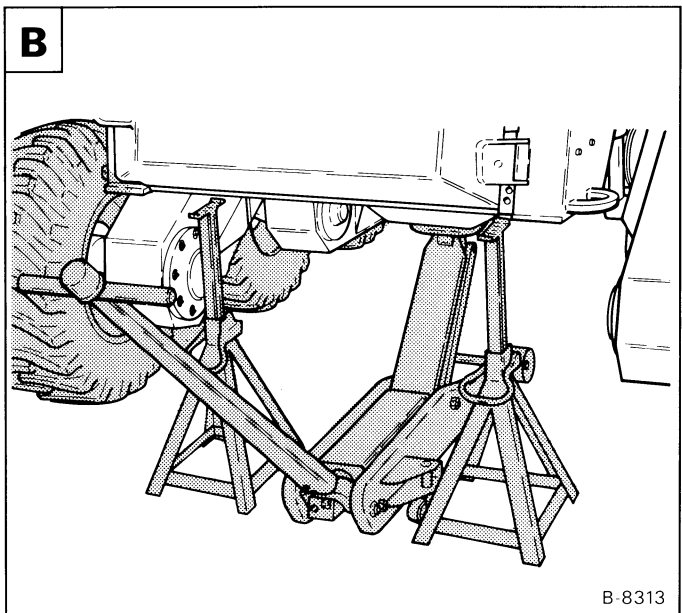

Lower the lift arms, stop the engine.

Put the floor jack under the rear of the Feller Buncher.

Lift the rear of the Feller Buncher and install jackstands **B**.

Put the floor jack under the front of the Feller Buncher.

Lift the front of the Feller Buncher and put jackstands under the axle tubes **C**.

**NOTE:** Make sure the jackstands do not touch the tires.

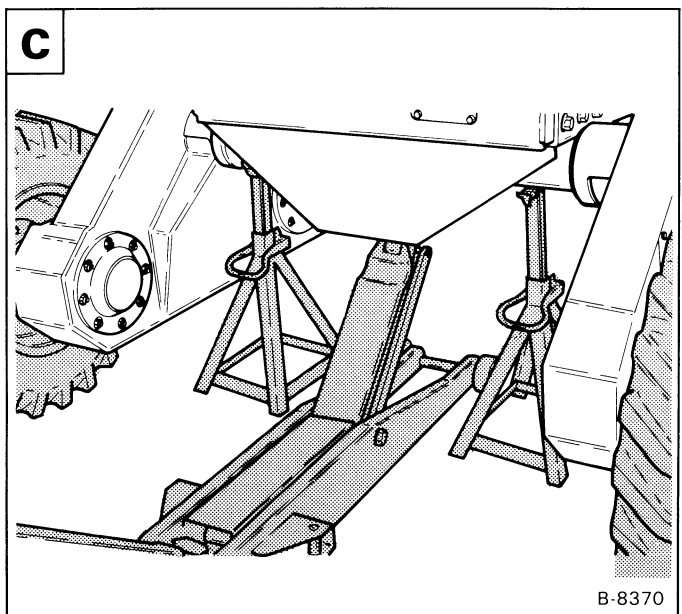

## TRANSPORTING THE FELLER BUNCHER

### Procedure

# WARNING

Use steel loading ramps when moving loader onto a transport vehicle. Do not use wooden planks. Failure to obey warnings can cause injury or death.

W-2058-0284

The Feller Buncher can be loaded forward **A** onto a transport vehicle or backward **B**.

Level the Feller Buncher according to which direction the machine is loaded by raising or lowering the rear of the Feller Buncher.

After the Feller Buncher is loaded onto the transport vehicle, lower the tree shear to the floor.

Engage the parking brake. Lift the seat bar and move the foot pedals until both pedals are locked.

Install chains to hold the Feller Buncher in position to prevent it from moving during sudden stops or goin up and down slopes **C** & **D**.

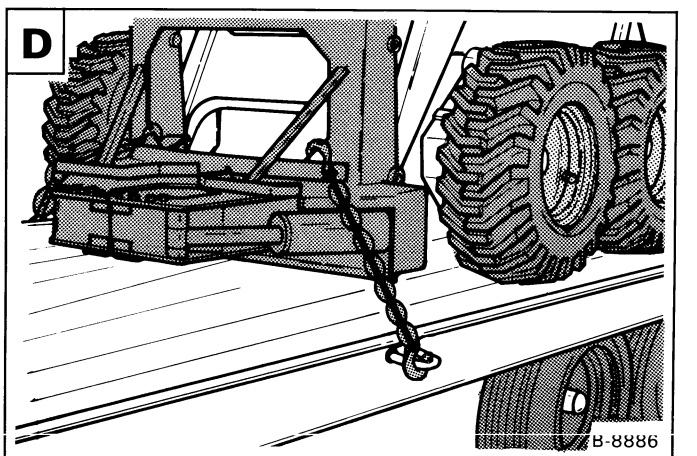
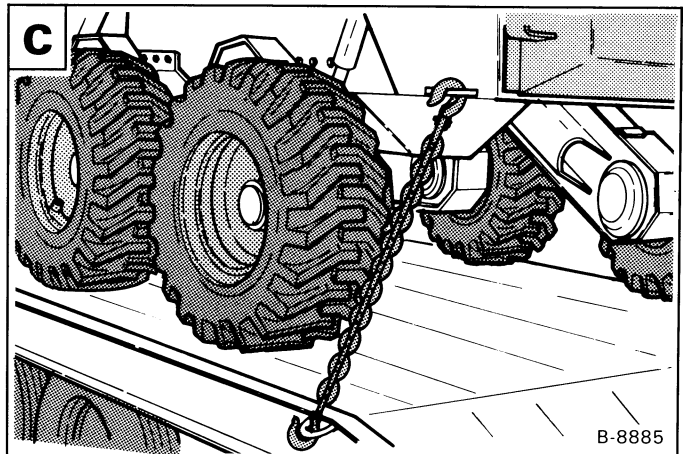
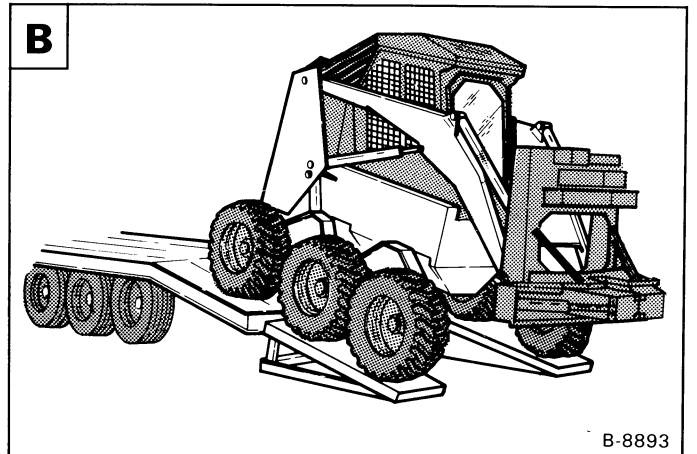
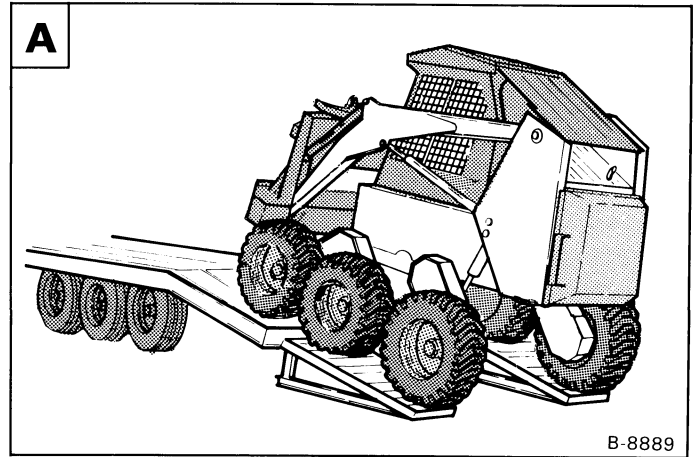

## LIFT ARM STOP

### Procedure

One person must stay in the operator cab with the seat belt fastened and the seat bar lowered, while a second person installs the stop over the rod of one lift cylinder **A**.

Start the engine and raise the lift arms.

Have the second person install the lift arm stop over the rod of one lift cylinder.

The lift arm stop must be tight against the cylinder rod.

Lower the lift arms until the stop is held between the lift arm and the lift cylinder.

## **WARNING**

**Never work on loader with lift arms up unless lift arms are held by a lift arm stop. Failure to obey warnings can cause injury or death.**

W-2059-0284

**A**

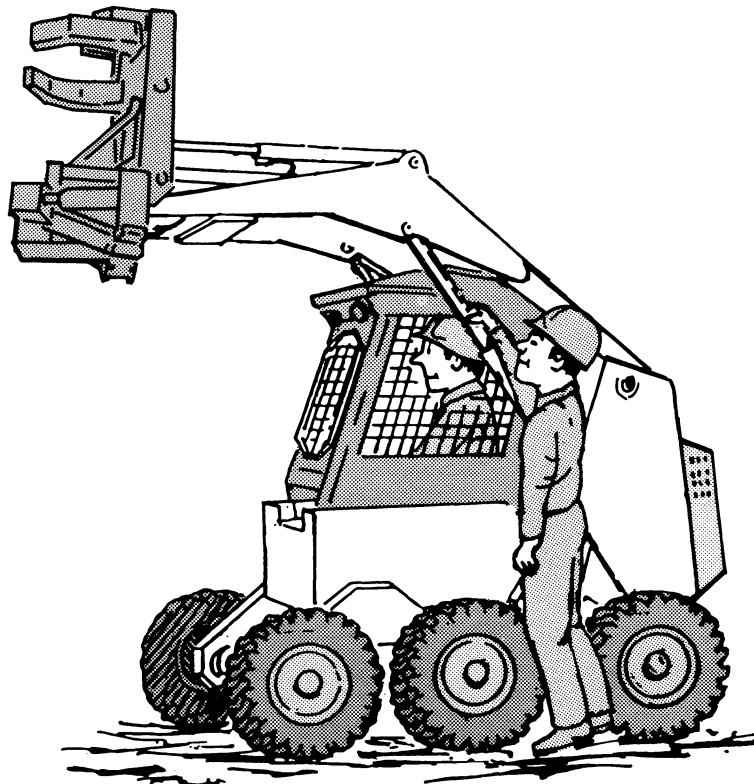

B-8793

## OPERATOR CAB

### Raising the Operator Cab

Stop the Feller Buncher on a level surface. Put the lift arms all the way down.

If the lift arms must be up while raising the cab, install a lift arm stop (See Page 1-4).

Stop the engine and engage the parking brake.

Remove the two fasteners (including the washers or plates) at the front corners of the operator cab **A**.

Two persons are needed to raise the operator cab. Have one person raise the rear window guard over the upright frame.

The second person stands at the front of the operator cab on the safety tread. Lift on the top of the operator cab and grab handle and then lift slowly on the bottom of the operator cab, until it is all the way up **B**.

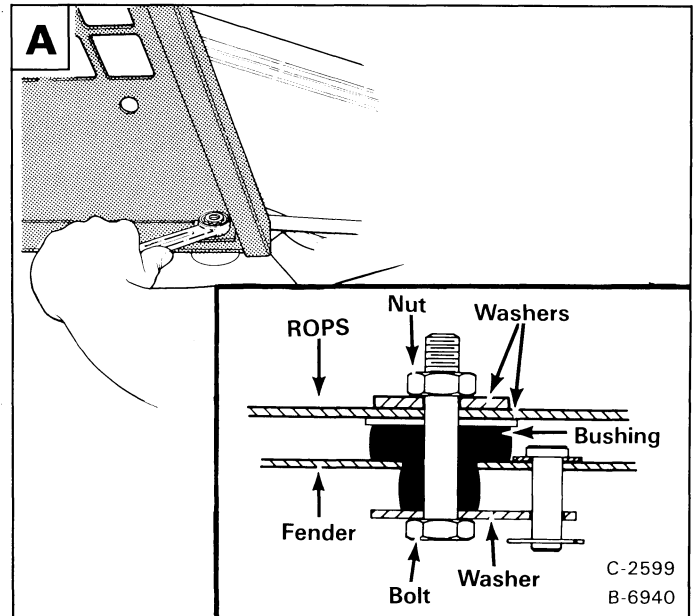

### Lowering the Operator Cab

Two persons are needed to lower the operator cab.

Have one person lift the rear window guard up so it has clearance over the upright frame.

The second person pulls down on the bottom of the cab and slowly lowers it using the grab handle and the top of the operator cab **B**.

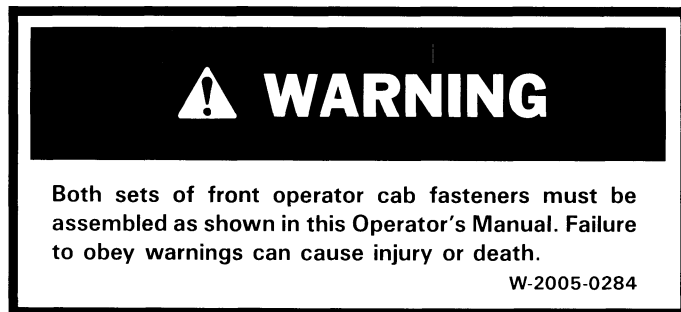

Install the two fasteners (including washers or plate) and tighten the nuts **A**.

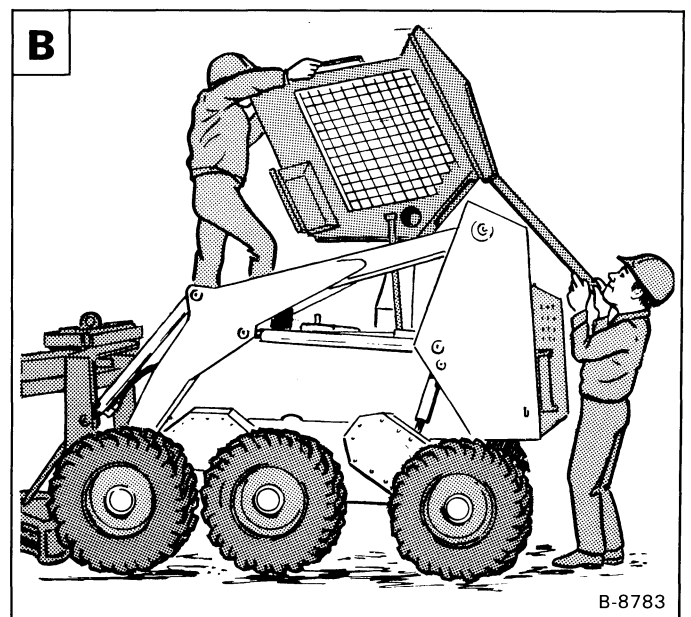

## REAR DOOR

### **! WARNING**

Stop, cool and clean engine of flammable material. Never service or adjust Feller Buncher with engine running unless instructions in manual require engine running. Failure to obey warnins can cause injury or death.

Pull up on the door latch **A**.

Turn the latch to open the rear door **B**.

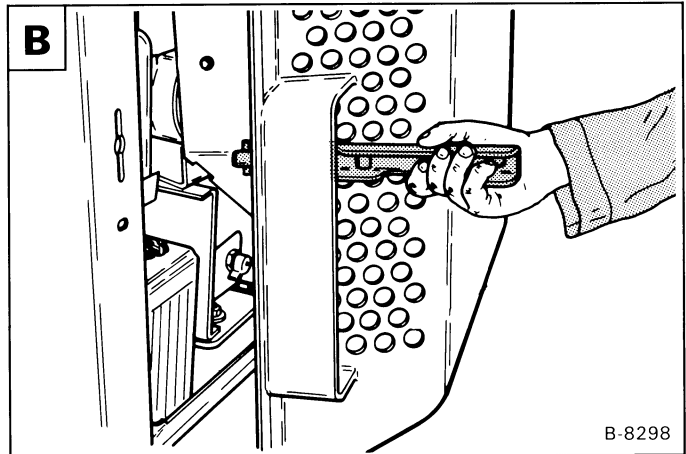
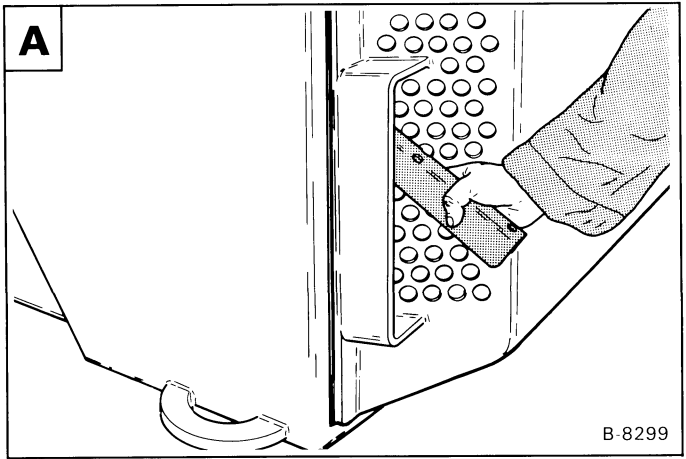

### Door Latch Adjustment

Loosen the set screw **C**.

Loosen the nut **D**.

Turn the bolt (Item 1) in or out until the rear door contacts both the top and bottom of the Feller Buncher frame with the lever in the latched position **D**.

**NOTE:** It takes approximately 50 lbs. of force to push the lever down when the latch is correctly adjusted.

Lubricate the wear surface of the latch.

**NOTE:** With the set screw up, the flanges on the bolt must be to the side so that the set screw aligns with the flat surface at the end of the bolt.

Tighten the set screw **C**.

Tighten the nut to 65 - 70 ft.-lbs. (88 - 95 Nm) torque **D**.

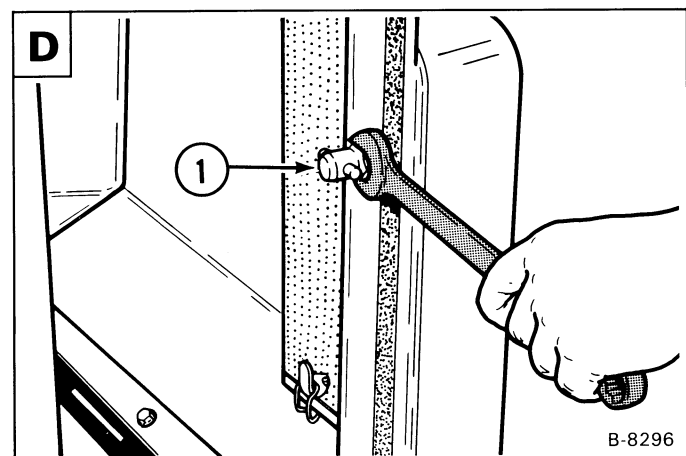
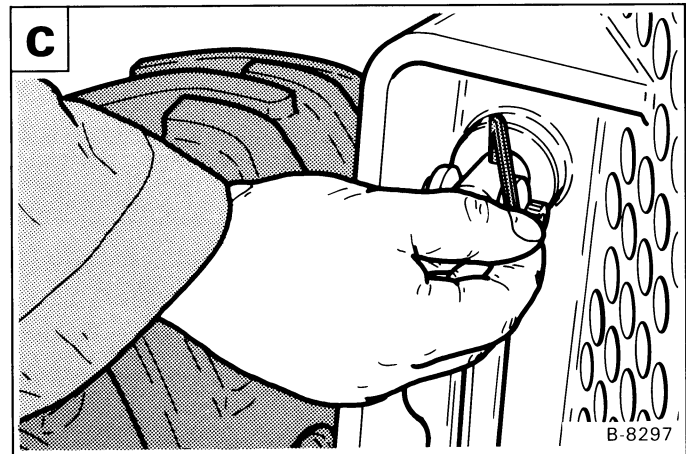

## AIR CLEANER SERVICE

### Filter Element Replacement

See the Service Schedule Page 1—1 for the interval to service the air cleaner system.

**NOTE:** Before changing the air cleaner element, push the button on the condition indicator **A**. Start the engine and if the red ring still shows, do the following procedure.

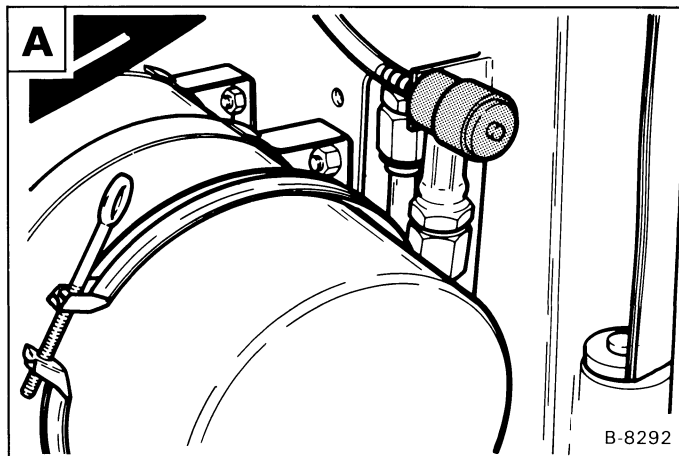

Loosen the clamp and remove the dust cap **B**.

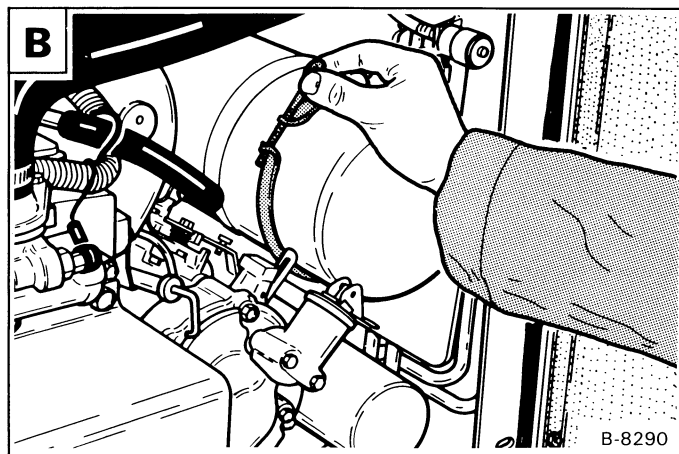

Remove the wing nut and remove the filter element **C**.

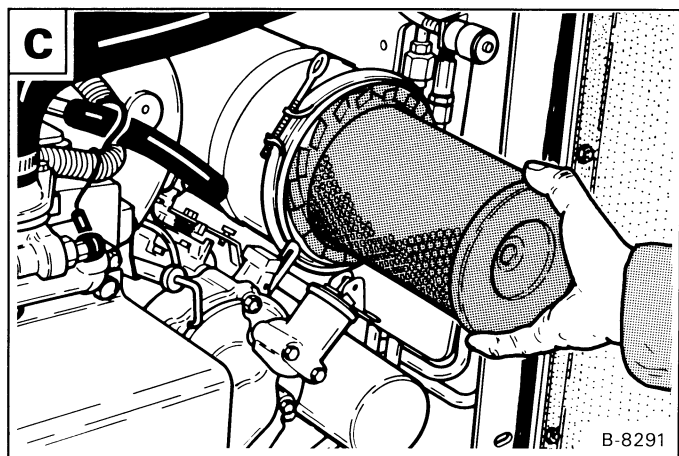

Install the outer filter element. DO NOT replace the inner filter element **D**, unless the red ring still shows (after the engine is running) in the condition indicator window after replacing the outer filter element.

## IMPORTANT

A new filter element must be installed if the old element has been removed.

Install the dust cup and tighten the clamp **B**.

Push the button at the condition indicator to remove the red ring in the window **A**.

Check to make sure clamps at the hose are tight.

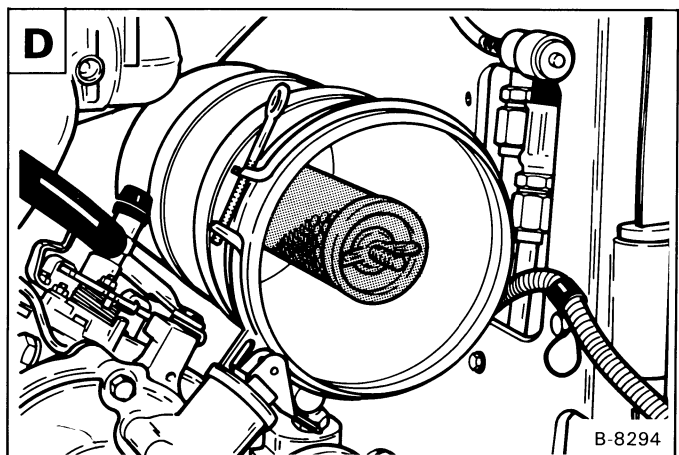

## FUEL SYSTEM

### Filling the Fuel Tank

Use number 2 diesel fuel. During very cold temperatures, use number 1 fuel.

Remove the fuel fill cap **A**.

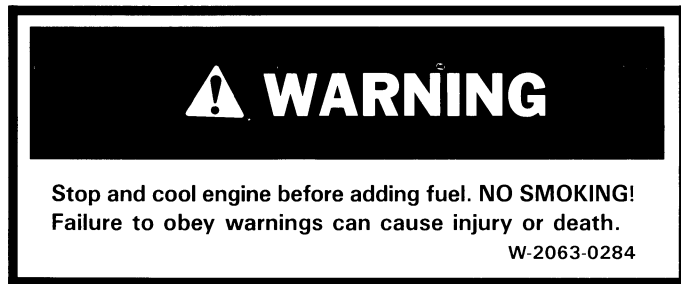
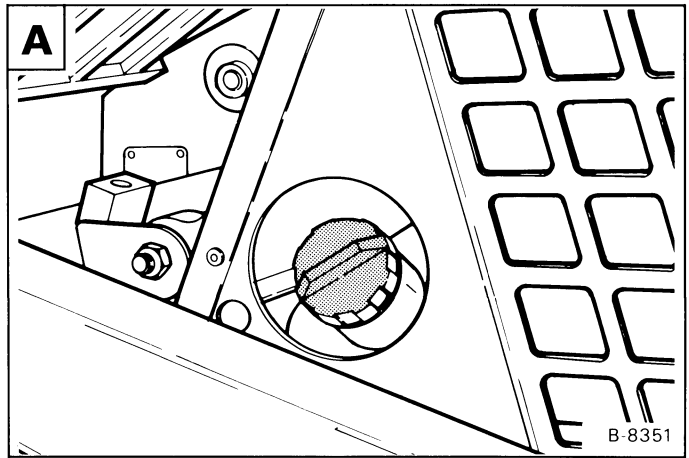

Add fuel as needed using clean fuel of the correct specifications from a clean approved safety container **B**.

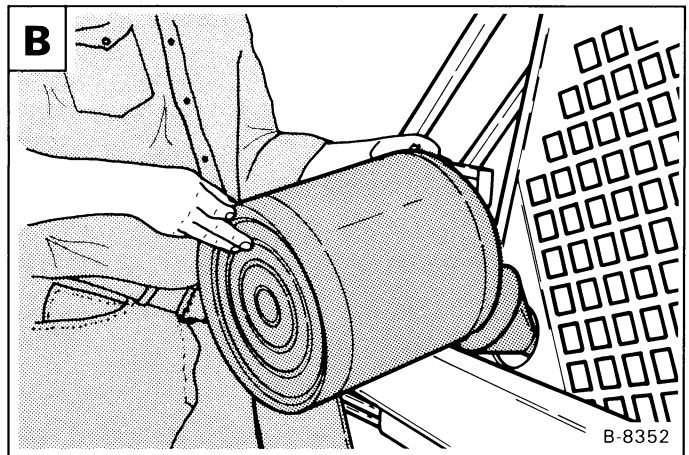

Fill the fuel tank only in an area that has a free movement of air and no open flames or sparks **C**.

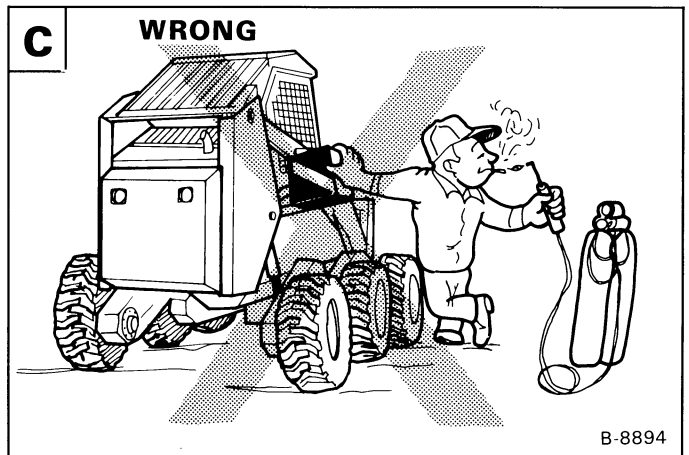

### Removing Water From Fuel Filter

Push up on the spring loaded poppet at the bottom of the fuel filter, until all the water is removed from the filter **D**.

See Section 7, for replacement of the fuel filter element.

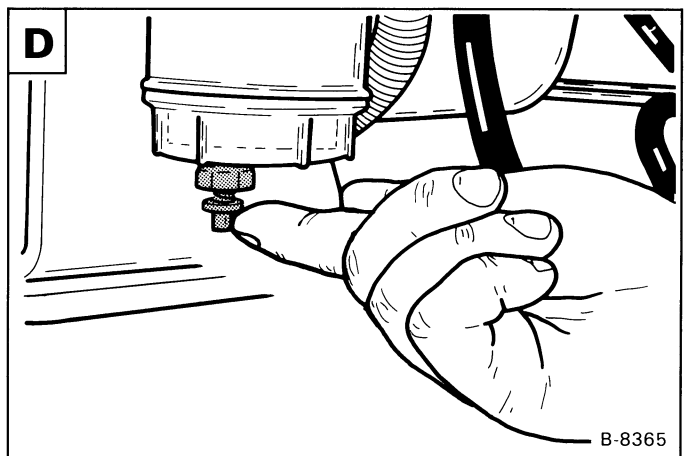

## ENGINE OIL AND FILTER

### Procedure

See the Service Schedule (Page 1-1) for the correct service interval.

Check the oil level every day **A**.

Add the correct oil as needed.

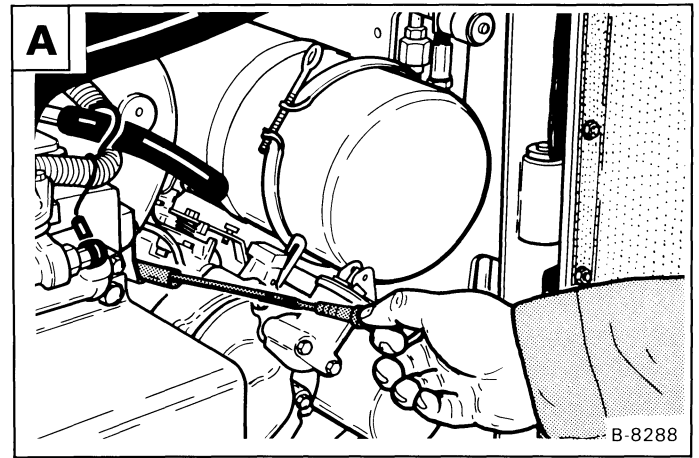

Use recommended engine oil **B**.

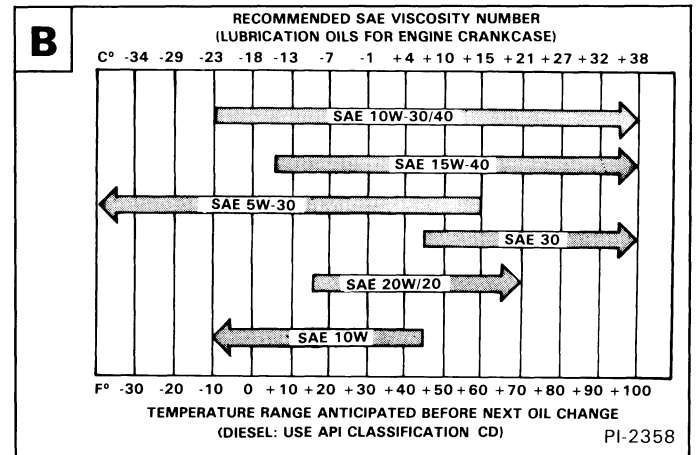

Run the engine until warm. Stop the engine.

Turn the plug at the oil filter housing out about 3 to 5 turns to drain the oil in the filter element into the oil pan **C**.

**NOTE:** This plug must be tightened after oil is removed from the filter element, because if it is not, there will be no engine oil pressure and engine damage will result.

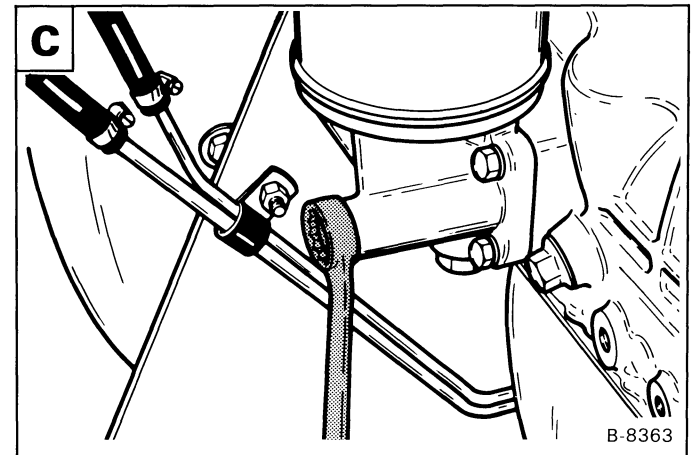

Remove the filter element **D**.

Clean the filter housing surface. Put clean oil on the gasket of the new filter. Install the filter element and hand tighten only.

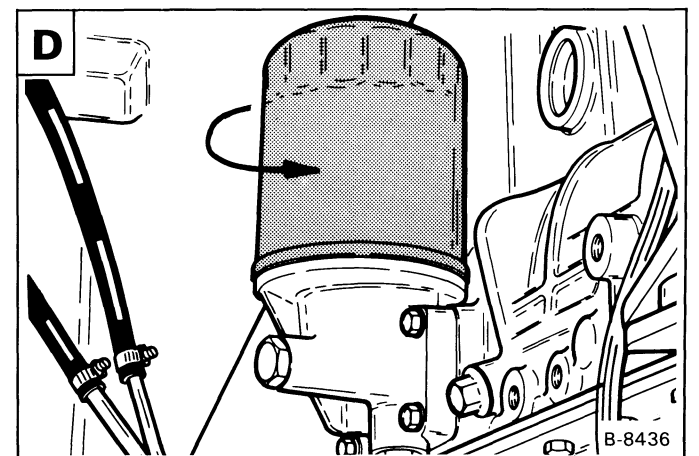

## ENGINE OIL AND FILTER (Cont'd)

Remove the cap at the end of the hose **A**.

Drain the oil into a container.

Install the cap on the end of the hose and tighten **A**.

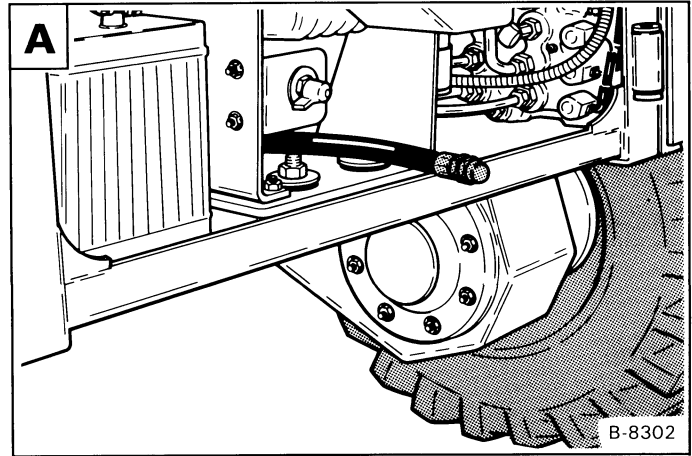

Remove the filler cap **B**.

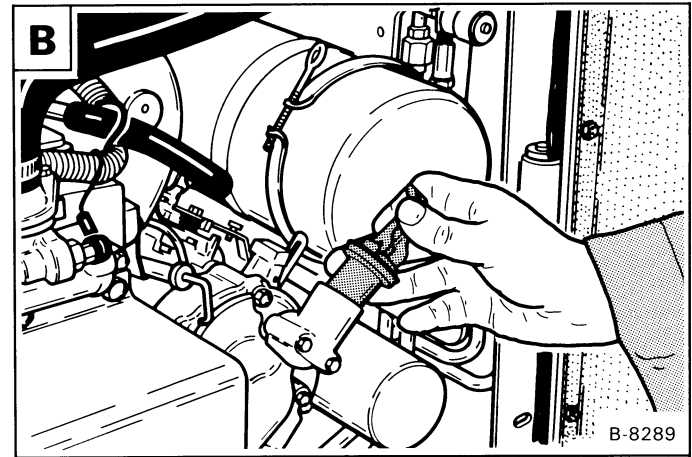

Fill to capacity **C** (See Specification, Section 8).

Start the engine and let it run for about 5 minutes. Check for leaks at the filter.

Stop the engine. Check the oil level.

Add oil until the level is at the "FULL" mark on the dipstick. Install the filter cap **B**.

**NOTE: Do Not overfill the crankcase.**

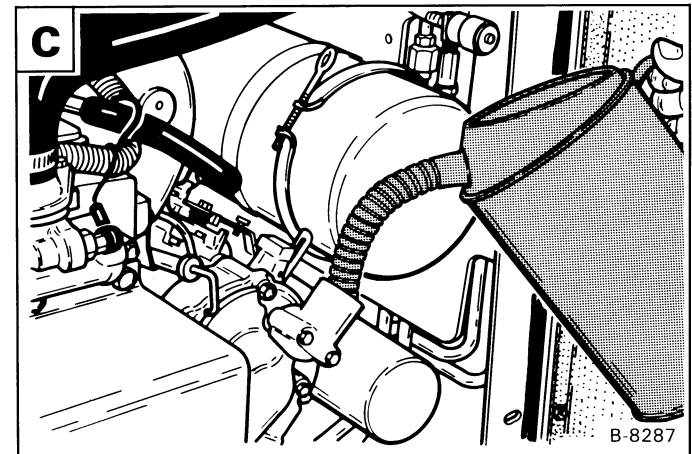



**Suggest:**

**If the above button click is invalid.**

**Please download this document**

**first, and then click the above link**

**to download the complete manual.**

**Thank you so much for reading**

## COOLING SYSTEM

Check the cooling system every day to prevent overheating.

Overheating can cause loss of performance and engine damage.

### Coolant Level

Check the coolant level in the coolant recovery tank **A**.

The level must be 1/3 full when the engine is cool.

Premix coolant before adding to the recovery tank. Use 50% ethylene glycol and 50% water.

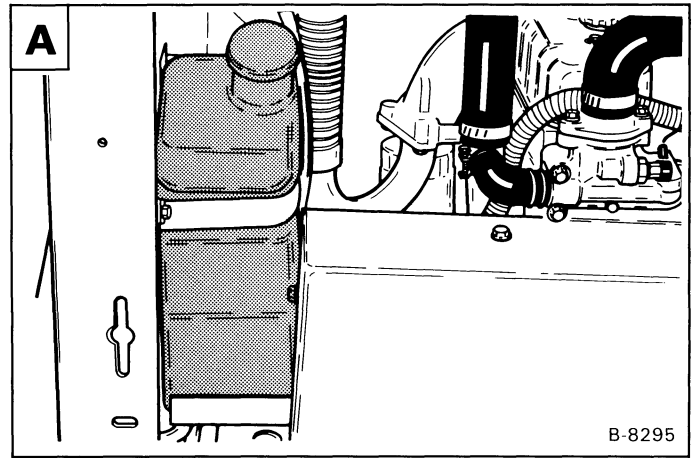

### Cooling System Maintenance

Check for leaks in the cooling system. Check for worn or damaged hoses, clamps or radiator. Check for loose or worn water pump belt.

Use the following procedure to clean the debris from the cooling system.

1. Open the rear door. Remove the covers (top & bottom) from the rear door screens **B**.

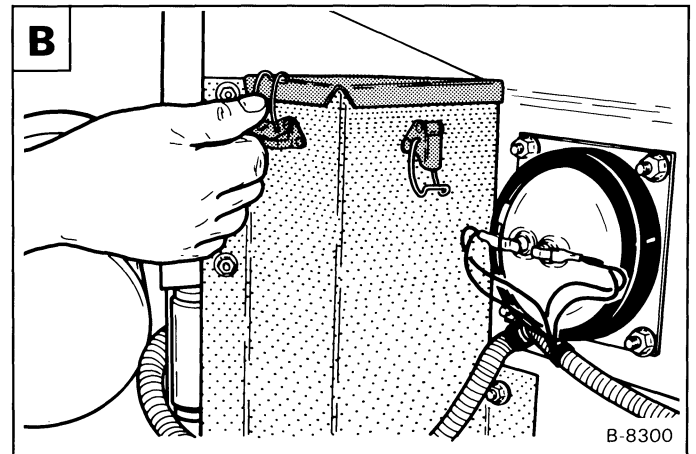

## WARNING

Safety glasses or goggles are always needed for eye protection from fluids under pressure, flying debris or loose material when engine is running or tools are used. Failure to obey warnings can cause injury or death.

W-2019-0284

2. Use air pressure and clean the screens **C**. Install the covers.

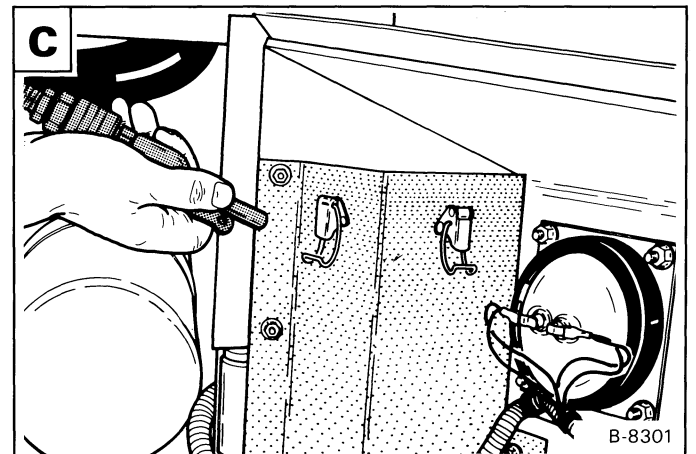

3. Remove the panels above the engine under the oil cooler **D**. Clean the oil cooler area of all debris.

4. Install the panels under the oil cooler **D**.

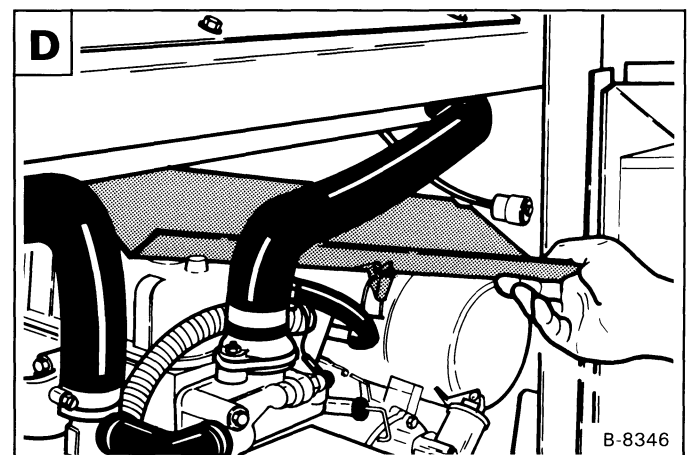

**<https://www.ebooklibonline.com>**

Hello dear friend!

Thank you very much for reading.

Enter the link into your browser.

The full manual is available for immediate download.

**<https://www.ebooklibonline.com>**