

**OPTUM® 270 CVT
OPTUM® 300 CVT
TIER 4B (FINAL)
Tractor**

PIN ZFEM01001 and above

SERVICE MANUAL

Part number 48193162

English

November 2017

© 2017 CNH Industrial Österreich GmbH. All Rights Reserved.

CASE II
AGRICULTURE

Link Product / Engine

Product	Market Product	Engine
OPTUM® 270 CVT - [ZFEM01001 - ZGEM02931]	Middle East Africa	F4DFE617M*B001
OPTUM® 270 CVT - [ZFEM01001 - ZGEM02931]	Asia Pacific	F4DFE617M*B001
OPTUM® 270 CVT - [ZGEM02932 - ZGEM04528]	Middle East Africa	F4DFE617M*B001
OPTUM® 270 CVT - [ZGEM02932 - ZGEM04528]	Asia Pacific	F4DFE617M*B001
OPTUM® 270 CVT - [ZGEM04529 -]	Middle East Africa	F4DFE617M*B001
OPTUM® 270 CVT - [ZGEM04529 -]	Asia Pacific	F4DFE617M*B001
OPTUM® 270 CVT - [ZFEM50001 - ZGEM50841]	Asia Pacific	F4DFE617M*B001
OPTUM® 270 CVT - [ZFEM50001 - ZGEM50841]	Middle East Africa	F4DFE617M*B001
OPTUM® 270 CVT - [ZFEM50001 - ZGEM50841]	Australia New Zealand	F4DFE617M*B001
OPTUM® 270 CVT - [ZGEM50842 - ZGEM51829]	Australia New Zealand	F4DFE617M*B001
OPTUM® 270 CVT - [ZGEM50842 - ZGEM51829]	Asia Pacific	F4DFE617M*B001
OPTUM® 270 CVT - [ZGEM50842 - ZGEM51829]	Middle East Africa	F4DFE617M*B001
OPTUM® 270 CVT - [ZGEM51830 -]	Middle East Africa	F4DFE617M*B001
OPTUM® 270 CVT - [ZGEM51830 -]	Australia New Zealand	F4DFE617M*B001
OPTUM® 270 CVT - [ZGEM51830 -]	Asia Pacific	F4DFE617M*B001
OPTUM® 300 CVT - [ZFEM01001 - ZGEM02931]	Asia Pacific	F4DFE617L*B002
OPTUM® 300 CVT - [ZFEM01001 - ZGEM02931]	Middle East Africa	F4DFE617L*B002
OPTUM® 300 CVT - [ZGEM02932 - ZGEM04528]	Middle East Africa	F4DFE617L*B002
OPTUM® 300 CVT - [ZGEM02932 - ZGEM04528]	Asia Pacific	F4DFE617L*B002
OPTUM® 300 CVT - [ZGEM04529 -]	Middle East Africa	F4DFE617L*B002
OPTUM® 300 CVT - [ZGEM04529 -]	Asia Pacific	F4DFE617L*B002
OPTUM® 300 CVT - [ZFEM50001 - ZGEM50841]	Asia Pacific	F4DFE617L*B002
OPTUM® 300 CVT - [ZFEM50001 - ZGEM50841]	Middle East Africa	F4DFE617L*B002
OPTUM® 300 CVT - [ZFEM50001 - ZGEM50841]	Australia New Zealand	F4DFE617L*B002

Product	Market Product	Engine
OPTUM® 300 CVT - [ZGEM50842 - ZGEM51829]	Middle East Africa	F4DFE617L*B002
OPTUM® 300 CVT - [ZGEM50842 - ZGEM51829]	Australia New Zealand	F4DFE617L*B002
OPTUM® 300 CVT - [ZGEM50842 - ZGEM51829]	Asia Pacific	F4DFE617L*B002
OPTUM® 300 CVT - [ZGEM51830 -]	Australia New Zealand	F4DFE617L*B002
OPTUM® 300 CVT - [ZGEM51830 -]	Asia Pacific	F4DFE617L*B002
OPTUM® 300 CVT - [ZGEM51830 -]	Middle East Africa	F4DFE617L*B002

<https://www.ebooklibonline.com>

Hello dear friend!

Thank you very much for reading.

Enter the link into your browser.

The full manual is available for immediate download.

<https://www.ebooklibonline.com>

Contents

INTRODUCTION

Engine.....	10
[10.001] Engine and crankcase	10.1
[10.216] Fuel tanks	10.2
[10.202] Air cleaners and lines	10.3
[10.254] Intake and exhaust manifolds and muffler	10.4
[10.500] Selective Catalytic Reduction (SCR) exhaust treatment	10.5
[10.400] Engine cooling system	10.6
[10.414] Fan and drive	10.7
[10.310] Aftercooler.....	10.8
Clutch	18
[18.112] Slip clutch or flywheel damper	18.1
Transmission.....	21
[21.504] Continuously Variable Transmission (CVT)	21.1
[21.505] Continuously Variable Transmission (CVT) external controls.....	21.2
[21.506] Continuously Variable Transmission (CVT) hydraulic components	21.3
[21.507] Continuously Variable Transmission (CVT) internal components.....	21.4
Four-Wheel Drive (4WD) system	23
[23.202] Electro-hydraulic control	23.1
[23.314] Drive shaft.....	23.2
Front axle system	25
[25.100] Powered front axle	25.1
[25.102] Front bevel gear set and differential	25.2
[25.108] Final drive hub, steering knuckles, and shafts	25.3
[25.122] Axle suspension control.....	25.4
Rear axle system.....	27

[27.100] Powered rear axle	27.1
[27.106] Rear bevel gear set and differential	27.2
[27.120] Planetary and final drives	27.3
Power Take-Off (PTO)	31
[31.104] Rear electro-hydraulic control	31.1
[31.119] Four-speed rear Power Take-Off (PTO)	31.2
[31.142] Front Power Take-Off (PTO) control	31.3
[31.146] Front Power Take-Off (PTO)	31.4
Brakes and controls	33
[33.202] Hydraulic service brakes	33.1
[33.110] Parking brake or parking lock	33.2
[33.240] Emergency brake	33.3
[33.220] Trailer brake hydraulic control	33.4
[33.224] Trailer brake pneumatic control	33.5
[33.204] Front axle brake	33.6
[33.200] Brake cooling	33.7
[33.350] Anti-lock Brake System (ABS)	33.8
Hydraulic systems	35
[35.000] Hydraulic systems	35.1
[35.300] Reservoir, cooler, and filters	35.2
[35.106] Variable displacement pump	35.3
[35.230] Priority valves	35.4
[35.204] Remote control valves	35.5
[35.220] Auxiliary hydraulic pump	35.6
[35.114] Three-point hitch control valve	35.7
[35.116] Three-point hitch cylinder	35.8
[35.124] Three-point hitch hydraulic adjustment	35.9
[35.160] Front hitch controls and lines	35.10

[35.162] Front hitch cylinders and lines	35.11
Hitches, drawbars, and implement couplings.....	37
[37.100] Drawbars and towing hitches	37.1
[37.106] Automatic pickup hitch	37.2
[37.162] Front hitch	37.3
Frames and ballasting	39
[39.100] Frame	39.1
[39.140] Ballasts and supports	39.2
Steering.....	41
[41.101] Steering control	41.1
[41.106] Tie rods.....	41.2
[41.200] Hydraulic control components.....	41.3
[41.216] Cylinders	41.4
[41.432] Autoguidance steering	41.5
Wheels	44
[44.511] Front wheels.....	44.1
[44.520] Rear wheels.....	44.2
Cab climate control	50
[50.100] Heating.....	50.1
[50.104] Ventilation	50.2
[50.200] Air conditioning	50.3
Electrical systems.....	55
[55.045] Front axle control system	55.1
[55.000] Electrical system	55.2
[55.100] Harnesses and connectors.....	55.3
[55.015] Engine control system.....	55.4
[55.301] Alternator	55.5

[55.302] Battery.....	55.6
[55.988] Selective Catalytic Reduction (SCR) electrical system	55.7
[55.640] Electronic modules	55.8
[55.513] Cab transmission controls.....	55.9
[55.024] Transmission control system	55.10
[55.020] Transmission speed sensors.....	55.11
[55.021] Transmission pressure sensors	55.12
[55.022] Transmission temperature sensors	55.13
[55.023] Transmission position sensors and switches	55.14
[55.048] Rear Power Take-Off (PTO) control system	55.15
[55.049] Front Power Take-Off (PTO) control system	55.16
[55.519] Cab brake controls	55.17
[55.031] Parking brake electrical system	55.18
[55.512] Cab controls.....	55.19
[55.035] Remote control valve electric control	55.20
[55.051] Cab Heating, Ventilation, and Air-Conditioning (HVAC) controls.....	55.21
[55.050] Heating, Ventilation, and Air-Conditioning (HVAC) control system.....	55.22
[55.047] Steering control system	55.23
[55.130] Rear three-point hitch electronic control system	55.24
[55.160] Front hitch electronic control system.....	55.25
[55.911] Satellite navigation systems.....	55.26
[55.404] External lighting	55.27
[55.510] Cab or platform harnesses and connectors.....	55.28
[55.408] Warning indicators, alarms, and instruments	55.29
[55.550] Tire Pressure Monitoring System (TPMS)	55.30
[55.350] Anti-lock Brake System (ABS) electrical system.....	55.31
[55.DTC] FAULT CODES.....	55.32
Platform, cab, bodywork, and decals.....	90
[90.150] Cab.....	90.1

[90.156] Cab windshield and windows 90.2
[90.100] Engine hood and panels 90.3



INTRODUCTION

Contents

INTRODUCTION

Foreword - How to use and navigate through this manual	3
Foreword - Important notice regarding equipment servicing	8
Torque	9
Torque - Standard torque data for hydraulic connections	14
Capacities	21
Consumables	22

Foreword - How to use and navigate through this manual

This manual has been produced by a new technical information system. This new system is designed to deliver technical information electronically through web delivery (eTIM), DVD, and paper manuals. A coding system called SAP has been developed to link the technical information to other Product Support functions, e.g., Warranty.

Technical information is written to support the maintenance and service of the functions or systems on a customer's machine. When a customer has a concern on their machine it is usually because a function or system on their machine is not working at all, is not working efficiently, or is not responding correctly to their commands. When you refer to the technical information in this manual to resolve that customer's concern, you will find all the information classified using the SAP coding, according to the functions or systems on that machine. Once you have located the technical information for that function or system, you will then find all the mechanical, electrical or hydraulic devices, components, assemblies, and sub assemblies for that function or system. You will also find all the types of information that have been written for that function or system: the technical data (specifications), the functional data (how it works), the diagnostic data (fault codes and troubleshooting), and the service data (remove, install adjust, etc.).

By integrating SAP coding into technical information, you will be able to search and retrieve just the right piece of technical information you need to resolve that customer's concern on his machine. This is made possible by attaching 3 categories to each piece of technical information during the authoring process.

The first category is the Location, the second category is the Information Type and the third category is the Product:

- LOCATION - the component or function on the machine, that the piece of technical information is going to describe (e.g., Fuel tank).
- INFORMATION TYPE - the piece of technical information that has been written for a particular component or function on the machine (e.g., Capacity would be a type of Technical Data describing the amount of fuel held by the fuel tank).
- PRODUCT - the model for which the piece of technical information is written.

Every piece of technical information will have those three categories attached to it. You will be able to use any combination of those categories to find the right piece of technical information you need to resolve that customer's concern on their machine.

That information could be:

- the procedure for how to remove the cylinder head
- a table of specifications for a hydraulic pump
- a fault code
- a troubleshooting table
- a special tool



SERVICE MANUAL

Engine

OPTUM® 270 CVT - [ZFEM01001 - ZGEM02931], OPTUM® 270 CVT - [ZFEM50001 - ZGEM50841], OPTUM® 270 CVT - [ZGEM02932 - ZGEM04528], OPTUM® 270 CVT - [ZGEM04529 -], OPTUM® 270 CVT - [ZGEM50842 - ZGEM51829], OPTUM® 270 CVT - [ZGEM51830 -], OPTUM® 300 CVT - [ZFEM01001 - ZGEM02931], OPTUM® 300 CVT - [ZFEM50001 - ZGEM50841], OPTUM® 300 CVT - [ZGEM02932 - ZGEM04528], OPTUM® 300 CVT - [ZGEM04529 -], OPTUM® 300 CVT - [ZGEM50842 - ZGEM51829], OPTUM® 300 CVT - [ZGEM51830 -]

Engine - Remove

Prior operation:

Separate the front axle and front frame from the engine, see **Front frame - Remove (39.100)**.

Prior operation:

Remove the left-hand fuel tank, see **Fuel tank - Remove (10.216)**.

Prior operation:

Remove the selective catalytic reduction (SRC) muffler, see **Selective Catalytic Reduction (SCR) muffler and catalyst - Remove (10.500)**.

Prior operation:

Remove the engine hood, see **Hood - Remove (90.100)**.

⚠ WARNING

Heavy objects!

Lift and handle all heavy components using lifting equipment with adequate capacity. Always support units or parts with suitable slings or hooks. Make sure the work area is clear of all bystanders.

Failure to comply could result in death or serious injury.

W0398A

⚠ WARNING

Avoid injury!

Handle all parts carefully. Do not place your hands or fingers between parts. Use Personal Protective Equipment (PPE) as indicated in this manual, including protective goggles, gloves, and safety footwear.

Failure to comply could result in death or serious injury.

W0208A

1. Remove the starter motor shield.

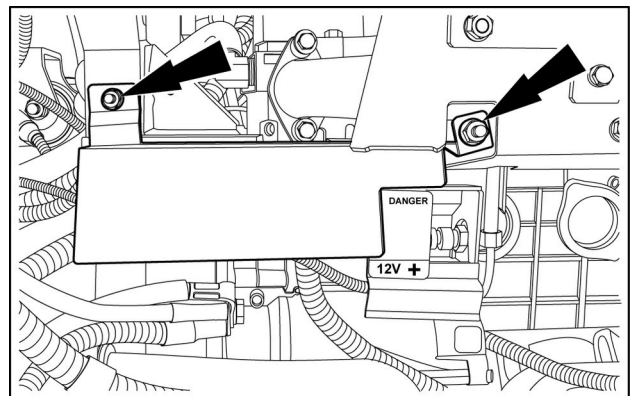

BAIL15TR00891AA 1

2. Remove the positive cable cover.

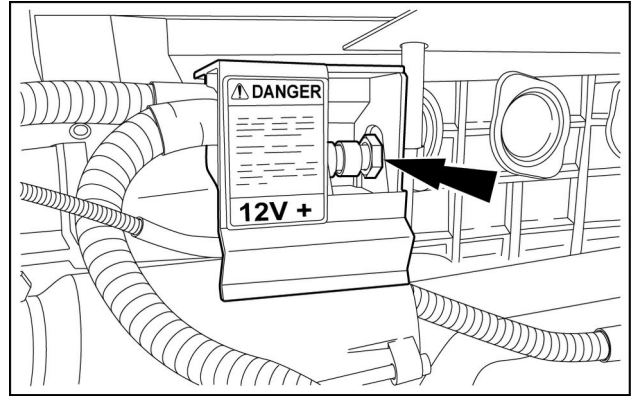

BAIL15TR00892AA 2

3. Disconnect the positive connectors.

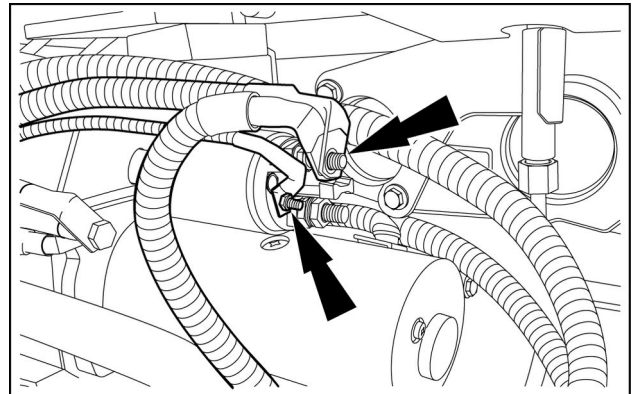

BAIL15TR00877AA 3

4. Disconnect the ground connectors.

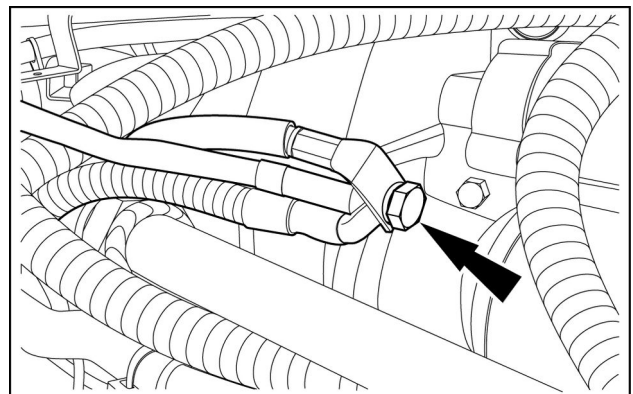

BAIL15TR00893AA 4

5. • Disconnect the grid heater relay electrical connector (1).
• Cut the cable ties (2).

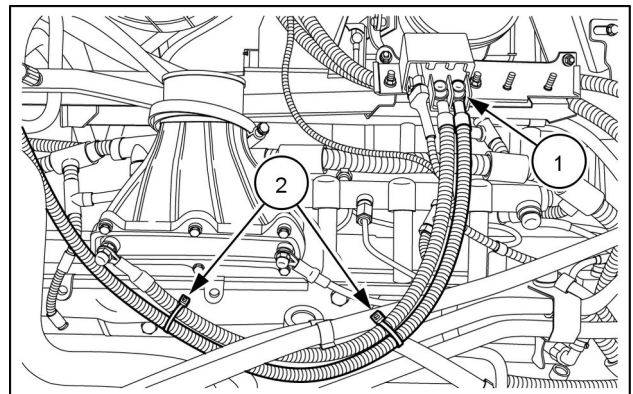

BAIL15TR00878AA 5

6. • Detach the wiring harness retaining bracket (1).
• Detach the fuse box (2).

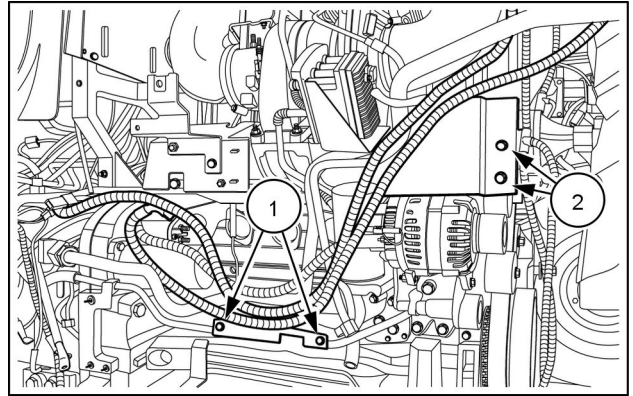

BAIL15TR00879AA 6

7. Disconnect the alternator positive cable.

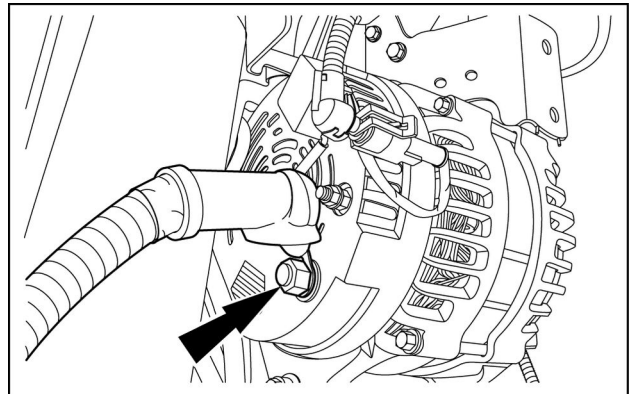

BAIL15TR00880AA 7

8. • Disconnect the compressor coolant hose (1).
• Detach the oil cooler pipe retaining bracket (2).
• Disconnect the oil cooler pipe (3).

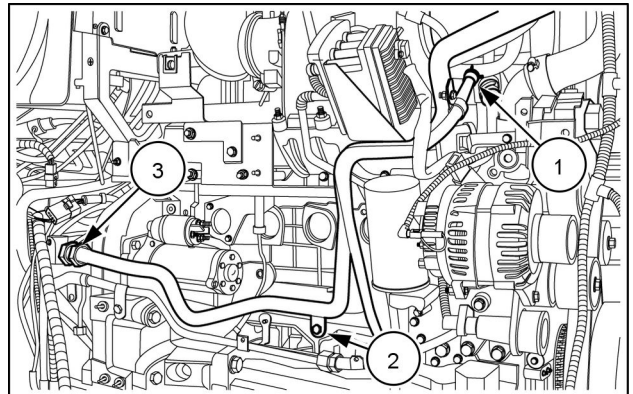

BAIL15TR00881AA 8

9. 1. Disconnect the coolant pipe connectors (1).
2. Detach the coolant pipe retaining brackets (2).

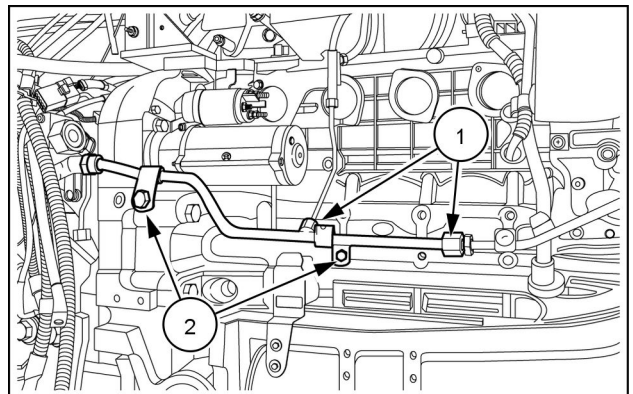

BAIL15TR00882AA 9

10. Disconnect the coolant hose from the rear of the cylinder head.

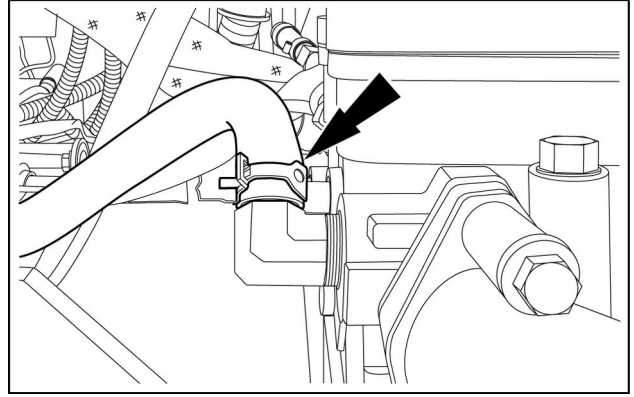

BAIL15TR00883AA 10

11. Disconnect the alternator electrical connector.

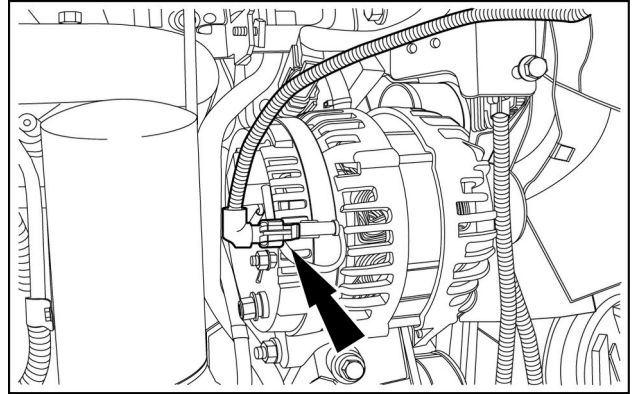

BAIL15TR00884AA 11

12. Disconnect the air intake sensor electrical connector.

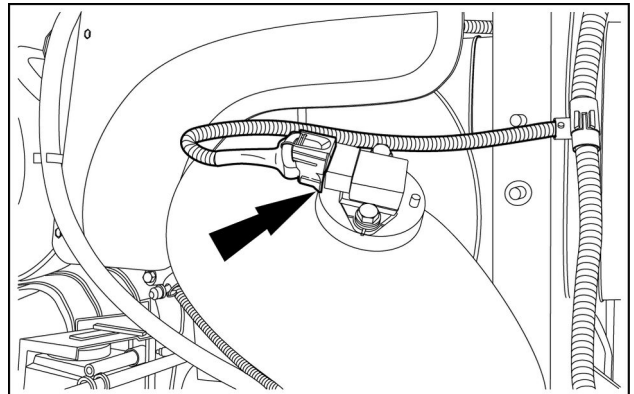

BAIL15TR00885AA 12

13. Remove the left-hand oil cooler pipe:
 - A. Disconnect the hydraulic pipe (1).
 - B. Detach the hydraulic pipe retaining bracket (2).

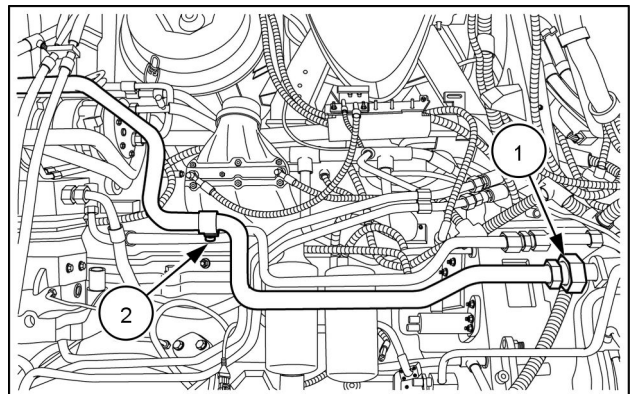

BAIL15TR00886AA 13

14. Remove the air compressor outlet pipe:
- A. Disconnect the air compressor banjo connector **(1)**.
 - B. Disconnect the in-line connector **(2)**.
 - C. Detach the pipe retaining bracket **(3)**.

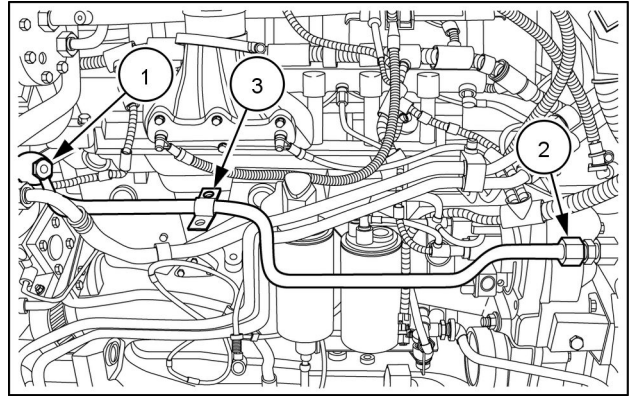

BAIL15TR00887AA 14

15. 1. Disconnect the ground connections **(1)**.
2. Disconnect the steering motor hoses **(2)**.
3. Detach the steering pipe retaining bracket **(3)**.

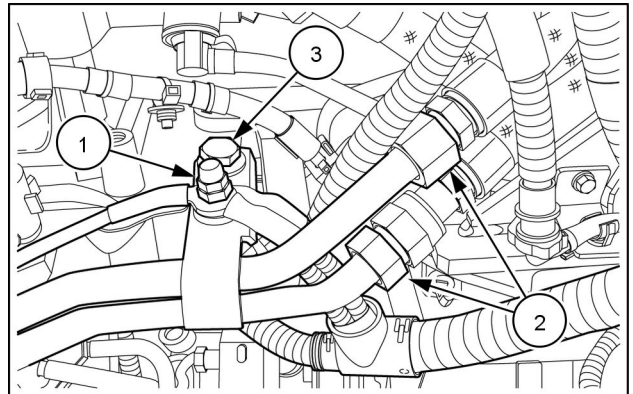

BAIL15TR00888AA 15

16. Disconnect the water in fuel sensor electrical connector.

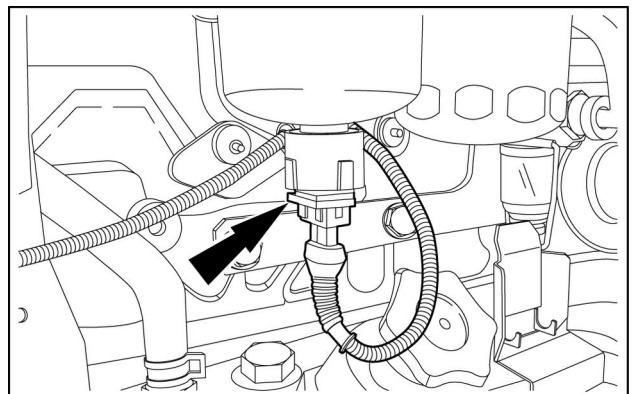

BAIL15TR00889AA 16

17. Disconnect the fuel line from the water trap.

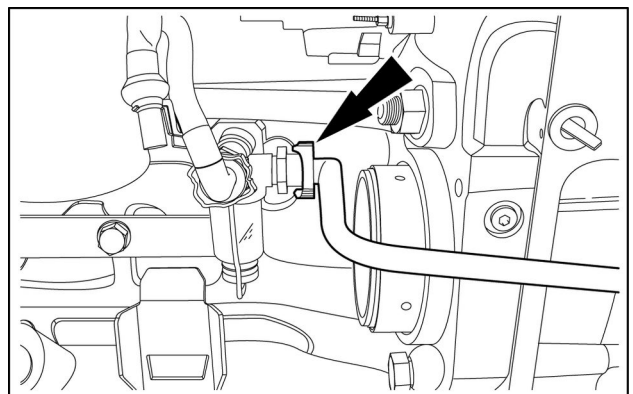

BAIL15TR00890AA 17

18. 1. Disconnect the grid heater relay electrical connectors (1).
2. Detach the grid heater relay bracket (2).

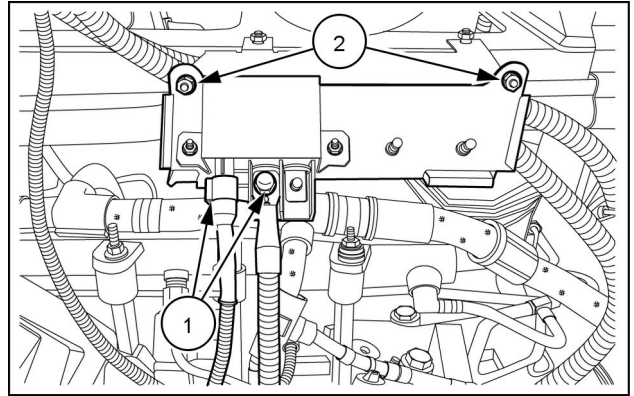

BAIL15TR00898AA 18

19. Remove the fuel lines:
 - Disconnect the in-line connectors (1).
 - Detach the fuel lines from the clips (2).
 - Cut the cable tie (3).

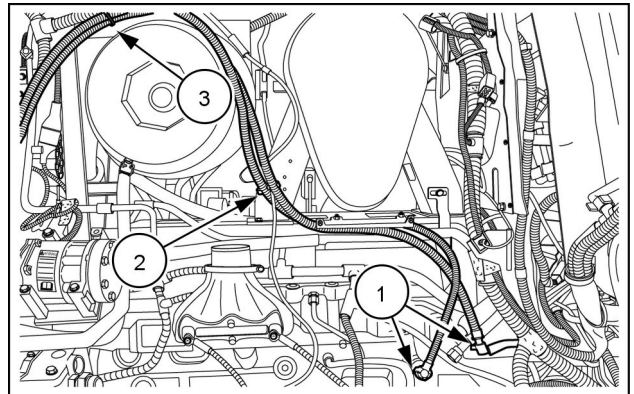

BAIL15TR00899AA 19

20. Disconnect the flywheel speed sensor electrical connector.

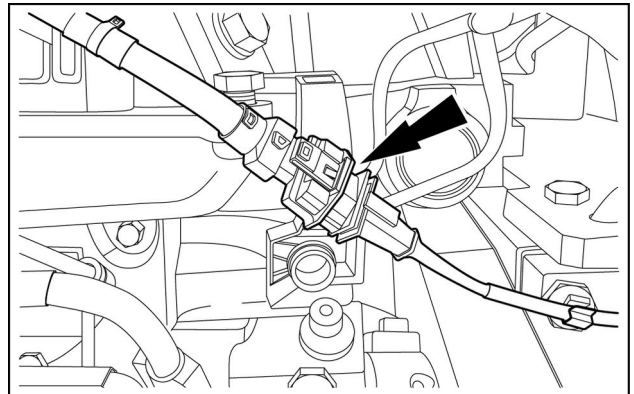

BAIL15TR00900AA 20

21. Disconnect the engine wiring harness in-line electrical connector.

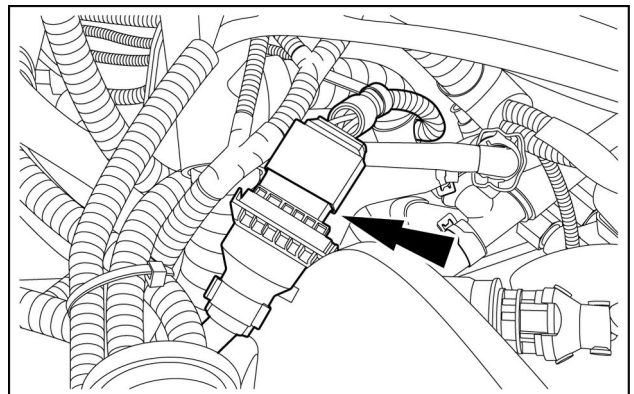

BAIL15TR00896AA 21

22. 1. Disconnect the A/C compressor return pipe (1).
2. Disconnect the A/C high pressure pipe in-line connector (2).
3. Detach the A/C pipe retaining bracket (3).

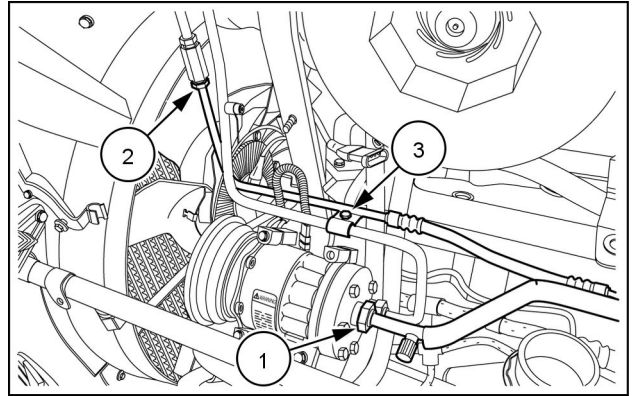

BAIL15TR00897AA 22

23. 1. Cut the cable tie (1).
2. Disconnect the A/C compressor clutch electrical connector (2).

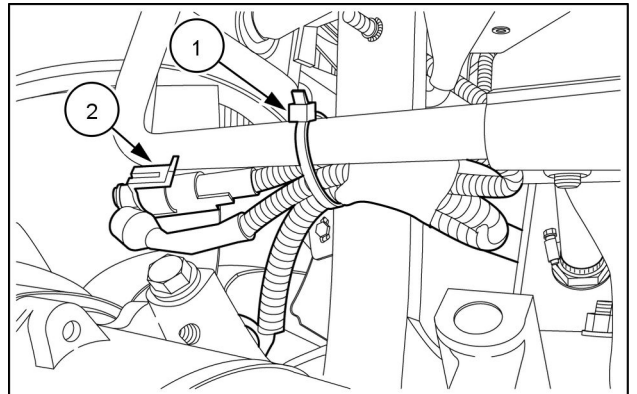

BAIL15TR01177AA 23

24. Disconnect the viscous fan electrical connector.

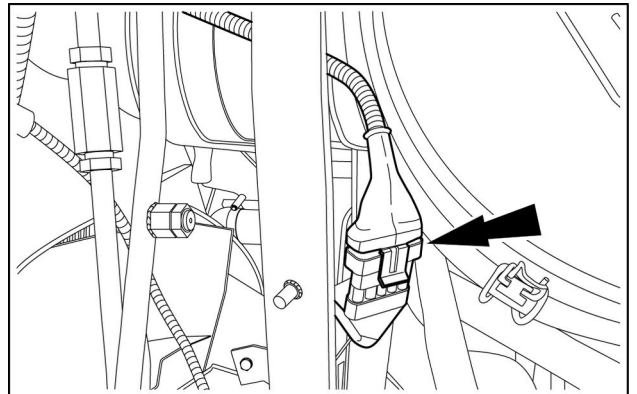

BAIL15TR01178AA 24

25. Disconnect the coolant expansion tank electrical connectors.

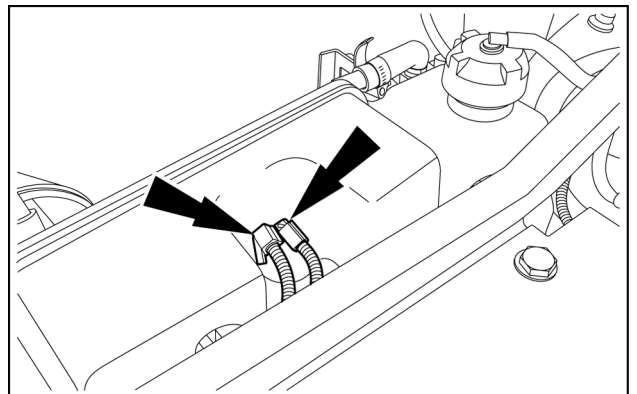

BAIL15TR00894AA 25

26. Disconnect the NO_x sensor module electrical connector.

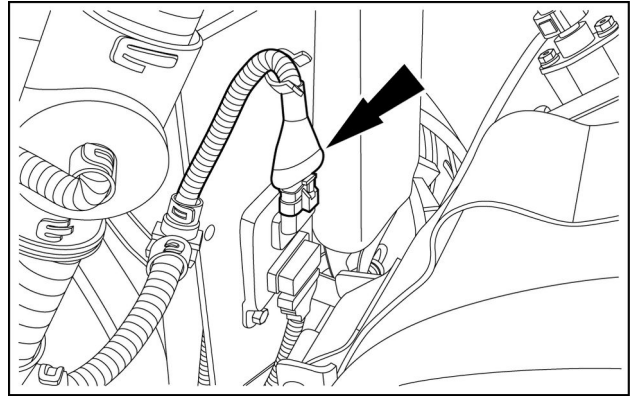

BAIL15TR00895AA 26

27. 1. Disconnect the **DIESEL EXHAUST FLUID (DEF)/ AdBLUE®** dosing module lines (1).

NOTE: Seal all openings with clean blanking plugs.

2. Disconnect the **DEF/AdBLUE®** dosing module electrical connector (2).

NOTICE: Avoid **DEF/AdBLUE®** contamination of the electrical connector by disconnecting the **DEF/AdBLUE®** connectors first.

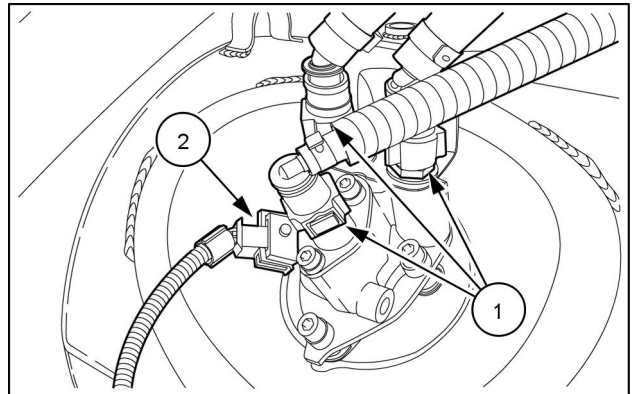

BAIL15TR01273AA 27

28. • Detach the wiring harness (1).
• Cut the cable tie (2).
• Disconnect the in-line electrical connector (3).

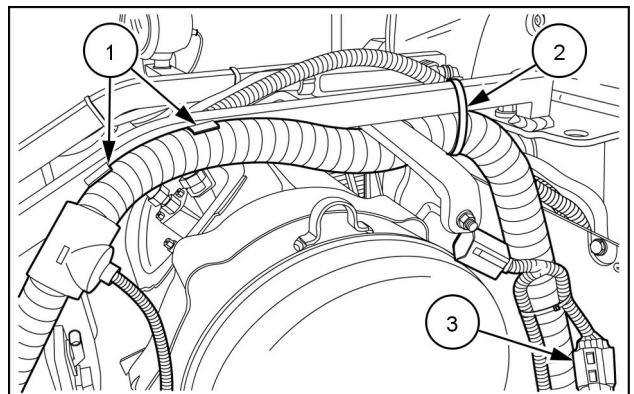

BAIL15TR00904AA 28

29. Disconnect the Diesel Oxidation Catalyst (DOC) temperature sensor electrical connector.

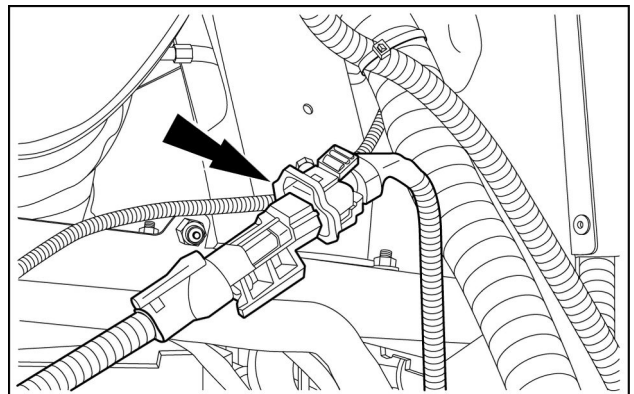

BAIL15TR00905AA 29

30. Detach the reservoir mounting bracket.

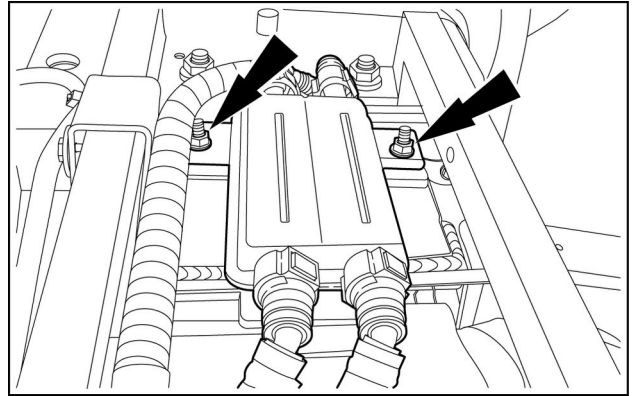

BAIL15TR00965AA 30

31. • Disconnect the coolant expansion tank hoses (1).
• Disconnect the air filter outlet pipe (2).

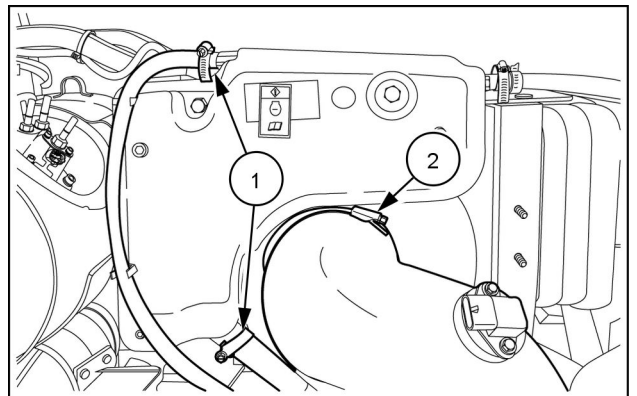

BAIL15TR00966AA 31

32. Detach the NO_x module.

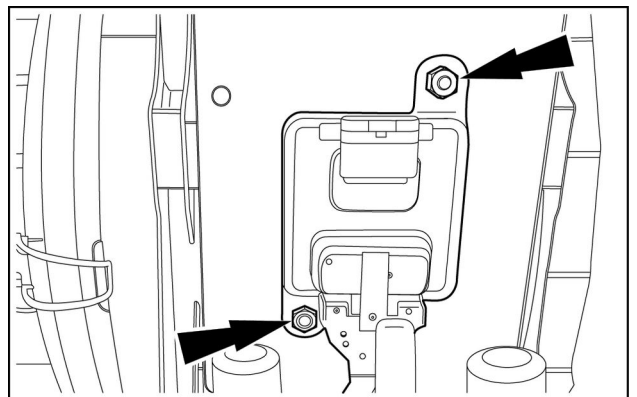

BAIL15TR00969AA 32

33. Remove the air filter frame retaining nuts.

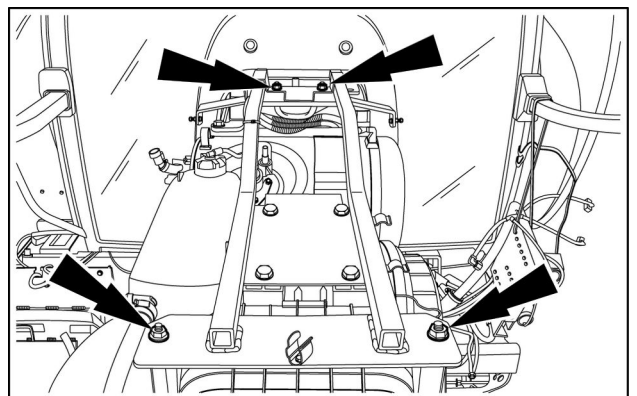

BAIL15TR00967AA 33

34. Using suitable lifting equipment, remove the air filter and frame.

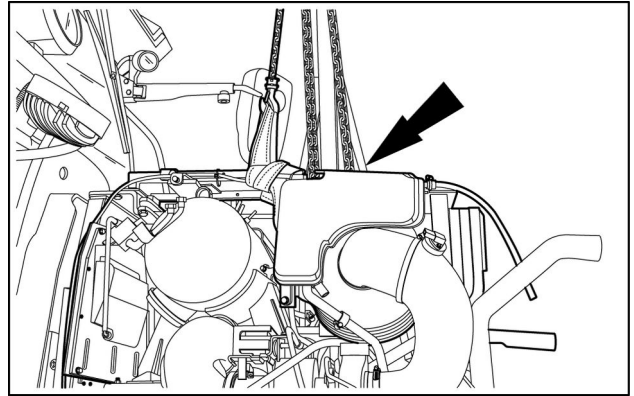

BAIL15TR00968AA 34

35. • Disconnect the air compressor banjo connector (1).
• Disconnect the air compressor coolant hose (2).

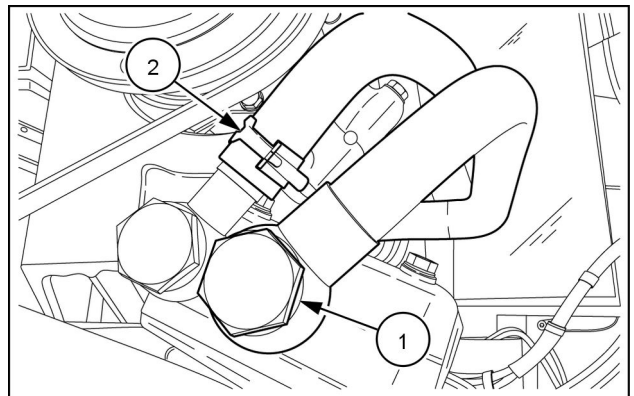

BAIL15TR00970AA 35

36. Disconnect the engine breather outlet hose.

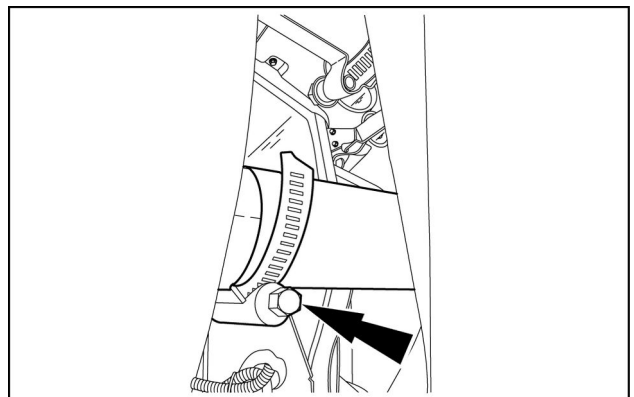

BAIL15TR00972AA 36

37. Remove the air intake pipe.

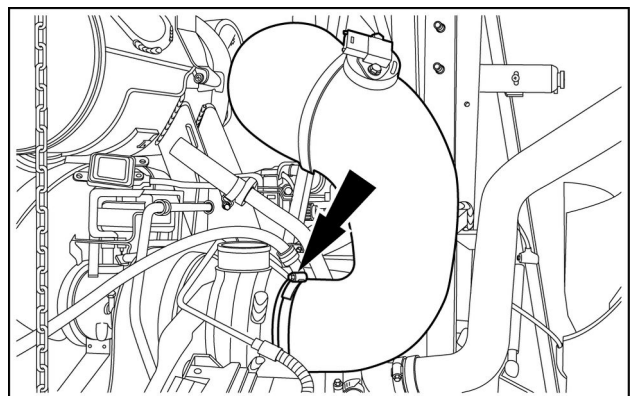

BAIL15TR00971AA 37



Suggest:

If the above button click is invalid.

Please download this document

first, and then click the above link

to download the complete manual.

Thank you so much for reading

38. Disconnect the turbo outlet pipe.

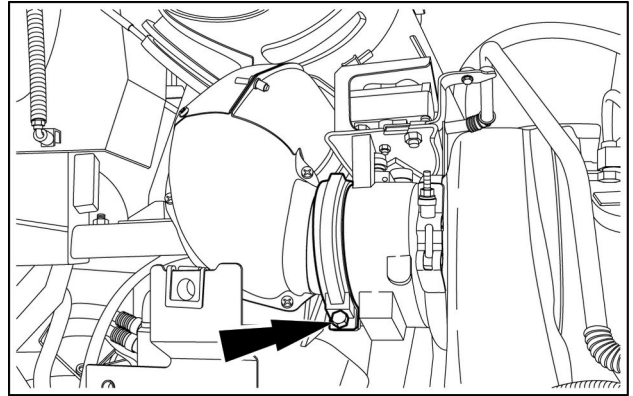

BAIL15TR00973AA 38

39. Remove the engine upper frame rear retaining nuts.

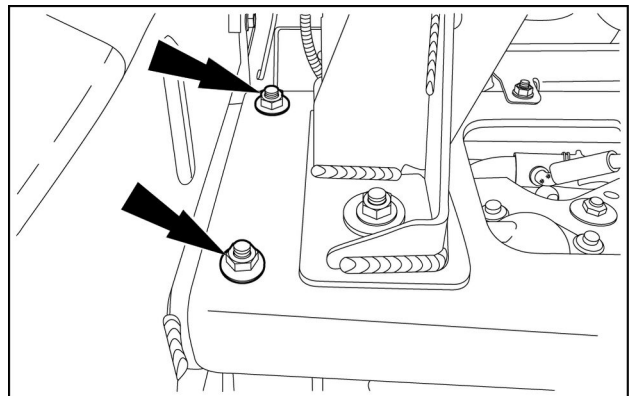

BAIL15TR00974AA 39

40. Remove the engine upper frame front retaining nuts.

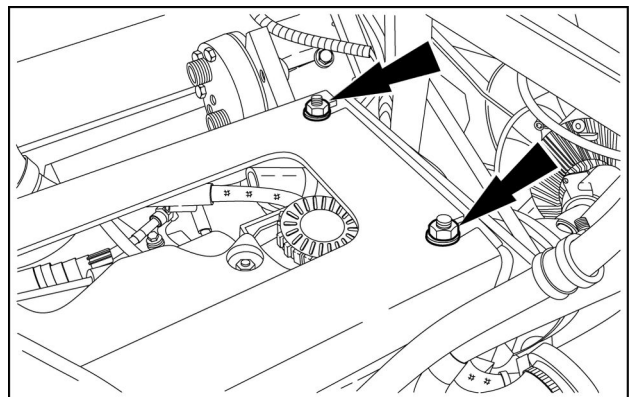

BAIL15TR00975AA 40

41. **⚠ WARNING**

Avoid injury!
The component is heavy. Removal/installation requires two persons or a lifting device.
Failure to comply could result in death or serious injury.

W1141A

Using suitable lifting equipment, remove the engine upper frame and DOC.

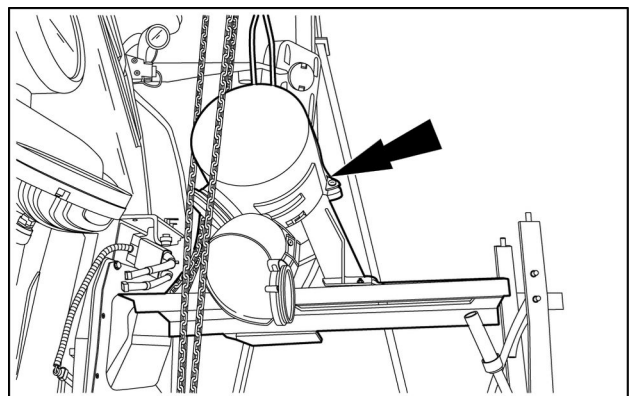

BAIL15TR00976AA 41

<https://www.ebooklibonline.com>

Hello dear friend!

Thank you very much for reading.

Enter the link into your browser.

The full manual is available for immediate download.

<https://www.ebooklibonline.com>