

Magnum™ 250

Magnum™ 280

Magnum™ 310

Magnum™ 340

Magnum™ 380

Magnum™ 310 Rowtrac™

Magnum™ 340 Rowtrac™

Magnum™ 380 Rowtrac™

**Continuously Variable Transmission (CVT)
Tractor**

PIN ZJRF04001 and above

SERVICE MANUAL

Part number 51537926

1st edition English

March 2019

© 2019 CNH Industrial America LLC. All Rights Reserved.

CASE IH
AGRICULTURE

Link Product / Engine

Product	Market Product	Engine
Magnum™ 250 CVT TIER 2 [ZJRF04001 -]	Australia New Zealand	F2CFA613G*E024
Magnum™ 250 CVT TIER 2 [ZJRF04001 -]	Asia Pacific	F2CFA613G*E024
Magnum™ 280 CVT TIER 2 [ZJRF04001 -]	Asia Pacific	F2CFA613G*E024
Magnum™ 280 CVT TIER 2 [ZJRF04001 -]	Latin America	F2CFA613G*E024
Magnum™ 280 CVT TIER 2 [ZJRF04001 -]	Australia New Zealand	F2CFA613G*E024
Magnum™ 310 CVT TIER 2 [ZJRF04001 -]	Asia Pacific	F2CFA613G*E024
Magnum™ 310 CVT TIER 2 [ZJRF04001 -]	Australia New Zealand	F2CFA613G*E024
Magnum™ 310 CVT TIER 2 [ZJRF04001 -]	Latin America	F2CFA613G*E024
Magnum™ 340 CVT TIER 2 [ZJRF04001 -]	Asia Pacific	F2CFA614D*E021
Magnum™ 340 CVT TIER 2 [ZJRF04001 -]	Australia New Zealand	F2CFA614D*E021
Magnum™ 340 CVT TIER 2 [ZJRF04001 -]	Latin America	F2CFA614D*E021
Magnum™ 380 CVT TIER 2 [ZJRF04001 -]	Asia Pacific	F2CFA614D*E021
Magnum™ 380 CVT TIER 2 [ZJRF04001 -]	Latin America	F2CFA614D*E021
Magnum™ 380 CVT TIER 2 [ZJRF04001 -]	Australia New Zealand	F2CFA614D*E021
Magnum™ 310 Rowtrac™ CVT TIER 2 [ZJRF04001 -]	Australia New Zealand	F2CFA613B*E023
Magnum™ 310 Rowtrac™ CVT TIER 2 [ZJRF04001 -]	Asia Pacific	F2CFA613B*E023
Magnum™ 310 Rowtrac™ CVT TIER 2 [ZJRF04001 -]	Latin America	F2CFA613B*E023
Magnum™ 340 Rowtrac™ CVT TIER 2 [ZJRF04001 -]	Asia Pacific	F2CFA614D*E021
Magnum™ 340 Rowtrac™ CVT TIER 2 [ZJRF04001 -]	Australia New Zealand	F2CFA614D*E021
Magnum™ 340 Rowtrac™ CVT TIER 2 [ZJRF04001 -]	Latin America	F2CFA614D*E021
Magnum™ 380 Rowtrac™ CVT TIER 2 [ZJRF04001 -]	Asia Pacific	F2CFA614D*E021
Magnum™ 380 Rowtrac™ CVT TIER 2 [ZJRF04001 -]	Latin America	F2CFA614D*E021
Magnum™ 380 Rowtrac™ CVT TIER 2 [ZJRF04001 -]	Australia New Zealand	F2CFA614D*E021

Contents

INTRODUCTION

Engine	10
[10.001] Engine and crankcase	10.1
[10.101] Cylinder heads	10.2
[10.202] Air cleaners and lines	10.3
[10.206] Fuel filters	10.4
[10.216] Fuel tanks	10.5
[10.254] Intake and exhaust manifolds and muffler	10.6
[10.304] Engine lubrication system.....	10.7
[10.310] Aftercooler.....	10.8
[10.400] Engine cooling system	10.9
[10.414] Fan and drive	10.10
Transmission	21
[21.504] Continuously Variable Transmission (CVT)	21.1
[21.505] Continuously Variable Transmission (CVT) external controls.....	21.2
[21.506] Continuously Variable Transmission (CVT) hydraulic components	21.3
[21.507] Continuously Variable Transmission (CVT) internal components.....	21.4
[21.900] Hydraulic pump drive.....	21.5
Four-Wheel Drive (4WD) system	23
[23.202] Electro-hydraulic control	23.1
[23.314] Drive shaft.....	23.2
Front axle system	25
[25.100] Powered front axle	25.1
[25.102] Front bevel gear set and differential	25.2
[25.108] Final drive hub, steering knuckles, and shafts	25.3
[25.122] Axle suspension control.....	25.4

<https://www.ebooklibonline.com>

Hello dear friend!

Thank you very much for reading.

Enter the link into your browser.

The full manual is available for immediate download.

<https://www.ebooklibonline.com>

Rear axle system	27
[27.100] Powered rear axle.....	27.1
[27.106] Rear bevel gear set and differential.....	27.2
[27.120] Planetary and final drives	27.3
[27.610] Rear axle track yoke assembly	27.4
Power Take-Off (PTO)	31
[31.104] Rear electro-hydraulic control.....	31.1
[31.110] One-speed rear Power Take-Off (PTO)	31.2
[31.114] Two-speed rear Power Take-Off (PTO)	31.3
[31.146] Front Power Take-Off (PTO)	31.4
Brakes and controls	33
[33.110] Parking brake or parking lock	33.1
[33.202] Hydraulic service brakes	33.2
[33.220] Trailer brake hydraulic control.....	33.3
[33.224] Trailer brake pneumatic control	33.4
Hydraulic systems	35
[35.000] Hydraulic systems.....	35.1
[35.102] Pump control valves.....	35.2
[35.106] Variable displacement pump	35.3
[35.114] Three-point hitch control valve	35.4
[35.124] Three-point hitch hydraulic adjustment	35.5
[35.204] Remote control valves	35.6
[35.300] Reservoir, cooler, and filters.....	35.7
[35.304] Combination pump units	35.8
Hitches, drawbars, and implement couplings	37
[37.110] Rear three-point hitch	37.1
[37.120] Rear three-point hitch linkage.....	37.2
[37.162] Front hitch	37.3

Frames and ballasting	39
[39.100] Frame	39.1
Steering.....	41
[41.101] Steering control	41.1
[41.200] Hydraulic control components.....	41.2
[41.206] Pump	41.3
[41.432] Autoguidance steering	41.4
Wheels	44
[44.520] Rear wheels	44.1
Tracks and track suspension.....	48
[48.100] Tracks	48.1
[48.130] Track frame and driving wheels.....	48.2
[48.134] Track tension units	48.3
[48.138] Track rollers	48.4
Cab climate control	50
[50.100] Heating	50.1
[50.200] Air conditioning.....	50.2
[50.300] Cab pressurizing system	50.3
Electrical systems	55
[55.000] Electrical system	55.1
[55.010] Fuel injection system.....	55.2
[55.012] Engine cooling system	55.3
[55.013] Engine oil system	55.4
[55.014] Engine intake and exhaust system.....	55.5
[55.015] Engine control system.....	55.6
[55.024] Transmission control system	55.7
[55.045] Front axle control system	55.8
[55.046] Rear axle control system.....	55.9

[55.047] Steering control system	55.10
[55.050] Heating, Ventilation, and Air-Conditioning (HVAC) control system.....	55.11
[55.051] Cab Heating, Ventilation, and Air-Conditioning (HVAC) controls.....	55.12
[55.100] Harnesses and connectors.....	55.13
[55.130] Rear three-point hitch electronic control system	55.14
[55.201] Engine starting system	55.15
[55.301] Alternator	55.16
[55.302] Battery.....	55.17
[55.408] Warning indicators, alarms, and instruments	55.18
[55.510] Cab or platform harnesses and connectors.....	55.19
[55.512] Cab controls.....	55.20
[55.513] Cab transmission controls.....	55.21
[55.518] Wiper and washer system.....	55.22
[55.640] Electronic modules	55.23
[55.DTC] FAULT CODES.....	55.24
Platform, cab, bodywork, and decals	90
[90.100] Engine hood and panels	90.1
[90.102] Engine shields, hood latches, and trims	90.2
[90.124] Pneumatically-adjusted operator seat.....	90.3
[90.150] Cab.....	90.4
[90.151] Cab interior.....	90.5
[90.160] Cab interior trim and panels.....	90.6



INTRODUCTION

Foreword - Important notice regarding equipment servicing

All repair and maintenance work listed in this manual must be carried out only by qualified dealership personnel, strictly complying with the instructions given, and using, whenever possible, the special tools.

Anyone who performs repair and maintenance operations without complying with the procedures provided herein shall be responsible for any subsequent damages.

The manufacturer and all the organizations of its distribution chain, including - without limitation - national, regional, or local dealers, reject any responsibility for damages caused by parts and/or components not approved by the manufacturer, including those used for the servicing or repair of the product manufactured or marketed by the manufacturer. In any case, no warranty is given or attributed on the product manufactured or marketed by the manufacturer in case of damages caused by parts and/or components not approved by the manufacturer.

The manufacturer reserves the right to make improvements in design and changes in specifications at any time without notice and without incurring any obligation to install them on units previously sold. Specifications, descriptions, and illustrative material herein are as accurate as known at time of publication but are subject to change without notice.

In case of questions, refer to your CASE IH Sales and Service Networks.

Safety rules

Personal safety



This is the safety alert symbol. It is used to alert you to potential personal injury hazards. Obey all safety messages that follow this symbol to avoid possible death or injury.

Throughout this manual you will find the signal words DANGER, WARNING, and CAUTION followed by special instructions. These precautions are intended for the personal safety of you and those working with you.

Read and understand all the safety messages in this manual before you operate or service the machine.

 DANGER indicates a hazardous situation that, if not avoided, will result in death or serious injury.

 WARNING indicates a hazardous situation that, if not avoided, could result in death or serious injury.

 CAUTION indicates a hazardous situation that, if not avoided, could result in minor or moderate injury.

FAILURE TO FOLLOW DANGER, WARNING, AND CAUTION MESSAGES COULD RESULT IN DEATH OR SERIOUS INJURY.

Machine safety

NOTICE: Notice indicates a situation that, if not avoided, could result in machine or property damage.

Throughout this manual you will find the signal word Notice followed by special instructions to prevent machine or property damage. The word Notice is used to address practices not related to personal safety.

Information

NOTE: Note indicates additional information that clarifies steps, procedures, or other information in this manual.

Throughout this manual you will find the word Note followed by additional information about a step, procedure, or other information in the manual. The word Note is not intended to address personal safety or property damage.

Safety rules - General maintenance safety

General maintenance safety

Keep the area used for servicing the machine clean and dry. Clean up spilled fluids.

Service the machine on a firm, level surface.

Install guards and shields after you service the machine.

Close all access doors and install all panels after servicing the machine.

Do not attempt to clean, lubricate, clear obstructions, or make adjustments to the machine while it is in motion or while the engine is running.

Always make sure that working area is clear of tools, parts, other persons and pets before you start operating the machine.

Unsupported hydraulic cylinders can lose pressure and drop the equipment, causing a crushing hazard. Do not leave equipment in a raised position while parked or during service, unless the equipment is securely supported.

Jack or lift the machine only at jack or lift points indicated in this manual.

Incorrect towing procedures can cause accidents. When you tow a disabled machine follow the procedure in this manual. Use only rigid tow bars.

Stop the engine, remove the key, and relieve pressure before you connect or disconnect fluid lines.

Stop the engine and remove the key before you connect or disconnect electrical connections.

Scalding can result from incorrect removal of coolant caps. Cooling systems operate under pressure. Hot coolant can spray out if you remove a cap while the system is hot. Allow the system to cool before you remove the cap. When you remove the cap, turn it slowly to allow pressure to escape before you completely remove the cap.

Replace damaged or worn tubes, hoses, electrical wiring, etc.

The engine, transmission, exhaust components, and hydraulic lines may become hot during operation. Take care when you service such components. Allow surfaces to cool before you handle or disconnect hot components. Wear protective equipment when appropriate.

When welding, follow the instructions in the manual. Always disconnect the battery before you weld on the machine. Always wash your hands after you handle battery components.



SERVICE MANUAL

Engine

Magnum™ 250 CVT TIER 2 [ZJRF04001 -], Magnum™ 280 CVT TIER 2 [ZJRF04001 -], Magnum™ 310 CVT TIER 2 [ZJRF04001 -], Magnum™ 310 Rowtrac™ CVT TIER 2 [ZJRF04001 -], Magnum™ 340 CVT TIER 2 [ZJRF04001 -], Magnum™ 340 Rowtrac™ CVT TIER 2 [ZJRF04001 -], Magnum™ 380 CVT TIER 2 [ZJRF04001 -], Magnum™ 380 Rowtrac™ CVT TIER 2 [ZJRF04001 -]

Visual external differences for Magnum™ tractor engines

There are a few things that make the FPT **Cursor® 9** engine used in the **Magnum™** tractors visually and mechanically different from other **Cursor® 9** applications.

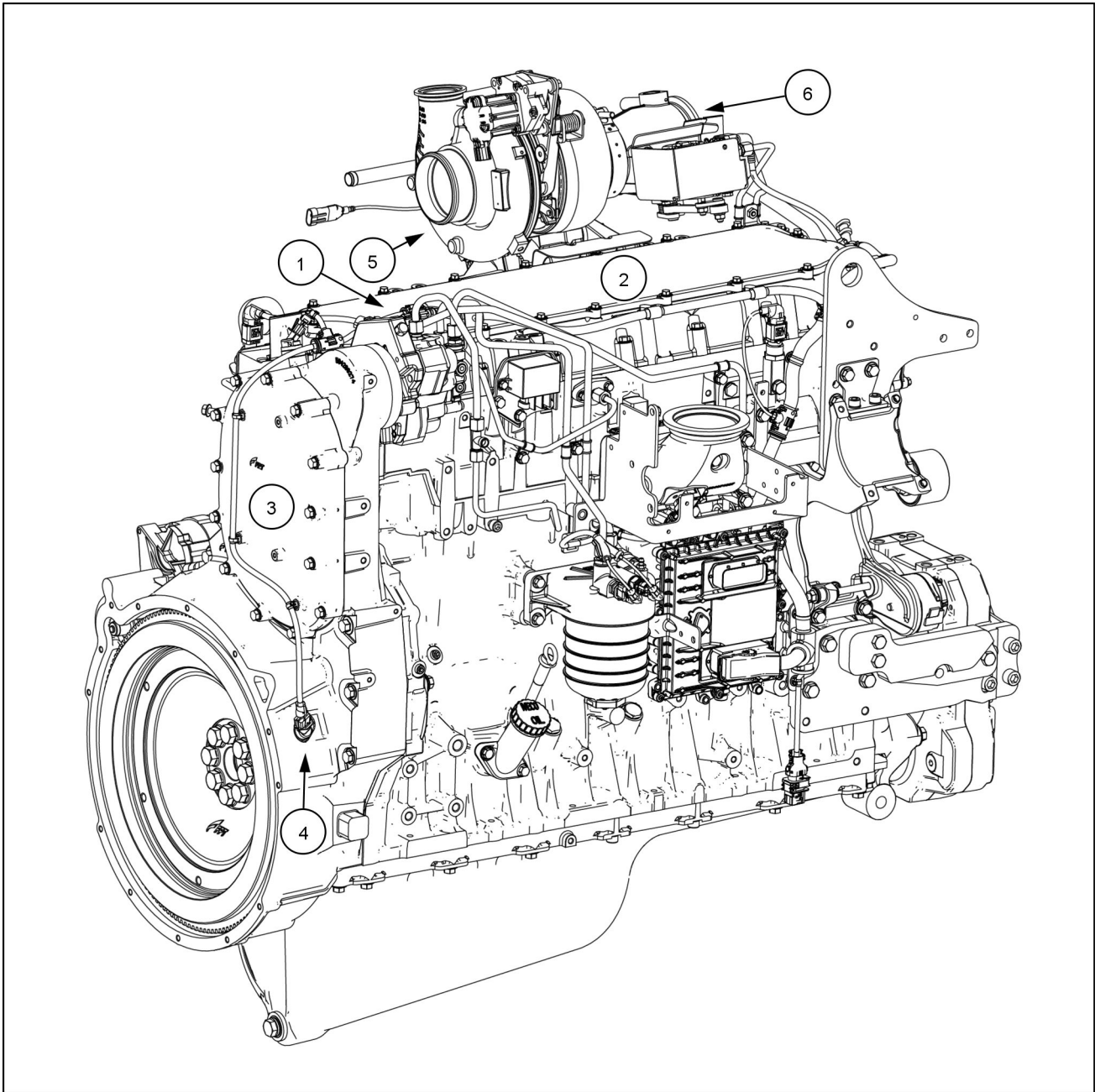

RAIL15TR00608GA 3

1. The fuel pump sits higher and closer to the center line of the engine.
2. A two piece valve cover assembly that allows for valve adjustment without removing the entire cover.
3. The rear cover is an oval shape where on other **Cursor® 9** engines it's round.
4. The flywheel speed sensor is located on the right side of the engine, others have on the left side of the engine.
5. The turbocharger is moved higher and toward the center line of the engine.
6. Exhaust flap for TIER 4B.

Exhaust brake

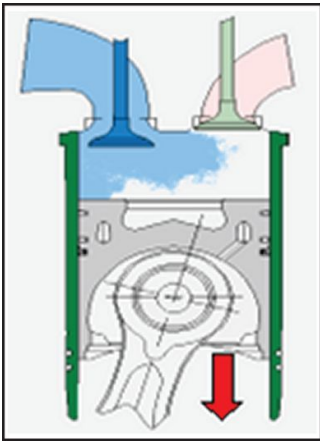

Admission phase:
Intake of fresh air.

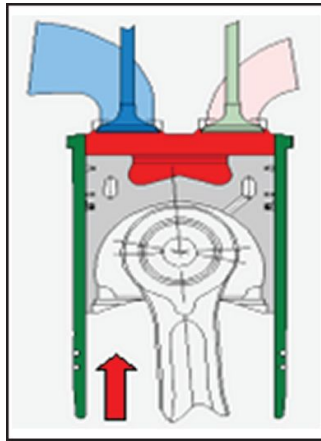

Compression phase:
Energy is stored in the compressed air, braking effect increases with compression

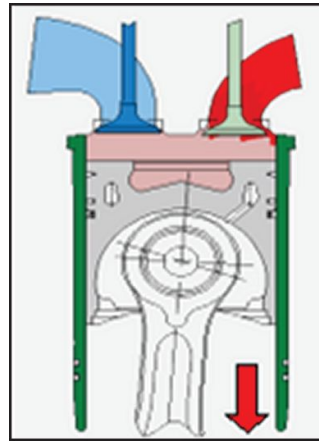

Top dead center:
Exhaust valves open, compressed air is released, energy is blown out.

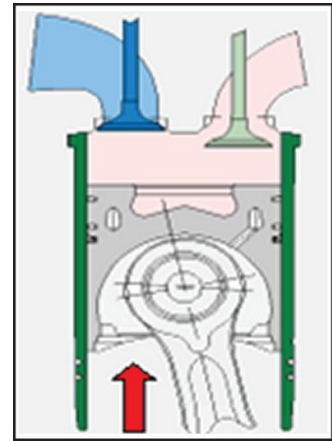

Exhaust phase:
Cylinder is empty, no energy exchange. Exhaust gases impact against the turbine, creating an additional braking effect.

All **Cursor®** engines are equipped with an advanced engine brake system: the Iveco Turbo Brake (IBT) system.

- Decompression engine brake
- Quick responding
- Integrated in the engine control
- Linked to cruise control
- Linked to EBS

Advantage

- Less brake pad wear
- Automatically engaged

Benefit

- Reduced operation cost
- Operator ease

The engine brake is controlled by the Tractor Control Unit (TCU). The Electronic Service Tool (EST) is used to configure the TCU as to whether or not the tractor has an engine brake.

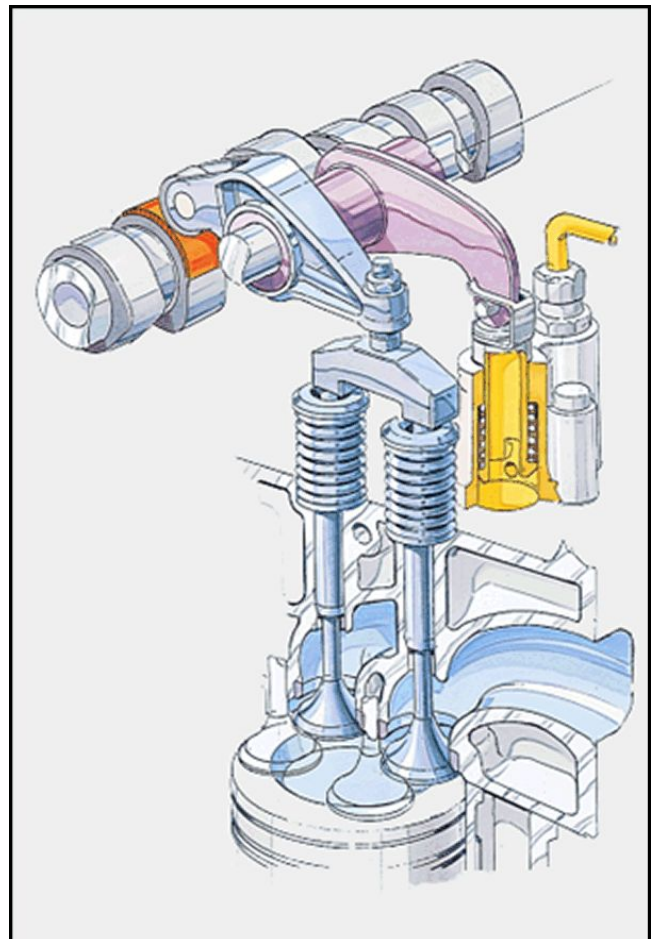

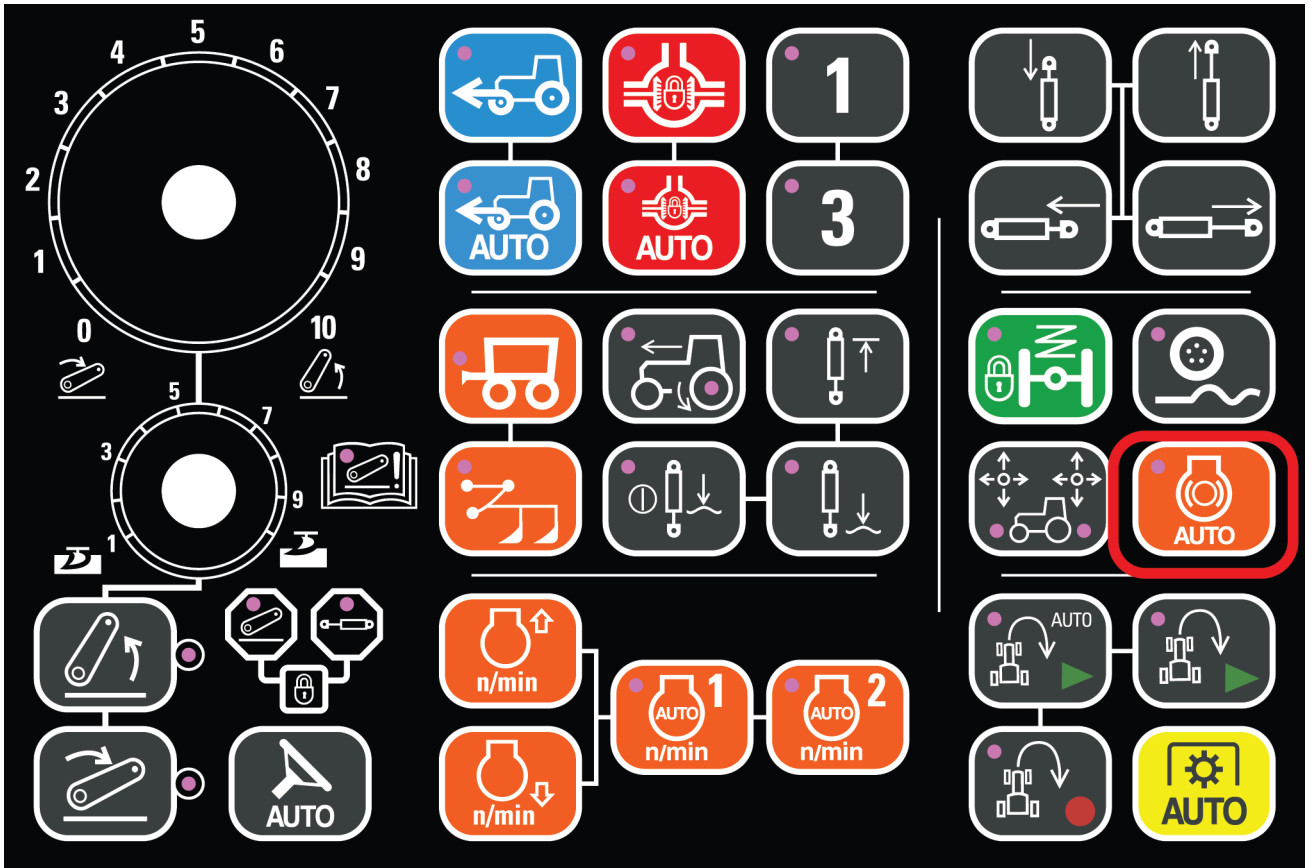

RAIL15TR00415GA 4

The engine brake switch on the Integrated Control Panel (ICP) activates the system. When the switch is activated, and the difference between the commanded (throttle) and actual engine speed exceeds a **30%** threshold, the software activates the brake.

Air Induction - cross flow cylinder head

The cylinder head is of the cross flow design, inlet on one side and exhaust on the other. This and four valves per cylinder give it excellent breathing ability and efficient temperature control. The air is supplied to the inlet by a wastegate turbocharger or a Variable Geometry Turbocharger (VGT).

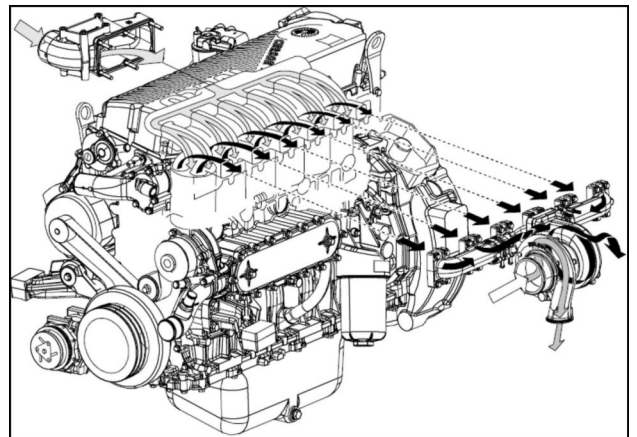

RAIL15TR00376BA 5

Wastegate turbocharger

The wastegate turbocharger allows for a larger turbocharger to be installed producing higher boost pressures in the low and midrange rpm while not over-boosting at high rpm.

Intake pressure builds against a diaphragm in the wastegate and opens a valve allowing exhaust to bypass the turbine therefore slowing the compressor and limiting the pressure in the intake manifold.

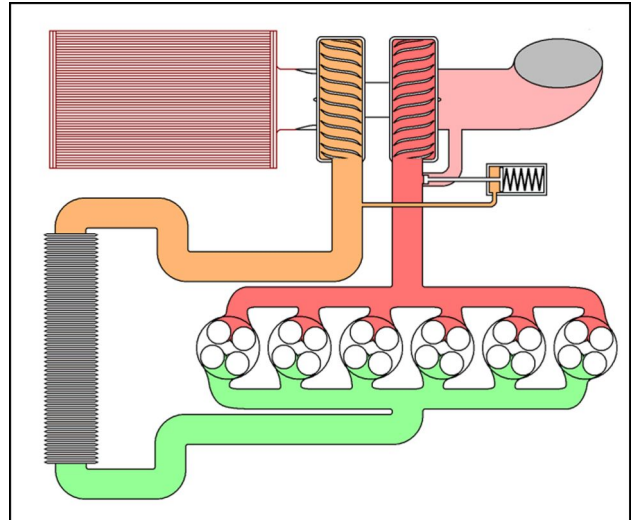

RAIL15TR00396BA 6

Electronically Variable Geometry Turbocharger (eVGT)

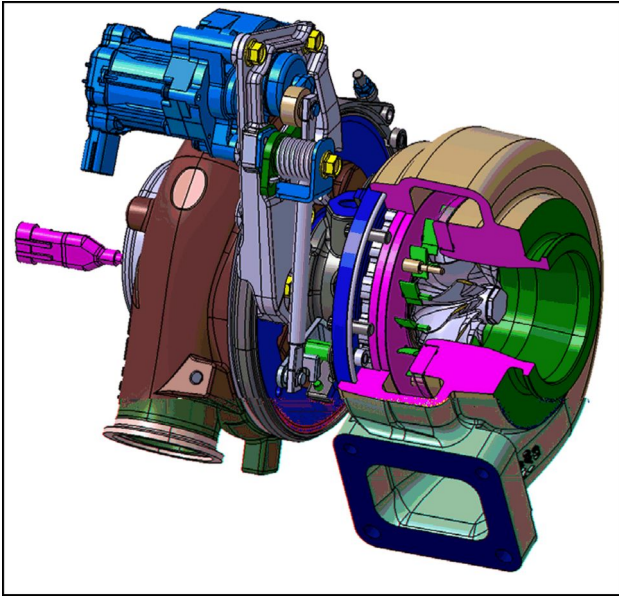

RAIL15TR00383BA 7

The electronically Variable Geometry Turbocharger (eVGT) is used on the TIER 4A **Magnum™** 370 and TIER 4B **Magnum™** 280, 310, 340 and 380. . The eVGT is electronically controlled by the Engine Control Unit (ECU).

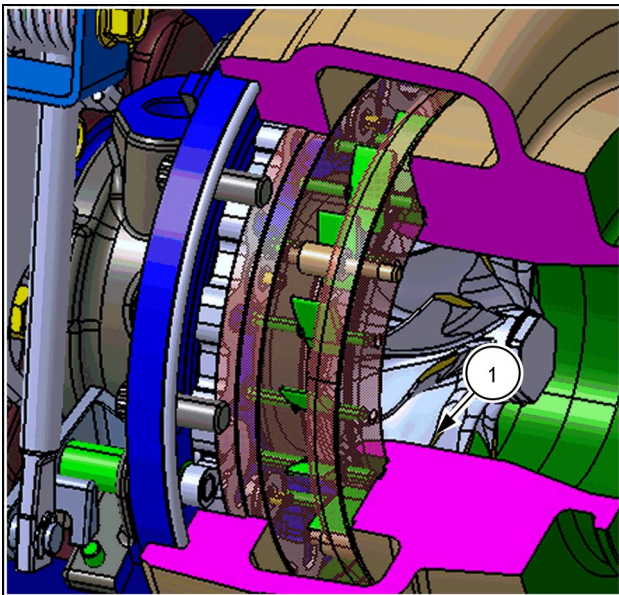

RAIL15TR00395BA 8

Vanes open (low boost)

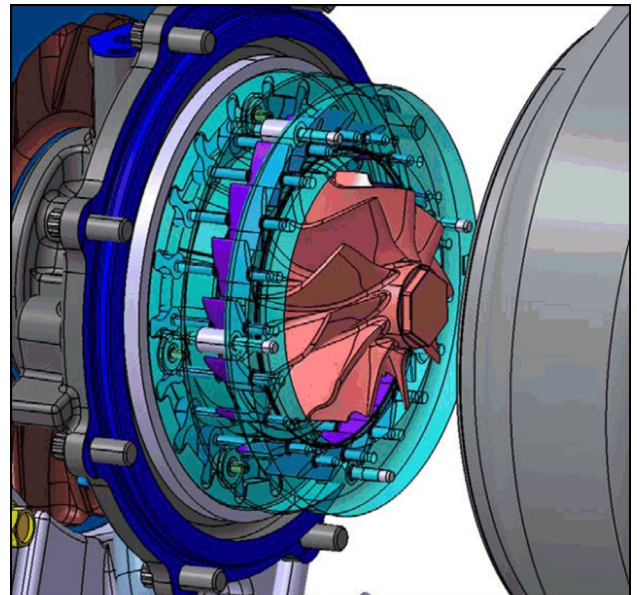

RAIL15TR00394BA 9

Vanes closed (high boost)

The eVGT uses a series of aerodynamic vanes to direct exhaust toward the turbine controlling both the velocity and angle the exhaust contacts the turbine. This gives the ECU the ability to dynamically “tune” the boost pressure at any given engine speed and load, Improving performance and fuel economy.

Fully open the velocity slows and the angle is decreased therefore the turbine and compressor turn slower producing less boost. When needed, the vanes close increasing the velocity and angle, therefore increasing turbine and compressor speed, producing higher boost anytime it is needed across the entire operating range of the engine.

EDC17CV41

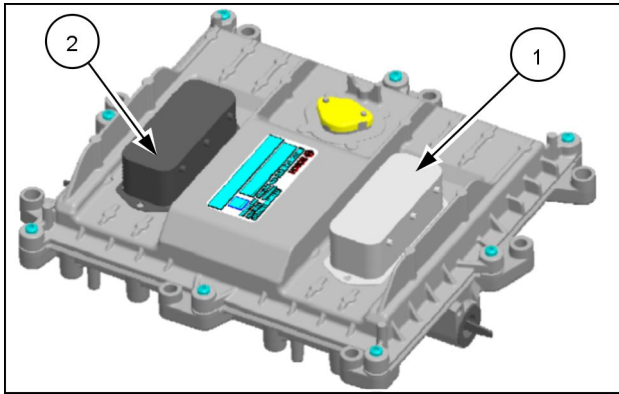

RAIL14TR00234PA 10

A new Engine Control Unit (ECU) is used on TIER 4B engines, the EDC17CV41. It is used on FPT engines from the **4.5 L** NEF to the **12.9 L Cursor®** engines. It has two 96-pin electrical connectors: one for the engine components and one for the tractor connections. Pin connections will be common for all the CNH/FPT engines using this controller.

1. Tractor connector
2. Engine connector

The EDC17CV41 controls all engine and Selective Catalytic Reduction (SCR) functions.

Lubrication System

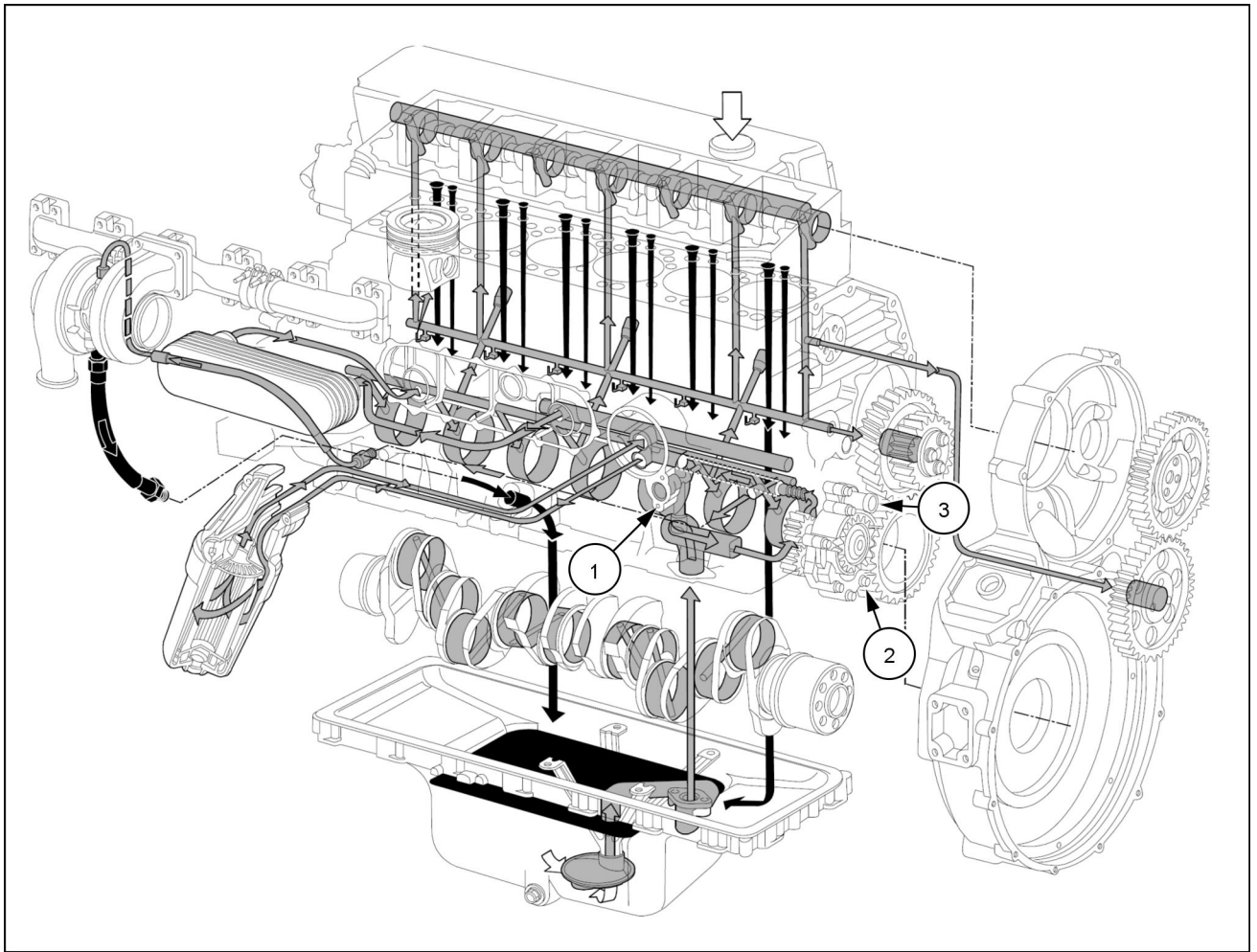

RAIL15TR00416GA 11

Oil pressure is controlled by a **5 bar (72.5 psi)** relief valve (1) in the oil galley coming from the gear type oil pump (2) located behind the rear cover of the engine. The oil pump also has an over pressurization relief valve (3) set at approximately **10 bar (145 psi)**.

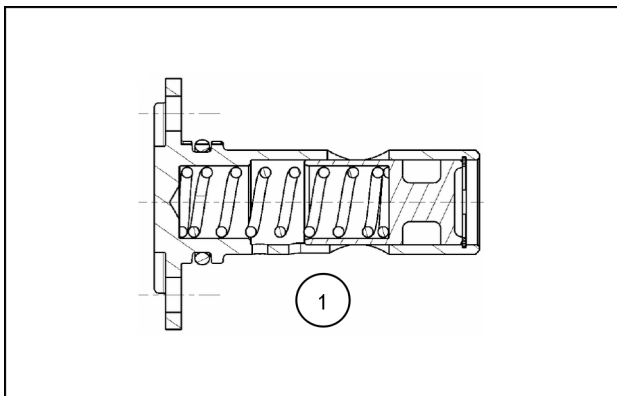

RAIL15TR00367AA 12

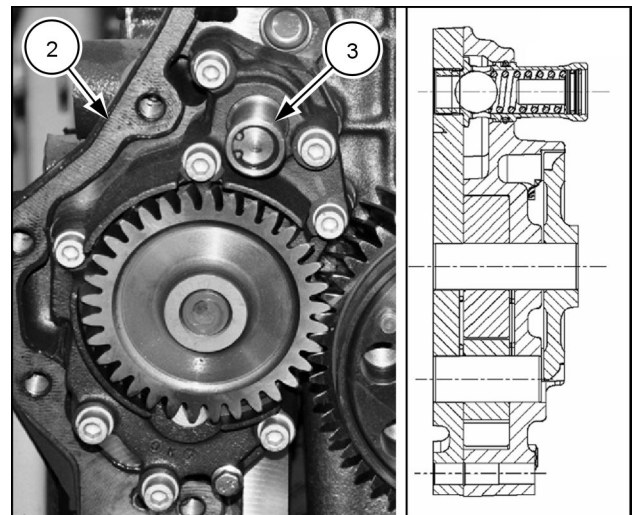

RAIL15TR00389BA 13

A **5 bar (72.5 psi)** oil pressure control valve (1) is located on the left hand side of the engine. The oil pump assembly (2) includes an over pressurization relief valve (3) that protects the pump. The valve opens at **9.4 – 10.8 bar (136.3 – 156.6 psi)**.

Blow-by recirculation

Blow-by is controlled by a rotary filter bolted to the rear of the camshaft. As the cam turns excess oil is thrown off by centrifugal force, finer oil is filtered out.

The blow-by then passes through the center of the camshaft and exits at the front.

This filter must be replaced at regular intervals or the engine will build up excessive pressure in the crank case.

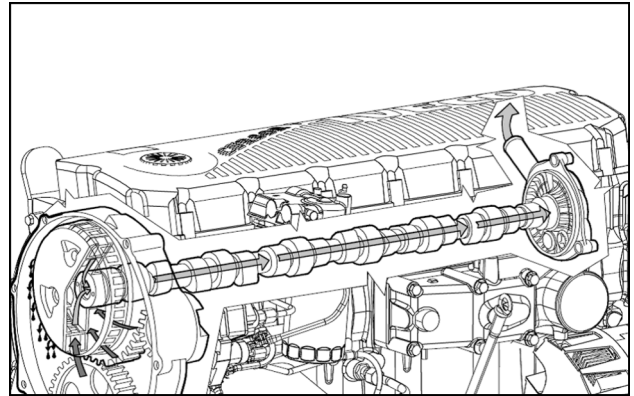

RAIL15TR00366AA 14

Built into the cover at the front is a valve that allows blow-by pressures out, but will not allow atmospheric pressure into the crankcase.

This filtered air is directed back into the inlet and re-burned.

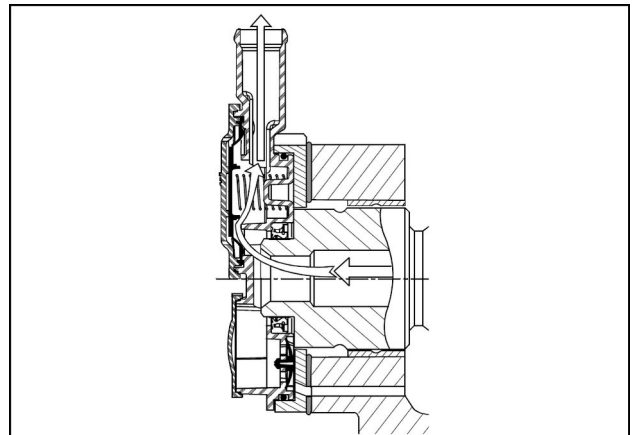

RAIL15TR00377BA 15

Connecting Rods

Connecting rods must all be the same weight class in an engine. The weight class is identified by a color swatch on the connecting rod.

There are three classes of crankshaft bearing diameters (bore size) on the connecting rod. The bore size is marked by a color code on the rod. The oil clearance is determined by the connecting rod bore size and the crankshaft journal size. Based on connecting rod bore diameter and the crankshaft journal diameter a bearing set must be determined.

Connecting rods are the fracture split type. Care must be taken when handling these rods as any damage to the cap/rod mating area requires that the rod be replaced.

Connecting rod weight, class and color	Bore diameter and color designation	
3450 – 3470 grams Grade A, Yellow	85.987 - 58.996	Yellow
	85.997 - 86.005	Green
	86.006 - 86.013	Blue
3471 – 3490 grams Grade B, Green	85.987 - 58.996	Yellow
	85.997 - 86.005	Green
	86.006 - 86.013	Blue
3491 – 3510 grams Grade C, Blue	85.987 - 58.996	Yellow
	85.997 - 86.005	Green
	86.006 - 86.013	Blue

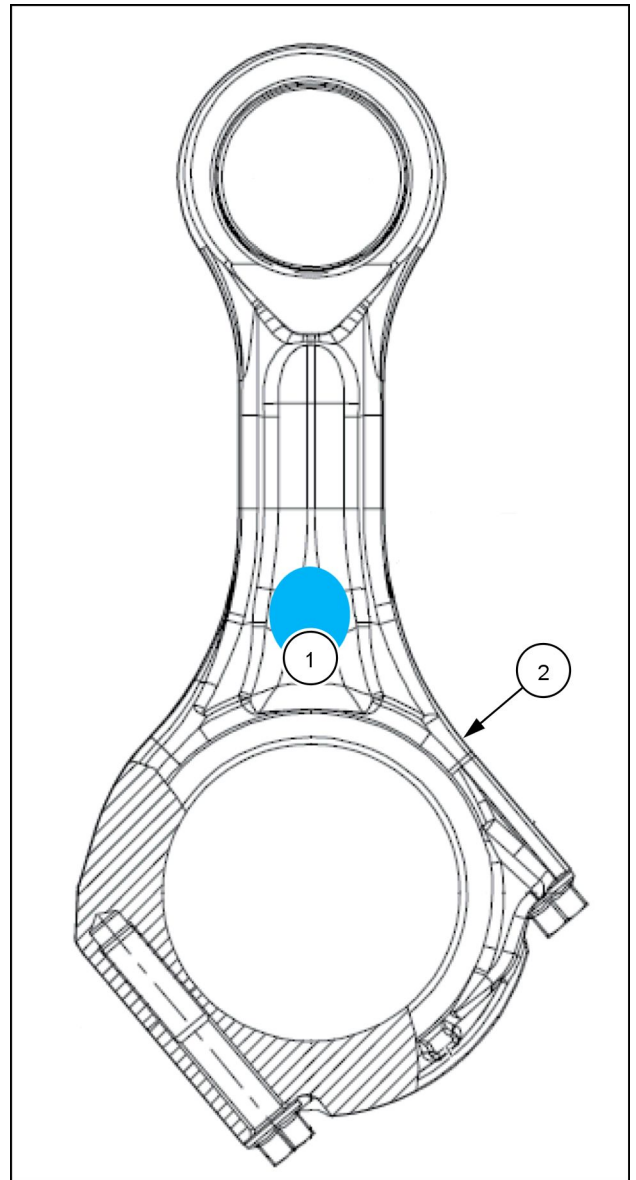

RAIL15TR00397CA 16

Fracture split rods give nearly perfect alignment. In both examples the red (rod) profiles are identical as are the blue (cap) profiles. In the top example the rod fits perfectly with the cap. In the lower example the rod is in the same position but the cap is reversed, here the material peaks align peak to peak and keeps cap from mating with the rod.

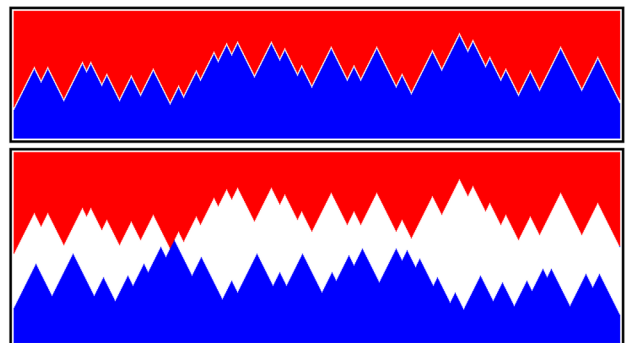

RAIL15TR00375AA 17

Crankshaft

- The crankshaft are classified in three classes: there are three classes for the connecting rod journals and three classes for the main journals.
- The crankshaft journal sizes are stamped on the rear flyweight for both the connecting rod journals and the main journals.
- Six digits for the connecting rods and seven digits for the mains.
- The crankshaft may have been ground - **0.127 mm** undersize from the factory. A (1) preceding the six digits is a standard crankshaft, a (2) preceding is for a crankshaft that has been ground undersize.
- The main bearing bores in the block are classed 1,2, or 3 and are located on the rear of the block lower right hand side. If the classifications are not found, the crankshaft must be measured and classified for each journal.

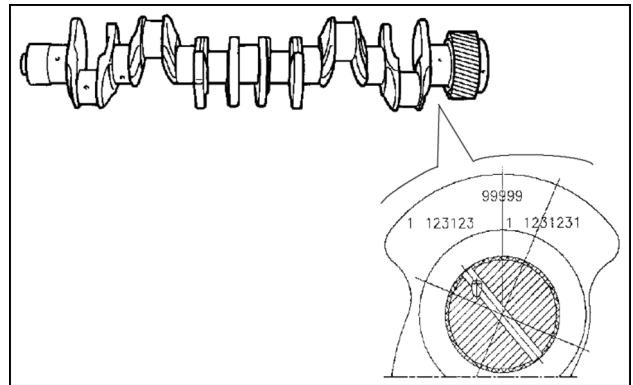

CRANKIDENTIFY 18

Standard crankshaft connecting rod bearing selection

Standard crankshaft connecting rod journals	Connecting rod bore		
	Class (1) Yellow paint	Class (2) Green paint	Class (3) Blue paint
Class (1) 81.915 to 81.925 mm	Green	Green	Yellow
	Green	Yellow	Yellow
Class (2) 81.925 to 81.935 mm	Red	Green	Green
	Green	Green	Yellow
Class (3) 81.935 to 81.945 mm	Red	Red	Green
	Red	Green	Green

NOTE: It may be necessary to mix two bearing shells in one journal.

0.127 mm under-size crankshaft connecting rod bearing selection

- 0.127 mm Standard crankshaft connecting rod journals	Connecting rod bore		
	Class (1) Yellow paint	Class (2) Green paint	Class (3) Blue paint
Class (1) 81.789 to 81.799 mm	Green/Black	Green/Black	Yellow/Black
	Green/Black	Yellow/Black	Yellow/Black
Class (2) 81.799 to 81.809 mm	Red/Black	Green/Black	Green/Black
	Green/Black	Green/Black	Yellow/Black
Class (3) 81.809 to 81.819 mm	Red/Black	Red/Black	Green/Black
	Red/Black	Green/Black	Green/Black

Standard crankshaft main bearing selection

Standard crankshaft journals	Main bearing bore fit class		
	Class (1)	Class (2)	Class (3)
Class (1) 92.970 to 92.980 mm	Green	Green	Yellow
	Green	Yellow	Yellow
Class (2) 92.980 to 92.990 mm	Red	Green	Green
	Green	Green	Yellow
Class (3) 92.990 to 93.000 mm	Red	Red	Green
	Red	Green	Green

0.127 mm under-size crankshaft main bearing selection

Standard crankshaft journals	Main bearing bore fit class		
	Class (1)	Class (2)	Class (3)
Class (1) 92.843 to 92.853 mm	Green/Black	Green/Black	Yellow/Black
	Green/Black	Yellow/Black	Yellow/Black
Class (2) 92.853 to 92.863 mm	Red/Black	Green/Black	Green/Black
	Green/Black	Green/Black	Yellow/Black
Class (3) 92.863 to 93.872 mm	Red/Black	Red/Black	Green/Black
	Red/Black	Green/Black	Green/Black

With the variables in the bearing selection process, it is always a good idea to use a plastic gauge to test each journal for proper clearance.

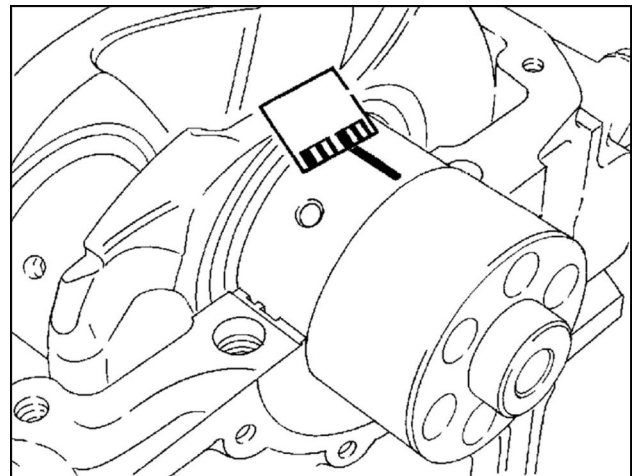

RAIL15TR00392BA 19

Camshaft installation and timing

When timing or adjusting valves it is critical to position the A, B, C or D holes in the center of the view hole **(1)** at the bottom of the bell housing. Serious engine damage can occur if procedures are not followed carefully.

- A. TDC 3 and 4
- B. TDC 1 and 6
- C. TDC 2 and 5
- D. **54°** before TDC 1 and 6

When timing or adjusting valves it is critical to position the A, B, C or D holes in the center of the view hole **(1)** at the bottom of the bell housing. Serious engine damage can occur if procedures are not followed carefully.

NOTE: All references to flywheel rotation will be made as viewed from the rear of the engine.

NOTE: The A, B and C holes are marked with one hash mark (I) and the D' hole with two hash marks (II).

Position the flywheel at TDC 1 and 6, the B hole at the bottom. This can be done by locating the D hole at the bottom view hole in the bell housing, and then turning the flywheel counterclockwise until the B hole appears.

Once the flywheel is in this position, it should be pinned in position with the flywheel pinning tool **380000150** in the sensor hole.

The engine is now ready to have the camshaft installed.

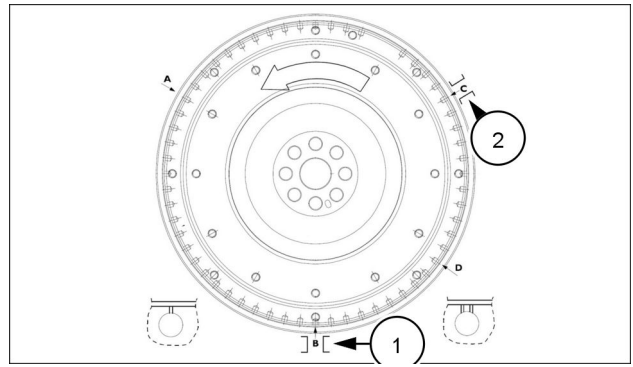

RAIL15TR00406FA 20

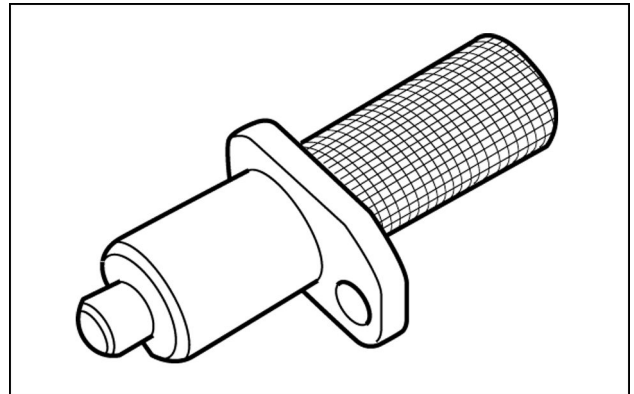

21

Install the camshaft with the three holes (viewed from the front) in the 9, 12 and 3 o'clock position.

NOTE: Do not trust the back of the cam for positioning.

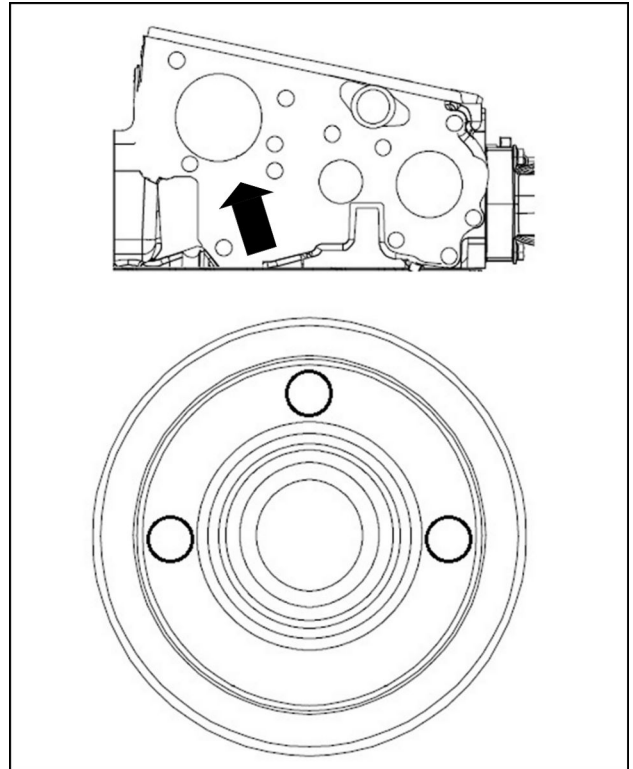

RAIL15TR00380BA 22

Install the camshaft gear as shown.

In **Magnum™** tractors, the cam drive must be installed with the three phonic wheel mounting holes making an arrow pointing to the right. If this is not done, the phonic wheel will not be able to be timed.

The slotted holes must be centered on the camshaft bolt holes to make fine adjustments to the cam later in this process.

Install the bolts and tighten, but do not torque yet; they will be loosened later in this procedure.

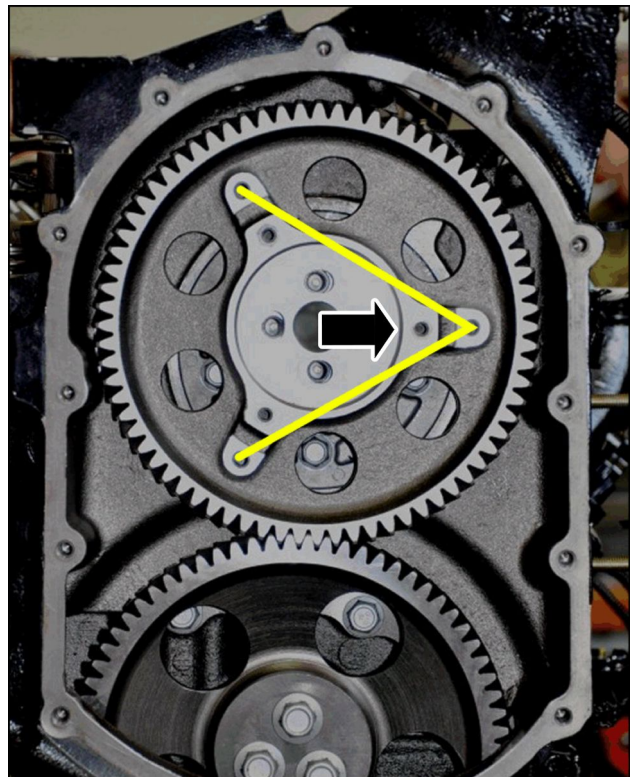

RAIL15TR00378BA 23



Suggest:

If the above button click is invalid.

Please download this document

first, and then click the above link

to download the complete manual.

Thank you so much for reading

Install the rocker arm shaft assembly using tool number: **380000149**.

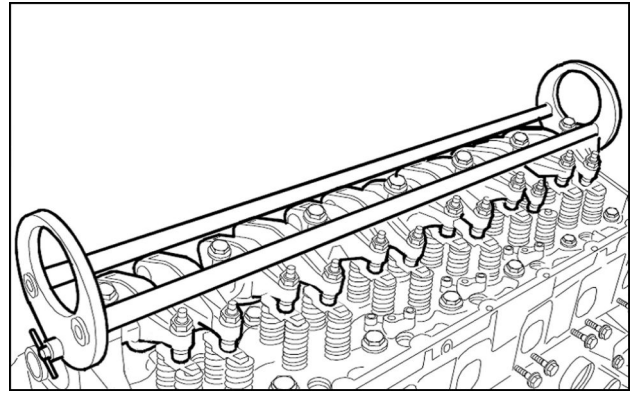

RAIL15TR00374AA 24

Camshaft timing

The double idler gear location is fixed. The upper single idler gear location can be adjusted and is used to set the back lash between the idler gear and the camshaft gear.

This back lash has to be checked and set since this is an overhead camshaft engine. All for the gear train is mounted to the block except the camshaft gear which is mounted to the cylinder head. Set the back lash before the rocker arm assembly is installed.

Use a dial indicator to measure the camshaft gear to idler back lash. Only measure the back lash between the upper idler gear and the camshaft gear. Install the dial indicator tangential to a camshaft gear tooth. Hold the idler so that it does not move and rock the camshaft gear.

Correct back lash is **0.080 – 0.180 mm (0.003 – 0.007 in)**.

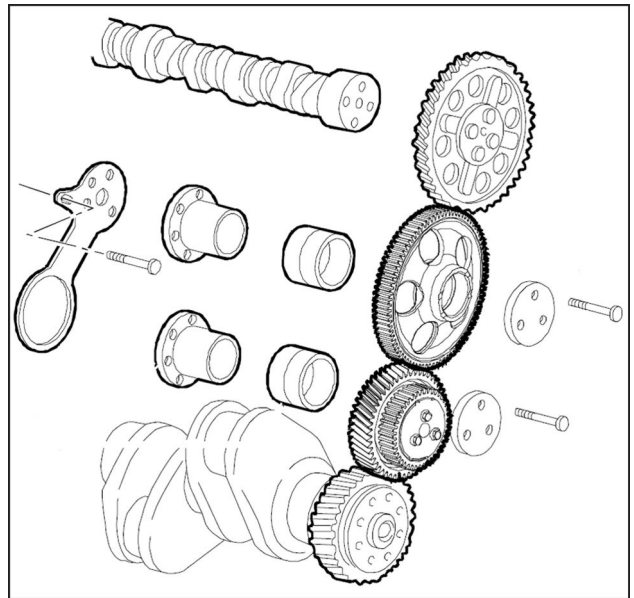

RAIL15TR01370BA 25

Rotate the flywheel clockwise until the D hole appears in the bottom view hole. Install a dial indicator **(1)** on the number 3 exhaust valve rocker arm camshaft roller **(2)** as shown.

Preload the dial indicator **6.00 mm (0.24 in)**.

Rotate the engine clockwise until the dial indicator stops moving: lift up on the valve end of the rocker arm to take any clearance or play out and to verify that you are on the inner base circle of the camshaft, the lowest point.

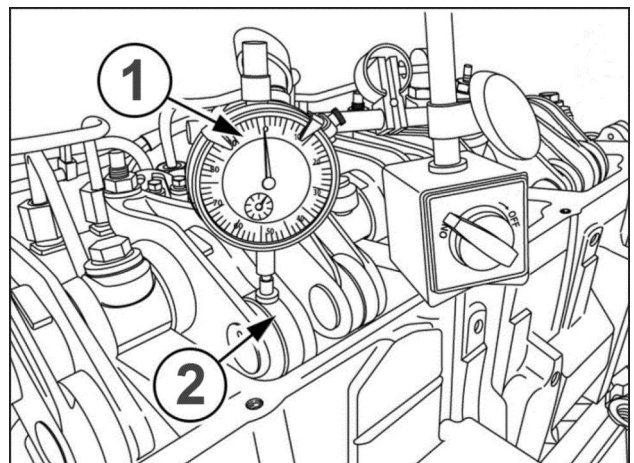

RAIL15TR01371BA 26

<https://www.ebooklibonline.com>

Hello dear friend!

Thank you very much for reading.

Enter the link into your browser.

The full manual is available for immediate download.

<https://www.ebooklibonline.com>