

AXIAL-FLOW® 7230
AXIAL-FLOW® 8230
AXIAL-FLOW® 9230

Combine

from PIN YDG218533 and above

SERVICE MANUAL

Part number 47548079

1st edition English

May 2013

CASE II
AGRICULTURE

Contents

INTRODUCTION

Engine.....	10
[10.001] Engine and crankcase	10.1
[10.202] Air cleaners and lines	10.2
[10.216] Fuel tanks	10.3
[10.210] Lift pump and lines	10.4
[10.310] Aftercooler.....	10.5
[10.400] Engine cooling system	10.6
[10.414] Fan and drive	10.7
[10.418] Rotary screen	10.8
[10.450] Engine air compressor	10.9
[10.500] Selective Catalytic Reduction (SCR) exhaust treatment.....	10.10
Main gearbox and drive	14
[14.100] Main gearbox and drive	14.1
Transmission.....	21
[21.100] Mechanical transmission lubrication system	21.1
[21.114] Mechanical transmission	21.2
[21.130] Mechanical transmission external controls.....	21.3
[21.145] Gearbox internal components.....	21.4
[21.182] Differential.....	21.5
Front axle system	25
[25.100] Powered front axle	25.1
[25.108] Final drive hub, steering knuckles, and shafts	25.2
[25.310] Final drives	25.3
Rear axle system.....	27
[27.100] Powered rear axle.....	27.1

[27.124] Final drive hub, steering knuckles, and shafts	27.2
Hydrostatic drive	29
[29.100] Transmission and steering hydrostatic control	29.1
[29.202] Hydrostatic transmission	29.2
[29.218] Pump and motor components	29.3
[29.300] Rear hydrostatic transmission	29.4
Power Take-Off (PTO)	31
[31.146] Front Power Take-Off (PTO)	31.1
Brakes and controls	33
[33.110] Parking brake or parking lock	33.1
[33.202] Hydraulic service brakes	33.2
Hydraulic systems.....	35
[35.000] Hydraulic systems	35.1
[35.102] Pump control valves.....	35.2
[35.106] Variable displacement pump	35.3
[35.220] Auxiliary hydraulic pump and lines	35.4
[35.300] Reservoir, cooler, and filters.....	35.5
[35.350] Safety and main relief valves	35.6
[35.359] Main control valve	35.7
[35.410] Header or attachment height system	35.8
[35.415] Header or attachment tilting system	35.9
[35.440] Grain tank unload system	35.10
[35.536] Crop processor system	35.11
Steering.....	41
[41.101] Steering control	41.1
[41.200] Hydraulic control components.....	41.2
[41.216] Cylinders	41.3
Wheels	44

<https://www.ebooklibonline.com>

Hello dear friend!

Thank you very much for reading.

Enter the link into your browser.

The full manual is available for immediate download.

<https://www.ebooklibonline.com>

[44.511] Front wheels.....	44.1
[44.520] Rear wheels.....	44.2
Tracks and track suspension	48
[48.100] Tracks	48.1
[48.130] Track frame and driving wheels	48.2
[48.134] Track tension units	48.3
[48.138] Track rollers	48.4
Cab climate control	50
[50.100] Heating.....	50.1
[50.104] Ventilation	50.2
[50.200] Air conditioning.....	50.3
Electrical systems.....	55
[55.000] Electrical system	55.1
[55.010] Fuel injection system.....	55.2
[55.011] Fuel tank system	55.3
[55.012] Engine cooling system	55.4
[55.013] Engine oil system	55.5
[55.014] Engine intake and exhaust system.....	55.6
[55.015] Engine control system.....	55.7
[55.023] Transmission position sensors	55.8
[55.050] Heating, Ventilation, and Air-Conditioning (HVAC) control system.....	55.9
[55.100] Harnesses and connectors.....	55.10
[55.201] Engine starting system.....	55.11
[55.202] Cold start aid	55.12
[55.301] Alternator.....	55.13
[55.302] Battery.....	55.14
[55.421] Feeding control system	55.15
[55.426] Harvest material flow control system.....	55.16
[55.640] Electronic modules.....	55.17

[55.988] Selective Catalytic Reduction (SCR) electrical system	55.18
[55.DTC] FAULT CODES.....	55.19
Attachments/Headers.....	58
[58.130] Attachment/Header frame.....	58.1
Product feeding	60
[60.105] Floating roll, feed chain, and drive	60.1
[60.110] Feeder housing.....	60.2
[60.112] Stone trapping system	60.3
[60.150] Feeder drive system	60.4
Threshing	66
[66.000] Threshing	66.1
[66.110] Concave control system.....	66.2
[66.260] Threshing mechanism drive system	66.3
[66.331] Rotor	66.4
Separation	72
[72.220] Discharge beater	72.1
[72.420] Rotary separator	72.2
Residue handling.....	73
[73.210] Straw chopper drive system.....	73.1
[73.215] Straw chopper electro-magnetic clutch support.....	73.2
[73.230] Straw chopper.....	73.3
[73.335] Chaff spreader	73.4
Cleaning	74
[74.000] Cleaning.....	74.1
[74.100] Self-leveling frame	74.2
[74.101] Cleaning drive systems	74.3
[74.110] Grain pan.....	74.4
[74.114] Upper shaker shoe	74.5

[74.118] Lower shaker shoe	74.6
[74.130] Fan housing	74.7
[74.136] Fan drive system	74.8
[74.140] Tailings return system	74.9
Crop storage / Unloading	80
[80.101] Clean grain elevator	80.1
[80.150] Grain tank	80.2
[80.175] Grain tank unload drive system	80.3
[80.180] Grain tank unload	80.4
Platform, cab, bodywork, and decals	90
[90.100] Engine hood and panels	90.1
[90.105] Machine shields and guards	90.2
[90.124] Pneumatically-adjusted operator seat	90.3
[90.150] Cab	90.4
[90.151] Cab interior	90.5



INTRODUCTION

Basic instructions - Important notice regarding equipment servicing

AXIAL-FLOW 7230 NA, AXIAL-FLOW 8230 NA, AXIAL-FLOW 9230 NA

All repair and maintenance work listed in this manual must be carried out only by qualified dealership personnel, strictly complying with the instructions given, and using, whenever possible, the special tools.

Anyone who performs repair and maintenance operations without complying with the procedures provided herein shall be responsible for any subsequent damages.

The manufacturer and all the organizations of its distribution chain, including - without limitation - national, regional, or local dealers, reject any responsibility for damages caused by parts and/or components not approved by the manufacturer, including those used for the servicing or repair of the product manufactured or marketed by the manufacturer. In any case, no warranty is given or attributed on the product manufactured or marketed by the manufacturer in case of damages caused by parts and/or components not approved by the manufacturer.

The information in this manual is up-to-date at the date of the publication. It is the policy of the manufacturer for continuous improvement. Some information could not be updated due to modifications of a technical or commercial type, or changes to the laws and regulations of different countries.

In case of questions, refer to your CASE IH AGRICULTURE Sales and Service Networks.

Personal safety

AXIAL-FLOW 7230, AXIAL-FLOW 7230 NA, AXIAL-FLOW 8230, AXIAL-FLOW 8230 NA, AXIAL-FLOW 9230, AXIAL-FLOW 9230 NA, AXIAL-FLOW 30 Series

WARNING

Risk of harm during maintenance of the machine!

Before you start servicing the machine, attach a DO NOT OPERATE warning tag to the machine in a visible area.

Failure to comply could result in death or serious injury.

W1242A

Attach a DO NOT OPERATE (TAG) to the machine in an area that is clearly visible whenever the machine is not operating properly and/or requires service.

Complete the tag information for the "REASON" the tag is attached by describing the malfunction or service required.

Validate the reason for attaching the tag by signing your name in the designated area on the tag.

The tag should only be removed by the person who signed and attached the tag, after validating the repairs or services have been completed.

Safety rules and signal word definitions

AXIAL-FLOW 7230 NA, AXIAL-FLOW 8230 NA, AXIAL-FLOW 9230 NA

Personal safety



This is the safety alert symbol. It is used to alert you to potential personal injury hazards. Obey all safety messages that follow this symbol to avoid possible death or injury.

Throughout this manual and on machine decals, you will find the signal words Danger, Warning, and Caution followed by special instructions. These precautions are intended for the personal safety of you and those working with you.

Read and understand all the safety messages in this manual before you operate or service the machine.

DANGER

DANGER indicates a hazardous situation which, if not avoided, will result in death or serious injury. The color associated with Danger is RED.

M1169A

WARNING

WARNING indicates a hazardous situation which, if not avoided, could result in death or serious injury. The color associated with Warning is ORANGE.

M1170A

CAUTION

CAUTION, used with the safety alert symbol, indicates a hazardous situation which, if not avoided, could result in minor or moderate injury. The color associated with Caution is YELLOW.

M1171A

FAILURE TO FOLLOW DANGER, WARNING, AND CAUTION MESSAGES COULD RESULT IN DEATH OR SERIOUS INJURY.

Machine safety

NOTICE: Notice indicates a situation which, if not avoided, could result in machine or property damage. The color associated with Notice is BLUE.

Throughout this manual you will find the signal word Notice followed by special instructions to prevent machine or property damage. The word Notice is used to address practices not related to personal safety.

Information

NOTE: Note indicates additional information which clarifies steps, procedures, or other information in this manual.

Throughout this manual you will find the word Note followed by additional information about a step, procedure, or other information in the manual. The word Note is not intended to address personal safety or property damage.

Safety rules Ecology and the Environment

AXIAL-FLOW 7230 NA, AXIAL-FLOW 8230 NA, AXIAL-FLOW 9230 NA

Soil, air, and water are vital factors of agriculture and life in general. When legislation does not yet rule the treatment of some of the substances which are required by advanced technology, common sense should govern the use and disposal of products of a chemical and petrochemical nature.

NOTICE: *The following are recommendations which may be of assistance:*

- Become acquainted with and ensure that you understand the relative legislation applicable to your country.
- Where no legislation exists, obtain information from suppliers of oils, filters, batteries, fuels, antifreeze, cleaning agents, etc., with regard to their effect on man and nature and how to safely store, use and dispose of these substances.
- Agricultural consultants will, in many cases, be able to help you as well.

HELPFUL HINTS

- Avoid filling tanks using cans or inappropriate pressurized fuel delivery systems which may cause considerable spillage.
- In general, avoid skin contact with all fuels, oils, acids, solvents, etc. Most of them contain substances which may be harmful to your health.
- Modern oils contain additives. Do not burn contaminated fuels and or waste oils in ordinary heating systems.
- Avoid spillage when draining off used engine coolant mixtures, engine, gearbox and hydraulic oils, brake fluids, etc. Do not mix drained brake fluids or fuels with lubricants. Store them safely until they can be disposed of in a proper way to comply with local legislation and available resources.
- Modern coolant mixtures, i.e. antifreeze and other additives, should be replaced every two years. They should not be allowed to get into the soil but should be collected and disposed of properly.
- Do not open the air-conditioning system yourself. It contains gases which should not be released into the atmosphere. Your CASE IH AGRICULTURE dealer or air conditioning specialist has a special extractor for this purpose and will have to recharge the system properly.
- Repair any leaks or defects in the engine cooling or hydraulic system immediately.
- Do not increase the pressure in a pressurized circuit as this may lead to a component failure.
- Protect hoses during welding as penetrating weld splatter may burn a hole or weaken them, allowing the loss of oils, coolant, etc.



SERVICE MANUAL

Engine



**AXIAL-FLOW 7230 NA
AXIAL-FLOW 8230 NA
AXIAL-FLOW 9230 NA**

Engine - Remove

AXIAL-FLOW 7230

▲ WARNING

Avoid injury! Always do the following before lubricating, maintaining, or servicing the machine.

1. Disengage all drives.
 2. Engage parking brake.
 3. Lower all attachments to the ground, or raise and engage all safety locks.
 4. Shut off engine.
 5. Remove key from key switch.
 6. Switch off battery key, if installed.
 7. Wait for all machine movement to stop.
- Failure to comply could result in death or serious injury.

W0047A

▲ WARNING

Heavy objects!

Lift and handle all heavy components using lifting equipment with adequate capacity. Always support units or parts with suitable slings or hooks. Make sure the work area is clear of all bystanders. Failure to comply could result in death or serious injury.

W0398A

Prior operation:

Engine cooling system - Drain fluid (10.400) Deaeration tank - Remove (10.400) Engine hood - Remove (90.105) Radiator hoses - Remove (10.400) Air intake system - Remove (10.202) Fan and drive - Remove (10.414) Air conditioning - Service instruction (50.200) Fuel supply lines Low pressure - Remove (10.210) Aftercooler - Remove (10.310) Rotary screen drive belt or chain - Remove (10.418) Selective Catalytic Reduction (SCR) exhaust treatment - Remove (10.500) Diesel Exhaust Fluid (DEF)/AdBlue® lines - Remove (10.500) Diesel Exhaust Fluid (DEF)/AdBlue® delivery line to dosing injector - Remove (10.500) Selective Catalytic Reduction (SCR) muffler and catalyst - Remove (10.500) Central wire harness - Remove (55.100)

1. Attach a suitable chain to the front lift eye (1) at the front of the engine.

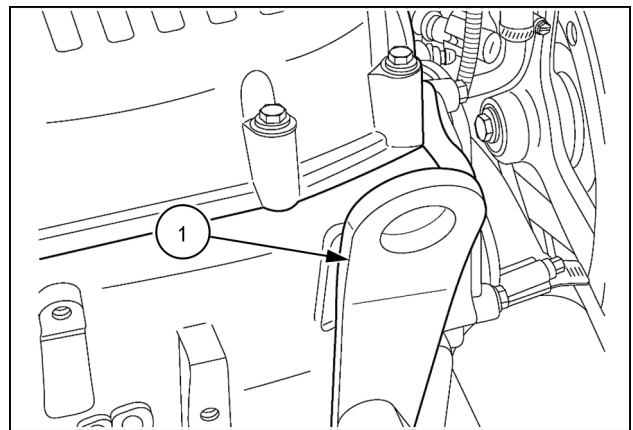

86070259 1

2. Attach a suitable chain to the back lift eye **(1)** at the rear of the engine.

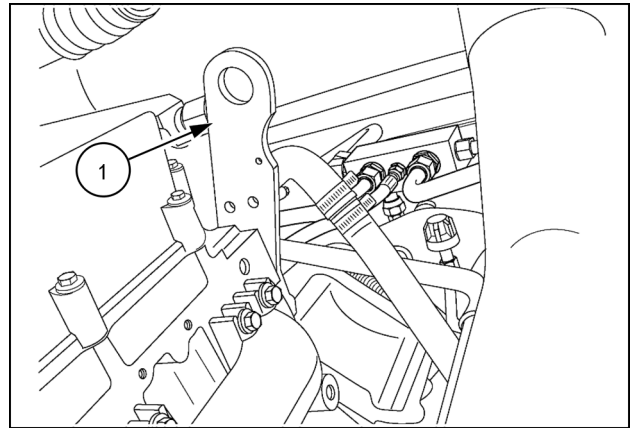

86070260 2

3. Connect the lift chain to a suitable lifting device.
4. Raise the lifting device enough to support the engine during removal of the engine mounting bolts.

NOTE: Illustration is for reference only. It may not be the actual engine.

NOTE: The lifting device should be rated for at least **907.2 kg (2000 lb)**. Allow enough clearance to lift the engine from the combine, approximately **7.0 m (23 ft)** from the floor.

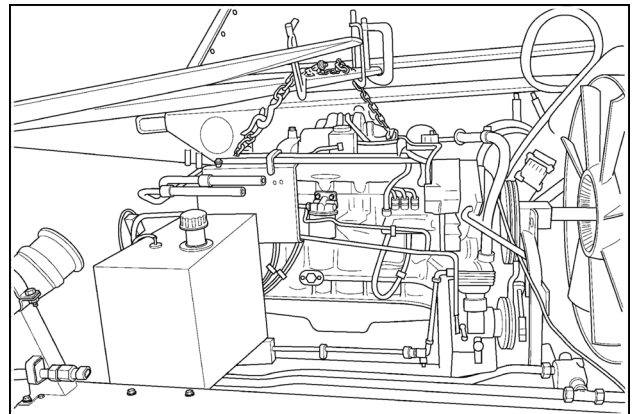

10013136 3

5. From the grain tank side of the engine, loosen the front, engine mounting bolt **(1)**. Do not remove the mounting bolts at this time.
6. From the platform side, loosen the front, engine mounting bolt **(1)**. Do not remove the mounting bolts at this time.

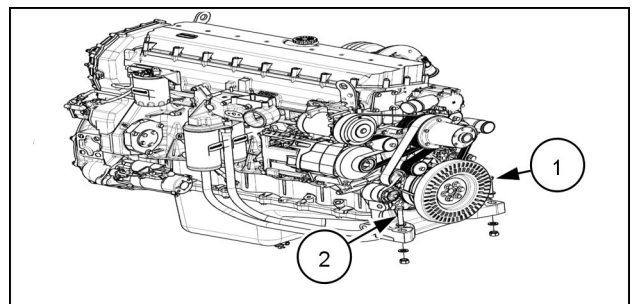

20086304 4

7. From the rear of the engine, loosen but do not remove all the bolts and washers **(1)** that couple the engine to the gearbox. There are twelve bolts and washers in total.
8. For safety reasons to the radiators, place a sheet of plywood, cut to size, in front of the cooler box for protection.
9. With the engine securely supported by the lifting device, remove all of the engine mounting bolts and the engine to the gearbox coupling bolts that were loosened in the previous steps.
10. Slide the engine towards the cooler box to disengage the flex plate from the gearbox input shaft.
11. Carefully lift the engine from the frame and remove from the combine.

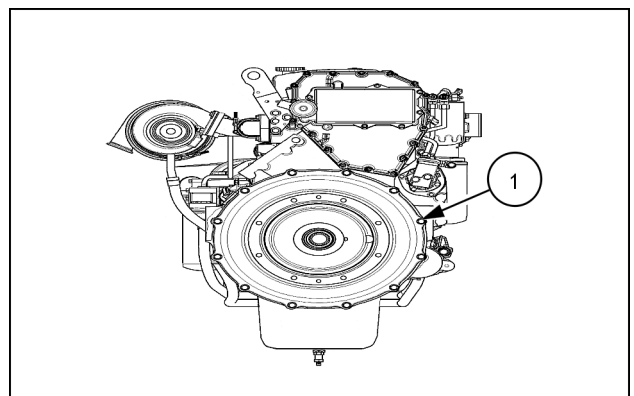

20107340 5

Next operation:

Engine - Install

AXIAL-FLOW 7230 NA

⚠ WARNING

Avoid injury! Always do the following before lubricating, maintaining, or servicing the machine.

1. Disengage all drives.
 2. Engage parking brake.
 3. Lower all attachments to the ground, or raise and engage all safety locks.
 4. Shut off engine.
 5. Remove key from key switch.
 6. Switch off battery key, if installed.
 7. Wait for all machine movement to stop.
- Failure to comply could result in death or serious injury.

W0047A

⚠ WARNING

Heavy objects!

Lift and handle all heavy components using lifting equipment with adequate capacity. Always support units or parts with suitable slings or hooks. Make sure the work area is clear of all bystanders.

Failure to comply could result in death or serious injury.

W0398A

Prior operation: Engine - Remove (10.001)

1. Before installing the engine, apply **LOCTITE® SILVER GRADE ANTI-SEIZE 767** to the input shaft **(1)** of the gearbox.

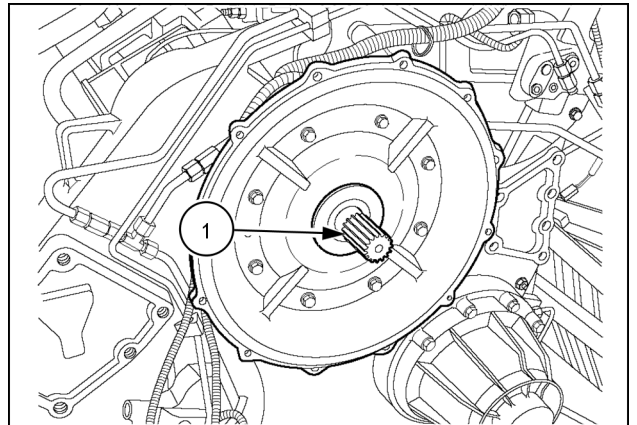

83070284 1

2. Attach a suitable chain to the front lift eye **(1)** at the front of the engine.

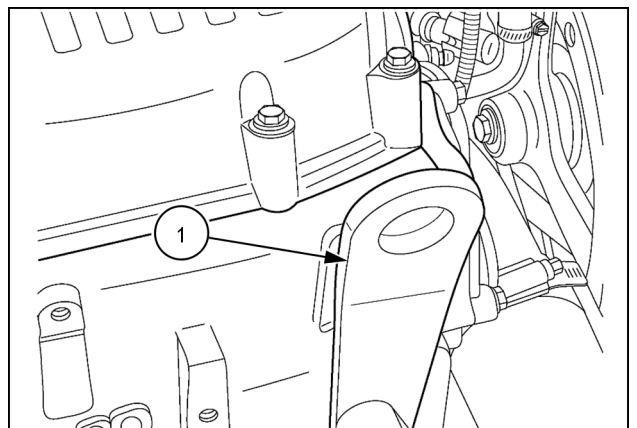

86070259 2

3. Attach a suitable chain to the back lift eye (1) at the rear of the engine.

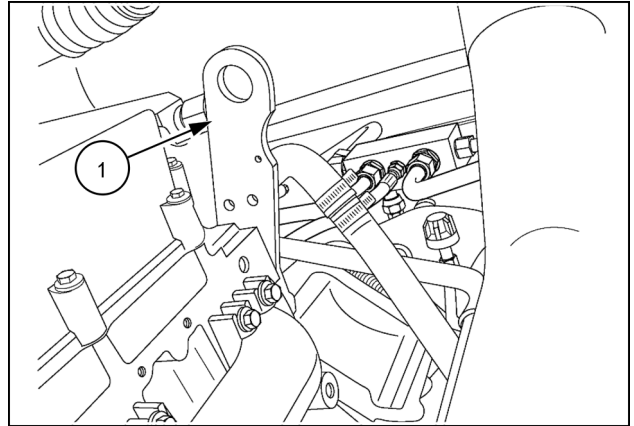

86070260 3

4. Connect the lift chain to a suitable lifting device.
5. Carefully lift the engine above the combine and lower into position in the frame.

NOTE: Illustration is for reference only. It may not be the actual engine.

NOTE: The lifting device should be rated for at least **907.2 kg (2000 lb)**. Allow enough clearance to lift the engine from the combine, approximately **907.2 kg (2000 lb)** from the floor.

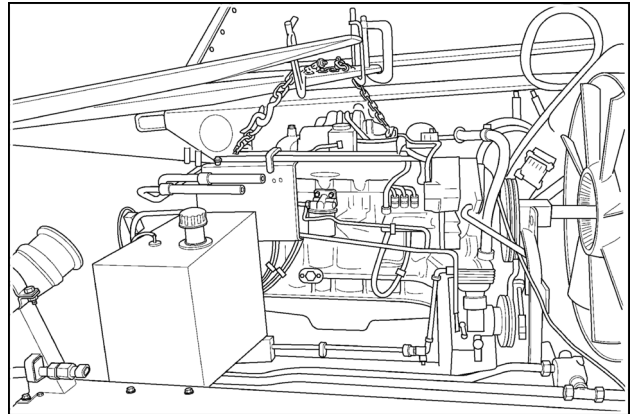

10013136 4

6. For safety reasons to the radiator, place a sheet of plywood, cut to size, in front of the radiator for protection.
7. Slide the engine towards the gearbox onto the gear box input shaft.
8. Align the holes of the gearbox with the engine and hand start a bolt with a washer (1) on each side of the coupling, going back and forth until all bolts with a washers are installed.

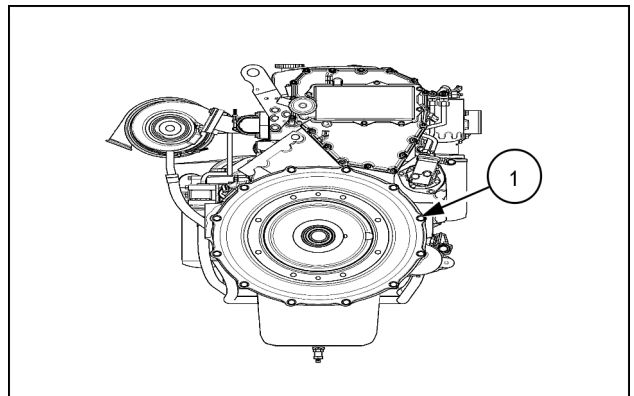

20107340 5

9. With the engine positioned in the frame, align the front mounting hole on the grain tank side and install the bolt with washers (1) into the mount. Do not tighten yet.

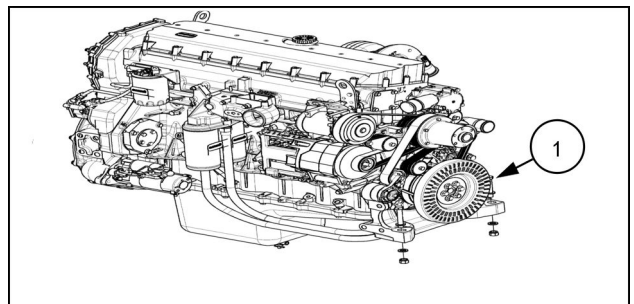

20086304 6

10. Align the front mounting hole on the platform side. Install the bolt with washers (1) into the mount.
11. Tighten and torque the front engine mounting bolts to **217 Nm (160.1 lb ft)**.
12. Tighten and torque the engine gearbox bolts to **41 - 51 Nm (30.2 - 37.6 lb ft)**.

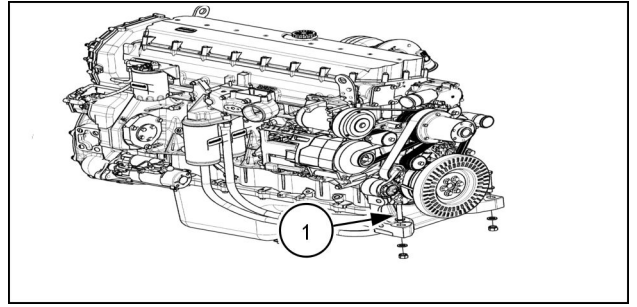

20086304 7

13. **Central wire harness - Install (55.100) Selective Catalytic Reduction (SCR) muffler and catalyst - Install (10.500) Diesel Exhaust Fluid (DEF)/AdBlue® lines - Install (10.500) Selective Catalytic Reduction (SCR) exhaust treatment - Install (10.500) Diesel Exhaust Fluid (DEF)/AdBlue® delivery line to dosing injector - Install (10.500) Rotary screen drive belt or chain - Install (10.418) Aftercooler - Install (10.310) Fuel supply lines Low pressure - Install (10.210) Air conditioning - Service instruction (50.200) Fan and drive - Install (10.414) Air intake system - Install (10.202) Radiator hoses - Install (10.400) Engine hood and panels - Install (90.100) Deaeration tank - Install (10.400) Engine cooling system - Filling (10.400)**
14. Connect the battery cables to the batteries (1) if they were removed or engage the battery connect switch (2).

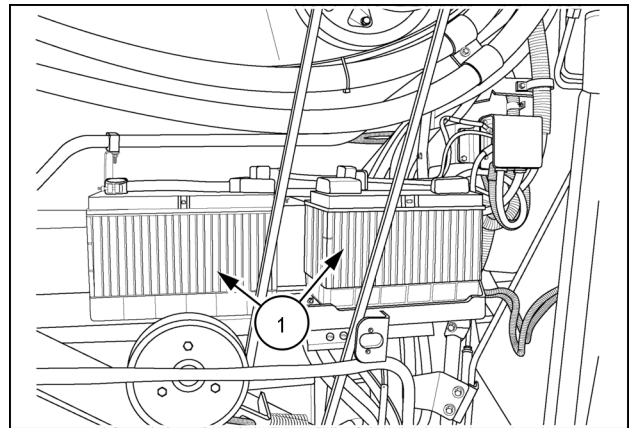

88063134 8

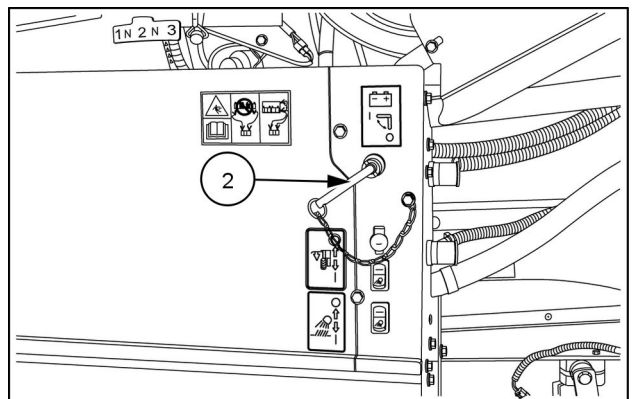

NHIL13AF00586AA 9

15. Disconnect the fuel pump wire connector (1) to disable the fuel pump (2).
16. Check the engine oil level and top off if necessary.
17. Crank the engine over for three ten second intervals. This will distribute lubricating oil to the engine operating systems and will allow oil pressure to be built before starting the engine.

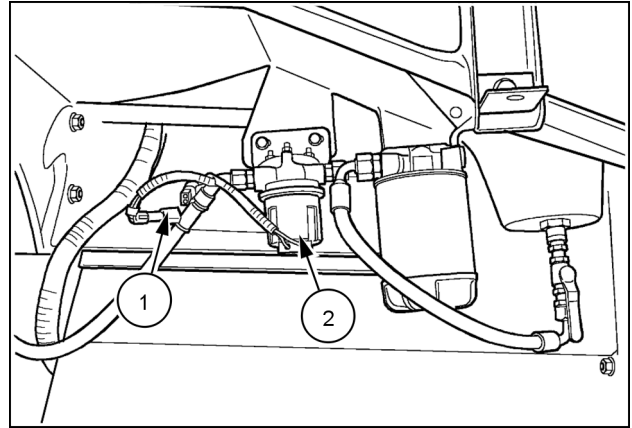

50030135 10

18. Connect the fuel pump wire connector (1) and bleed the air from fuel injection system, as described in the Operators manual.
19. Start the engine and check all hoses, fittings and clamps for leaks.

NOTICE: Monitor the instrument warning light bar at all times during initial engine start up to ensure the engine has proper oil pressure. Shut down the engine immediately if oil pressure is not adequate.

20. Ensure all electrical components are working properly.

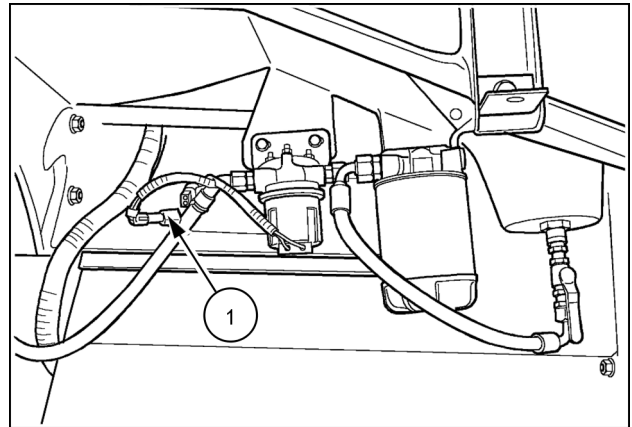

50030135 11

Engine - Remove

AXIAL-FLOW 8230, AXIAL-FLOW 9230

⚠ WARNING

Avoid injury! Always do the following before lubricating, maintaining, or servicing the machine.

1. Disengage all drives.
 2. Engage parking brake.
 3. Lower all attachments to the ground, or raise and engage all safety locks.
 4. Shut off engine.
 5. Remove key from key switch.
 6. Switch off battery key, if installed.
 7. Wait for all machine movement to stop.
- Failure to comply could result in death or serious injury.

W0047A

⚠ WARNING

Heavy objects!

Lift and handle all heavy components using lifting equipment with adequate capacity. Always support units or parts with suitable slings or hooks. Make sure the work area is clear of all bystanders.

Failure to comply could result in death or serious injury.

W0398A

Prior operation:

Engine cooling system - Drain fluid (10.400) Deaeration tank - Remove (10.400) Engine hood - Remove (90.105) Radiator hoses - Remove (10.400) Air intake system - Remove (10.202) Fan and drive - Remove (10.414) Air conditioning - Service instruction (50.200) Fuel supply lines Low pressure - Remove (10.210) Aftercooler - Remove (10.310) Rotary screen drive belt or chain - Remove (10.418) Selective Catalytic Reduction (SCR) exhaust treatment - Remove (10.500) Diesel Exhaust Fluid (DEF)/AdBlue® lines - Remove (10.500) Diesel Exhaust Fluid (DEF)/AdBlue® delivery line to dosing injector - Remove (10.500) Selective Catalytic Reduction (SCR) muffler and catalyst - Remove (10.500) Central wire harness - Remove (55.100)

1. Attach a suitable chain to the front lift eye (1) at the front of the engine.

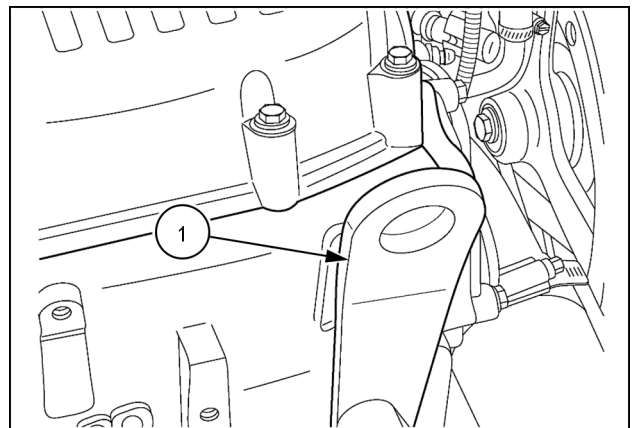

86070259 1

2. Attach a suitable chain to the back lift eye (1) at the rear of the engine.

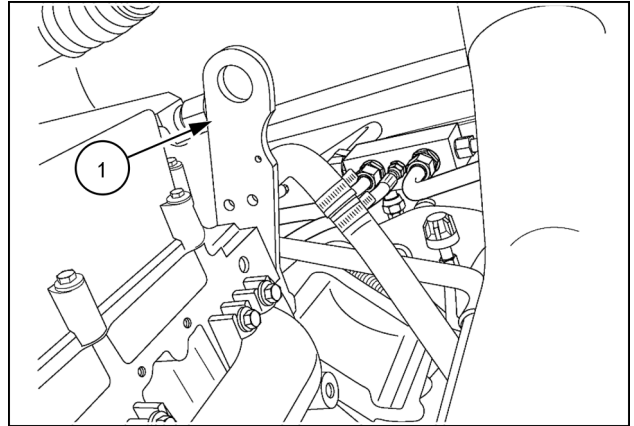

86070260 2

3. Connect the lift chain to a suitable lifting device.
4. Raise the lifting device enough to support the engine during removal of the engine mounting bolts.

NOTE: Illustration is for reference only. It may not be the actual engine.

NOTE: The lifting device should be rated for at least **907.2 kg (2000 lb)**. Allow enough clearance to lift the engine from the combine, approximately **7.0 m (23 ft)** from the floor.

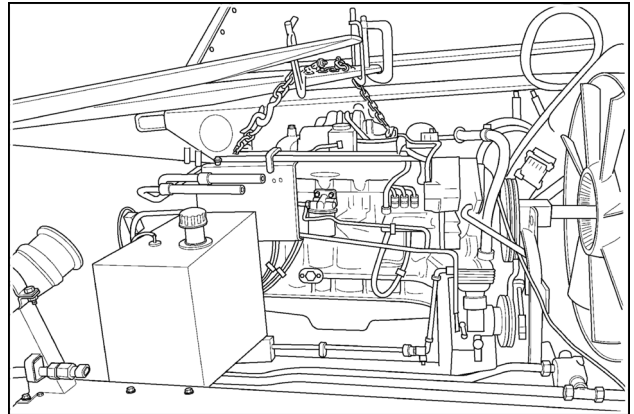

10013136 3

5. From the grain tank side of engine, loosen the front two engine mounting bolts (1). Do not remove the mounting bolts at this time.

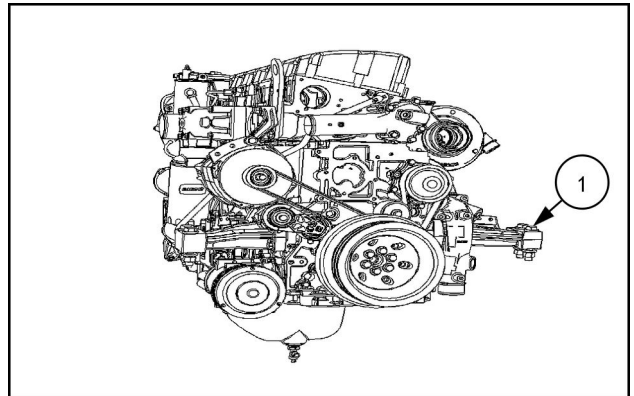

20107342 4

6. From the platform side, loosen the two front, engine mounting bolts (1). Do not remove the mounting bolts at this time.

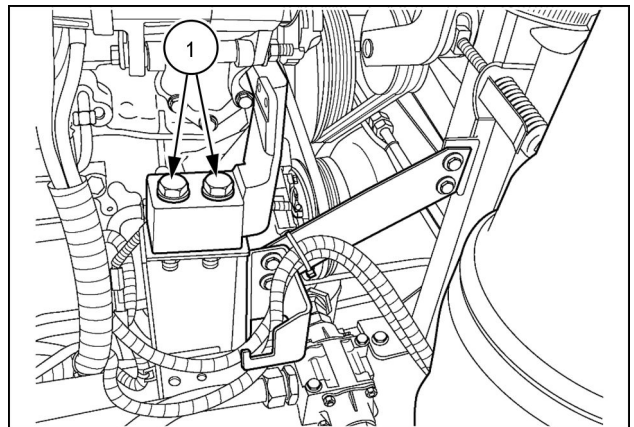

86070235 5

7. Loosen but do not remove all the bolts and washers **(1)** that couple the engine to the gearbox. There are twelve bolts and washers in total.
8. For safety reasons to the radiators, place a sheet of plywood, cut to size, in front of the cooler box for protection.
9. With the engine securely supported by the lifting device, remove all of the engine mounting bolts and the engine to the gearbox coupling bolts that were loosened in the previous steps.
10. Slide the engine towards the cooler box to disengage the flex plate from the gearbox input shaft.
11. Carefully lift the engine from the frame and remove from the combine.

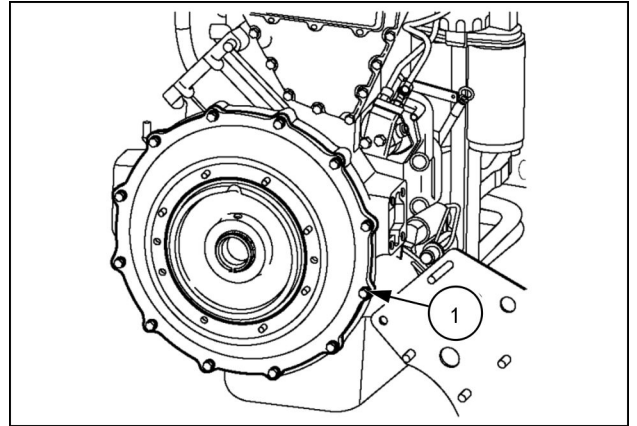

83090610 6

Next operation:
Engine - Install (10.001).

Engine - Install

AXIAL-FLOW 8230 NA, AXIAL-FLOW 9230 NA

Prior operation:

Engine - Remove (10.001)

1. Before installing the engine, apply **LOCTITE® SILVER GRADE ANTI-SEIZE 767** to the input shaft **(1)** of the gearbox.

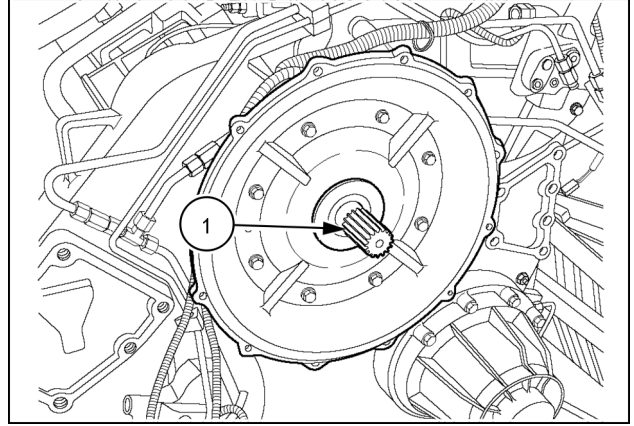

83070284 1

2. Attach a suitable chain to the front lift eye **(1)** at the front of the engine.

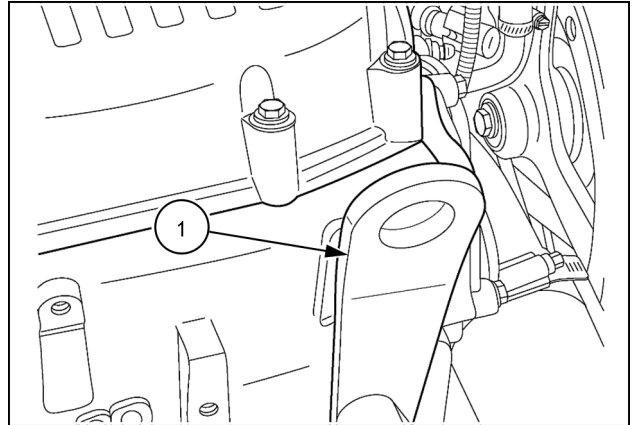

86070259 2

3. Attach a suitable chain to the back lift eye **(1)** at the rear of the engine.

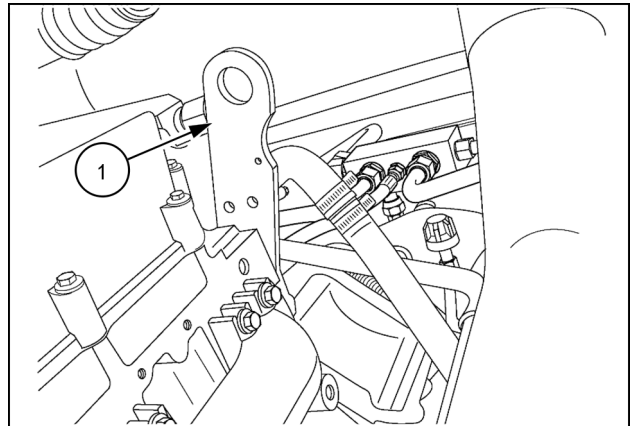

86070260 3



Suggest:

If the above button click is invalid.

Please download this document

first, and then click the above link

to download the complete manual.

Thank you so much for reading

4. Connect the lift chain to a suitable lifting device.
5. Carefully lift the engine above the combine and lower into position in the frame.

NOTE: Illustration is for reference only. It may not be the actual engine.

NOTE: The lifting device should be rated for at least **907.2 kg (2000 lb)**. Allow enough clearance to lift the engine from the combine, approximately **907.2 kg (2000 lb)** from the floor.

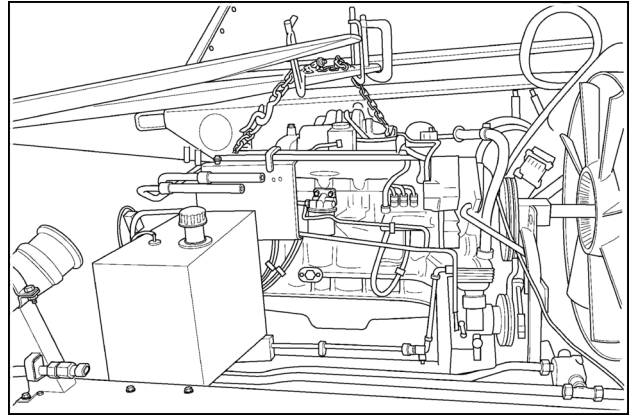

10013136 4

6. For safety reasons to the radiator, place a sheet of plywood, cut to size, in front of the radiator for protection.
7. Slide the engine towards the gearbox onto the gear box input shaft.
8. Align the holes of the gearbox with the engine and hand start a bolt with a washer (1) on each side of the coupling, going back and forth until all bolts with a washer are installed.

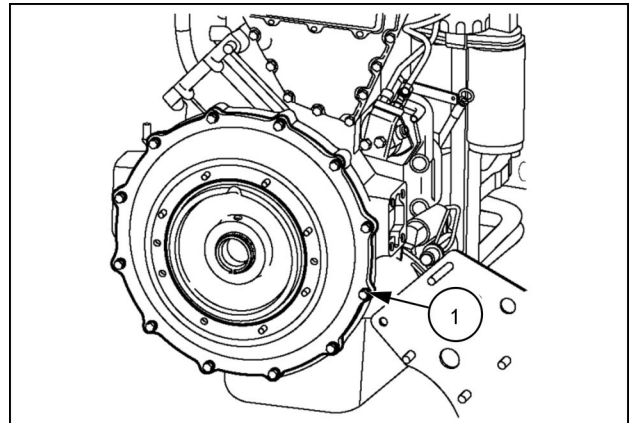

83090610 5

9. With the engine positioned in the frame, align the two front mounting holes on the grain tank side. Install the mounting hardware (1) into the mount. Do not tighten yet.

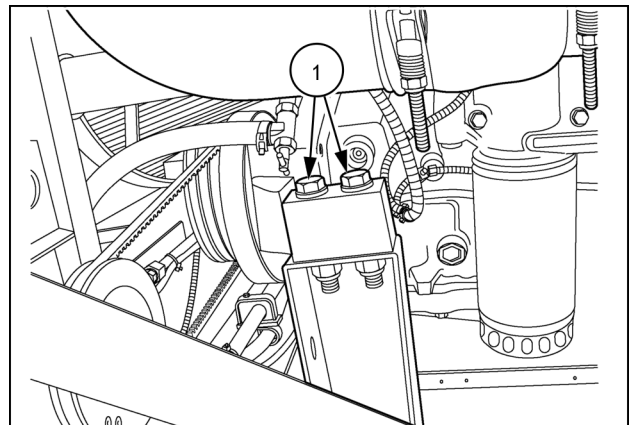

86070234 6

<https://www.ebooklibonline.com>

Hello dear friend!

Thank you very much for reading.

Enter the link into your browser.

The full manual is available for immediate download.

<https://www.ebooklibonline.com>