

AXIAL-FLOW® 5140
AXIAL-FLOW® 6140
AXIAL-FLOW® 7140
Tier 2
Combine

PIN YFG014001 and above

SERVICE MANUAL

Part number 47956016

1st edition English

January 2016

© 2016 CNH Industrial America LLC. All Rights Reserved.

CASE IH
AGRICULTURE

Link Product / Engine

Product	Market Product	Engine
AXIAL-FLOW® 5140 PIN YFG014001 - [YFG014001 -]	Middle East Africa	F4HFA613F*E003
AXIAL-FLOW® 5140 PIN YFG014001 - [YFG014001 -]	Australia New Zealand	F4HFA613F*E003
AXIAL-FLOW® 5140 PIN YFG014001 - [YFG014001 -]	Asia Pacific	F4HFA613F*E003
AXIAL-FLOW® 6140 YFG014001- [YFG014001 -]	Asia Pacific	F2CFA6135*E
AXIAL-FLOW® 6140 YFG014001- [YFG014001 -]	Middle East Africa	F2CFA6135*E
AXIAL-FLOW® 6140 YFG014001- [YFG014001 -]	Australia New Zealand	F2CFA6135*E
AXIAL-FLOW® 7140 PIN YFG014001- [YFG014001 -]	Middle East Africa	F2CFA613A*E
AXIAL-FLOW® 7140 PIN YFG014001- [YFG014001 -]	Australia New Zealand	F2CFA613A*E
AXIAL-FLOW® 7140 PIN YFG014001- [YFG014001 -]	Asia Pacific	F2CFA613A*E

Contents

INTRODUCTION

Engine	10
[10.001] Engine and crankcase	10.1
[10.202] Air cleaners and lines	10.2
[10.206] Fuel filters	10.3
[10.210] Lift pump and lines	10.4
[10.216] Fuel tanks	10.5
[10.254] Intake and exhaust manifolds and muffler	10.6
[10.304] Engine lubrication system.....	10.7
[10.310] Aftercooler.....	10.8
[10.400] Engine cooling system	10.9
[10.408] Oil cooler and lines.....	10.10
[10.414] Fan and drive	10.11
[10.419] Stationary air screen	10.12
[10.450] Engine air compressor	10.13
[10.500] Selective Catalytic Reduction (SCR) exhaust treatment.....	10.14
Main gearbox and drive	14
[14.100] Main gearbox and drive	14.1
Transmission	21
[21.100] Mechanical transmission lubrication system	21.1
[21.114] Mechanical transmission	21.2
[21.140] Mechanical transmission internal components.....	21.3
[21.145] Gearbox internal components.....	21.4
[21.182] Differential.....	21.5
Front axle system	25
[25.100] Powered front axle	25.1

<https://www.ebooklibonline.com>

Hello dear friend!

Thank you very much for reading.

Enter the link into your browser.

The full manual is available for immediate download.

<https://www.ebooklibonline.com>

[25.108] Final drive hub, steering knuckles, and shafts	25.2
[25.310] Final drives	25.3
Rear axle system.....	27
[27.124] Final drive hub, steering knuckles, and shafts	27.1
[27.450] Rear-powered steerable axle	27.2
[27.550] Non-powered rear axle.....	27.3
Hydrostatic drive.....	29
[29.100] Transmission and steering hydrostatic control	29.1
[29.202] Hydrostatic transmission	29.2
[29.204] Reservoir, cooler, and lines	29.3
[29.218] Pump and motor components.....	29.4
Brakes and controls	33
[33.110] Parking brake or parking lock	33.1
[33.202] Hydraulic service brakes	33.2
Hydraulic systems.....	35
[35.000] Hydraulic systems.....	35.1
[35.102] Pump control valves.....	35.2
[35.106] Variable displacement pump	35.3
[35.220] Auxiliary hydraulic pump	35.4
[35.300] Reservoir, cooler, and filters.....	35.5
[35.322] Regulated/Low pressure system	35.6
[35.359] Main control valve.....	35.7
[35.410] Header or attachment height system	35.8
[35.518] Reel control system	35.9
[35.536] Crop processor system	35.10
Steering.....	41
[41.101] Steering control	41.1
[41.106] Tie rods.....	41.2

[41.200] Hydraulic control components	41.3
[41.206] Pump	41.4
[41.216] Cylinders	41.5
[41.432] Autoguidance steering	41.6
Wheels	44
[44.511] Front wheels	44.1
Cab climate control	50
[50.100] Heating	50.1
[50.104] Ventilation	50.2
[50.200] Air conditioning	50.3
[50.300] Cab pressurizing system	50.4
Electrical systems	55
[55.000] Electrical system	55.1
[55.010] Fuel injection system	55.2
[55.011] Fuel tank system	55.3
[55.012] Engine cooling system	55.4
[55.013] Engine oil system	55.5
[55.014] Engine intake and exhaust system	55.6
[55.015] Engine control system	55.7
[55.019] Hydrostatic drive control system	55.8
[55.020] Transmission speed sensors	55.9
[55.023] Transmission position sensors	55.10
[55.024] Transmission control system	55.11
[55.030] Service brake electrical system	55.12
[55.031] Parking brake electrical system	55.13
[55.036] Hydraulic system control	55.14
[55.046] Rear axle control system	55.15
[55.047] Steering control system	55.16
[55.050] Heating, Ventilation, and Air-Conditioning (HVAC) control system	55.17

[55.100] Harnesses and connectors	55.18
[55.201] Engine starting system	55.19
[55.202] Cold start aid	55.20
[55.301] Alternator	55.21
[55.302] Battery	55.22
[55.404] External lighting	55.23
[55.405] External lighting switches and relays	55.24
[55.408] Warning indicators, alarms, and instruments	55.25
[55.421] Feeding control system	55.26
[55.422] Ejection/Unloading control system	55.27
[55.423] Cleaning control system.....	55.28
[55.426] Harvest material flow control system.....	55.29
[55.510] Cab or platform harnesses and connectors	55.30
[55.511] Light harnesses	55.31
[55.512] Cab controls.....	55.32
[55.518] Wiper and washer system.....	55.33
[55.520] Cab harvesting controls	55.34
[55.525] Cab engine controls	55.35
[55.624] Residue handling control.....	55.36
[55.628] Threshing electrical control	55.37
[55.640] Electronic modules	55.38
[55.661] Cab header controls.....	55.39
[55.662] Header height control	55.40
[55.670] Header leveling control.....	55.41
[55.675] Reel speed and position control.....	55.42
[55.680] Autopilot/Autoguidance	55.43
[55.780] Shaker shoe leveling system control.....	55.44
[55.785] Precision farming system	55.45

[55.834] Sieve electric control	55.46
[55.836] Rotary separator control	55.47
[55.911] Global Positioning System (GPS)	55.48
[55.988] Selective Catalytic Reduction (SCR) electrical system	55.49
[55.DTC] FAULT CODES	55.50
Product feeding	60
[60.101] Feed roll	60.1
[60.105] Floating roll, feed chain, and drive	60.2
[60.110] Feeder housing	60.3
[60.112] Stone trapping system	60.4
[60.120] Header drive system	60.5
[60.122] Length-of-cut gearbox	60.6
[60.150] Feeder drive system	60.7
[60.165] Feeder reverse system	60.8
[60.500] Gearbox housing	60.9
Threshing	66
[66.101] Concave conveyor plate	66.1
[66.110] Concave control system	66.2
[66.260] Threshing mechanism drive system	66.3
[66.321] Drum/Rotor variator with electrical control	66.4
[66.330] Drum	66.5
[66.331] Rotor	66.6
Separation	72
[72.220] Discharge beater	72.1
[72.410] Rotary separator drive system	72.2
[72.420] Rotary separator	72.3
Residue handling	73
[73.210] Straw chopper drive system	73.1

[73.230] Straw chopper	73.2
[73.230] Straw chopper	73.3
[73.430] Straw spreader	73.4
Cleaning	74
[74.000] Cleaning	74.1
[74.101] Cleaning drive systems	74.2
[74.114] Upper shaker shoe	74.3
[74.118] Lower shaker shoe	74.4
[74.130] Fan housing	74.5
[74.136] Fan drive system	74.6
[74.140] Tailings return system	74.7
Crop storage / Unloading	80
[80.101] Clean grain elevator	80.1
[80.150] Grain tank	80.2
[80.175] Grain tank unload drive system	80.3
[80.180] Grain tank unload	80.4
Platform, cab, bodywork, and decals	90
[90.100] Engine hood and panels	90.1
[90.105] Machine shields and guards	90.2
[90.124] Pneumatically-adjusted operator seat	90.3
[90.150] Cab	90.4
[90.151] Cab interior	90.5



INTRODUCTION

Foreword - Important notice regarding equipment servicing

All repair and maintenance work listed in this manual must be carried out only by qualified dealership personnel, strictly complying with the instructions given, and using, whenever possible, the special tools.

Anyone who performs repair and maintenance operations without complying with the procedures provided herein shall be responsible for any subsequent damages.

The manufacturer and all the organizations of its distribution chain, including - without limitation - national, regional, or local dealers, reject any responsibility for damages caused by parts and/or components not approved by the manufacturer, including those used for the servicing or repair of the product manufactured or marketed by the manufacturer. In any case, no warranty is given or attributed on the product manufactured or marketed by the manufacturer in case of damages caused by parts and/or components not approved by the manufacturer.

The manufacturer reserves the right to make improvements in design and changes in specifications at any time without notice and without incurring any obligation to install them on units previously sold. Specifications, descriptions, and illustrative material herein are as accurate as known at time of publication but are subject to change without notice.

In case of questions, refer to your CASE IH Sales and Service Networks.

Safety rules - Ecology and the environment

AXIAL-FLOW® 5140	ANZ --- APAC --- MEA
AXIAL-FLOW® 6140	ANZ --- APAC --- MEA
AXIAL-FLOW® 7140	ANZ --- APAC --- MEA

Soil, air, and water quality is important for all industries and life in general. When legislation does not yet rule the treatment of some of the substances that advanced technology requires, sound judgment should govern the use and disposal of products of a chemical and petrochemical nature.

Familiarize yourself with the relative legislation applicable to your country, and make sure that you understand this legislation. Where no legislation exists, obtain information from suppliers of oils, filters, batteries, fuels, anti-freeze, cleaning agents, etc., with regard to the effect of these substances on man and nature and how to safely store, use, and dispose of these substances.

Helpful hints

- Avoid the use of cans or other inappropriate pressurized fuel delivery systems to fill tanks. Such delivery systems may cause considerable spillage.
- In general, avoid skin contact with all fuels, oils, acids, solvents, etc. Most of these products contain substances that may be harmful to your health.
- Modern oils contain additives. Do not burn contaminated fuels and or waste oils in ordinary heating systems.
- Avoid spillage when you drain fluids such as used engine coolant mixtures, engine oil, hydraulic fluid, brake fluid, etc. Do not mix drained brake fluids or fuels with lubricants. Store all drained fluids safely until you can dispose of the fluids in a proper way that complies with all local legislation and available resources.
- Do not allow coolant mixtures to get into the soil. Collect and dispose of coolant mixtures properly.
- The air-conditioning system contains gases that should not be released into the atmosphere. Consult an air-conditioning specialist or use a special extractor to recharge the system properly.
- Repair any leaks or defects in the engine cooling system or hydraulic system immediately.
- Do not increase the pressure in a pressurized circuit as this may lead to a component failure.
- Protect hoses during welding. Penetrating weld splatter may burn a hole or weaken hoses, allowing the loss of oils, coolant, etc.

Battery recycling

Batteries and electric accumulators contain several substances that can have a harmful effect on the environment if the batteries are not properly recycled after use. Improper disposal of batteries can contaminate the soil, groundwater, and waterways. CASE IH strongly recommends that you return all used batteries to a CASE IH dealer, who will dispose of the used batteries or recycle the used batteries properly. In some countries, this is a legal requirement.



Mandatory battery recycling

NOTE: The following requirements are mandatory in Brazil.

Batteries are made of lead plates and a sulfuric acid solution. Because batteries contain heavy metals such as lead, CONAMA Resolution 401/2008 requires you to return all used batteries to the battery dealer when you replace any batteries. Do not dispose of batteries in your household garbage.

Points of sale are obliged to:

- Accept the return of your used batteries
- Store the returned batteries in a suitable location
- Send the returned batteries to the battery manufacturer for recycling

Safety rules - Personal safety

AXIAL-FLOW® 5140	ANZ --- APAC --- MEA
AXIAL-FLOW® 6140	ANZ --- APAC --- MEA
AXIAL-FLOW® 7140	ANZ --- APAC --- MEA

Carefully study these precautions, and those included in the external attachment operators manual, and insist that they be followed by those working with and for you.

1. Thoroughly read and understand this manual and the attachment Operator's Manual before operating this or any other equipment.
2. Be sure all people and pets are clear of the machine before starting. Sound the horn, if equipped, three times before starting engine.
3. Only the operator should be on the machine when in operation. Never allow anyone to climb on to the machine while it is in motion. If the machine is equipped with an Instructors Seat, this must only be used for training purposes. Passengers must not be allowed to use the Instructors Seat.
4. Keep all shields in place. Never work around the machine or any of the attachments while wearing loose clothing that might catch on moving parts.
5. Observe the following precautions whenever lubricating the machine or making adjustments.
 - Disengage all clutching levers or switches.
 - Lower the attachment, if equipped, to the ground or raise the attachment completely and engage the cylinder safety locks. Completing these actions will prevent the attachment from lowering unexpectedly.
 - Engage the parking brake.
 - Shut off the engine and remove the key.
 - Wait for all machine movement to stop before leaving the operators platform.
6. Always keep the machine in gear while travelling downhill.
7. The machine should always be equipped with sufficient front or rear axle weight for safe operation.
8. Under some field conditions, more weight may be required at the front or rear axle for adequate stability. This is especially important when operating in hilly conditions or/when using heavy attachments.
9. Always lower the attachment, shut off the engine, set the parking brake, engage the transmission gears, remove the key and wait for all machine movement to stop before leaving the operators platform.
10. If the attachment or machine should become obstructed or plugged; set the parking brake, shut off the engine and remove the key, engage the transmission gears, wait for all machine or attachment motion to come to a stop, before leaving the operators platform to removing the obstruction or plug.
11. Never disconnect or make any adjustments to the hydraulic system unless the machine and/or the attachment is lowered to the ground or the safety lock(s) is in the engaged position.
12. Use of the flashing lights is highly recommended when operating on a public road.
13. When transporting on a road or highway, use accessory lights and devices for adequate warning to the operators of other vehicles. In this regard, check local government regulations. Various safety lights and devices are available from your CASE IH dealer.
14. Practice safety 365 days a year.
15. Keep all your equipment in safe operating condition.
16. Keep all guards and safety devices in place.
17. Always set the parking brake, shut off the engine and remove the key, engage the transmission gears, wait for all machine or attachment motion to come to a stop, before leaving the operators platform to service the machine and attachment.
18. Remember: A careful operator is the best insurance against an accident.
19. Extreme care should be taken in keeping hands and clothing away from moving parts.



SERVICE MANUAL

Engine

AXIAL-FLOW® 5140 [YFG014001 -]
AXIAL-FLOW® 6140 [YFG014001 -]
AXIAL-FLOW® 7140 [YFG014001 -]

Contents

Engine - 10

[10.001] Engine and crankcase	10.1
[10.202] Air cleaners and lines	10.2
[10.206] Fuel filters	10.3
[10.210] Lift pump and lines	10.4
[10.216] Fuel tanks	10.5
[10.254] Intake and exhaust manifolds and muffler	10.6
[10.304] Engine lubrication system.....	10.7
[10.310] Aftercooler.....	10.8
[10.400] Engine cooling system	10.9
[10.408] Oil cooler and lines.....	10.10
[10.414] Fan and drive	10.11
[10.419] Stationary air screen	10.12
[10.450] Engine air compressor	10.13
[10.500] Selective Catalytic Reduction (SCR) exhaust treatment.....	10.14

Engine - Remove engine oil drain line and drain valve

Prior operation:
Engine - Drain fluid (10.001)

5140

1. Remove the engine oil drain hose (1) from the elbow connector (2) at oil pan and at the oil drain valve (3).

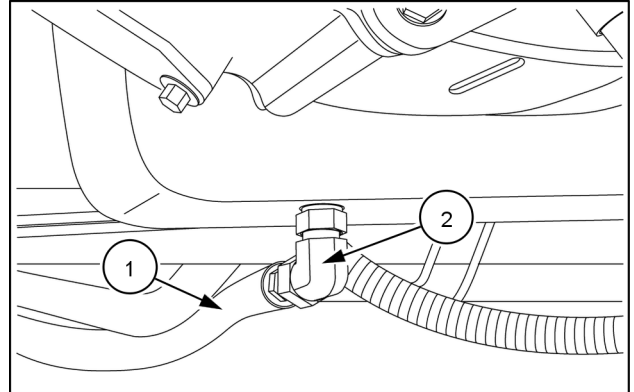

NH12AF001332A 1

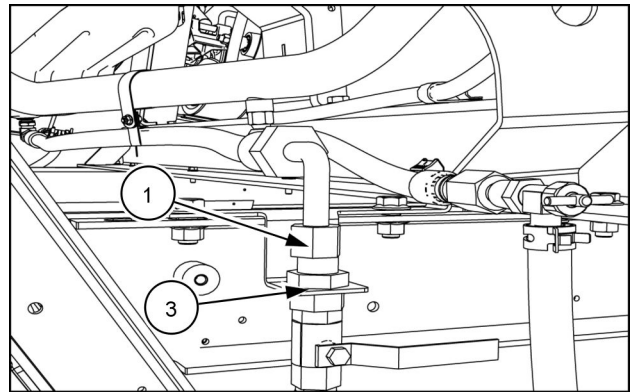

NHIL14AF00236AA 2

2. Remove the elbow connector from oil pan.

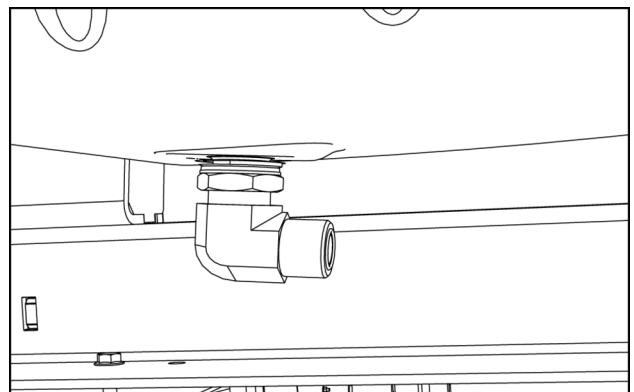

NHIL14AF00237AA 3

3. Remove the drain valve (1) from the bulkhead support bracket (2) by removing the lock nut (3).

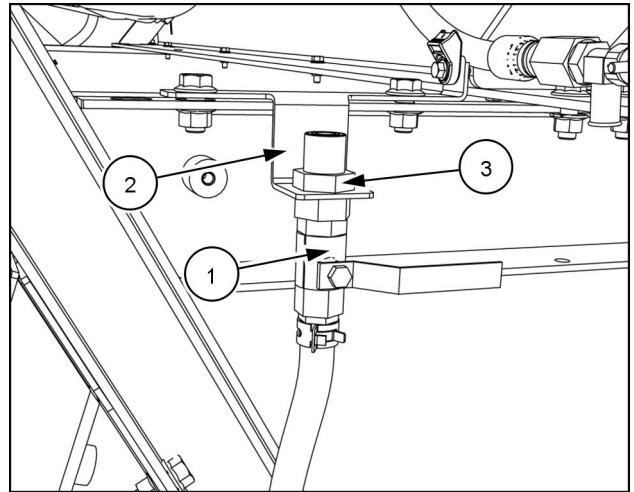

NHIL14AF00235AA 4

6140 and 7140

4. Remove the engine oil drain hose (1) from the oil pan and at the oil drain valve (2).

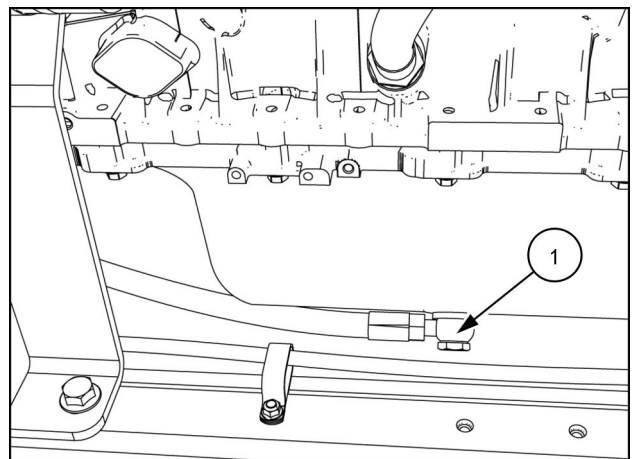

NHIL14AF00234AA 5

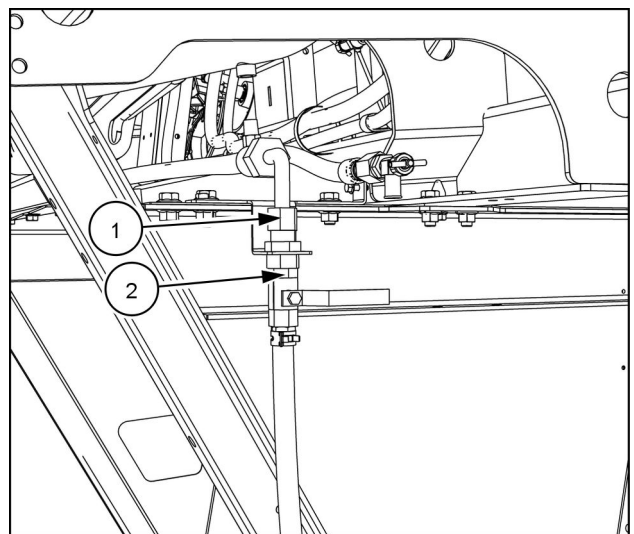

NHIL13AF02228AA 6

5. Remove the drain valve (1) from the bulkhead support bracket (2) by removing the lock nut (3).

NOTE: The drain valve is located behind the SAS (stationary air screen).

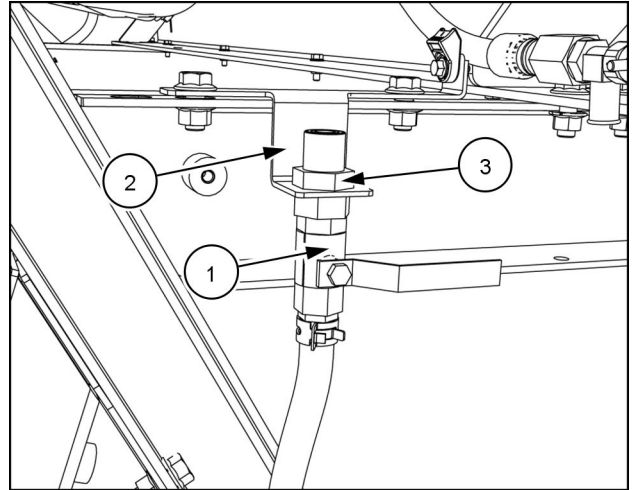

NHIL14AF00235AA 7

Engine - Install engine oil drain line and drain valve

5140

1. Install the oil drain valve (1) to the bulkhead support bracket (2). Install the lock nut (3) and tighten to **60 - 68 N·m (44 - 50 lb ft)**.

NOTE: The oil drain valve is located behind the SAS (stationary air screen).

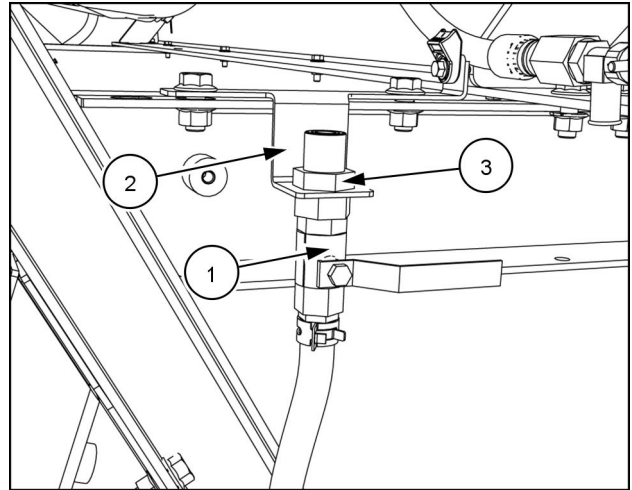

NHIL14AF00235AA 1

NOTE: Before installing the 90 ° connector (1), check the O-rings for any wear and replace if needed. Make sure the O-rings are lubricated with clean oil or petroleum jelly before installing.

2. Install the 90 ° connector (1) to the oil pan and position it with the hose connection facing the cooler box. Tighten the connector to **60 - 66 N·m (44 - 49 lb ft)**

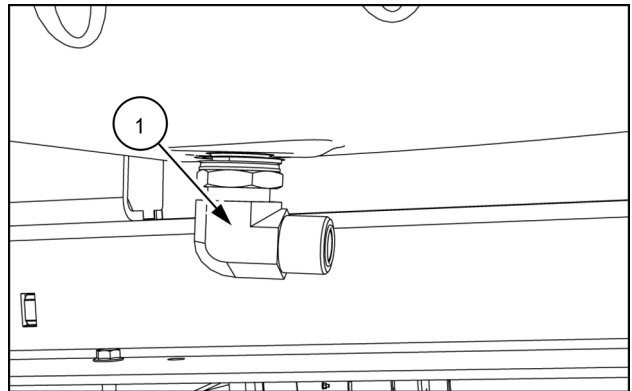

NHIL14AF00237AA 2

3. Install the engine oil drain hose (1) to the 90 ° connector at oil pan. Torque the fitting (2) at connector to **60 - 68 N·m (44 - 50 lb ft)**.

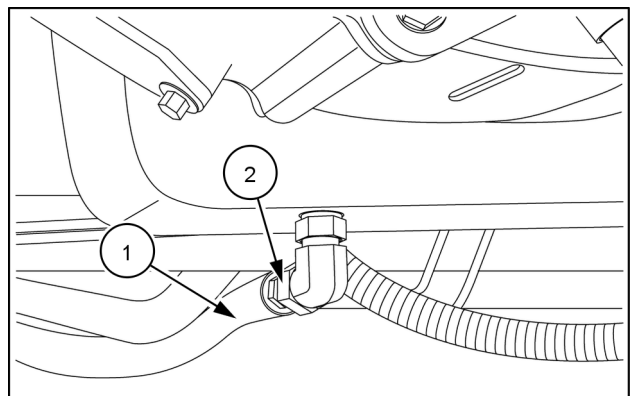

NH12AF001332A 3

4. Install the other end of hose (1) to the drain valve (2). Tighten the fitting to **60 - 68 N·m (44 - 50 lb ft)**

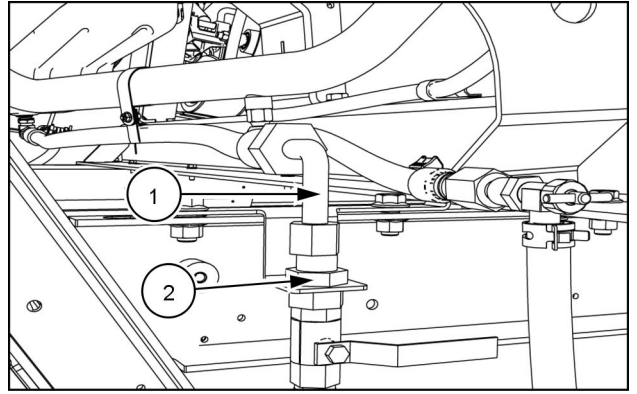

NHIL14AF00236AA 4

6140 and 7140

5. Install the drain valve (1) to the bulkhead support bracket (2). Install the lock nut (3) and tighten to **60 - 68 N·m (44 - 50 lb ft)**.

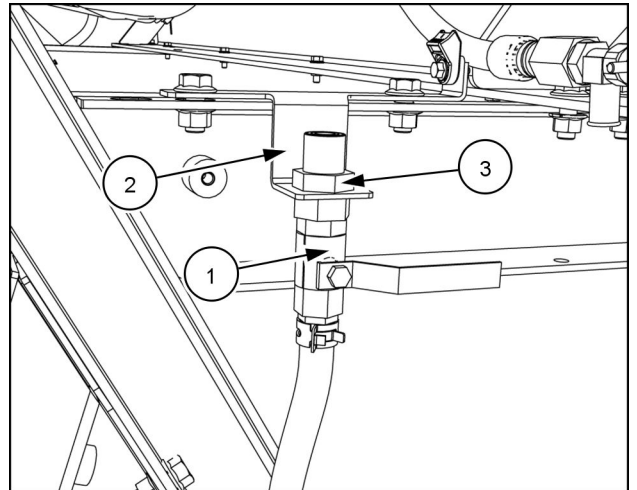

NHIL14AF00235AA 5

6. Install the engine oil drain hose (1) to the oil pan. Torque the banjo bolt (2) at the oil pan to **60 - 66 N·m (44 - 49 lb ft)**

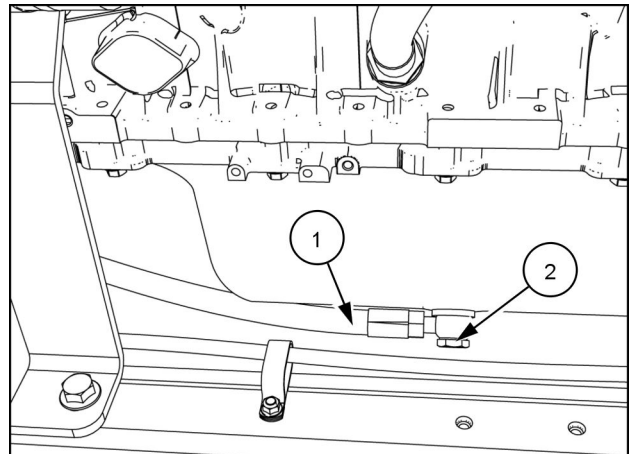

NHIL14AF00234AA 6

7. Install the other end of hose (1) to the drain valve (2).
Tighten the fitting to **60 - 68 N·m (44 - 50 lb ft)**

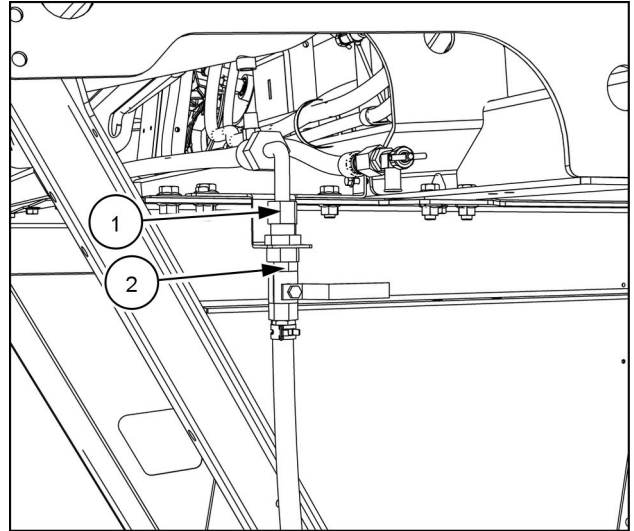

NHIL13AF02228AA 7

Next operation:
Engine - Filling engine oil (10.001)

Engine - Change fluid – Maintenance Chart – Recommended operating temperature range

AXIAL-FLOW® 5140	ANZ --- APAC --- MEA
AXIAL-FLOW® 6140	ANZ --- APAC --- MEA
AXIAL-FLOW® 7140	ANZ --- APAC --- MEA

CJ-4 and CI-4 oils

	(H)	0W-40 CJ-4 UNITEK to MAT3521									
	(H)	API CI-4 0W-40									
		(H)	API CI-4 10W-30								
		(H)	10W-40 CJ-4 UNITEK to CNH MAT3521								
		(H)	API CI-4 10W-40								
			(H)	15W-40 CJ-4 UNITEK to CNH MAT3521							
			(H)	API CI-4 15W-40							
				API CI-4 20W-50							
-40 °C -40 °F	-30 °C -22 °F	-20 °C -4 °F	-10 °C 14 °F	0 °C 32 °F	10 °C 50 °F	20 °C 68 °F	30 °C 86 °F	40 °C 104 °F	50 °C 122 °F		
(H) Engine oil pan or coolant block heater recommended in this range											

Engine - Remove engine serpentine belt

AXIAL-FLOW® 5140 PIN YFG014001 - [YFG014001 -]

ANZ --- APAC --- MEA

⚠ WARNING

Avoid injury! Always do the following before lubricating, maintaining, or servicing the machine.

1. Disengage all drives.
 2. Engage parking brake.
 3. Lower all attachments to the ground, or raise and engage all safety locks.
 4. Shut off engine.
 5. Remove key from key switch.
 6. Switch off battery key, if installed.
 7. Wait for all machine movement to stop.
- Failure to comply could result in death or serious injury.**

W0047A

1. Open the engine and rotor drive access doors.

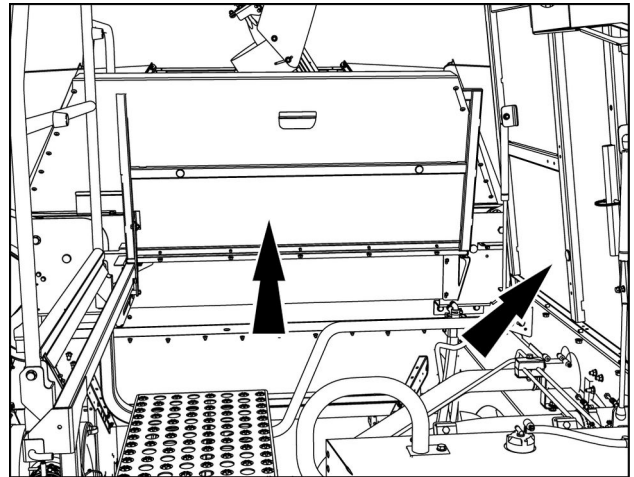

NH14AF00372AA 1

2. Remove the fan access panel (1) from the engine compartment.

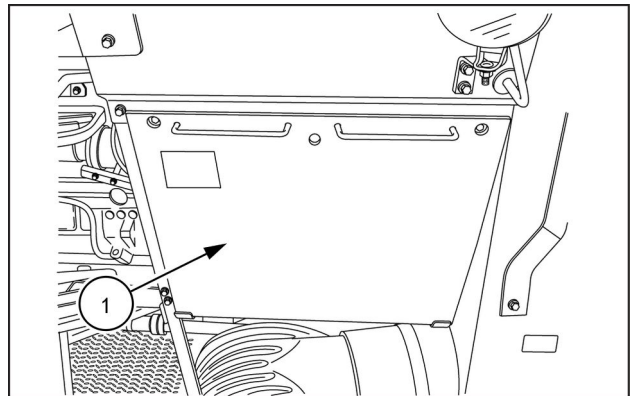

NH12AF00292A 2

3. Use a **0.5 in** ratchet wrench on the belt tensioner **(1)** to relieve the tension on the serpentine belt and remove it from the engine.

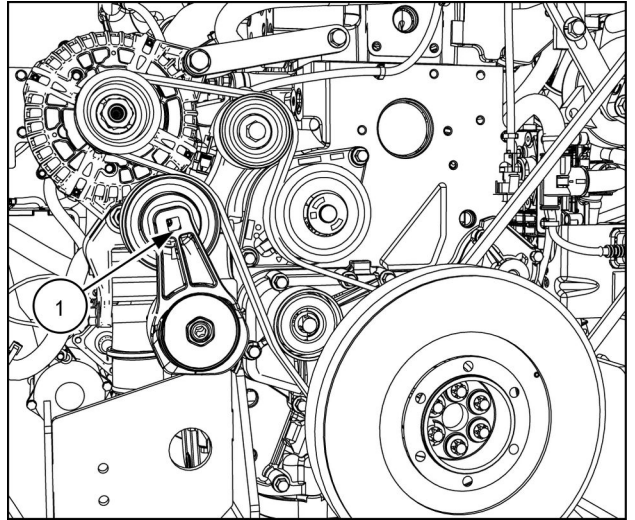

NHIL14AF00382AA 3

Engine - Install engine serpentine belt

AXIAL-FLOW® 5140 PIN YFG014001 - [YFG014001 -]

ANZ --- APAC --- MEA

Prior operation:

Engine - Remove engine serpentine belt (10.001)

1. Use a **0.5 in** ratchet wrench on the belt tensioner (**1**) to relieve the tension to install the serpentine belt to the engine pulleys. Route the belt as shown.

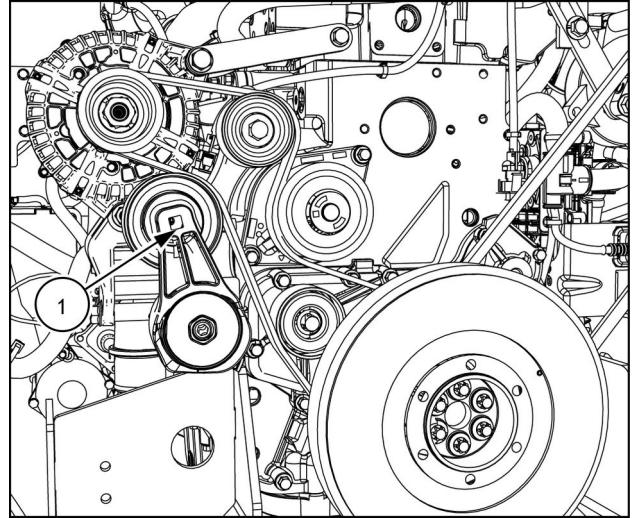

NHIL14AF00382AA 1

2. Install the fan access panel (**1**) to the engine compartment.

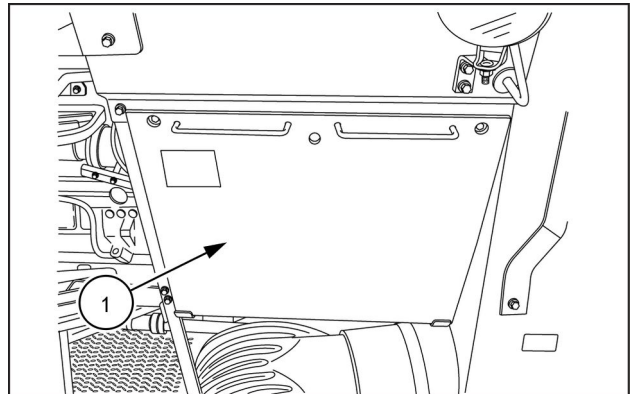

NH12AF00292A 2

3. Close the engine and rotor drive access doors.

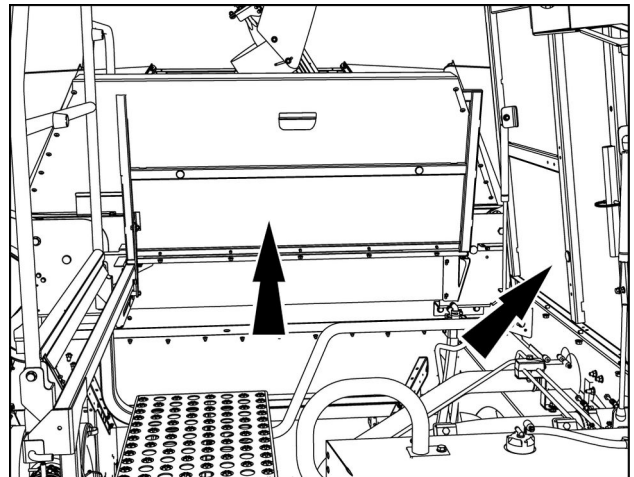

NHIL14AF00372AA 3

Engine - Remove engine serpentine belt

AXIAL-FLOW® 6140 PIN YFG014001- [YFG014001 -]	APAC
AXIAL-FLOW® 6140 YFG014001- [YFG014001 -]	ANZ --- APAC --- MEA
AXIAL-FLOW® 7140 PIN YFG014001 and above. [YFG014001 -]	APAC
AXIAL-FLOW® 7140 PIN YFG014001- [YFG014001 -]	ANZ --- APAC --- MEA

⚠ WARNING

Avoid injury! Always do the following before lubricating, maintaining, or servicing the machine.

- 1. Disengage all drives.**
- 2. Engage parking brake.**
- 3. Lower all attachments to the ground, or raise and engage all safety locks.**
- 4. Shut off engine.**
- 5. Remove key from key switch.**
- 6. Switch off battery key, if installed.**
- 7. Wait for all machine movement to stop.**

Failure to comply could result in death or serious injury.

W0047A

1. Open the engine and rotor drive access doors.

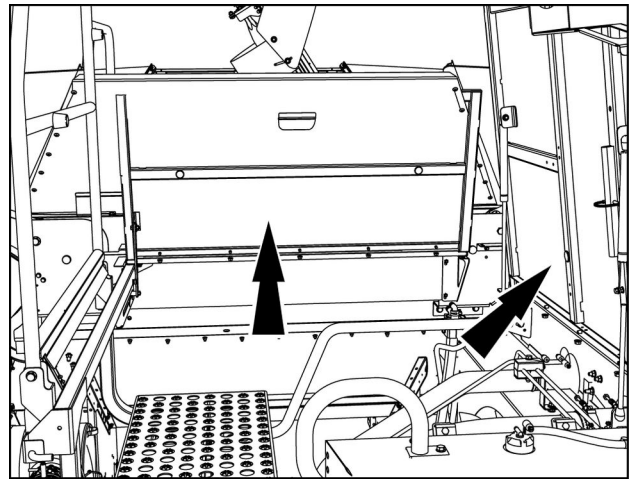

NHIL14AF00372AA 1

2. Remove the fan access panel (1) from the engine compartment.

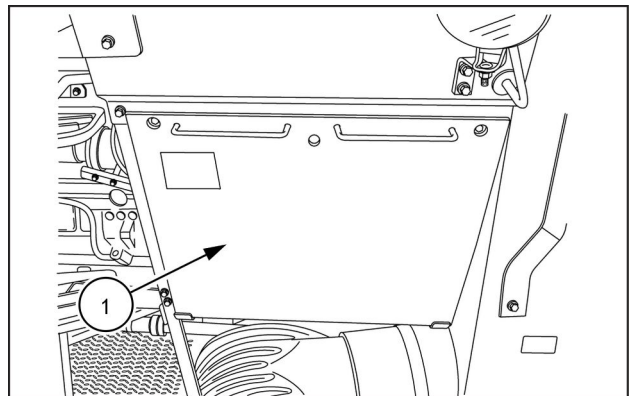

NH12AF00292A 2

3. Use a **0.5 in** ratchet wrench on the belt tensioner (**1**) to relieve the tension on the serpentine belt and remove it from the engine.

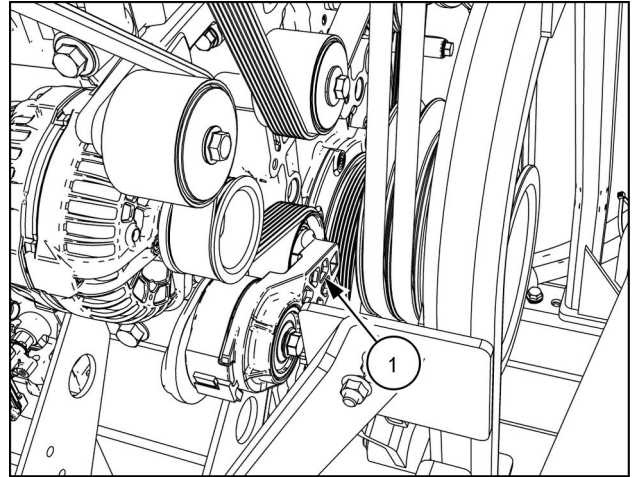

NHIL14AF00374AA 3

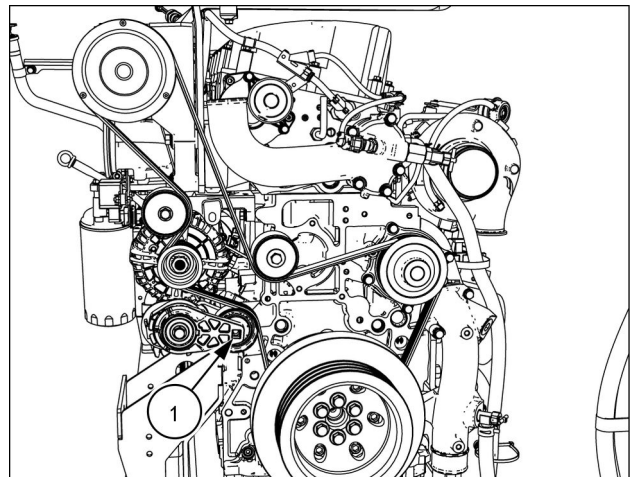

NHIL14AF00373AA 4

Engine - Install engine serpentine belt

AXIAL-FLOW® 6140 PIN YFG014001- [YFG014001 -]	APAC
AXIAL-FLOW® 6140 YFG014001- [YFG014001 -]	ANZ --- APAC --- MEA
AXIAL-FLOW® 7140 PIN YFG014001 and above. [YFG014001 -]	APAC
AXIAL-FLOW® 7140 PIN YFG014001- [YFG014001 -]	ANZ --- APAC --- MEA

Prior operation:

Engine - Remove engine serpentine belt (10.001)

1. Use a **0.5 in** ratchet wrench on the belt tensioner (**1**) to relieve the tension to install the serpentine belt to the engine pulleys. Route the belt as shown.

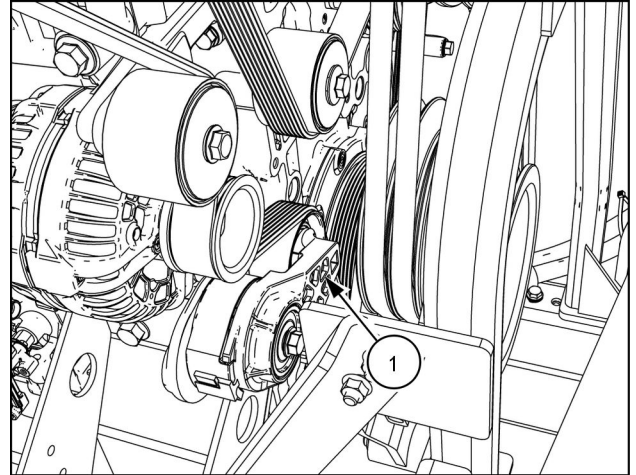

NHIL14AF00374AA 1

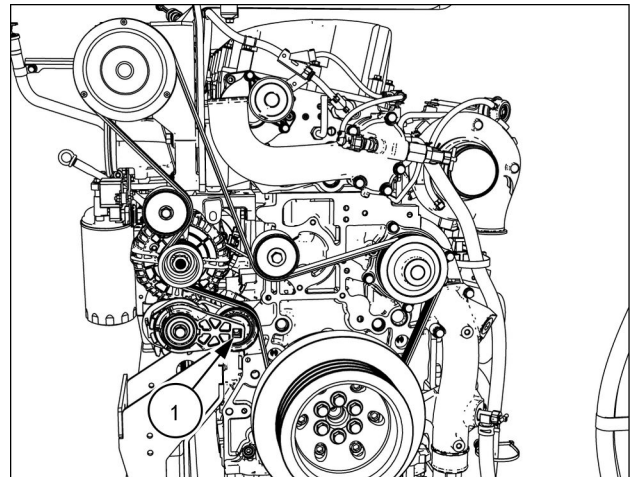

NHIL14AF00373AA 2

2. Install the fan access panel (**1**) to the engine compartment.

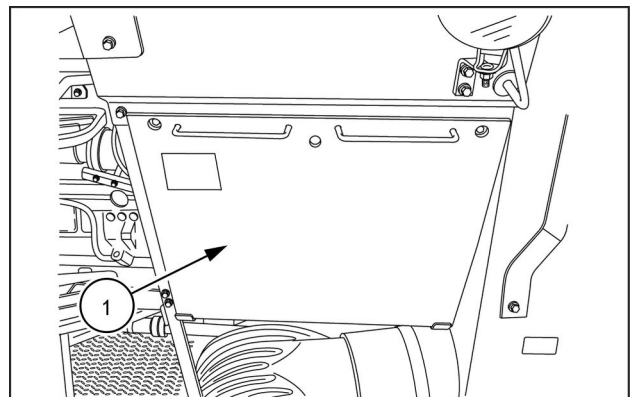

NH12AF00292A 3



Suggest:

If the above button click is invalid.

Please download this document

first, and then click the above link

to download the complete manual.

Thank you so much for reading

3. Close the engine and rotor drive access doors.

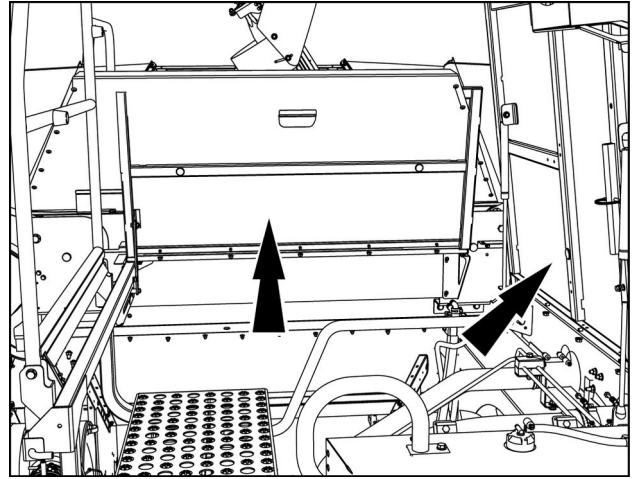

NHIL14AF00372AA 4

<https://www.ebooklibonline.com>

Hello dear friend!

Thank you very much for reading.

Enter the link into your browser.

The full manual is available for immediate download.

<https://www.ebooklibonline.com>