

# **CX250D** Crawler Excavator

## **SERVICE MANUAL**

Part number 47928442

English

September 2015

© 2015 CNH Industrial Italia S.p.A. All Rights Reserved.

**CASE**  
CONSTRUCTION



## **SERVICE MANUAL**

**CX250D Crawler excavators LC version (TIER4 FINAL) - EU Market**  
**CX250D Crawler excavators NLC version (TIER4 FINAL) - EU Market**

# Contents

---

## INTRODUCTION

Engine.....	10
[10.001] Engine and crankcase .....	10.1
[10.102] Pan and covers .....	10.2
[10.106] Valve drive and gears .....	10.3
[10.101] Cylinder heads .....	10.4
[10.105] Connecting rods and pistons.....	10.5
[10.103] Crankshaft and flywheel.....	10.6
[10.216] Fuel tanks .....	10.7
[10.206] Fuel filters .....	10.8
[10.218] Fuel injection system.....	10.9
[10.202] Air cleaners and lines .....	10.10
[10.250] Turbocharger and lines.....	10.11
[10.254] Intake and exhaust manifolds and muffler .....	10.12
[10.500] Selective Catalytic Reduction (SCR) exhaust treatment.....	10.13
[10.501] Exhaust Gas Recirculation (EGR) exhaust treatment.....	10.14
[10.400] Engine cooling system .....	10.15
[10.414] Fan and drive .....	10.16
[10.310] Aftercooler.....	10.17
[10.304] Engine lubrication system.....	10.18
Hydraulic systems.....	35
[35.000] Hydraulic systems.....	35.1
[35.300] Reservoir, cooler, and filters.....	35.2
[35.106] Variable displacement pump .....	35.3
[35.102] Pump control valves.....	35.4
[35.359] Main control valve.....	35.5
[35.357] Pilot system .....	35.6

**<https://www.ebooklibonline.com>**

Hello dear friend!

Thank you very much for reading.

Enter the link into your browser.

The full manual is available for immediate download.

**<https://www.ebooklibonline.com>**

[35.355] Hydraulic hand control .....	35.7
[35.356] Hydraulic foot control.....	35.8
[35.352] Hydraulic swing system .....	35.9
[35.353] Hydraulic travel system .....	35.10
[35.354] Hydraulic central joint .....	35.11
[35.736] Boom hydraulic system .....	35.12
[35.737] Dipper hydraulic system.....	35.13
[35.738] Excavator and backhoe bucket hydraulic system.....	35.14
[35.360] Hammer and rotating bucket hydraulic system .....	35.15
<b>Frames and ballasting .....</b>	<b>39</b>
[39.140] Ballasts and supports .....	39.1
<b>Tracks and track suspension .....</b>	<b>48</b>
[48.130] Track frame and driving wheels.....	48.1
[48.100] Tracks .....	48.2
[48.134] Track tension units .....	48.3
[48.138] Track rollers .....	48.4
<b>Cab climate control .....</b>	<b>50</b>
[50.100] Heating .....	50.1
[50.200] Air conditioning.....	50.2
<b>Electrical systems .....</b>	<b>55</b>
[55.000] Electrical system .....	55.1
[55.100] Harnesses and connectors.....	55.2
[55.525] Cab engine controls.....	55.3
[55.015] Engine control system.....	55.4
[55.201] Engine starting system .....	55.5
[55.301] Alternator.....	55.6
[55.302] Battery.....	55.7
[55.202] Cold start aid .....	55.8

[55.011] Fuel tank system .....	55.9
[55.010] Fuel injection system .....	55.10
[55.014] Engine intake and exhaust system.....	55.11
[55.988] Selective Catalytic Reduction (SCR) electrical system .....	55.12
[55.989] Exhaust Gas Recirculation (EGR) electrical system .....	55.13
[55.012] Engine cooling system .....	55.14
[55.013] Engine oil system .....	55.15
[55.640] Electronic modules .....	55.16
[55.512] Cab controls.....	55.17
[55.036] Hydraulic system control .....	55.18
[55.051] Cab Heating, Ventilation, and Air-Conditioning (HVAC) controls.....	55.19
[55.050] Heating, Ventilation, and Air-Conditioning (HVAC) control system.....	55.20
[55.524] Cab controls (Lift arm, Boom, Dipper, Bucket).....	55.21
[55.416] Swing control system .....	55.22
[55.417] Travel control system .....	55.23
[55.530] Camera.....	55.24
[55.518] Wiper and washer system.....	55.25
[55.404] External lighting .....	55.26
[55.514] Cab lighting .....	55.27
[55.408] Warning indicators, alarms, and instruments .....	55.28
[55.992] Anti-theft system .....	55.29
[55.DTC] FAULT CODES.....	55.30
<b>Booms, dippers, and buckets .....</b>	<b>84</b>
[84.910] Boom .....	84.1
[84.912] Dipper arm .....	84.2
[84.100] Bucket.....	84.3
<b>Platform, cab, bodywork, and decals .....</b>	<b>90</b>
[90.150] Cab.....	90.1

[90.156] Cab glazing .....	90.2
[90.118] Protections and footboards.....	90.3
[90.114] Operator protections .....	90.4
[90.120] Mechanically-adjusted operator seat.....	90.5
[90.100] Engine hood and panels .....	90.6
[90.116] Fenders and guards.....	90.7



## INTRODUCTION

---

## **Foreword - Important notice regarding equipment servicing**

All repair and maintenance work listed in this manual must be carried out only by qualified dealership personnel, strictly complying with the instructions given, and using, whenever possible, the special tools.

Anyone who performs repair and maintenance operations without complying with the procedures provided herein shall be responsible for any subsequent damages.

The manufacturer and all the organizations of its distribution chain, including - without limitation - national, regional, or local dealers, reject any responsibility for damages caused by parts and/or components not approved by the manufacturer, including those used for the servicing or repair of the product manufactured or marketed by the manufacturer. In any case, no warranty is given or attributed on the product manufactured or marketed by the manufacturer in case of damages caused by parts and/or components not approved by the manufacturer.

The manufacturer reserves the right to make improvements in design and changes in specifications at any time without notice and without incurring any obligation to install them on units previously sold. Specifications, descriptions, and illustrative material herein are as accurate as known at time of publication but are subject to change without notice.

In case of questions, refer to your CASE CONSTRUCTION Sales and Service Networks.

## Safety rules

### Personal safety



This is the safety alert symbol. It is used to alert you to potential personal injury hazards. Obey all safety messages that follow this symbol to avoid possible death or injury.

Throughout this manual you will find the signal words DANGER, WARNING, and CAUTION followed by special instructions. These precautions are intended for the personal safety of you and those working with you.

Read and understand all the safety messages in this manual before you operate or service the machine.

 DANGER indicates a hazardous situation that, if not avoided, will result in death or serious injury.

 WARNING indicates a hazardous situation that, if not avoided, could result in death or serious injury.

 CAUTION indicates a hazardous situation that, if not avoided, could result in minor or moderate injury.

**FAILURE TO FOLLOW DANGER, WARNING, AND CAUTION MESSAGES COULD RESULT IN DEATH OR SERIOUS INJURY.**

### Machine safety

**NOTICE:** Notice indicates a situation that, if not avoided, could result in machine or property damage.

Throughout this manual you will find the signal word Notice followed by special instructions to prevent machine or property damage. The word Notice is used to address practices not related to personal safety.

### Information

**NOTE:** Note indicates additional information that clarifies steps, procedures, or other information in this manual.

Throughout this manual you will find the word Note followed by additional information about a step, procedure, or other information in the manual. The word Note is not intended to address personal safety or property damage.

## **Safety rules – General information**

### **Cleaning**

Clean the metal parts with cleaning solution that meets the standard and steam cleaning. (except for bearings)

After cleaning, dry well, and inject oil in all parts.

Also inject oil into the bearings after drying.

### **Inspection**

When disassembling parts, check all the parts.

If there are any worn or damaged parts, replace them.

Inspect carefully to prevent initial breakdowns.

### **Bearing**

Replace any loose bearings.

Air dry bearings before installing them.

### **Needle bearing**

When inserting needle bearings, be very careful not to damage them.

Apply grease to the section where the needle bearing will be inserted.

### **Gear**

Check that there is no wear and no damage.

### **Oil seal, O-ring, gasket**

Always install new oil seals, O-rings, and gaskets.

Apply grease to sections where oil seals and O-rings will be inserted.

### **Shaft**

Check that there is no wear and no damage.

Check the bearings and check for damaged oil seals on the shaft.

### **Service parts**

Install CASE CONSTRUCTION genuine service parts.

When placing an order, check the parts catalog. It contains the CASE CONSTRUCTION genuine part numbers.

Any breakdowns arising from the installation of non-genuine parts are not covered by the warranty.

### **Lubricants (fuel, hydraulic oil)**

Use the oil from the specified company or specified in the operator's manual or service Manual.

Any breakdowns arising from any fuel or hydraulic oil other than those specified are not covered by the warranty.



## **SERVICE MANUAL**

### **Engine**

**CX250D Crawler excavators LC version (TIER4 FINAL) - EU Market**  
**CX250D Crawler excavators NLC version (TIER4 FINAL) - EU Market**

## Engine - General specification

### Engine main specifications

Item		Engine model 4HK1
Type		Diesel/4-cycle/water-cooled, inline 4 cylinder OHC
Shape of combustion chamber		Direct injection type
Cylinder liner type		Dry type
Cylinder bore x stroke		<b>115 mm (4.53 in) x 125 mm (4.92 in)</b>
Displacement		<b>5.193 L (317 in<sup>3</sup>)</b>
Compression ratio		16.5
Compression pressure		<b>3.23 MPa (469 psi) 200 RPM</b>
Idling speed		<b>800 RPM</b>
Valve clearance	Intake	<b>0.4 mm (0.016 in)</b> While cool
	Exhaust	<b>0.4 mm (0.016 in)</b> While cool
Ignition method		Compression ignition
Injection order		1, 3, 4, 2
Lubrication system		
Lubrication type		Compression type
Oil pump type		Gear type
Lubrication oil amount		<b>19.5 - 27 L (5.2 - 7.1 US gal)</b>
Oil filter type		Full-flow/partial flow integrated filter (Cartridge type)
Oil cooling type		Built-in type, water cooling
Cooling system		
Cooling type		Water cooling
Radiator type		Corrugated fin (Pressure type)
Water pump type		Centrifugal type, belt type
Thermostat type		2-wax type unit
Thermostat valve open valve temperature	Type 1	<b>76.5 °C (170 °F)</b> With jiggle valve
		<b>82 °C (180 °F)</b> Without jiggle valve
	Type 2	<b>85 °C (185 °F)</b> With jiggle valve
		<b>82 °C (180 °F)</b> Without jiggle valve
Coolant capacity		<b>14.5 L (3.8 US gal)</b>
Fuel system		
Injection pump type		Electronic control common rail (fuel rail) type
Governor type		Electronic type
Timer type		Electronic type
Injection nozzle type		Multi-hole type 7 holes, inner diameter Ø <b>0.14 mm (0.0055 in)</b>
Charging system		
Generator type		AC type
Output		<b>24 V 50 A</b>
Regulator type		IC
Starter system		
Starter type		Reduction type
Output		<b>24 V 5.0 kW</b>
Preheat system type		Glow plug
Glow plug standard voltage/current		<b>23 V 3.5 A</b>

### Cooling system main specifications

Item		Specifications
Water pump		Centrifugal impeller method
Pulley ratio		0.85
Thermostat		Wax pellet type
Full open temperature	Type 1	90 °C (194 °F) With jiggle valve
		95 °C (203 °F) Without jiggle valve
	Type 2	100 °C (212 °F) With jiggle valve
		95 °C (203 °F) Without jiggle valve

### Electrical system main specifications

Generator	
Item	Data
Isuzu parts number	8980921161
Nominal output	24 V/ 50 A
Rated speed	5000 RPM
Regulator type	IC type
Regulated voltage	27.5 - 29.5 V
Weight	9.5 kg (20.9 lb)

Starter		
Type (Manufacturer)	Nikko	
Rated	Voltage	24 V
	Output	5 kW (6.8 Hp)
	Time	30 s
No. of pinion gears	13	
Direction of rotation (toward pinion)	Clockwise	
Weight (approx.)	8.0 kg (17.6 lb)	
No-load characteristics	Current/voltage	85 A or less/ 24 V
	Speed	3300 RPM or more
Load characteristics	Current/voltage	400 A/ 18.5 V
	Torque	28.4 N·m (20.95 lb ft) or more
	Speed	1250 RPM or more
Locking characteristics	Current/voltage	1400 A or less/ 9 V
	Torque	88.2 N·m (65.05 lb ft) or more

## Engine - Identification

### Engine number

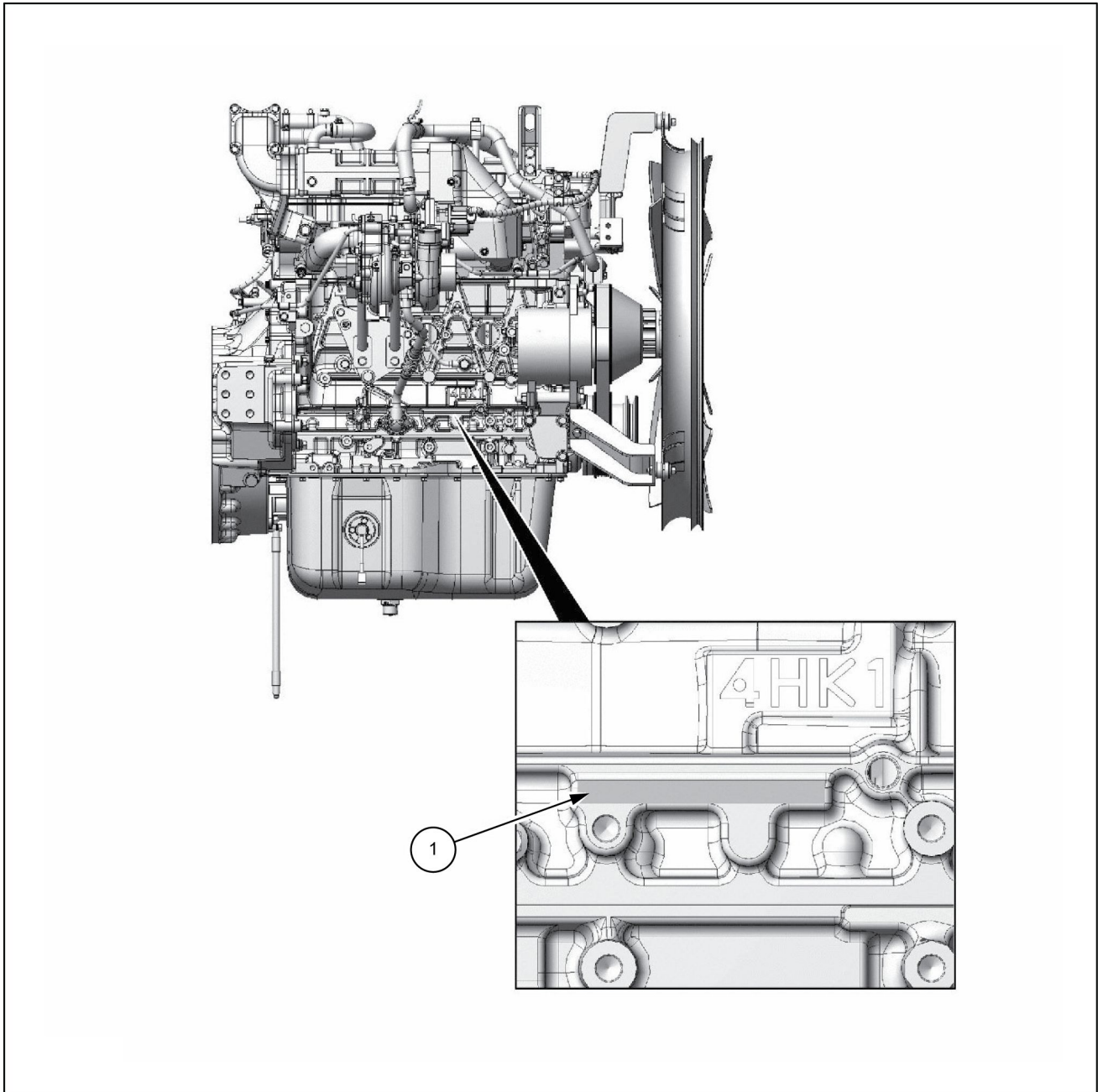

SML13CEX1711GB 1

1. Engine number stamping

## **Engine - Static description**

The control provided by the control unit applies to the range from injection to air intake and exhaust, including fuel injection quantity, injection timing, air intake restriction, EGR, and idling speed.

### **Cylinder block**

The cylinder block is made of cast iron, and it has an equal center distance for each bore and a high rigidity, and the center of the crankshaft matches the center of the block. Tighten the bearing cap using the plastic region rotational angle tightening method with the ladder frame structure.

### **Cylinder liner**

A cylinder liner that matches with the cylinder block bore inner diameter is selected, and the identification number is stamped on the left side of the cylinder.

### **Piston**

The piston is a strut cast autothermatic piston made of aluminum alloy, and the combustion chamber is the round re-entrant type.

### **Cylinder head**

The cylinder head is made of cast iron and has four valves per cylinder. The angle tightening method has been adopted for the cylinder head bolt to further improve its reliability and durability.

### **Crankshaft**

The crankshaft uses tufftrided steel, and each of the journal diameter grades are marked on the No. 1 balance weight.

### **EGR system**

The EGR system is controlled by the engine control module (ECM) according to various data, including the water temperature, engine speed, and engine load, to recirculate the exhaust gas for purification. The primary components are the EGR valve, EGR cooler, and various sensors.

### **Connecting rod cap bolt**

The angle tightening method has been adopted for the connecting rod cap bolt to further improve its reliability and durability.

### **Common rail (fuel rail) type electronic control injection system**

The common rail (fuel rail) type electronic control injection system consists of the fuel supply pump that sets the target pressure of the high pressure fuel to supply the fuel, the common rail (fuel rail) that measures the high-pressure fuel, and the fuel injector that injects the fuel in the form of a fine mist. Each of these is controlled by the ECM based on various signals that control the injection timing and injection quantity in accordance with driving conditions.

### **Fuel injector**

The fuel injector has adopted the 7- hole nozzle, and adjusts the fuel injection quantity and injection timing by opening or closing the electromagnetic valve on the injector head portion.

The ECM corrects variations in the fuel injection quantity between fuel injectors in accordance with the ID code data in the memory. When adjusting the fuel injector, the ID code data must be recorded in the ECM.

### **Fuel filter with sedimenter**

The fuel filter with sedimenter removes water by using the difference in the specific gravity of diesel oil and water, and notifies the operator through the indicator when it becomes full of water.

### **Preheat system**

The preheat system consists of the ECM, glow relay, glow plug, and glow indicator light. The preheat system is activated when the engine coolant temperature is low so as to help the engine start.

### **Lubricating system**

An oil filter with a full-flow bypass is used, and the pistons are cooled down using the water-cooled oil cooler and the oil jet.

## Engine - Prepare

### **⚠ WARNING**

#### **Escaping fluid!**

Hydraulic fluid or diesel fuel leaking under pressure can penetrate the skin and cause infection or other injury. To prevent personal injury: Relieve all pressure before disconnecting fluid lines or performing work on the hydraulic system. Before applying pressure, make sure all connections are tight and all components are in good condition. Never use your hand to check for suspected leaks under pressure. Use a piece of cardboard or wood for this purpose. If injured by leaking fluid, see your doctor immediately.

Failure to comply could result in death or serious injury.

W0178A

### **⚠ WARNING**

#### **Avoid injury!**

Shut off the engine, remove the key, and make sure all motion is stopped before servicing the machine.

Failure to comply could result in death or serious injury.

W1128A

### **⚠ WARNING**

#### **Crushing hazard!**

The lifting systems must be operated by qualified personnel who are aware of the correct procedures to follow. Make sure all lifting equipment is in good condition, and all hooks are equipped with safety latches.

Failure to comply could result in death or serious injury.

W0256A

### **⚠ WARNING**

#### **Heavy objects!**

Lift and handle all heavy components using lifting equipment with adequate capacity. Always support units or parts with suitable slings or hooks. Make sure the work area is clear of all bystanders.

Failure to comply could result in death or serious injury.

W0398A

### **⚠ WARNING**

#### **Explosion hazard!**

Batteries emit explosive gases. Always ventilate when using in an enclosed area or when charging. Keep the battery away from sparks, open flames, and other ignition sources.

Failure to comply could result in death or serious injury.

W0369A

**NOTICE:** *Keep away from flames.*

**NOTICE:** *The air conditioner circuit is filled with high pressure gas, gas may spray out dangerously when loosening lines.*

Items to prepare:

- Wrenches [ **7 mm, 8 mm, 9,5 mm, 10 mm, 13 mm, 14 mm, 17 mm, 36 mm** ]
- Box wrench [ **24 mm**]
- Shackle (with the required lifting capacity) x 2
- Wire rope (with the required breaking load)
- Lifting equipment (with the required lifting capacity)
- Marking pen
- Cap
- Plug
- Waste oil can
- Rag
- Cleaning fluid
- Wood plank, etc.

## Engine - Remove

1. Remove the counterweight. (For details, See "**Counterweight - Remove (39.140)** and **Counterweight - Install (39.140)**").
2. Remove the pump. (For details, See "**Pump - Remove (35.106)** and **Pump - Install (35.106)**").
3. Use a wrench [ **14 mm**] to remove the bolts (1) and (2), and then remove the fan shroud (3).

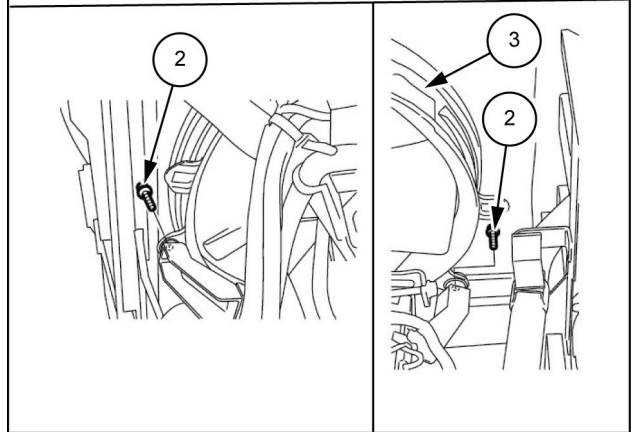
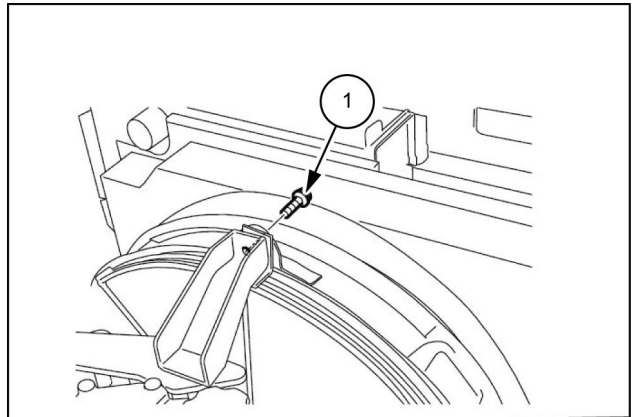

LPIL12CX00144BB 1

4. Use a wrench to remove the bolts (1), and then remove the fan guard (2).

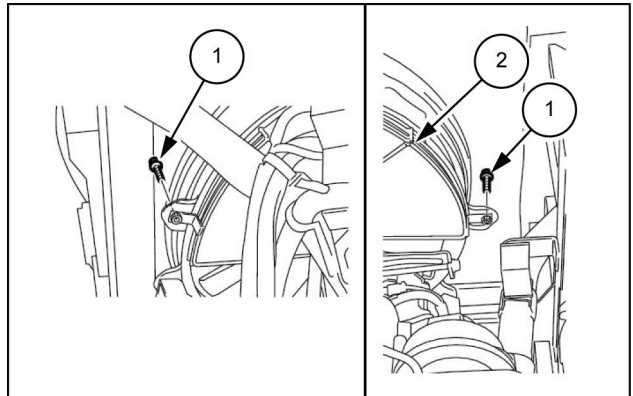

LPIL12CX00145AB 2

5. Use a wrench [ **7 mm**] to loosen the hose band (1) on the radiator, and then remove the upper hose (2).

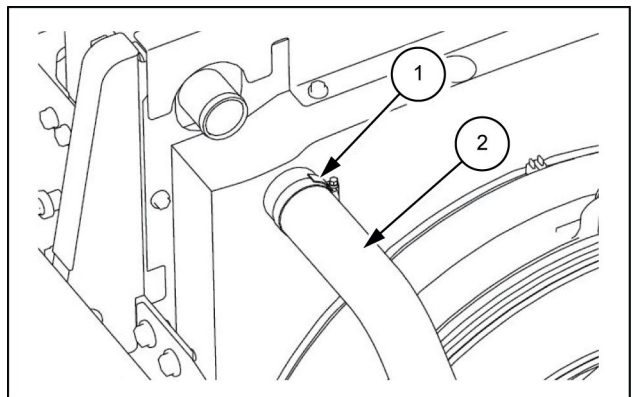

SMIL13CEX1230AB 3

6. Use a wrench [ **7 mm** ] to loosen the hose band (1) on the radiator, and then remove the lower hose (2).

- Attach caps at each location of the radiator and the hose so as to prevent invasion of water, dust, and dirt.
- Completely drain coolant before removing the radiator hose.

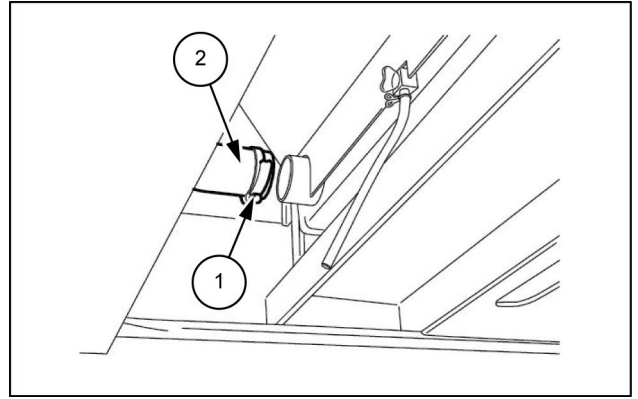

SMIL13CEX1231AB 4

7. Use a wrench [ **12 mm** ] to loosen the line bolts (1) in 2 locations, and then remove the pipings (2) and (3) from the compressor.

- Make sure to remove the piping (2) of low pressure (suction side) side first.
- Attach caps and plugs at each location of the compressor and piping in order to prevent invasion of water, dust and dirt.

3. Line (discharge side)

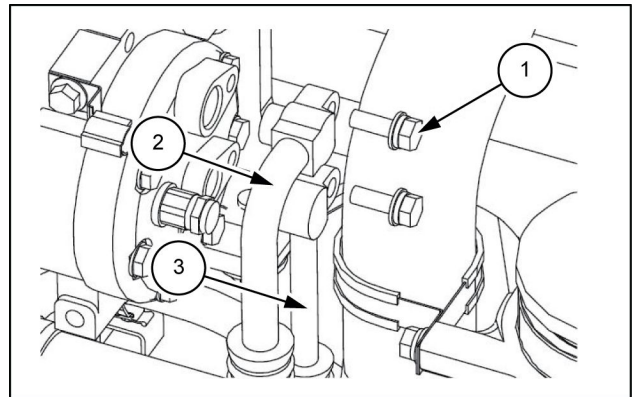

SMIL13CEX1232AB 5

8. Use a wrench [ **8 mm** ] to loosen the hose band (1) on the intercooler, and then remove the hose (2).

- Attach caps at each location of the piping and the hose so as to prevent invasion of water, dust and dirt.

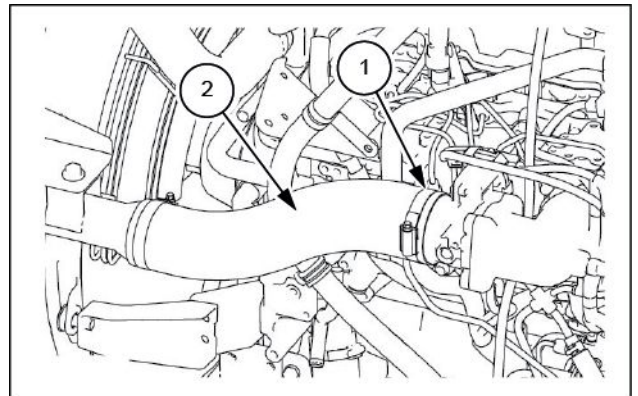

SMIL13CEX1233AB 6

9. Prepare a waste oil can (1).

- Drain the engine oil before removing the engine oil hose.

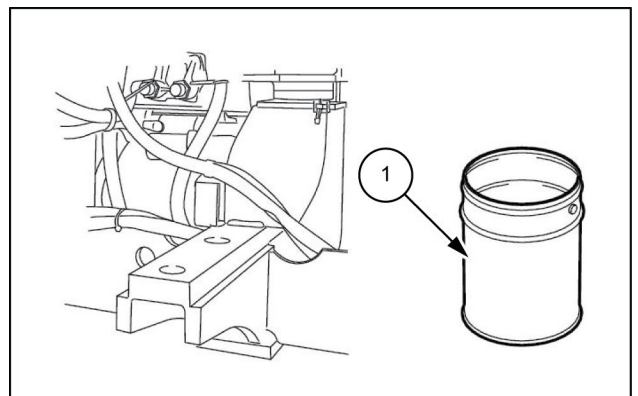

SMIL13CEX1235AB 7

10. Use a wrench [ **36 mm** ] to remove the 2 engine oil remote hoses (1).

- Apply marking at each location of the engine and the hoses so as to match connections at assembling.
- Attach caps and plugs at each location of the engine and the hoses so as to prevent invasion of water, dust and dirt.
- Wash each location of the engine and the hoses by blowing parts cleaner so as to prevent adhering dirt at connections and not to damage them.

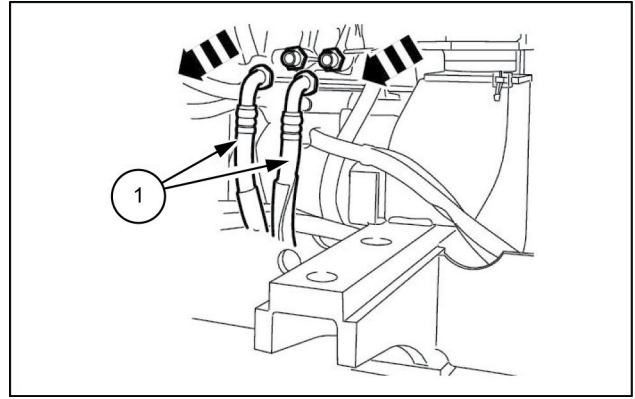

SMIL13CEX1236AB 8

11. Remove the nut (1) with a wrench [ **13 mm** ] to remove the battery cable (2) for minus side.

- Secure the terminal and harness in order to prevent them from touching the frame or other parts when they have been removed. Or protect them with a rubber cap or other cap to prevent sparks.

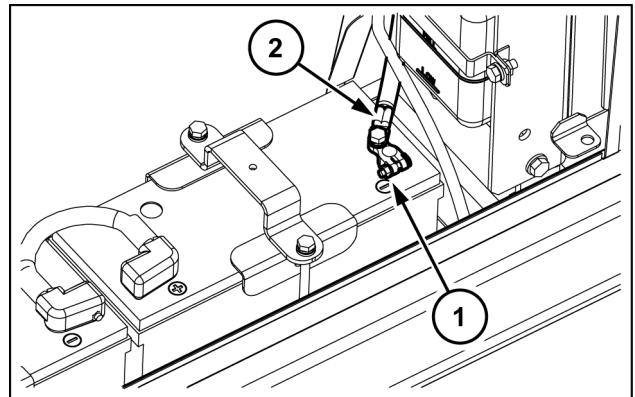

SMIL14CEX5664AB 9

12. Use a wrench [ **8 mm** ] to remove the nut (1), and then disconnect the wiring (2) from the starter motor.

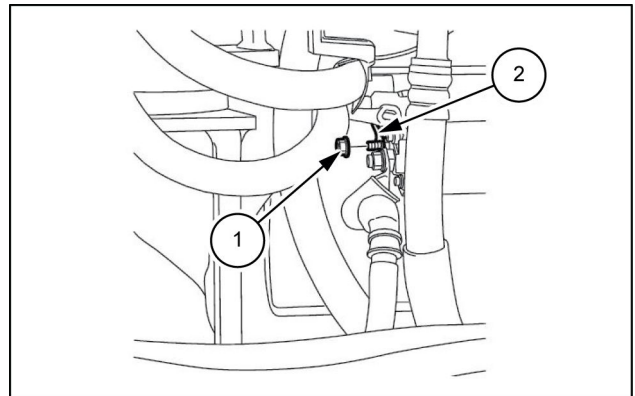

SMIL13CEX1238AB 10

13. Use a wrench [ **14 mm** ] to remove the nut (1), and then disconnect the wiring (2) from the starter motor.

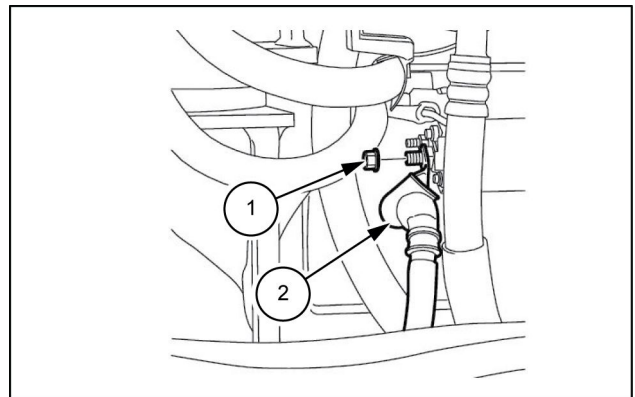

SMIL13CEX1239AB 11

14. Remove the hose band (1), and then remove the fuel hose (2).

- Attach caps and plugs at the engine and the hoses so as to prevent invasion of water, dust and dirt.

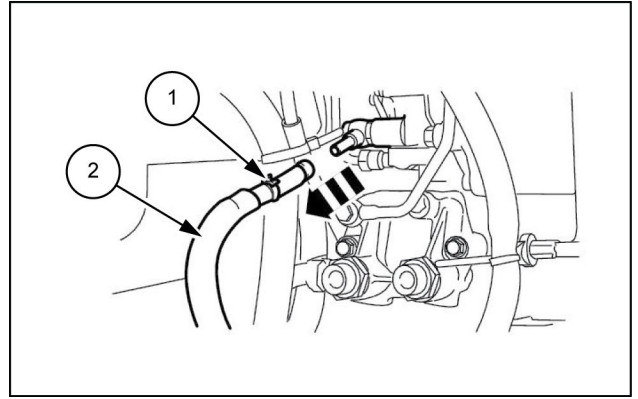

SMIL13CEX1240AB 12

15. Remove the hose band (1), and then remove the fuel hose (2).

- Attach caps and plugs at the engine and the hoses so as to prevent invasion of water, dust and dirt.

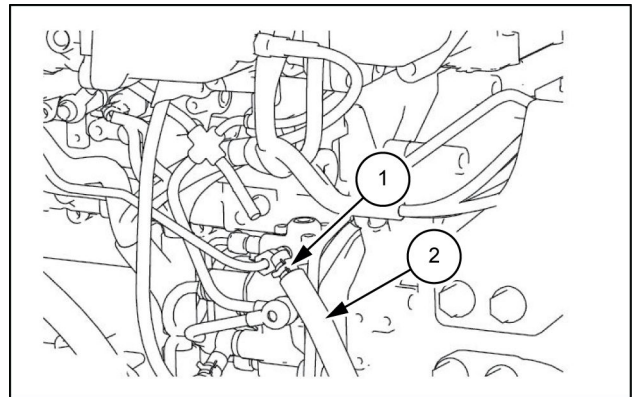

SMIL13CEX1241AB 13

16. Use a wrench [ 13 mm] to remove the 2 bolts (1), and then remove the connector bracket (2).

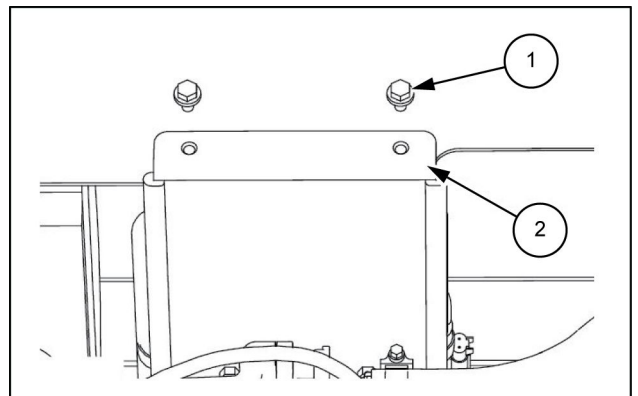

SMIL13CEX1242AB 14

17. Use a wrench [ 13 mm] to remove the hose band (1) from the bracket, and then remove the connectors (2).

- Wrap the disconnected connectors with a plastic sheet after bundle them.

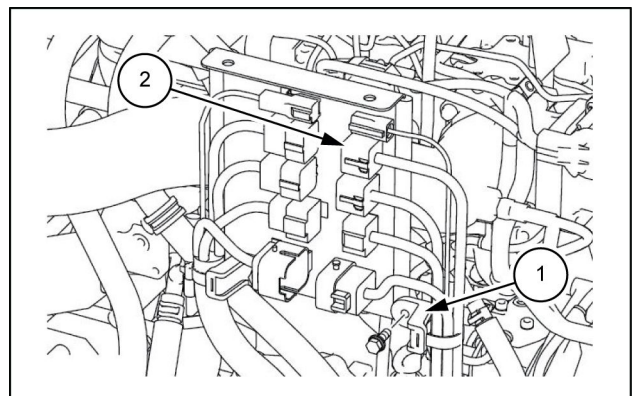

SMIL13CEX1243AB 15

18. Loosen the hose band to disconnect the three heater hoses (1).  
Loosen the hose band to disconnect the fuel hose (2).
- Attach caps and plugs at the engine and the hoses so as to prevent invasion of water, dust and dirt.

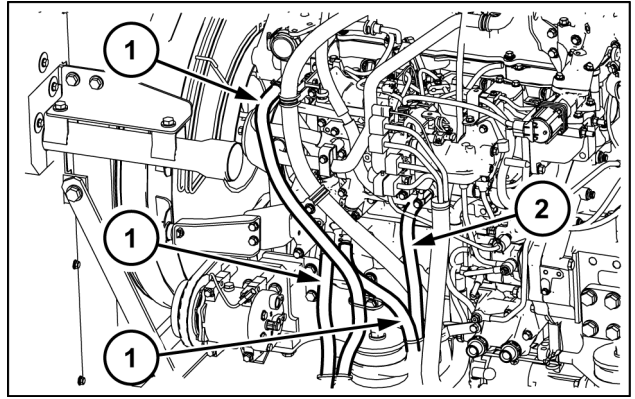

SMIL14CEX5665AB 16

19. Use a wrench [ **9.5 mm** ] to loosen the hose band (1), and then remove the air hose (2).
- Attach caps at the piping and the hose so as to prevent invasion of water, dust and dirt.

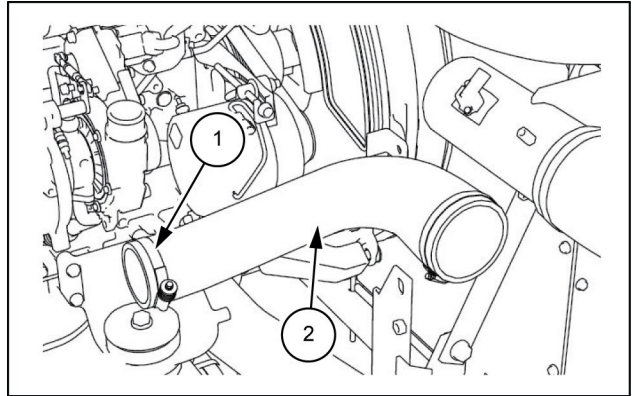

SMIL13CEX1248AB 17

20. Remove the connectors (1) from the alternator.



SMIL13CEX1249AB 18

21. Use a wrench [ **10 mm** ] to remove the nut (1), and then remove the wiring (2) from the alternator.

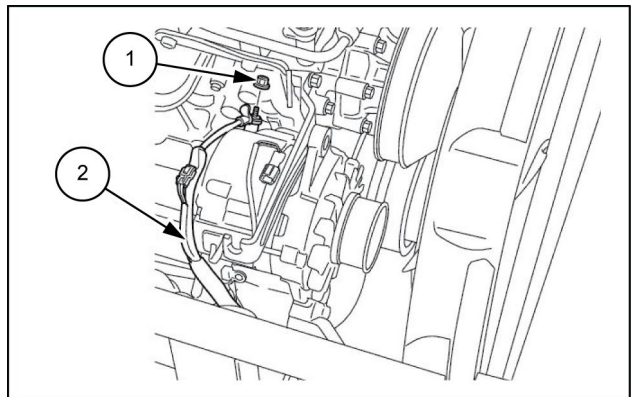

SMIL13CEX1250AB 19

22. Remove the six nuts **(1)** with a wrench [ 13 mm] to remove the muffler **(2)**.

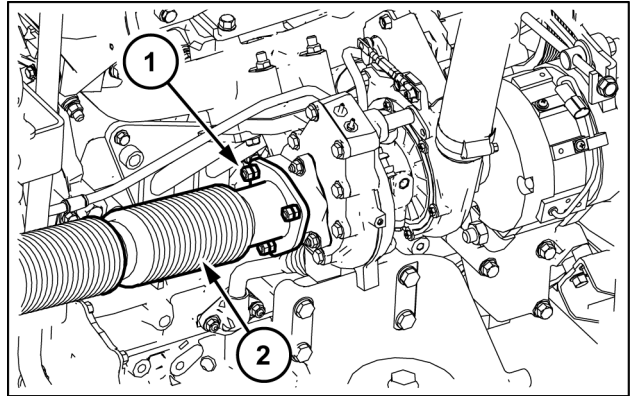

SMIL14CEX5666AB 20

23. Attach the two shackles **(1)** and then secure the engine main unit with a wire rope **(2)** and a lifting equipment.

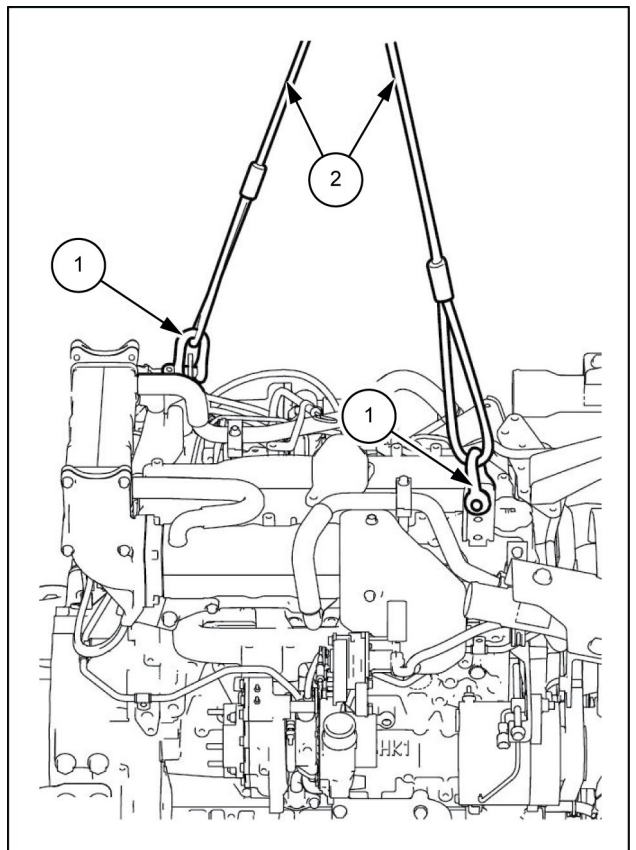

SMIL13CEX1252BB 21

24. Use a box wrench [ **24 mm** ] to remove the 4 bolts ( **1** ) from the mount.

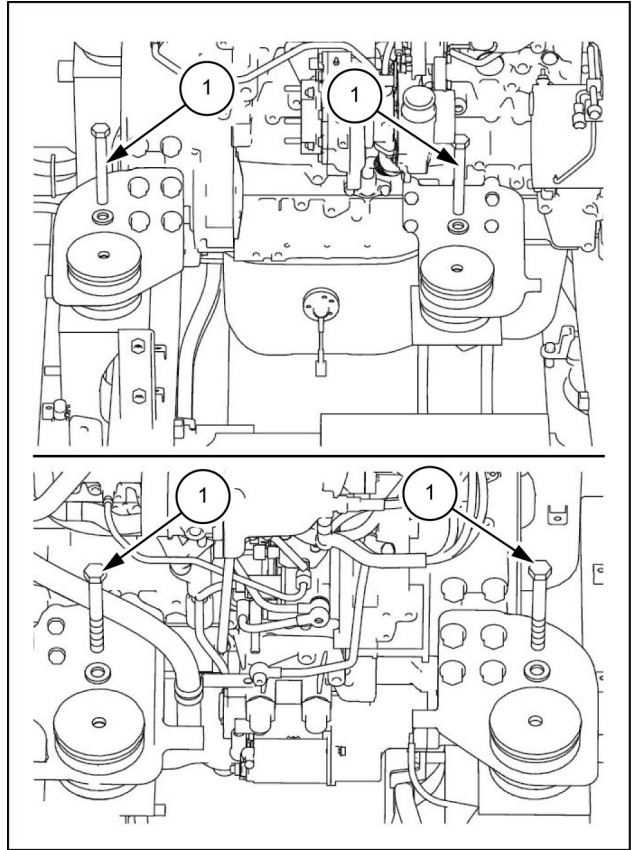

SMIL13CEX1253BB 22

25. Lift the engine main unit with a wire rope ( **1** ) and a lifting equipment. Make sure that you have a safe site, and then settle the engine on a wood plank or other block.

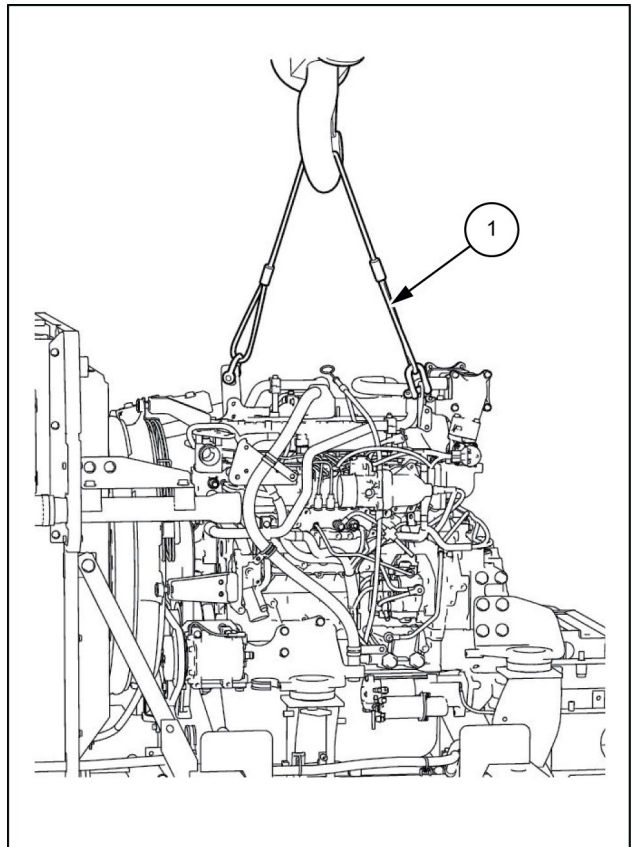

SMIL13CEX1254BB 23

## Engine - Install

1. To install the engine, perform the reverse of the removal procedure.  
After installing the engine, resupply coolant and engine oil, perform fuel line air bleeding, and perform filling for the air-conditioner gas.  
For details, see the individual explanations for each procedure.
2. Run the engine at no-load idling and check for any water or oil leaks.
3. Attach the hydraulic pump, covers, and counterweight.  
For details, see the individual explanations for each procedure.

## Engine - Check - Engine oil

### **⚠ WARNING**

#### **Burn hazard!**

Do not handle any service fluid (engine coolant, engine oil, hydraulic oil, etc.) at temperatures that exceed 49 °C (120 °F). Allow fluids to cool before proceeding.  
Failure to comply could result in death or serious injury.

W0330B

**NOTICE:** The engine should be in a horizontal position.

**NOTICE:** Wait at least 5 min before starting the engine and after stopping the engine.

### Engine oil inspection

1. Remove the oil level gauge from the oil level gauge guide tube.

**NOTE:** Wipe off the engine oil remaining on the oil level gauge.

2. Install the oil level gauge to the oil level gauge guide tube.
3. Remove the oil level gauge from the oil level gauge guide tube.
4. Inspect the engine oil.

**NOTE:** Check the engine oil remaining on the oil level gauge to inspect the engine oil level.

1. Upper limit
2. Lower limit

**NOTE:** If the oil level is under the lower limit, add engine oil. Replace the engine oil if engine oil is dirty.

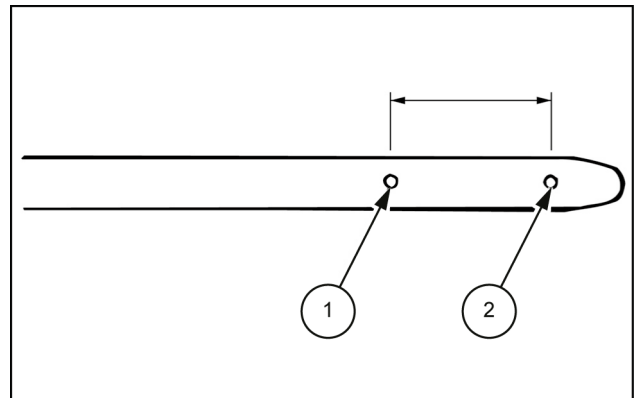

SMIL14CEX3221AB 1

## Engine - Test - Engine oil

### Sampling of engine oil

1. Open the side door (1).  
At this time, make sure to apply the lock (2).

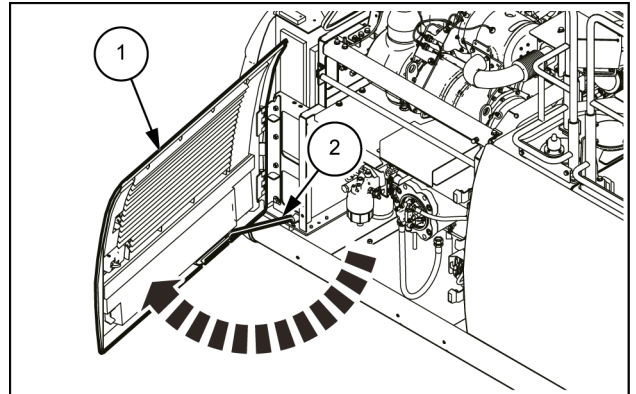

SMIL14CEX1174AB 1

2. Place a sampling container under the sampling port (1).
3. Open the valve (2) to drain a proper amount of oil.
4. Close the valve (2) to check that there is no leakage.
5. If necessary, add the same amount of oil as the drained oil.

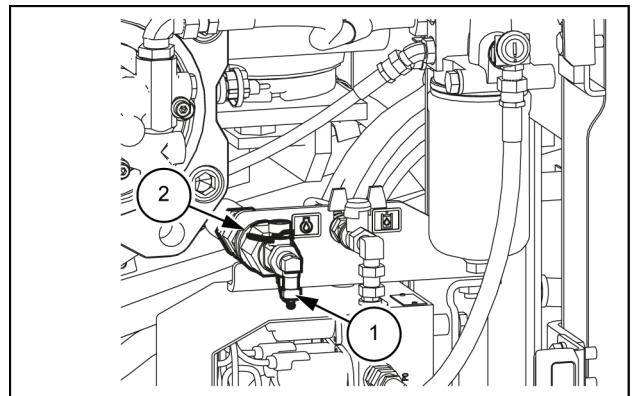

SMIL14CEX1175AB 2



**Suggest:**

**If the above button click is invalid.**

**Please download this document**

**first, and then click the above link**

**to download the complete manual.**

**Thank you so much for reading**

## Engine - Compression test

**NOTE:** Warm up the engine.

1. Remove the glow plug from the cylinder head assembly.

**NOTE:** Remove all the glow plugs.

2. Remove the injector harness connectors (1) from the lower cover.

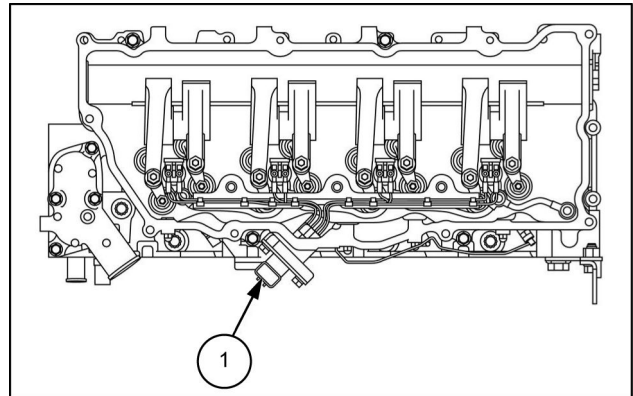

SMIL14CEX5667AB 1

3. Install the special tool on the cylinder head assembly.

Special tool: Compression gauge adapter (Refer to **Cylinder head - Special tools (10.101)**)

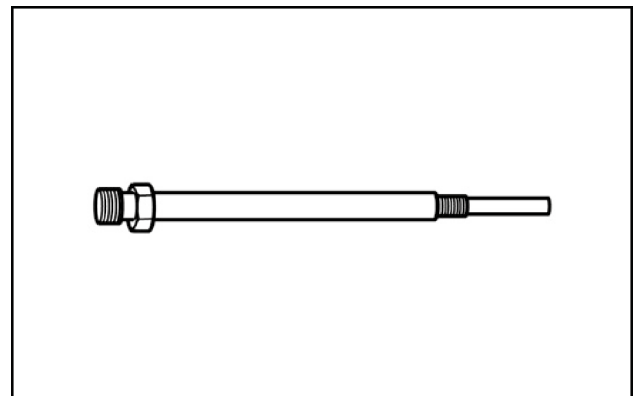

SMIL14CEX3445AA 2

Special tool: Compression gauge (adapter) (Refer to **Cylinder head - Special tools (10.101)**)

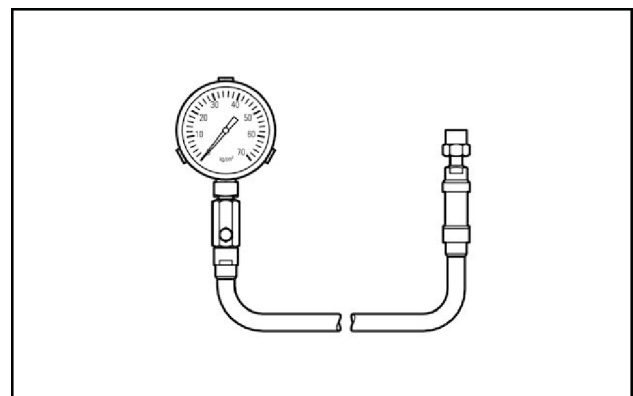

SMIL14CEX3446AA 3

**<https://www.ebooklibonline.com>**

Hello dear friend!

Thank you very much for reading.

Enter the link into your browser.

The full manual is available for immediate download.

**<https://www.ebooklibonline.com>**