

# CX130 Crawler Excavators

## Table of Contents

DIVISION/SECTION	SECTION N°	REFERENCE N°
<b>1 GENERAL INFORMATION</b>		
Safety, general information and standard torque data .....	1001	7-27690GB
General specifications and special torque setting.....	1002	7-27715GB
<b>2 ENGINE</b>		
Removal and installation of the engine .....	2000	7-28220GB
Radiator and oil-cooler .....	2001	7-28040GB
Engine specifications .....	*	
Disassembly and assembly of the engine.....	*	
<b>3 FUEL SYSTEM</b>		
Fuel tank .....	3001	7-27970GB
Fuel engine system.....	*	
<b>4 ELECTRICAL SYSTEM</b>		
Electrical system, electrical and electronic troubleshooting .....	4001	7-27724GB
Inspection and maintenance of batteries and connecting a booster battery ....	4002	7-27921GB
Main and engine electronic control boxes.....	4003	7-27933GB
<b>5 UNDERCARRIAGE</b>		
Removal and installation of tracks .....	5001	7-27750GB
Removal and installation of a set of rubber tracks .....	5002	7-27760GB
Rollers.....	5003	7-27772GB
Sprocket.....	5004	7-27781GB
Idler wheel and tension shock absorber .....	5005	7-27803GB
<b>6 DRIVE TRAIN</b>		
Drive motor and final drive transmission removal and installation .....	6001	7-27841GB
Drive motor and final drive transmission disassembly and assembly .....	6002	7-28750GB
Swing reduction gear, removal and installation.....	6003	7-27830GB
Swing reduction gear, disassembly and assembly .....	6004	7-28000GB
<b>7 UNDERCARRIAGE HYDRAULICS</b>		
<b>8 UPPERSTRUCTURE HYDRAULICS</b>		
Depressurising and decontaminating the hydraulic system, use of the vacuum pump and bleeding the components .....	8000	7-27952GB
Specifications, troubleshooting, checks and hydraulic pressure settings .....	8001	7-27704GB
Hydraulic reservoir removal and installation .....	8002	7-27990GB
Main and pilot pumps, removal and installation .....	8003	7-27871GB
Main hydraulic control valve, removal and installation.....	8004	7-27880GB
Attachment cylinders, removal and installation .....	8005	7-27791GB
Hydraulic swivel, removal and installation .....	8006	7-27811GB
Pilot blocs, removal and installation .....	8007	7-28100GB
Swing motor, removal and installation .....	8008	7-28060GB
Main hydraulic pump, disassembly and assembly .....	8010	7-29770GB
Main hydraulic control valve, disassembly and assembly.....	8011	7-28200GB
Attachment cylinders, disassembly and assembly.....	8012	7-27902GB
Hand control levers, disassembly and assembly .....	8013	7-28110GB
Foot control levers, disassembly and assembly .....	8014	7-28300GB
Six-solenoid valves, disassembly and assembly .....	8015	7-27911GB
Caution valve, disassembly and assembly .....	8016	7-27942GB
Safety valve .....	8017	7-29631GB
Hydraulic swivel, disassembly and assembly .....	8018	7-28080GB
Swing motor, disassembly and assembly .....	8019	7-28011GB
Hydraulic functions.....	8020	7-28481GB

DIVISION/SECTION	SECTION N°	REFERENCE N°
<b>9 UPPERSTRUCTURE</b>		
Quick coupler .....	9000	9-93630GB
Upperstructure, turntable and counterweight .....	9002	7-27982GB
Boom, dipper and bucket .....	9003	7-27963GB
Seat and seat belt .....	9004	7-28120GB
Cab and cab equipment .....	9005	7-28022GB
Air conditioning troubleshooting .....	9006	9-88730GB
Air conditioning unit disassembly and assembly .....	9007	██████████
Air conditioning servicing .....	9008	██████████
Air conditioning components .....	9009	██████████
Large format electrical schematic .....	Pocket	9-88430
Large format hydraulic schematic .....	Pocket	9-88380
Hydraulic schematic with dozer blade (Huchida pump) .....	Pocket	7-29592
Hydraulic schematic with dozer blade (Kawasaki pump) .....	Pocket	9-54670

\* *Consult the Engine Service Manual*

██████████ *Sections to be distributed at a later date*

NOTE: CNH Company reserves the right to make changes in the specification and design of the machine without prior notice and without incurring any obligation to modify units previously sold.

The description of the models shown in this manual has been made in accordance with the technical specifications known as of the date of design of this document.

# Section

# 1001

## SAFETY, GENERAL INFORMATION AND TORQUE SPECIFICATIONS

**<https://www.ebooklibonline.com>**

Hello dear friend!

Thank you very much for reading.

Enter the link into your browser.

The full manual is available for immediate download.

**<https://www.ebooklibonline.com>**

## TABLE OF CONTENTS

GENERAL INFORMATION .....	3
SAFETY .....	4
STANDARD TORQUE DATA FOR CAP SCREWS AND NUTS.....	6



**WARNING** : *This symbol is used in this manual to indicate important safety messages. Whenever you see this symbol, carefully read the message that follows, as there is a risk of serious injury.*

## GENERAL INFORMATION

### Cleaning

Clean all metal parts except bearings, in a suitable cleaning solvent or by steam cleaning. Do not use caustic soda for steam cleaning. After cleaning, dry and put oil on all parts. Clean oil passages with compressed air. Clean bearings in a suitable cleaning solvent, dry the bearings completely and put oil on the bearings.

### Inspection

Check all parts when the parts are disassembled. Replace all parts that have wear or damage. Small scoring or grooves can be removed with a hone or crocus cloth. Complete a visual inspection for indications of wear, pitting and the replacement of parts necessary to prevent early failures.

### Bearings

Check bearings for easy action. If bearings have a loose fit or rough action replace the bearing. Wash bearings with a suitable cleaning solvent and permit to air dry. **DO NOT DRY BEARINGS WITH COMPRESSED AIR.**

### Needle bearings

Before you press needle bearings in a bore always remove any metal protrusions in the bore or edge of the bore. Before you press bearings into position put petroleum jelly on the inside and outside diameter of the bearings.

### Gears

Check all gears for wear and damage. Replace gears that have wear or damage.

### Oil seals, O-rings and gaskets

Always install new oil seals, O-rings and gaskets. Put petroleum jelly on seals and O-rings.

### Shafts

Check all shafts that have wear or damage. Check the bearing and oil seal surfaces of the shafts for damage.

### Service parts

Always install genuine Case service parts. When ordering refer to the Parts Catalog for the correct part number of the genuine Case replacement items. Failures due to the use of other than genuine Case replacement parts are not covered by warranty.

### Lubrication

Only use the oils and lubricants specified in the Operator's or Service Manuals. Failures due to the use of non-specified oils and lubricants are not covered by warranty.

## SAFETY



*This symbol means ATTENTION! BECOME ALERT! YOUR SAFETY IS INVOLVED. The message that follows the symbol contains important information about safety. Carefully read the message. Make sure you fully understand the causes of possible injury or death.*

To prevent injury always follow the Warning, Caution and Danger notes in this section and throughout the manual.

Put the warning tag shown below on the key for the keyswitch when servicing or repairing the machine. One warning tag is supplied with each machine. Additional tags Part Number 331-4614 are available from your service parts supplier



**WARNING:** *Read the operator's manual to familiarize yourself with the correct control functions.*



**WARNING:** *Operate the machine and equipment controls from the seat position only. Any other method could result in serious injury.*



**WARNING:** *This is a one man machine, no riders allowed.*



**WARNING:** *Before starting engine, study Operator's Manual safety messages. Read all safety signs on machine. Clear the area of other persons. Learn and practice safe use of controls before operating.*

*It is your responsibility to understand and follow manufacturers instructions on machine operation, service and to observe pertinent laws and regulations. Operator's and Service Manuals may be obtained from your Case dealer.*



**WARNING:** *If you wear clothing that is too loose or do not use the correct safety equipment for your job, you can be injured. Always wear clothing that will not catch on objects. Extra safety equipment that can be required includes hard hat, safety shoes, ear protection, eye or face protection, heavy gloves and reflector clothing.*



**WARNING:** *When working in the area of the fan belt with the engine running, avoid loose clothing if possible, and use extreme caution.*



**WARNING:** *When doing checks and tests on the equipment hydraulics, follow the procedures as they are written. DO NOT change the procedure.*



**WARNING:** *When putting the hydraulic cylinders on this machine through the necessary cycles to check operation or to remove air from a circuit, make sure all people are out of the way.*



**WARNING:** Use insulated gloves or mittens when working with hot parts.



**WARNING:** Lower all attachments to the ground or use stands to safely support the attachments before you do any maintenance or service.



**WARNING:** Pin sized and smaller streams of hydraulic oil under pressure can penetrate the skin and result in serious infection. If hydraulic oil under pressure does penetrate the skin, seek medical treatment immediately. Maintain all hoses and tubes in good condition. Make sure all connections are tight. Make a replacement of any tube or hose that is damaged or thought to be damaged. DO NOT use your hand to check for leaks, use a piece of cardboard or wood.



**WARNING:** When removing hardened pins such as a pivot pin, or a hardened shaft, use a soft head (brass or bronze) hammer or use a driver made from brass or bronze and a steel head hammer.



**WARNING:** When using a hammer to remove and install pivot pins or separate parts using compressed air or using a grinder, wear eye protection that completely encloses the eyes (approved goggles or other approved eye protectors).



**WARNING:** Use suitable floor (service) jacks or chain hoist to raise wheels or tracks off the floor. Always block machine in place with suitable safety stands.



**WARNING:** When servicing or repairing the machine, keep the shop floor and operator's compartment and steps free of oil, water, grease, tools, etc. Use an oil absorbing material and/or shop cloths as required. Use safe practices at all times.



**WARNING:** Some components of this machine are very heavy. Use suitable lifting equipment or additional help as instructed in this Service Manual.



**WARNING:** Engine exhaust fumes can cause death. If it is necessary to start the engine in a closed place, remove the exhaust fumes from the area with an exhaust pipe extension. Open the doors and get outside air into the area.



**WARNING:** When the battery electrolyte is frozen, the battery can explode if (1), you try to charge the battery, or (2), you try to jump start and run the engine. To prevent the battery electrolyte from freezing, try to keep the battery at full charge. If you do not follow these instructions, you or others in the area can be injured.

## STANDARD TORQUE DATA FOR CAP SCREWS AND NUTS

### Tightening of cap screws, nuts

Tighten alternately so that tightening torque can be applied evenly. The numbers in the figure below indicate the order of tightening.

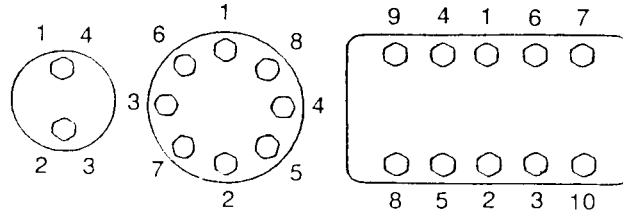

JS00481A

Cap screws which have had Loctite used (white residue remains after removal) should be cleaned with light oil or suitable cleaning solvent and dried. Apply 2-3 drops of Loctite to the thread portion of the cap screw and then tighten.

## Torque table

Tighten cap screws and nuts according to the table below if there are no other special instructions.

Cap Screw Name Size (Size)			M6	M8	M10	M12	M14	M16	M18	M20
<b>Cap Screw</b>	Spanner	[mm]	10	13	17	19	22	24	27	30
		[in.]	0.39	0.51	0.67	0.75	0.87	0.95	1.06	1.18
	Tightening torque	[Nm]	6.9	15.7	32.3	58.8	98.0	137.2	196.0	274.0
		[lb-ft]	5.1	11.6	23.9	43.4	72.3	101.2	144.6	202.4
<b>Socket Head Cap Screw</b>	Spanner	[mm]	5	6	8	10	12	14	14	17
		[in.]	0.20	0.24	0.32	0.39	0.47	0.55	0.55	0.67
	Tightening torque	[Nm]	8.8	21.6	42.1	78.4	117.6	176.4	245.0	343.0
		[lb-ft]	6.5	15.9	31.1	57.8	86.8	130.1	180.8	253.1

# Section 1002

1002

## GENERAL SPECIFICATIONS AND SPECIAL TORQUE SETTINGS

## TABLE OF CONTENTS

TYPE, SERIAL NUMBER AND YEAR OF MANUFACTURE OF THE MACHINE .....	3
Machine.....	3
Engine .....	3
Component serial numbers .....	3
FLUIDS AND LUBRICANTS .....	4
Hydraulic fluid.....	4
Transmission component oil .....	4
Grease .....	4
Engine oil .....	5
Oil viscosity/Oil range.....	5
Fuel .....	6
Anti-freeze/Anti-corrosion.....	6
Environment .....	6
Components made from plastic or resin .....	6
SPECIFICATIONS.....	7
Engine .....	7
Capacities .....	7
Electrical system .....	7
Hydraulic system .....	8
Cylinder .....	8
Control valve .....	9
Swing .....	9
Travel .....	9
Undercarriage .....	9
Attachment.....	10
Weight of components .....	10
DIMENSIONS AND LIMIT OF WEAR AND TEAR OF THE TRACKS SET .....	11
Toothed wheel.....	11
Idler wheel.....	12
Upper roller .....	13
Lower roller .....	14
Track .....	15
DIMENSIONS AND LIMIT OF WEAR AND TEAR OF THE MOBILE JOINTS OF THE ATTACHMENT.....	16
1. Boom foot/Undercarriage .....	16
2. Boom cylinder foot/Undercarriage.....	17
3. Boom cylinder head/Boom .....	17
4. Dipper cylinder foot/Boom .....	18
5. Boom/Dipper .....	18
6. Dipper cylinder head/Dipper.....	18
7. Bucket cylinder foot/Dipper .....	19
8. Connecting rod/Dipper .....	19
9. Compensator/Bucket.....	19
10. Connecting rod/Compensator/Bucket cylinder head.....	20
11. Dipper/Bucket.....	20
SPECIAL TORQUE SETTINGS .....	21
MACHINE OVERALL DIMENSIONS CX130LC/CX160 .....	24
MACHINE OVERALL DIMENSIONS CX130LR .....	25
MACHINE OVERALL DIMENSIONS CX180.....	26



**WARNING:** *This symbol is used in this manual to indicate important safety messages. Whenever you see this symbol, carefully read the message that follows, as there is a risk of serious injury.*

## TYPE, SERIAL NUMBER AND YEAR OF MANUFACTURE OF THE MACHINE

When placing a parts order or making a request for information or assistance, always give you CASE Dealer the type and serial number of the machine concerned.

Enter the required information on the lines below: Type, serial number, year of manufacture of the machine and the serial numbers of hydraulic and mechanical components.

### Machine

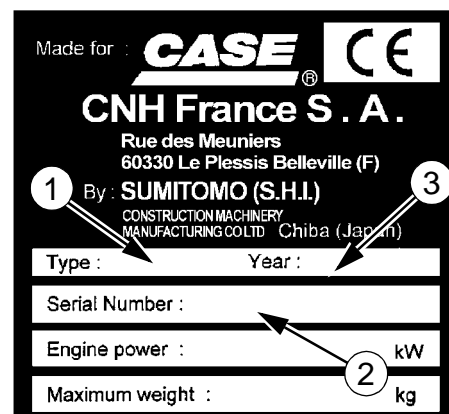

- (1) Type.....
- (2) Serial number.....
- (3) Year of manufacture.....

### Engine

Make and type.....

Serial number.....

### Component serial numbers

Hydraulic pump.....

Swing reduction gear.....

Travel reduction gears.....

Travel control valve.....

Attachment control valve.....

Swing control valve.....

## FLUIDS AND LUBRICANTS

Lubricants must have the correct properties for each application.



**WARNING:** *The conditions of use for individual fluids and lubricants must be respected.*

### Hydraulic fluid

CASE hydraulic fluid is specially designed for high pressure applications and for the CASE hydraulic system. The type of fluid to be used depends on the ambient temperature.

#### Temperate climates

-20°C to +40°C  
Fluid type ISO VG 46  
CASE reference: POHYDR

#### Hot climates

0°C to +60°C  
Fluid type ISO VG 100  
CASE reference: POHYPC

#### Cold climates

-40°C to +20°C  
Fluid type ISO VG 22  
CASE reference: POHYPF

These various grades of fluid must be in conformity with the CASE specification.

### Transmission component oil

Extreme pressure oil used for transmission components inside sealed housings.

Extreme pressure oil TYPE API GL5 GRADE 80W90 or ISO VG 150.

### Grease

The type of grease to use depends on ambient temperature.

#### Temperate and hot climates

-20°C to +60°C  
Extreme pressure grease EP NLGI grade 2 with molybdenum disulphide.

#### Cold climates

-40°C to +20°C  
Extreme pressure grease EP NLGI grade 0.

## Engine oil

CASE engine oil No. 1 is recommended for your engine. This oil ensures correct lubrication of your engine in all working conditions.

If CASE No. 1 Multiperformance or Performance engine oil is not available, use oil corresponding to category API/CG/CF.

**NOTE:** Do not put any Performance Additive or other additive in the sump. Oil change intervals shown in this manual are based on tests carried out on CASE lubricants.



RD97F136



RD97F100

## Oil viscosity/Oil range

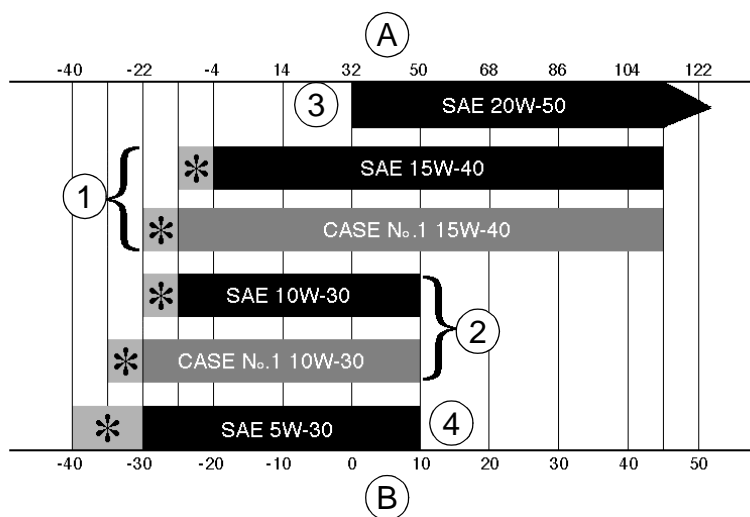

(A) FAHRENHEIT TEMPERATURE

(B) CELSIUS TEMPERATURE

(1) ALL SEASONS

(\*) SHOWS THAT AN ENGINE OIL HEATER OR ENGINE COOLANT SOLUTION HEATER MUST BE USED

(2) WINTER

(3) TROPICAL

(4) ARCTIC

CS98M561

## Fuel

Use fuel that is to ASTM (American Society for Testing and Materials) D975 standard.

Use Grade No. 2 fuel. The use of other types of fuel can result in a loss of power and may cause high fuel consumption.

In cold weather, the use of a mixture of fuels No. 1 and No. 2 is temporarily permitted. Consult your fuel supplier.

If the temperature falls below the fuel cloud point (point at which wax begins to form) the wax crystals will cause power loss or will prevent the engine from starting.

**IMPORTANT:** *In cold weather, fill the fuel tank at the end of the day's work, in order to prevent the formation of condensation.*

## Fuel storage

Long storage can lead to the accumulation of impurities and condensation in the fuel. Engine trouble can often be traced to the presence of water in the fuel.

The storage tank must be placed outside and the temperature of the fuel should be kept as low as possible. Drain off water and impurities regularly.

## Anti-freeze/Anti-corrosion

Use anti-freeze in all seasons to protect the cooling system from corrosion and all risk of freezing.

In environments with a temperature higher than -36°C, use a mixture of 50% ethylene-glycol based anti-freeze.

For areas where the temperature is below -36°C, it is advisable to use a blend of 40% water and 60% anti-freeze.

## Environment

Before carrying out any servicing operation on this machine and before disposing of used fluids or lubricants, always think of the environment. Never throw fluid or oil on the ground and never keep them in leaking receptacles.

Consult your local ecological recycling centre to obtain information on the appropriate means of disposing of these substances.

## Components made from plastic or resin

When cleaning plastic parts, the console, the instrument panel, the gauges, etc., do not use petrol (gasoline), paraffin (kerosene), paint solvents, etc. Use only water, soap and a soft cloth.

The use of petrol (gasoline), paraffin (kerosene), paint solvents, etc, will cause discoloration, cracking or deformation of these components.

## SPECIFICATIONS

CX130LC/CX130LR

CX160

CX180

### Engine

Make ..... Isuzu ..... ← ..... ←

Model ..... BB-4BG1TRA-01DD-4BG1TRA-02 ←

Type: Four stroke, water-cooled, overhead valve, direct injection (electronically controlled), in-line engine with turbo-charger.

Number of cylinders ..... 4 ..... ← ..... ←

Bore and stroke ..... 105x125mm ..... ← ..... ←

Displacement ..... 4329cm<sup>3</sup> ..... ← ..... ←

#### Operating conditions

Idling ..... 1000 tr/mn ..... ← ..... ←

Max speed ..... 2100 tr/mn ..... 2200 tr/mn ..... ←

ECC 1289 power rating ..... 66,2 KW (89cv) ..... 75KW (101cv) ..... ←

Max torque at 1600 rpm ..... 324 Nm ..... 389 Nm ..... ←

### Capacities

Engine oil capacity ..... 15L ..... ← ..... ←

Engine cooling system ..... 17.7 L ..... ← ..... ←

Capacity of the radiator only ..... 6 L ..... ← ..... ←

Fuel tank ..... 250 L ..... ← ..... ←

Hydraulic fluid reservoir capacity ..... 73 L ..... ← ..... ←

Total hydraulic system capacity ..... 123 L ..... 148 L ..... ←

Capacity of the cooler only ..... 7 L ..... ← ..... ←

Travel reduction gear housing capacity ..... 3 L ..... ← ..... ←

Swing drive housing capacity ..... 2.2 L ..... 5 L ..... ←

Idler wheel capacity ..... 160cm<sup>3</sup> ..... 180cm<sup>3</sup> ..... ←

Upper roller capacity ..... 35 to 40 cm<sup>3</sup> ..... 50 to 55 cm<sup>3</sup> ..... ←

Lower roller capacity ..... 190 cm<sup>3</sup> ..... 210 cm<sup>3</sup> ..... ←

**NOTE:** *These capacities are only provided in an indicative manner. To check fluid levels, always use the oil dipstick, sight glasses or the filler cap.*

### Electrical system

Type of system ..... 24 volts negative earth

Alternator amperage ..... 50 A

#### Battery

Number of batteries required ..... 2

Voltage of each battery ..... 12 volts

Capacity ..... 120 Ah

Reserve ..... 160 min

Cold starting capacity at -17°C ..... 800 A

Load for load checking ..... 400 A

#### Starter motor

Voltage ..... 24 volts

Power ..... 4.5 kW

Voltage regulator ..... integrated, not adjustable

## Hydraulic system

### Main hydraulic pump

Double, axial piston, variable flow pump.

Max flow .....	2x123 l/min .....	2x137 l/min .....	←
Displacement.....	2x57.6 cm <sup>3</sup> .....	2x64 cm <sup>3</sup> .....	←

### Hydraulic pilot pump

Fixed flow pump.

Max flow .....	22,8 l/min .....	22 l/min .....	←
Displacement.....	10.7 cm <sup>3</sup> .....	← .....	←

### Pressure settings

Pilot circuit secondary relief valve .....	39 ±1 bar .....	← .....	←
Main relief valve (standard) .....	343±3 bar .....	← .....	←
Main relief valve (higher pressure - 2-stage relief) .....	363±5 bar .....	← .....	←
Secondary relief valves (boom, dipper and bucket) .....	383±5 bar .....	← .....	←
Secondary relief valves (swing).....	279±4 bar .....	← .....	←
Secondary relief valves (travel) .....	430±5 bar .....	353±5 bar .....	←
Secondary relief valve (boom and dipper).....	383±5 bar .....	← .....	←

## Cylinder

### Boom cylinder

Barrel diameter .....	105 mm .....	115 mm .....	←
Rod diameter .....	70 mm .....	80 mm .....	←
Stroke .....	990 mm .....	1179 mm .....	←

### Dipper cylinder

Barrel diameter .....	115 mm .....	125 mm .....	←
Rod diameter .....	80 mm .....	90 mm .....	←
Stroke .....	1108 mm .....	1253 mm .....	←

### Bucket cylinder

Barrel diameter .....	95 mm .....	105 mm .....	←
Rod diameter .....	65 mm .....	75 mm .....	←
Stroke .....	881 mm .....	985 mm .....	←

### Leaks on the cylinder - attachment lowering (without load)

Boom cylinders (rod retracting) .....	≤ 3 mm/5 min .....	≤ 5 mm/5 min .....	←
Dipper cylinder (rod extension).....	≤ 5 mm/5 min .....	≤ 5 mm/5 min .....	←
Bucket cylinder (rod extension) .....	≤ 7 mm/5 min .....	≤ 7 mm/5 min .....	←
Full (at the end of the attachment) .....	≤ 200 mm/10 min .....	≤ 200 mm/10 min .....	←

### Cylinder speeds (in mode S)

Boom raising (open bucket on the floor).....	3.6±0.6 sec. ....	3.8±0.6 sec. ....	←
Boom lowering (open bucket).....	3.0±0.6 sec. ....	3.6±0.6 sec. ....	←
Dipper extension.....	2.6±0.6 sec. ....	3.0±0.6 sec. ....	←
Dipper retraction .....	3.2±0.6 sec. ....	3.6±0.6 sec. ....	←
Bucket opening.....	2.3±0.6 sec. ....	2.4±0.6 sec. ....	←
Bucket closing .....	3.6±0.6 sec. ....	4.2±0.6 sec. ....	←

## Control valve

Five section control valve for dipper, boom acceleration, swing, option and RH travel.

Four section control valve for dipper acceleration, bucket, boom and LH travel.

Load holding valve for boom and dipper.

**CX130LC/CX130LR**

**CX160**

**CX180**

## Swing

Fixed flow, axial piston motor.

Automatic disc brake.

Upperstructure swing speed .....	13.9 rpm.....	11.4 rpm .....	←
Displacement.....	65 cm <sup>3</sup> .....	151 cm <sup>3</sup> .....	←
Work output .....	100 l/min .....	155 l/min .....	←
Reduction ratio .....	17.03 .....	13.34 .....	←
Braking torque.....	≥ 294 Nm.....	≥ 739 Nm.....	←
Minimum brake release pressure .....	29 bar .....	← .....	←
Acceptable hydraulic motor leakage.....	xx l/min.....	← .....	←

## Travel

Two-speed, axial piston motor.

Automatic disc brake.

Slow speed .....	3.8 km/h.....	3.2 km/h .....	2,4 km/h
Fast speed.....	5.5 km/h.....	5,5 km/h .....	4 km/h
Incline that can be overcome.....	70% (35°).....	← .....	←
Tractive force .....	10 000 daN .....	11 300 daN.....	18340 daN
Displacement.....	52.7/34 cm <sup>3</sup> .....	87/49 cm <sup>3</sup> .....	162/95 cm <sup>3</sup>
Work output .....	121 l/min .....	140 l/min.....	137 l/mn
Reduction ratio .....	72.....	57,5.....	43,2
Braking torque (excluding reducer) .....	145 Nm .....	135 Nm.....	483Nm
Number of turns at the sprockets (10 turns)			
Mode "S", fast speed .....	13.4±0.6 sec. ....	12.8±0.6 sec. ....	19.6±0.6 sec.
Mode "S", slow speed.....	20.6±0.7 sec. ....	21.9±0.7 sec. ....	33.4±0.7 sec.
Permitted deviation in travel over a distance of 20 m			
Mode "H", full speed .....	1 m .....	← .....	←
Acceptable hydraulic motor leakage.....	xx l/min.....	← .....	←

## Undercarriage

One-piece undercarriage with welded components.

Lubricated rollers and idler wheels.

Grease type track tension.

Ground pressure

with 500 mm track pads.....	0.39 bar .....	0.47 bar	
with 600 mm track pads.....	0.33 bar .....	0.40 bar .....	0,41 bar
with 700 mm track pads.....	0.29 bar .....	0.33 bar .....	0,36 bar
with 700 mm track pads ( <b>CX130LR</b> ) .....	0.31 bar		
With 800 mm track pads.....	X .....	X.....	0,33 bar
with rubber track pads .....	0.40 bar .....	X.....	X
Tracks tension .....	240 to 260mm .....	260 to 280mm....	280 to 300mm

## Attachment

Break-out force .....	9740 daN .....	11 790 daN .....	←
Break-out force ( <b>CX130LR</b> )	3490 daN		
Penetration force ( <b>CX130LR</b> )	2300 daN		
2.10 m dipper .....	8020 daN		
2.50 m dipper .....	6740 daN		
3.00 m dipper .....	5610 daN		
2.20 m dipper .....	X .....	9300 daN .....	←
2.70 m dipper .....	X .....	8010 daN .....	←
3.10 m dipper .....	X .....	7400 daN .....	←

## Weight of components

Engine .....	361 kg .....	← .....	←
Hydraulic pump .....	90 kg .....	← .....	←
Attachment control valve .....	140 kg .....	← .....	←
Swing motor/reduction gear assembly .....	99 kg .....	221 kg .....	←
Travel motor/reduction gear assembly .....	204 kg .....	247 kg .....	308 kg
Boom cylinder .....	108 kg .....	157 kg .....	←
Dipper cylinder .....	157 kg .....	210 kg .....	←
Bucket cylinder .....	93 kg .....	117 kg .....	←
Counterweight .....	2300 kg .....	3330 kg .....	←
Counterweight ( <b>CX130LR</b> )	3560 kg		
Cab .....	254 kg .....	← .....	←
Turnable bearing .....	188 kg .....	244 kg .....	263 kg
Upperstructure .....	5820 kg .....	6780 kg .....	7670kg
Hydraulic swivel .....	27 kg .....	← .....	31 kg
Undercarriage .....	3880 kg .....	5760 kg .....	6570 kg
Machine without attachment .....	9830 kg .....	12 540kg .....	14240 kg
Attachment .....	2140 kg .....	3030 kg .....	3070 kg
Boom .....	1200 kg .....	1470 kg .....	1780 kg
Boom ( <b>CX130LR</b> )	1080 kg		
Dipper .....	542 kg .....	729 kg .....	805 kg
Dipper ( <b>CX130LR</b> )	610 kg		
Radiator and cooler set .....	48 kg .....	← .....	←
Fuel tank .....	72 kg .....	← .....	←
Hydraulic tank .....	106 kg .....	← .....	←
Idler wheel .....	65 kg .....	82 kg .....	←
Upper roller .....	13 kg .....	17 kg .....	←
Lower roller .....	20 kg .....	36 kg .....	←
Shock absorber .....	63 kg .....	85 kg .....	126 kg
Track 500 mm .....	728 kg .....	1016 kg	
Track 600 mm .....	816 kg .....	1164 kg .....	1257 kg
Track 700 mm .....	970 kg .....	1374 kg .....	1460 kg
Track 800 mm .....	X .....	X .....	1593 kg

# DIMENSIONS AND LIMIT OF WEAR AND TEAR OF THE TRACKS SET

## Toothed wheel

### Dimensions

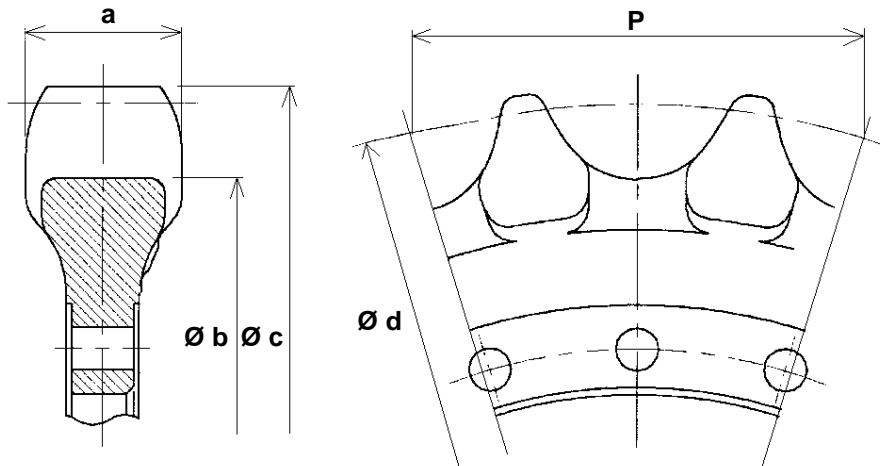

CS01B512

Marking	Dimension (mm)		
		CX130LC CX130LR	CX160 CX180
a	Standard	59	66
	Limit	53	60
Ø b	Standard	584.48	582.5
	Limit	578.5	576.5
Ø c	Standard	652	659
	Limit	646	653
Ø d	Standard	635.48	644.6
	Limit	---	---
P	Standard	171.45	190
	Limit	---	---

### Gauge

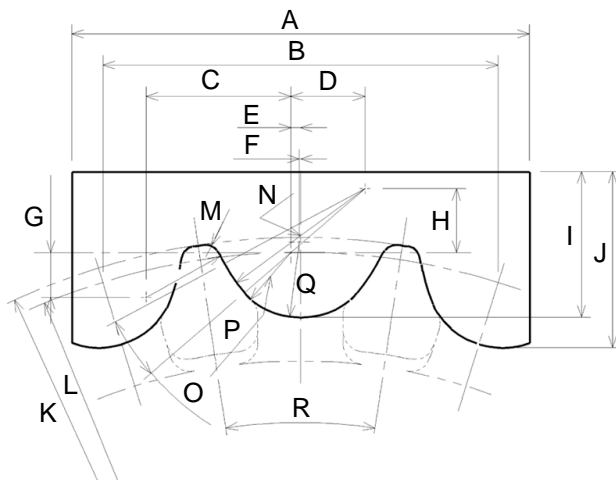

CS01D513

	CX130LC CX130LR	CX160 CX180
A	200	220
B	171.5	190
C	60.48	69.58
D	31	35.61
E	4.23	4.6
F	---	0.52
G	17	21.46
H	26.2	30.6
I	60	70
J	72.9	84.7
K	Ø 652	R329.5
L	PDC 635.48	PDC 322.3
M	R4	R6
N	R66	R76.5
O	---	12.7°
P	R25.5	R29.6
Q	---	R36
R	15.7°	17.1°

# Idler wheel

## Dimensions

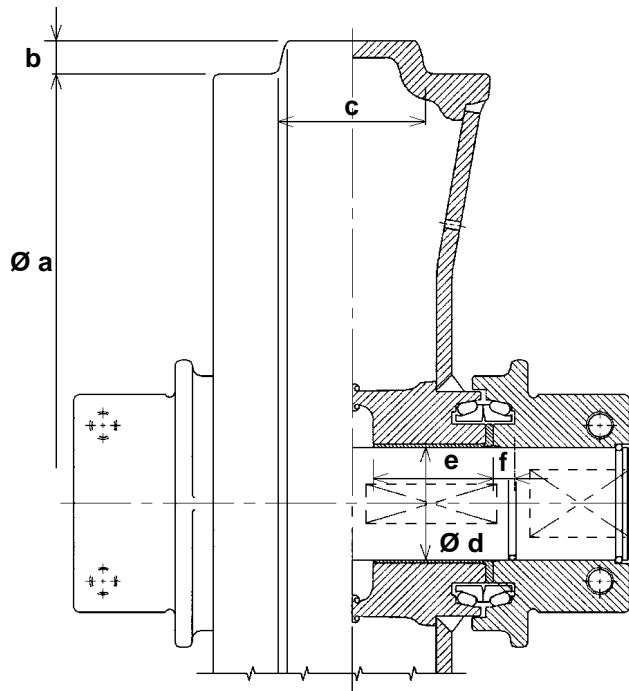

Marking		Dimension (mm)	
		CX130LC CX130LR	CX160 CX180
$\varnothing a$	Standard	510	494
	Limit	506	490
$b$	Standard	17.5	19
	Limit	---	---
$c$	Standard	68	84
	Limit	64	80
$\varnothing d$ (rod)	Standard	55	65
	Limit	54.5	64.5
$\varnothing d$ (ring)	Standard	55	65
	Limit	55.8	65.8
$e$	Standard	55	69
	Limit	54.6	68.6
$f$	Standard	19.9	12.4
	Limit	19.4	11.9

CS01B514

## Gauge

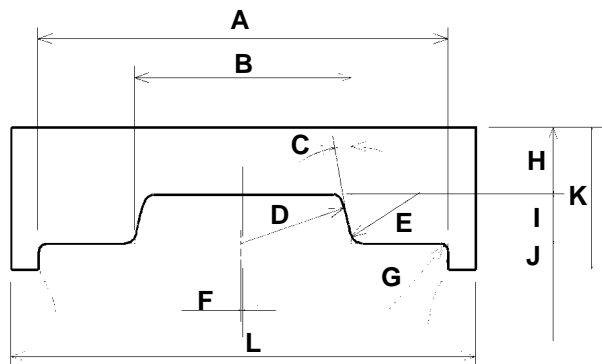

	CX130LC CX130LR	CX160 CX180
<b>A</b>	135	159
<b>B</b>	68	84
<b>C</b>	10°	10°
<b>D</b>	R37	R42
<b>E</b>	2-R4	2-R5
<b>F</b>	3.6	0.6
<b>G</b>	4-R3	4-R3
<b>H</b>	26.5	26
<b>I</b>	17.5	19
<b>J</b>	11	10
<b>K</b>	55	55
<b>L</b>	160	180

CS01D514

Thank you so much for reading.  
Please click the “Buy Now!”  
button below to download the  
complete manual.



After you pay.

You can download the most  
perfect and complete manual in  
the world immediately.

Our support email:

[ebooklibonline@outlook.com](mailto:ebooklibonline@outlook.com)

# Upper roller

## Dimensions

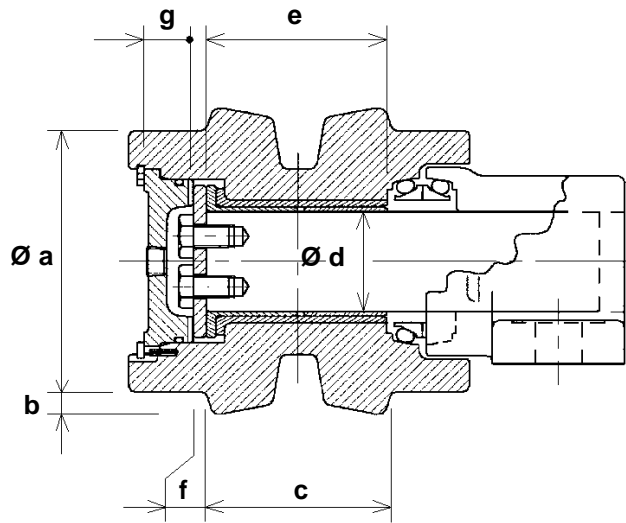

CS01B516

Marking		Dimension (mm)	
		CX130LC CX130LR	CX160 CX180
Ø a	Standard	120	120
	Limit	112	112
b	Standard	10	10
	Limit	---	---
c	Standard	68	85
	Limit	62	79
Ø d (rod)	Standard	40	46
	Limit	39.5	45.5
Ø d (ring)	Standard	40	46
	Limit	40.8	46.8
e	Standard	63	83
	Limit	62.6	82.6
f	Standard	5.5	5.5
	Limit	5	5
g	Standard	22.5	22.5
	Limit	22.5	22

## Gauge

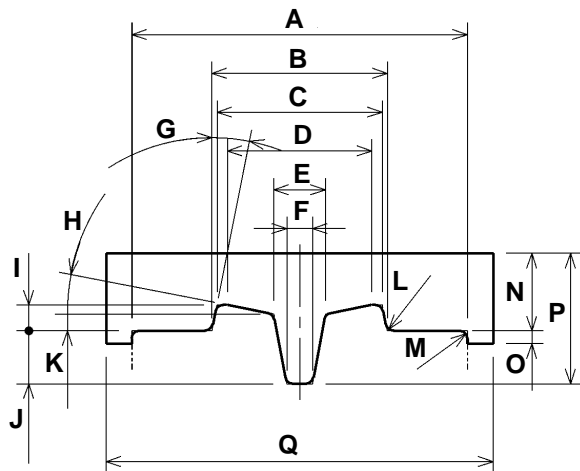

CS01D515

	CX130LC CX130LR	CX160 CX180
A	130	156
B	68	85
C	64	78.6
D	56	68
E	20	24
F	10	16
G	11.3°	18°
H	11°	11.5°
I	10	10
J	20.5	17.5
K	6.5	5.5
L	R3	4-R3
M	R3	8-R3
N	30	35
O	5	10
P	50.5	45
Q	150	175

**<https://www.ebooklibonline.com>**

Hello dear friend!

Thank you very much for reading.

Enter the link into your browser.

The full manual is available for immediate download.

**<https://www.ebooklibonline.com>**