2550

CRAWLER DOZER

Service Manual

Print N° 84414739B English



THIS ALERT SYMBOL SIGNALS IMPORTANT MESSAGES INVOLVING YOUR SAFETY.

Read and heed carefully the safety instructions listed and follow the precautions recommended to avoid potential risks and to safeguard your health and your safety.

You will find this symbol in the text of this Manual referred to the following key words:

WARNING - Cautions directed to avoid improper repair interventions involving potential consequences for the operator's safety.

DANGER - These warnings qualify specifically potential dangers for the safety of the operator or other persons directly or indirectly involved.

IMPORTANT NOTICE

All maintenance and repair interventions explained in this Manual **must be performed exclusively by the Service Organization of the Manufacturer**, observing strictly the instructions explained using, whenever necessary, the recommended specific tools.

Whoever performs the operations reported without following exactly the precautions is responsible on his own, for the damages that may result.

Neither the Factory nor any Organizations in its Distribution Network, including but not limited to national, regional or local distributors, are responsible for any liability arising from any damage resulting from defects caused by parts and/or components not approved by the Factory for use in maintaining and/or repairing products manufactured or merchandized by the Factory.

In any case, no warranty of any kind is made or shall be imposed with respect to products manufactured or merchandized by the Factory, when failures are caused by the use of parts and/or components not approved by the Factory.

SUMMARY

GENERALITIES	SECTION 0
ENGINE	SECTION 1
TRANSMISSION-TORQUE CONVERTER	SECTION 2
STEERING CLUTCHES - BRAKES	SECTION 3
FINAL DRIVES	SECTION 4
UNDERCARRIAGE	SECTION 5
DOZER EQUIPMENT HYDRAULIC SYSTEM	SECTION 6
ELECTRICAL SYSTEM	SECTION 7
AIR CONDITIONING UNIT	SECTION 8

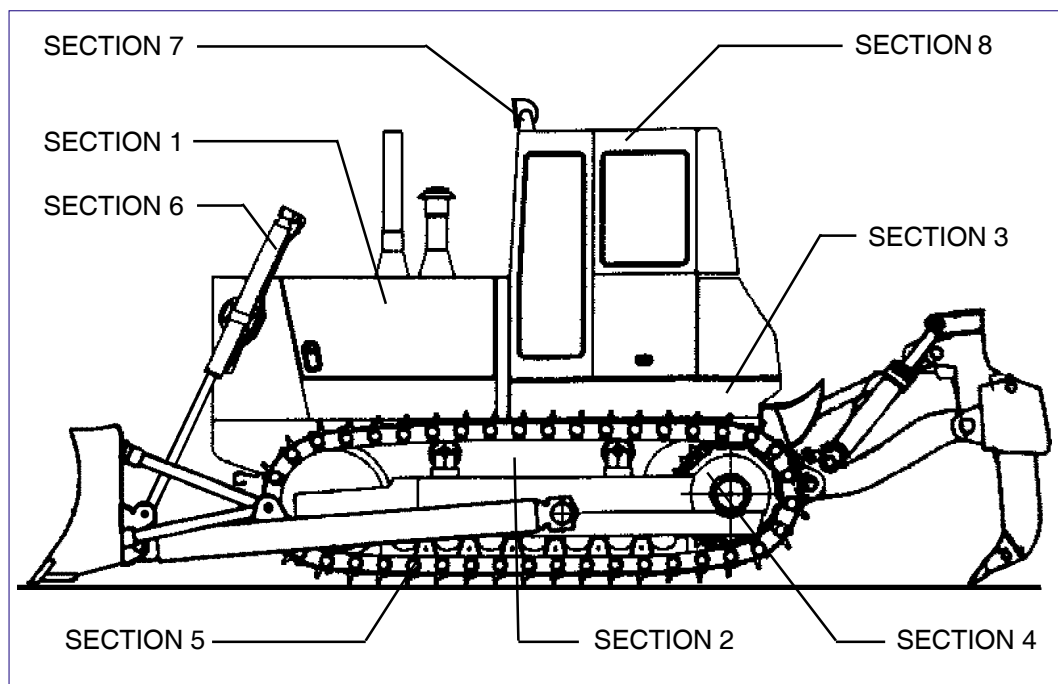

SECTION 0
GENERALITIES

TABLE OF CONTENTS

TITLE	PAGE
SAFETY RULES	I - VIII
TECHNICAL DATA TABLES	1 - 15
GENERAL INSTRUCTIONS	16 - 20
DIAGNOSTIC CHECKS	21
MEASURE UNITS	22
CLASSIFICATION OF STANDARD PARTS	22
TIGHTENING TORQUES	23

<https://www.ebooklibonline.com>

Hello dear friend!

Thank you very much for reading.

Enter the link into your browser.

The full manual is available for immediate download.

<https://www.ebooklibonline.com>

WARNING

**Study this Manual before starting, operating, maintaining, fuelling or servicing the machine.
Read and heed all safety rules before any intervention.**

SAFETY RULES

- Do not allow unauthorised personnel to operate service or maintain this machine.
- Do not wear rings, wrist watches, jewellery, loose or hanging apparels, such as ties, torn clothing, scarves, unbuttoned or unzipped jackets that can catch on moving parts. Wear proper safety equipment as recommended for the job. Examples: hard hat, heavy gloves, ear protection, safety glasses or goggles, reflector vests, respirator. Consult your employer for specific safety equipment requirements.
- Keep operator's compartment, stepping points, grab-rails and handles clear of foreign objects, oil, grease, mud or snow accumulation to minimize the danger of slipping or stumbling.
Clean mud or grease from shoes before attempting to mount or operate the machine.
- Do not jump on or off the machine. Keep two hands and one foot, or two feet and one hand in contact with step grab rails and handles at all times.
- Do not use controls or hoses as hand holds when climbing on or off machine. Hoses and controls are movable and do not provide a solid support. Controls also may be inadvertently moved causing accidental machine or equipment movement.
- Never attempt to operate the machine or its tools from any position other than seated in the operator's seat.
- Keep head, body, limbs, hands and feet inside operator's compartment at all times to reduce exposure to hazards outside the operator's compartment.
- Be careful of slippery conditions on stepping points, hand rails, and on the ground. Wear safety boots or shoes that have a high slip resistant sole material.
- Do not leave the machine until it is completely stopped.
- Check the seat safety belt at least twice a year. If there are signs of wear or fraying or other signs of weakness that could lead to failure, replace it.
- Be sure all protective guards or panels are in place, and all safety devices provided are in place and in good operating conditions.
- Be sure exposed personnel in the area of operation are clear of the machine before moving it or its attachments. **WALK COMPLETELY AROUND** the machine before mounting. Sound horn. Obey flag man, safety signals and signs.
- Before starting machine, check, adjust and lock the operator's seat for maximum comfort and control of the machine.
- Fasten your seat belt (when provided).
- Obey all flag signals and signs.
- Due to the presence on the machine of flammable fluids, never check or fill fuel reservoirs or batteries near open flames, smoking materials or sparks.
- **REMEMBER THAT STARTING FLUID IS FLAMMABLE.** Follow recommendations printed on containers and in the Operation and Maintenance Manual.
- **DO NOT PUNCTURE OR BURN CONTAINERS.**
- Containers must be stored in fresh, well ventilated places, out of reach of unauthorised persons. Follow strictly the instructions provided by the Manufacturer.
- Never use these products near open flames, smoking materials or sparks.

STARTING

- **NEVER START OR OPERATE AN UNSAFE MACHINE.** Before operating a machine, always ensure that any unsafe condition has been satisfactorily remedied.
- Check brakes, steering and attachment controls before moving. Advise the proper maintenance authority of any malfunctioning part or system.

OPERATION

- Do not run the engine of this machine in closed areas without proper ventilation to remove deadly exhaust gases.
- Roll Over Protective Structures are required on loaders, dozers, graders, excavators. **NEVER OPERATE** machines without ROPS.
- Make sure the Operator's compartment is free of foreign objects, especially if not firmly secured. Never use the machine to transport objects, unless proper securing points are provided.
- Check monitoring instruments at start-up and frequently during operation if the brake pressure gauge signals a pressure lower than the minimum operation value, stop immediately the machine.

SAFETY RULES

- DO NOT CARRY RIDERS ON MACHINE
- Study and familiarize with escape routes alternate to normal exit routes.
- Seat belts are required to be provided with Roll Over Protection Structures or cabs. Keep safety belts fastened around you during operation.
- For your personal protection, do not climb on or off machine while machine in motion.
- Make sure that exposed persons in the area of operation are clear of the machine, before starting the engine and operating the equipment. Obey all indications provided by flags and signals.
- NEVER COAST the machine down grades and slopes with the transmission in neutral or neutralized, or power shift type machines, or clutch disengaged on manually shifted machines.
- Do not operate machinery in a condition of extreme fatigue or illness. Be especially careful towards the end of working shift.
- Do not operate machine with brakes out of adjustment.
- Operate the machine at speeds slow enough to ensure complete control at all times.
- Travel slowly over rough terrain, on slopes or near drop-offs, in congested areas or on ice or slippery surfaces.
- When backing, always look to where the machine is to be moved.
Be alert to the position of exposed personnel. DO NOT OPERATE if exposed personnel enter the immediate work area.
STOP THE MACHINE.
- Maintain a safe distance from other machines. Provide sufficient clearance for ground and visibility conditions. Yield right-of-way to loaded machines.
- Maintain clear vision of areas of travel or work. Keep cab windows clean and repaired.
- When machines are operating in tandem, the pusher (rear) must be equipped with the appropriate deflectors to protect the unit in front from the air stream coming from the radiator.
- When pulling or towing through a cable or chain, do not start suddenly at full throttle; take-up slack carefully. Inspect carefully for flaws or troubles before using.
- Avoid kinking chains or cables. Do not pull through a kinked chain or cable to the high stresses and possibility of failure of the kinked area.
Always wear heavy gloves when handling chains or cables.
- Be sure chains and cables are anchored and the anchor points are strong enough to handle the expected load. Keep exposed personnel clear of anchor points and cables or chains.
- DO NOT PULL UNLESS OPERATOR'S COMPARTMENT OF MACHINES INVOLVED ARE PROPERLY GUARDED AGAINST POTENTIAL CABLE OR CHAIN BACKLASH.
- Be alert to soft ground conditions close to newly constructed walls. The fill material and weight of the machine may cause the wall collapse under the machine.
- In darkness, check area of operation carefully before moving in with machine. Use all lights provided. Do not move into area of restricted visibility.
- If engine has a tendency to stall for any reason under load or idle, report this for adjustment to proper maintenance authority immediately.
Do not continue to operate machine, until condition has been corrected.
- On machines supplied with suction radiator fans, be sure to periodically check engine exhaust parts for leaks, as exhaust fumes are dangerous to the operator.
- In case of enclosed cabs, always let open a discharge to the outside, to ensure air circulation.
- Operators must know thoroughly the performances of the machine they are operating.
When working on slopes or near sudden level drops of the terrain, avoid areas where ground is loose or soft since rolling-over or loss of control of machine could result.
- Where noise exposure exceeds 90 dBA for 8 hours, wear approved ear protection.
- When counterweights are provided, do not work machine if they have been removed.
- Overtaking manoeuvres must be performed only when absolutely necessary and unavoidable.
Beware of possible uneven terrains, poor visibility conditions, the presence of other machinery or persons out of sight.
- Operate the machine at a speed adequate to the working conditions in the site and slow enough to ensure complete control at all times.
- Check monitoring instruments at start-up and frequently during operations.
In case of abnormal condition warnings, stop immediately the machine.
- Never use the machine as a work platform or scaffolding, nor other inappropriate operations (i.e pushing railway cars, trucks or other machines).

SAFETY RULES

- Be alert of people in the operating area of the machine. When operating a machine, know what clearances will be encountered, overhead doors, cables, pipes, bearing load limitations of ground, bridges, floors or ramps.
- When roading, find-out what conditions are likely to be encountered, clearances, traffic congestion, type of road surfacing, etc.
Beware of fog, smoke or dust elements that obscure visibility.
- When crossing gullies or ditches, move at an angle with reduced speed after ensuring ground conditions will permit a safe traverse.
- Explore the working area to identify potential risks such as: slopes, overhangs, pits, demolition rubble, fires, ravines, ditches, soft terrain, heavy traffic, crowded parking areas, closed ambients. In such conditions, proceed with extreme care.
- Whenever possible, avoid going over obstacles such as rough terrain, rocks, logs highly irregular ground, steps, ditches, railroad tracks. When obstructions must be crossed, do so with extreme care at an angle, if possible. Reduce speed, shift-down.
Ease up to the break over point, pass the balance point slowly on the obstruction and ease down on the other side.
- In steep down-hill operation, do not allow engine to over-speed. Select proper gear before starting down grade.
- Avoid side hill travel, whenever possible. Drive up and down the slope. Should the machine slipping sideways, turn it immediately downhill.
- The grade of slope you should attempt will be limited by factors such as condition of the ground, load being handled, type of machine, speed of machine and visibility.
- There is no substitute for good judgement when working on slopes.
- Avoid operating equipment too close to an overhang or high wall, either above or below the machine. Be on the look-out for caving edges, falling objects and slides. Beware of concealment by brush and undergrowth of these danger.
- When pushing-over trees, the machine must be equipped with proper overhead guarding. Never allow a machine to climb up on the root structure particularly while the tree is being felled.
Use extreme care when pushing over any tree with dead branches.
- Avoid brush piles, logs or rocks. **NEVER DRIVE OVER THEM** or other surface irregularities that brake traction with the ground, especially when on slopes or near drop-offs.
- Be alert to avoid changes in traction conditions that could cause loss of control. **DO NOT DRIVE** on ice or frozen ground conditions when working the machine on steep slopes or near drop-offs.
- Working in virgin and rough terrains is characterized by the presence of all the perils and risks listed above. In these conditions, it is emphasised the danger represented by large tree limbs (possibly falling on the machine), large roots (acting as a leverage under the machine when up-rooted causing the roll-over of the unit) etc..

STOPPING

- When the machine is stopped for whatever reason, follow the instructions of chapters “**Stopping the machine**” and “**Stopping the engine**” of the Operation and Maintenance Instruction Manual.
- Always remember to position the transmission drive control in neutral and engage the control lock to secure the machine.
- Set parking brake.
- **NEVER LEAVE THE MACHINE UNATTENDED** with the engine running.
- Always before leaving the operator’s seat and after making sure all people are clear of the machine, slowly lower the attachments or tools flat to the ground in a positive ground support position.
- Return the controls in neutral position. Place the gearshift lever in neutral and shut-off the engine. Lock the gearshift lever, switch-off and lock the starter switch.
- Park in a non- operating and no-traffic area or as instructed. Park on firm level ground if possible. Where not possible, position machine at a right angle to the slope, making sure there is no danger of uncontrolled sliding movements. Set parking brake.
- If parking in traffic lanes cannot be avoided, provide appropriate flags, barriers, flares and signals as required. Also provide advance warning signals in the traffic lane of approaching traffic.
- Keep head, body, limbs, hands and feet away from blade, arms, bucket or ripper when in raised position. Always disconnect the master switch before any intervention (i.e. cleaning, repairing, maintaining, refuelling etc.). Do the same when parking for prolonged periods of time to avoid accidental or unauthorized starting.
- Never lower attachments or tools other than seated in operator’s seat. Sound horn. Make sure area near the attachment is clear. Lower the attachment slowly. **DO NOT USE FLOAT POSITION** of hydraulic system.

SAFETY RULES

- Securely block the machine and lock it every time you leave it unattended. Return keys to authorized security. Heed all shut-down operations of the Operation and Maintenance Instruction Manual are followed. Every time you leave the machine, engage parking brake (if equipping unit).
- Keep shoes free of mud or grease before climbing or driving the machine.
- Never attempt to operate the machine or its tools from any position other than seated in the operator's seat.

MAINTENANCE

GENERALITIES

- Before operating or performing any intervention on the machine:
 - read carefully all the rules contained by this Manual;
 - read and obey all safety related plates and instructions located on the machine.
- Do not allow unauthorized personnel to perform any maintenance operation. Do not perform maintenance operation without prior authorization. Follow all recommended maintenance and service procedures.
- Keep operator's compartment free of all loose objects that are not properly secured.
- Do not wear rings, wrist watches, jewellery, loose or hanging apparels, such as ties, torn clothing, scarves, unbuttoned or unzipped jackets that can catch on moving parts.
Wear proper safety equipment as recommended for the job. Examples: hard hat, heavy gloves, ear protection, safety glasses or goggles, reflector vests, respirator. Consult your employer for specific safety equipment requirements.
- Do not use controls or hoses as handholds when climbing on or off the machine. These components are movable and do not provide a solid support. Controls may also be moved unintentionally causing accidental machine or equipment movements.
- Do not jump on or off the machine. Keep two hands and one foot, or two feet and one hand in contact with steps and grab rails and handles at all times.
- Do not perform any service operation on the machine with a person seated in the operator's compartment, unless he is an authorized operator co-operating in the operation to be performed.
- Keep operator's compartment, stepping points, grab-rails and handles clear of foreign objects, oil, grease, mud or snow accumulation to minimize the danger of slipping or stumbling. Clean mud or grease from shoes before attempting to mount or operate the machine.
- Always block with external supports any linkage or part on machine that requires work under the raised linkage, part or machine. Never allow anyone to walk under or be near unblocked raised equipment. Unless you are positively sure that total safe condition exist, avoid staying under raised equipment, even if blocked.
- Never place head, body, limbs, fingers, feet or hands into exposed portions between uncontrolled or unguarded scissor points of machine without first providing secure blocking.
- Never perform interventions with engine running, except as called for in a Manual. Do not wear loose clothing or jewellery near moving parts.
- When servicing or maintenance require access to areas that cannot be reached from the ground, use a ladder or step platform that meet local and national regulations, to reach the service point. If such ladder or platform are not available, use the machine hand holds and steps as provided. Perform all service or maintenance carefully.
- Shop and/or field service platforms or ladders must be constructed and maintained in accordance with local and national regulations.
- Disconnect batteries and TAG all controls according to current regulations to warn that work is in progress. Block machine and all attachments that must be raised according to current regulations.
Due to the presence of flammable fluids, never check or fill fuel tanks, batteries, nor use starting fluid near lighted smoking materials or open flames.
- BRAKES ARE INOPERATIVE when manually released for servicing. Provisions must be made to maintain control of the machine by blocking or other means.
- The fuel filling nose must be kept constantly inside the filling neck. Keep this contact from the beginning to the end of the fuelling operation to avoid the possibility that sparks due to static electricity are generated.
- Use only designated towing or attaching points. Use care in making attachments. Make sure pins and/or locks are secure before pulling. Stay clear of drawbars, cables or chains under load.

SAFETY RULES

- To move a disabled machine, use a trailer or a low-boy, if available. In case towing is needed, use all necessary signals required by local and national regulations, and follow the directions provided in this Manual.
- To load/unload a machine from transporter, choose a level surface ensuring firm support to the wheels of truck or trailer.
Use strong access ramps, with adequate height and angle. Keep surface free of mud, oil or slippery materials.
- Anchor the machine securely to the bed of truck or trailer and block wheels or tracks with appropriate wedges.
- Never align holes with fingers or hands; always use appropriate aligning tools.
- Eliminate all sharp edges and burrs from re-worked parts.
- Use only approved grounded auxiliary power sources for heaters, chargers, pumps and similar equipment to reduce the hazards of electrical shocks.
- Lift and handle heavy parts with a lifting device of proper capacity. Be sure parts are supported by proper slings and hooks. Use lifting eyes if provided. Watch-out for people in the vicinity.
- Never pour gasoline or diesel fuel into open, wide and low containers. Never use gasoline, solvent or other flammable fluid to clean parts. Use exclusively qualified, non-flammable, non-toxic commercial solvents.
- When using compressed air for cleaning parts, use safety glasses with side shields or goggles. Limit pressure to 2 bar, in accordance with local and national regulations.
- Do not run the engine in closed areas without proper ventilation to remove deadly exhaust fumes.
- Do not smoke or permit any open flames or spark near when re-fuelling or handling flammable materials.
- Do not use an open flame as a light source to look for leaks or for inspection anywhere on the machine.
- Make sure that all mechanic's tools are in good conditions. NEVER USE tools with mushroomed heads or frayed. Always wear eye protections.
- Move with extreme care when working under the machine, its attachments and on or near them. Always wear protective safety equipment as required, such as hard hat, goggles, safety shoes, ear plugs.
- When performing operations requiring running of the engine, have a qualified operator in the operator's seat at all times with the mechanic on sight. Place the transmission in neutral and set the brakes and safety lock. KEEP HANDS AND CLOTHING AWAY FROM MOVING PARTS.
- For field service, move machine to level ground, if possible, and block it.
If work on an incline is absolutely necessary, first block machine and its attachments securely, then move it to level ground as soon as possible.
- Do not trust worn and /or kinked chains and cables: do not use them for lifting or pulling operations.
To handle them, always use heavy gloves.
- Avoid kinking chains or cables.
Do not pull through a kinked chain or cable to the high stresses and possibility of failure of the kinked area.
Always wear heavy gloves when handling chains or cables.
- Be sure chains and cables are anchored and the anchor points are strong enough to handle the expected load.
- Keep exposed personnel clear of anchor points and cables or chains.
- DO NOT PULL UNLESS OPERATOR'S COMPARTMENT OF MACHINES INVOLVED ARE PROPERLY GUARDED AGAINST POTENTIAL CABLE OR CHAIN BACKLASH.
- Keep the area where maintenance operations are performed CLEAN and DRY. Eliminate immediately all water and oil spillages.
- Do not pile oily or greasy rags; they represent a fire hazard. Store in closed metal container.
- Before starting machine, check, adjust and lock the operator's seat for maximum comfort and control of the machine.
Be sure exposed personnel in the area of operation are clear of the machine before moving it or its attachments.
Sound horn.
- Rust inhibitors are volatile and flammable Use only in well ventilated areas.
Keep open flames away - DO NOT SMOKE - Store containers in a cool well ventilated place, secure against unauthorised personnel.
- Do not carry loose objects in pockets that might fall unnoticed into open compartments.
- Wear proper protective equipment such as safety goggles or safety glasses with side shields, hard hat, safety shoes, heavy gloves when metal or other particles are apt to fly or fall.
- Wear welders protective equipment such as dark safety glasses, helmets, protective clothing, gloves and safety shoes, when welding or burning.
Wear dark safety glasses near welding zones.
DO NOT LOOK AT ARC WITHOUT PROPER EYE PROTECTION.

SAFETY RULES

- Know your jacking equipment and its capacity. Be sure the jacking point used on the machine is appropriate for the load to be applied. Be sure the support of the jack at the machine and under jack is appropriate and stable. Loads lifted by hydraulic jacks are always dangerous. Transfer load to appropriate blocking as a safety measure, before proceeding with service or maintenance work, according to local or national regulations.
- Steel cables are frayed after prolonged use; always wear appropriate protections (heavy gloves, goggles etc.).
- Handle all parts carefully. Keep hands and fingers away from structures, gears or moving parts. Use and wear always the appropriate protections
- Compressed air systems can have water deposits created by moisture condensation due to changes of atmospheric conditions. If required, discharge deposits, as instructed.
- Do not adjust engine fuel pump when machine is moving.
- Do not lubricate the machine with engine running.
- Do not run the engine with air intakes, door or protections open.

STARTING

- Do not run the engine in closed areas without proper ventilation to remove deadly exhaust fumes.
- Do not place head, body, limbs, feet, hands or fingers, near rotating fans or belts. Be especially alert near pusher fans.
- **REMEMBER THAT STARTING FLUID IS FLAMMABLE.** Follow recommendations printed on containers and in the Operation and Maintenance Manual.
- Containers must be stored in fresh, well ventilated places, out of reach of unauthorised persons. Follow strictly the instructions provided by the Manufacturer. **DO NOT PUNCTURE OR BURN CONTAINERS.**

ENGINE

- Loosen the radiator cap very slowly, to release pressure from the system, before removing it. All coolant level top-ups must be performed with engine OFF.
- Avoid that flammable materials touch exhaust parts. Should this be possible, provide the necessary protections.
- Do not run engine when refuelling and use care if the engine is hot due to the increased possibility of a fire if fuel is spilled.
- Never attempt to check or adjust fan belts when engine is running.

ELECTRICAL SYSTEM

- Always disconnect batteries prior to any intervention on machine or electrical system (cleaning, repair, maintenance).
- Should booster batteries be used, remember to connect both ends of the booster cables in the proper manner (+) with (+) and (-) with (-). Avoid short-circuits of the terminals. Follow thoroughly the instructions of this Manual.
- Before any intervention, make sure that the main switch is OFF.
- **BATTERY GAS IS HIGHLY FLAMMABLE.** Leave battery box open to improve ventilation when recharging batteries. Never check charge by placing metal objects across the posts. Keep sparks or open flames away from batteries. Do not smoke near battery to guard against the possibility of causing an explosion.
- Before any intervention, make sure that there are no fuel or electrolyte leakages; eliminate them before proceeding with further work.
Do not charge batteries in closed areas: ensure enough ventilation to prevent the possibility of accidental explosions due to accumulation of gases generated during the recharging.

HYDRAULIC SYSTEM

- Fluid escaping under pressure from a very small hole can be almost invisible and can have sufficient force to penetrate the skin. Use a piece of cardboard or wood to search for suspected pressure leaks.
DO NOT USE HANDS. If injured by escaping fluid, see a doctor at once. Serious infection or reaction can develop if proper medical treatment is not administered immediately.
- Stop the engine and release all pressures in the system before removing panels, housings, plugs or covers.
- In case pressures must be measured, use instruments of adequate capacity. Always follow the recommended procedures.

SAFETY RULES

TOOLS

- Keep head, body, limbs, feet, fingers or hands away from bucket, blade or ripper when in raised position.
- Prior to any intervention, install all safety devices according to current rules and regulations. In case equipment on the machine must be operated by hydraulic systems, remember to proceed only after seating in the operator's compartment.
Make sure that there are no persons in the operating area of the machine. Alert people before operating using the horn and by voice. Move the equipment very carefully.
- Do not use machine to transport loose objects, unless proper devices for this purpose are provided.
- Clutches and brakes of this machine and eventual auxiliary equipment and attachments (such as operating cylinder or winches control valves) must always be properly adjusted in accordance with the instructions provided by the Manuals of the Manufacturer. Never perform adjustments with engine running, except when called for by the above instructions.
- Do not proceed with adjustments with engine running, unless required by prescribed procedures.
- When changing work shifts, check that there are no screws and/or mounting brackets loose. If required tighten as instructed in this publication.

WARNING

On machines having hydraulically, mechanically, and/or cable controlled equipment (such as shovels, loaders, dozers, excavators etc.) be certain the equipment is lowered to the ground before servicing, adjusting and/or repairing. If it is necessary to have the hydraulically, mechanically, and/or cable controlled equipment partially or fully raised to gain access to certain items, be sure the equipment is suitably supported by means other than the hydraulic lift cylinders, cable and/or mechanical devices used for controlling the equipment.

SAFETY RULES

SAFETY RULES FOR SEALS

VITON SEALS (fluoro - elastomer)

Seals, especially Viton made O-rings (Normally coloured red) are used in systems operating at high temperatures, considering the resistance of this material to the effects of heat. However, should this material be subject to temperatures exceeding 315 °C (600 °F) - in practice only in case of a fire or subject to the flame of an oxyacetylene torch - hydrofluoric acid is generated. **This acid is highly corrosive and can cause severe burns** if in contact with the skin.

every time it is necessary to intervene on components equipped with Viton rings, and there is the suspicion that they have been exposed to excessive temperatures the following procedures must be applied:

- 1) inspect visually, without touching them, all seals that appear to be damaged by excessive heat. They appear black and sticky;
- 2) check the type of material of the seals to identify if they are made with Viton, performing the test illustrated in the enclosure, on spare parts;
- 3) if it was found or there is a reasonable doubt that Viton made components are involved, the contaminated area **MUST** be decontaminated prior to proceeding with further operations;
- 4) wear neoprene or PVC gloves and protective glasses or face shield, wash accurately the contaminated area with a solution of water lime (available at tile stores) dissolved in water until a milky looking liquid is obtained. Rinse accurately with steam or running water;
- 5) eliminate the materials removed and the protective gloves in safe manner avoiding burning them.

TEST TO DISTINGUISH RUBBER MATERIAL (BUNA N) FROM "VITON" (FLUORO ELASTOMER)

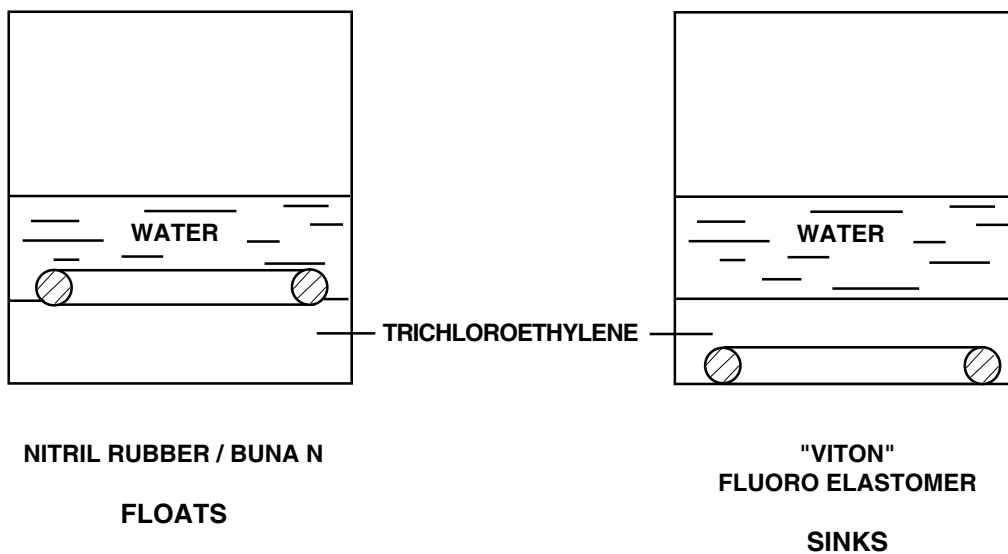

2550

CRAWLER DOZER

TECHNICAL DATA TABLES

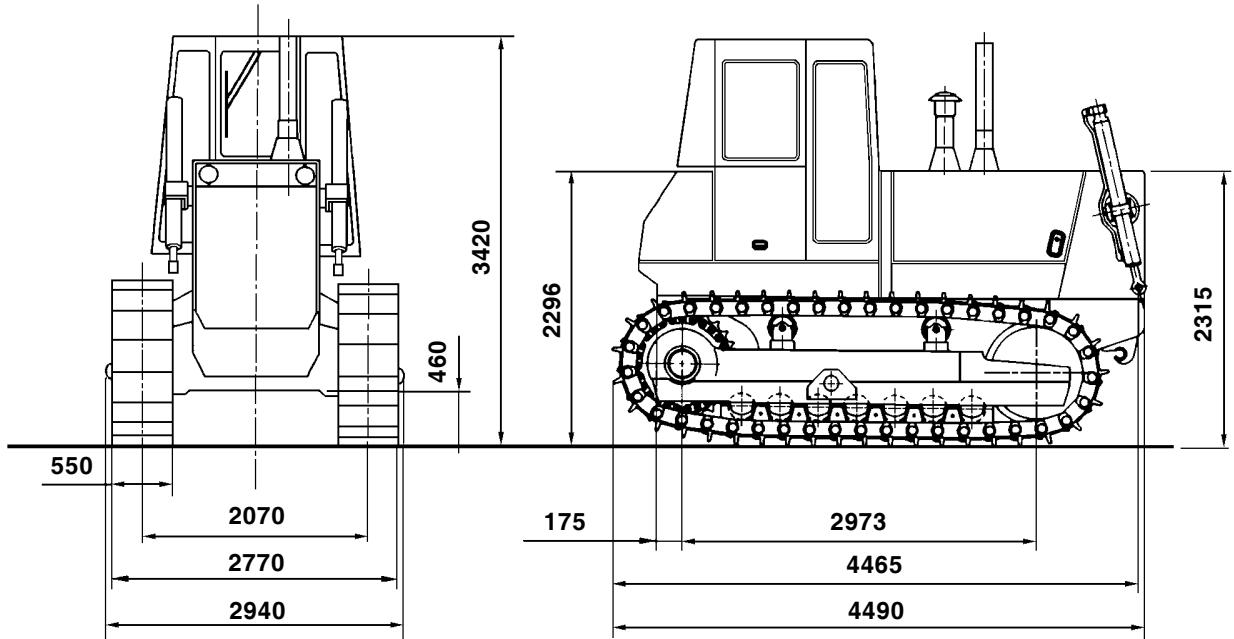

BULLDOZER HSU + RIPPER

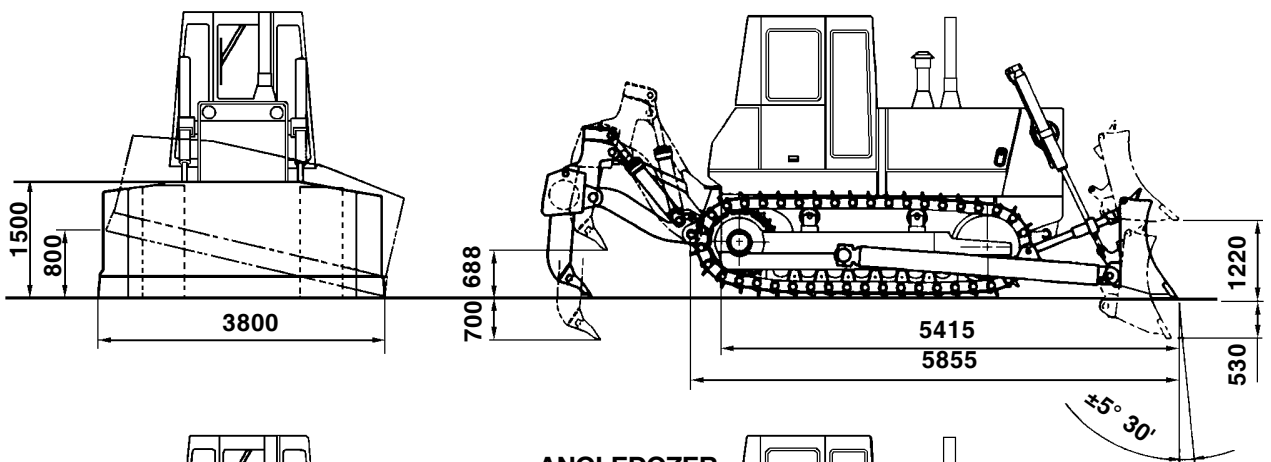

ANGLEDZOZER

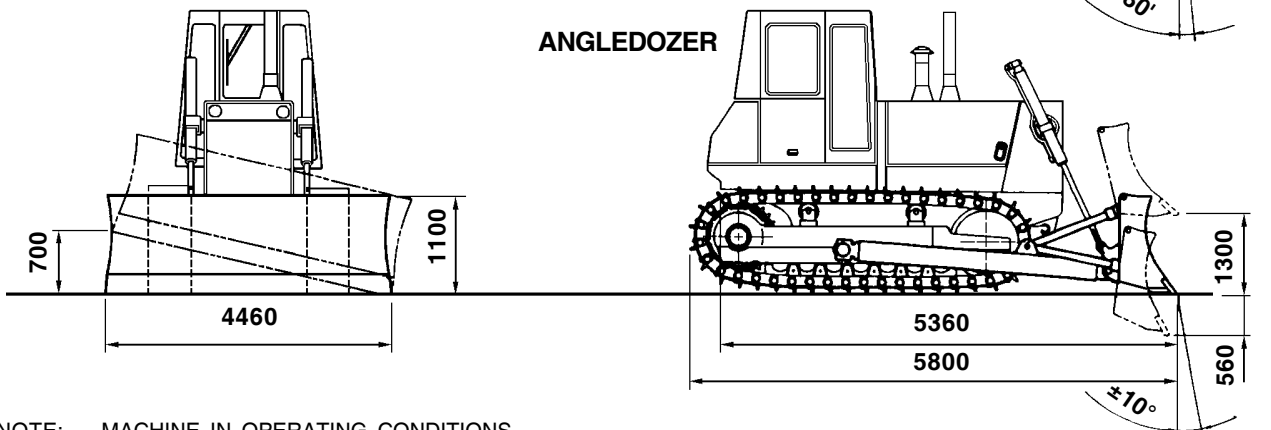

NOTE: - MACHINE IN OPERATING CONDITIONS
 - HEIGHT OF GROUSERS: 71.4 mm
 - The figure includes optional tools

L. 502

DIMENSIONS	Overall length (bare tractor)		mm	4 490	
	Overall length (with semi-U blade)		mm	5855	
	Overall length (with angledozer blade)		mm	5 800	
	Overall width (bare tractor)		mm	2 940	
	Overall width (with semi-U blade)		mm	3650	
	Overall width (with angledozer blade)		mm	4 460	
	Overall height (to tip of exhaust pipe)		mm	3 400	
	Overall height (with ROPS cab)		mm	3 420	
	Track gauge		mm	2 070	
	Minimum distance from ground		mm	460	
	Length of track on ground		mm	2 973	
	Track shoe width		mm	550	
	MASS	Shipping weight (including ROPS cab, blade lift cylinders, lubricants, coolant, 10% fuel)		kg	21 845
Operating weight with semi-U (HSU) blade and ROPS cab		kg	27000		
Operating weight with angle (HA) blade, ROPS cab and ripper		kg	26 400		
PERFORMANCE	SPEEDS	Fwd 1 st	km/h	3.7	
		Fwd 2 nd	km/h	6.1	
		Fwd 3 rd	km/h	10.9	
	NOISE LEVEL	Inside cab standard (Lpa)	ISO 6394	dB	83
			CEE 86/662	dB	83
		Outside (Lwa)	ISO 6394	dB	113
			CEE 86/662	dB	113
GROUND PRESSURE	(Track shoes width 550 mm)				
	With semi-U (HSU) blade and ROPS		bar	0.8085	
	With angle (HA) blade, ROPS cab and ripper		bar	0.791	
	With semi-U (HSU) blade, ROPS cab and ripper		bar	0.910	
GRADEABILITY	(1 st speed)		degree	45	

ENGINE	Model	CUMMINS 6CTAA8.3
	Type	Diesel, 4 - cycle, direct injection, turbocharged, aftercooled
	Bore x stroke	114 x 135 mm
	Displacement	8268 cm ³
	Number of cylinders	6
	Net flywheel power (SAE J1349)	177 kW at 2200 rpm
	Net flywheel power (DIN 6270)	240 CV / 179 kW at 2200 rpm
	Net flywheel power (ISO 9249)	177 kW at 2200 rpm
	Net flywheel power (CEE 80/1269)	177 kW at 2200 rpm
	Max torque	114,6 daN m (101 kgm) at 1400 rpm
	Governed speed	2200 rpm
	Low idling	890 rpm
	Fuel consumption ratio (max torque)	205 gr / kWh
	Cranking motor	24 V - 7.5 kW
	Alternator	28 V - 65 A
	Battery	12 V - 180 Ah x 2
	Radiator	Air - water with tubes and line cores
	Core size	1090 x 874 x 114 mm
	Radiator cap pressure	0.75 bar
	Fan	Blower steel sheet, 7 blades, diameter 900 mm
Air cleaner	Dry type, two state with safety element and centrifugal separator, restrictor indicator	
Muffler	Horizontal type with dust ejector, dimensions 258 x 545 mm	
Aftercooler	Air - air with tubes and line cores	
Core size	552 x 555 x 82 mm - Aluminium	
ATH	-100 °C	
Air flow	23 kg/min	
Max pressure	4 bar	
Fan	diameter 500 mm	
POWER TRAIN SYSTEM	Torque converter	1 stage, 1 fase, diameter 16" Stall ratio 3.28 : 1 Impeller shaft moves thru a set of gear: – implement pump – transmission pump + converter pump + oil recovery pump – steering clutches pump
	Transmission	Countershaft, full power shift with remote hydraulic pilot control, 3 gears forward and 3 gears reverse obtained through 5 multidisc clutches actuated by single piston. Transmission with 3 clutches having centrifugal valves. FWD and REV modulating valves, speeds engagement modulating valve.

POWER TRAIN SYSTEM	Torque converter - transmission pump	Combined with converter oil circulation pump and oil recovery pump		
	Capacity (2100 rpm)	96.5 l/min		
	Rated pressure	14 bar		
	Full flow (including lubrication)	193 l/min		
	Transmission filters	Suction	Metal gauze and magnetic rod 100 micron filter capacity, without by-pass	
		Return	Paper type with by-pass valve	
	Transmission regulating valve	Mounted on converter case		
	Relief valve pressure (at 10 l/min flow)	10 ± 0.5 bar		
	Safety hand lever valve	In lock position inhibits the gear engagement and the engine cranking, and applies the parking brakes		
	Pilot control valve (manipulator)	On - off type with hydraulic detents. Semi-open pattern.		
Position	3FWD	2FWD	1FWD	
	-	N	N	
	3REV	2REV	1REV	
Drive shaft	Two U-joint and telescopic shaft type			
Nominal length	256 mm			
Power take - off provision	Output from transmission reverse gear shaft. CW rotation, viewed from the rear side of the machine			
Max output torque capacity (@ 0 output rpm)	241.5 daN m			
Max output speed (@ 0 output torque)	2277 rpm			
N. of splines	24			
Module	2.58			
Bevel gear set	Straddle mounted pinion. Modular assembly			
Ratio	13 / 38 = 1 : 1.293			
Steering clutch	Multidisc, wet type, spring actuated, hydraulically released			
N. of friction discs	11 (each clutch)			
Total single friction area	7612 cm ²			
Disc I.D.	280 mm			
Disc O.D.	350 mm			
Friction material	Sinterized			

POWER TRAIN SYSTEM	Brake	Wet, Single band, bi-directional. Brake mechanism is actuated by a spring and released by the transmission oil system, in the braking operation. It is actuated by steering system during the steering operation. The band wear is recovered with automatic adjuster device. Warning output light for excessive wear.
	Drum diameter	406 mm
	Band width	130 mm
	Total friction area	1604 cm ²
	Final drive	Countershaft double reduction
	Ratio	1 : 12.410
	Sprocket	9 bolt-on segment type
	Total N. of teeth	27
Pitch diameter	936.62 mm	
Tooth width	95 mm	
Steering and braking control system	The steering system is operated by two hand levers installed on the left side of the operator compartment. The lever travel, applies a modulated pressure in the steering control valve obtaining two proportional pressures. First pressure operate the disengagement of steering clutch. Second pressure is equal to zero until the first pressure reaches 17.5 bar (50% of lever travel) than applies positively the steering brakes. The service brake system is operated negatively by a brake pedal. Pedal acutation cuts with modulation the back pressure of the brake piston and applies, with springs, the brakin load.	
Steering system pump	Gear type	
Flow (@ rated engine speed)	65.5 l/min	
Rated pressure	38 ± 38.7 bar	
Steering system filters	Suction Return	Metal gauze and magnetic rod 100 micron filter capacity, without by-pass. Spin on type with by-pass valve 10 micron filter capacity.

TRACK	Track frames		Box section type, oscillating beam is supported by resilient pads on the forward portion of the track frame. Rear of track frame pivots about sprocket shaft.
	Track oscillation (total travel of idler wheel)		410 mm
	Lubrication system		Rollers, idlers, sprocket, pins and bushing, sealed and permanently lubricated.
	Idlers		With hydraulic track adjuster
	Carrier roller (each side)		2
	Track roller (each side)		7
	Track shoe 550 mm (600 mm - 700 mm)		Assembly type single grouser, 41 on each side.
Grouser height		71.4	
Link pitch		216 mm	
IMPLEMENTS HYDRAULIC SYSTEM	MAIN HYDRAULIC PUMP	Type	Gear type
		Capacity at governed speed	2121 l/min
		Relief valve pressure	190 bar
	MAIN CONTROL VALVE	Type	Three spools Lower - raise - float control. Blade left and right tilt control. Available for rear additional implement control.
Specifications		Tandem circuit, flow reduction valve on tilt circuit. Capacity 70 l/min (nominal), safety valves on each circuit.	
FRONT IMPLEMENT SINGLE CONTROL LEVER	Functions		
		HYDRAULIC TANK	Type

IMPLEMENTS HYDRAULIC SYSTEM	HYDRAULIC TANK FILTERS	Suction	Immersed in tank, metal gauze and 250 micron filter capacity, with by-pass (pressure cal. 0.2 bar).
		Return	Immersed in tank, microfiber type and 10 micron filter capacity with by-pass (pressure cal. 2.5 bar).
	LIFT CYLINDERS	Type	Double acting. Stroke end valves and quick drop valves on cylinders heads.
		Cylinder bore	110 mm
		Piston stroke	1302 mm
		Outside diameter of piston rod	63 mm
		Max. distance between pins	1982 mm
		Min. distance between pins	980 mm
IMPLEMENT (BULLDOZER)	Type		Multiple box section with lower reversible cutting sectors and lower edge reinforced with ribbings.
	Blade support		Brace type (tilt cylinder on right). Equistatic device for uniformstress distribution on push beams.
	DIMENSIONS	Blade width	3800 mm
		Blade height	1500 mm
	PERFORMANCE	Max. lifting height from ground	1220 mm
		Max. lowering depth from ground	530 mm
		Max. tilt	800 mm
		Cutting angle range	5° 30'
		Moldboard volume	7 m ³
		Raising average velocity (2100 rpm)	0.371 m/s
	TILT - HYDR. CYLINDER (BULLDOZER)	Type	Double acting
		Cylinder bore	160 mm
		Piston stroke	140 mm
		Outside diameter of piston rod	80 mm
		Max. distance between pins	1150 mm
		Min. distance between pins	1010 mm

IMPLEMENT (ANGLEDZER)	Type	Hydraulic angledozer. Multiple box section with lower reversible cutting sectors and lower edge reinforced with ribbings.	
	Blade support	C - frame, welded box section.	
	DIMENSIONS	Blade width	4460 mm
		Blade height	1100 mm
	PERFORMANCE	Max. lifting height from ground	1300 mm
Max. lowering depth from ground		560 mm	
Max. tilt		700 mm	
Cutting angle range		5°	
Moldboard volume		4.1 m ³	
TILT - HYDR. CYLINDER (BULLDOZER)	Raising average velocity (2100 rpm)	0.394 m/s	
	Type	Double acting	
	Cylinder bore	140 mm	
	Piston stroke	124 mm	
	Outside diameter of piston rod	80 mm	
	Max. distance between pins	1569 mm	
Min. distance between pins	1445 mm		
IMPLEMENT (RIPPER)	Type	Parallelogram type ripper PD20 two double acting cylinders. Cylinders support and tool beam in box section weld fabricated structure (three positions adjustable)	
	N. of shanks	3	
	Bore x piston rod diameter	125 x 70 mm	
	Stroke	590 mm	
	Closed length	1015 mm	
	Extended length	1605 mm	
	Penetration force	48150 daN	

MASS

Engine assembly		1230 kg
Radiator assembly		140 kg
Fuel and hydraulic tank assembly		320 kg
Rear transmission housing		3953 kg
Steering control valve assembly		10 kg
Torque converter assembly		–
Transmission assembly		726 kg
Final drive assembly (each side)		–
Hull frame assembly		2000 kg
Track frame (each side)		1070 kg
Idler assembly (each side)		230 kg
Track roller assembly (single board)		18.5 kg x 5
Track roller assembly (double board)		19.3 kg x 2
Carrier roller assembly		52 kg x 2
Track shoe assembly (each side)	550 mm wet type	1910 kg
Main control valve assembly		37 kg
Engine flap door		31 kg
Transmission underguard (front)		40 kg
Transmission underguard (rear)		41 kg
Gear box underguard		30 kg
Straight tildozer assembly		1340 kg
Blade angle		1810 kg
Blade HSU		2090 kg
C - frame angle		1460 kg
Tilt cylinder assembly		170 kg
Blade lift cylinder assembly		180 kg x 2
Cab assembly		650 kg
Rops support		644 kg
Battery (each)		49 kg



Suggest:

If the above button click is invalid.

Please download this document

first, and then click the above link

to download the complete manual.

Thank you so much for reading

FLUIDS AND LUBRICANTS

ITEM	Q.TY (Liter)	CNH PRODUCT	REFILL (International classification)	VISCOSITY	AMBIENT TEMPERATURE (C°)
COOLING SYSTEM	65	PREMIUM ANTI-FREEZE MS1710	Mixture of water and antifreeze at 50%. The mixture provides oxidation, foaming, corrosion, scaling and freezing protection properties down to - 35 °C (- 31 °F).	-	-
FUEL TANK	495	-	Diesel fuel ASTM N.2-D type TT of good quality and brand	-	-
ENGINE	18	AKCELA NO. 1 ENGINE OIL	API CH4 ACEA E5	SAE 15W-40 SAE 10W-30	-15 °C ÷ +40 °C -25 °C ÷ +20 °C
BEVEL GEAR STEERING CLUTCHES BRAKES	82	AKCELA NO. 1 ENGINE OIL	API CH4 ACEA E5	SAE 10W-30	-15 °C ÷ +40 °C -20 °C ÷ +20 °C
CONVERTER AND TRANSMISSION	67	AKCELA HY-TRAN@ULTRA	CNH MAT 3505 MS1209	SAE 10W	-20 °C ÷ +40 °C
HYDRAULIC SYSTEM ANGLEDOZER VERSION (mechanical)	100	AKCELA HYDRAULIC EXCAVATORS FLUID-MS1230	ISO VG-46 DIN PART 2 HVI	GRADE NT	-20 °C ÷ +40 °C
FINAL DRIVES (each)	43	HYPOIDE 90 AKCELA GEAR 135 HEP	API GL5 MIL - L - 2105 D	SAE 80W90	-20 °C ÷ +40 °C
TRACK IDLERS AND ROLLERS	9	CASE NO. 1 ENGINE OIL	API CH4 ACEA E5	SAE 10W-30	-15 °C ÷ +40 °C -25 °C ÷ +20 °C
GREASE FITTINGS	-	CASE MOLYDISULFIDE GREASE	-	-	-
CAB TILTING SYSTEM	0.5	CNH MS1209 HY-TRAN@ULTRA	ATF Type A Suffix A ALLISON C4	SAE 10W	-20 °C ÷ +40 °C

Notes: - In case of a lower classification of CH4 engine oil, the change must be done every 250 hours.
- The change interval must be reduced when present sulfur in the fuel exceed to 0,5% or the ambient temperature exceed to 38 °C.

If the content of sulfur of the fuel exceeds 0.5%, change the engine oil as follows:

as 0.5% sulfur	Normal Service interval
0.5 to 1%	Half normal interval
up to 1%	One quarter normal interval

<https://www.ebooklibonline.com>

Hello dear friend!

Thank you very much for reading.

Enter the link into your browser.

The full manual is available for immediate download.

<https://www.ebooklibonline.com>