

1838 Uni-Loader
Service Manual

Table of Contents

| | Description | Section No. | Form No. |
|--------------------------|--|--------------|-------------|
| General | | | |
| | | Tab 1 | |
| | Loctite Product Chart | | 8-98900 |
| | Torque Specifications | 1001 | 8-71601 |
| | Fluids and Lubricants | 1002 | 7-60550 |
| Engine | | | |
| | | Tab 2 | |
| | Removal and Installation and Radiator Removal and Installation | 2001 | 7-61400 |
| | Specification Details | 2002 | 7-60560 |
| | Special Service Tools | 2003 | 7-61670 |
| | Kubota Workshop Manual V2203-D1-B | | 97897-01082 |
| Fuel System | | | |
| | | Tab 3 | |
| | Fuel System and Filters | 3410 | 7-61640 |
| | Injection Pump Timing | 3412 | 7-61650 |
| Electrical | | | |
| | | Tab 4 | |
| | Removal and Installation of Electrical Components | 4001 | 7-61410 |
| | Electrical Specifications, Troubleshooting and Schematics | 4002 | 7-60570 |
| | Battery | 4003 | 8-11361 |
| Power Train | | | |
| | | Tab 6 | |
| | Removal and Installation of Power Train Components | 6001 | 7-61420 |
| | Hydrostatic System Troubleshooting | 6002 | 7-60580 |
| | Piston Pumps | 6004 | 7-61430 |
| | Drive Motors | 6005 | 7-61530 |
| | Pump Drive Coupling | 6006 | 7-61590 |
| | Sprockets Chains and Axles | 6007 | 7-61630 |
| | Wheels and Tires | 6008 | 8-11461 |
| Hydraulics | | | |
| | | Tab 8 | |
| | Remove and Installation of Hydraulic Components | 8001 | 7-61600 |
| | Hydraulic Schematics, Specifications and Troubleshooting | 8002 | 7-60591 |
| | Cleaning the Hydraulic system and Hydrostatic System | 8003 | 8-11521 |
| | Gear Pump | 8004 | 7-61490 |
| | Loader Control Valve | 8005 | 7-61500 |
| | Auxiliary Control Valve | 8006 | 7-61510 |
| | Self-Leveling Control Valve | 8007 | 7-61520 |
| | Backhoe Control Valve - D100 Backhoe | 8008 | 7-61610 |
| | Cylinders | 8009 | 7-61330 |
| Mounted Equipment | | | |
| | | Tab 9 | |
| | Control Linkages, Pedals, Levers and Chains | 9001 | 7-60600 |
| | Loader | 9002 | 7-61340 |
| | ROPS Canopy, Seat, Seat Belts and Operators Compartment | 9003 | 7-61350 |
| | Backhoe - D100 Backhoe | 9005 | 7-61680 |

Section 1001

STANDARD TORQUE SPECIFICATIONS

CASE CORPORATION
700 State Street
Racine, WI 53404 U.S.A.

CASE CANADA CORPORATION
3350 South Service Road
Burlington, ON L7N 3M6 CANADA

Rac 8-71601

© 1994 Case Corporation
Printed in U.S.A.
Issued November, 1991

TABLE OF CONTENTS

TORQUE SPECIFICATIONS - DECIMAL HARDWARE 2

TORQUE SPECIFICATIONS - METRIC HARDWARE 3

TORQUE SPECIFICATIONS - STEEL HYDRAULIC FITTINGS 4

TORQUE SPECIFICATIONS - STEEL HYDRAULIC FITTINGS 5

TORQUE SPECIFICATIONS - DECIMAL HARDWARE

Use the torques in this chart when special torques are not given. These torques apply to fasteners with both UNC and UNF threads as received from suppliers dry, or when lubricated with engine oil. Not applicable if special graphities, Molydisulfide greases, or other extreme pressure lubricants are used.

| Grade 5 Bolts, Nuts, and Studs | | |
|---|--------------|---------------|
|  | | |
| Size | Pound-Inches | Newton metres |
| 1/4 inch | 108 to 132 | 12 to 15 |
| 5/16 inch | 204 to 252 | 23 to 28 |
| 3/8 inch | 420 to 504 | 48 to 57 |
| Size | Pound-Feet | Newton metres |
| 7/16 inch | 54 to 64 | 73 to 87 |
| 1/2 inch | 80 to 96 | 109 to 130 |
| 9/16 inch | 110 to 132 | 149 to 179 |
| 5/8 inch | 150 to 180 | 203 to 244 |
| 3/4 inch | 270 to 324 | 366 to 439 |
| 7/8 inch | 400 to 480 | 542 to 651 |
| 1.0 inch | 580 to 696 | 787 to 944 |
| 1-1/8 inch | 800 to 880 | 1085 to 1193 |
| 1-1/4 inch | 1120 to 1240 | 1519 to 1681 |
| 1-3/8 inch | 1460 to 1680 | 1980 to 2278 |
| 1-1/2 inch | 1940 to 2200 | 2631 to 2983 |

| Grade 8 Bolts, Nuts, and Studs | | |
|--|--------------|---------------|
|  | | |
| Size | Pound-Inches | Newton metres |
| 1/4 inch | 144 to 180 | 16 to 20 |
| 5/16 inch | 288 to 348 | 33 to 39 |
| 3/8 inch | 540 to 648 | 61 to 73 |
| Size | Pound-Feet | Newton metres |
| 7/16 inch | 70 to 84 | 95 to 114 |
| 1/2 inch | 110 to 132 | 149 to 179 |
| 9/16 inch | 160 to 192 | 217 to 260 |
| 5/8 inch | 220 to 264 | 298 to 358 |
| 3/4 inch | 380 to 456 | 515 to 618 |
| 7/8 inch | 600 to 720 | 814 to 976 |
| 1.0 inch | 900 to 1080 | 1220 to 1465 |
| 1-1/8 inch | 1280 to 1440 | 1736 to 1953 |
| 1-1/4 inch | 1820 to 2000 | 2468 to 2712 |
| 1-3/8 inch | 2380 to 2720 | 3227 to 3688 |
| 1-1/2 inch | 3160 to 3560 | 4285 to 4827 |

NOTE: Use thick nuts with Grade 8 bolts.

<https://www.ebooklibonline.com>

Hello dear friend!

Thank you very much for reading.

Enter the link into your browser.

The full manual is available for immediate download.

<https://www.ebooklibonline.com>

TORQUE SPECIFICATIONS - METRIC HARDWARE

Use the following torques when specifications are not given.

These values apply to fasteners with coarse threads as received from supplier, plated or unplated, or when lubricated with engine oil. These values do not apply if graphite or Molydisulfide grease or oil is used.

| Grade 8.8 Bolts, Nuts, and Studs | | |
|---|--------------|---------------|
|  | | |
| Size | Pound-Inches | Newton metres |
| M4 | 24 to 36 | 3 to 4 |
| M5 | 60 to 72 | 7 to 8 |
| M6 | 96 to 108 | 11 to 12 |
| M8 | 228 to 276 | 26 to 31 |
| M10 | 456 to 540 | 52 to 61 |
| Size | Pound-Feet | Newton metres |
| M12 | 66 to 79 | 90 to 107 |
| M14 | 106 to 127 | 144 to 172 |
| M16 | 160 to 200 | 217 to 271 |
| M20 | 320 to 380 | 434 to 515 |
| M24 | 500 to 600 | 675 to 815 |
| M30 | 920 to 1100 | 1250 to 1500 |
| M36 | 1600 to 1950 | 2175 to 2600 |

| Grade 10.9 Bolts, Nuts, and Studs | | |
|---|--------------|---------------|
|  | | |
| Size | Pound-Inches | Newton metres |
| M4 | 36 to 48 | 4 to 5 |
| M5 | 84 to 96 | 9 to 11 |
| M6 | 132 to 156 | 15 to 18 |
| M8 | 324 to 384 | 37 to 43 |
| Size | Pound-Feet | Newton metres |
| M10 | 54 to 64 | 73 to 87 |
| M12 | 93 to 112 | 125 to 150 |
| M14 | 149 to 179 | 200 to 245 |
| M16 | 230 to 280 | 310 to 380 |
| M20 | 450 to 540 | 610 to 730 |
| M24 | 780 to 940 | 1050 to 1275 |
| M30 | 1470 to 1770 | 2000 to 2400 |
| M36 | 2580 to 3090 | 3500 to 4200 |

Grade 12.9 Bolts, Nuts, and Studs



Usually the torque values specified for grade 10.9 fasteners can be used satisfactorily on grade 12.9 fasteners.

TORQUE SPECIFICATIONS - STEEL HYDRAULIC FITTINGS

| Tube OD Hose ID | Thread Size | Pound- Inches | Newton metres |
|--------------------------------|----------------|------------------|------------------|
| 37 Degree Flare Fitting | | | |
| 1/4 inch 6.4 mm | 7/16-20 | 72 to 144 | 8 to 16 |
| 5/16 inch 7.9 mm | 1/2-20 | 96 to 192 | 11 to 22 |
| 3/8 inch 9.5 mm | 9/16-18 | 120 to 300 | 14 to 34 |
| 1/2 inch 12.7 mm | 3/4-16 | 180 to 504 | 20 to 57 |
| 5/8 inch 15.9 mm | 7/8-14 | 300 to 696 | 34 to 79 |
| Tube OD Hose ID | Thread Size | Pound- Inches | Newton metres |
| 3/4 inch 19.0 mm | 1-1/16-12 | 40 to 80 | 54 to 108 |
| 7/8 inch 22.2 mm | 1-3/16-12 | 60 to 100 | 81 to 135 |
| 1.0 inch 25.4 mm | 1-5/16-12 | 75 to 117 | 102 to 158 |
| 1-1/4 inch 31.8 mm | 1-5/8-12 | 125 to 165 | 169 to 223 |
| 1-1/2 inch 38.1 mm | 1-7/8-12 | 210 to 250 | 285 to 338 |

| Tube OD Hose ID | Thread Size | Pound- Inches | Newton metres |
|-------------------------------------|----------------|------------------|------------------|
| Straight Threads with O-ring | | | |
| 1/4 inch 6.4 mm | 7/16-20 | 144 to 228 | 16 to 26 |
| 5/16 inch 7.9 mm | 1/2-20 | 192 to 300 | 22 to 34 |
| 3/8 inch 9.5 mm | 9/16-18 | 300 to 480 | 34 to 54 |
| 1/2 inch 12.7 mm | 3/4-16 | 540 to 804 | 57 to 91 |
| Tube OD Hose ID | Thread Size | Pound- Inches | Newton metres |
| 5/8 inch 15.9 mm | 7/8-14 | 58 to 92 | 79 to 124 |
| 3/4 inch 19.0 mm | 1-1/16-12 | 80 to 128 | 108 to 174 |
| 7/8 inch 22.2 mm | 1-3/16-12 | 100 to 160 | 136 to 216 |
| 1.0 inch 25.4 mm | 1-5/16-12 | 117 to 187 | 159 to 253 |
| 1-1/4 inch 31.8 mm | 1-5/8-12 | 165 to 264 | 224 to 357 |
| 1-1/2 inch 38.1 mm | 1-7/8-12 | 250 to 400 | 339 to 542 |

| Split Flange Mounting Bolts | | |
|------------------------------------|------------------|------------------|
| Size | Pound- Inches | Newton metres |
| 5/16-18 | 180 to 240 | 20 to 27 |
| 3/8-16 | 240 to 300 | 27 to 34 |
| 7/16-14 | 420 to 540 | 47 to 61 |
| Size | Pound- Feet | Newton metres |
| 1/2-13 | 55 to 65 | 74 to 88 |
| 5/8-11 | 140 to 150 | 190 to 203 |

MAINTENANCE LOCATIONS

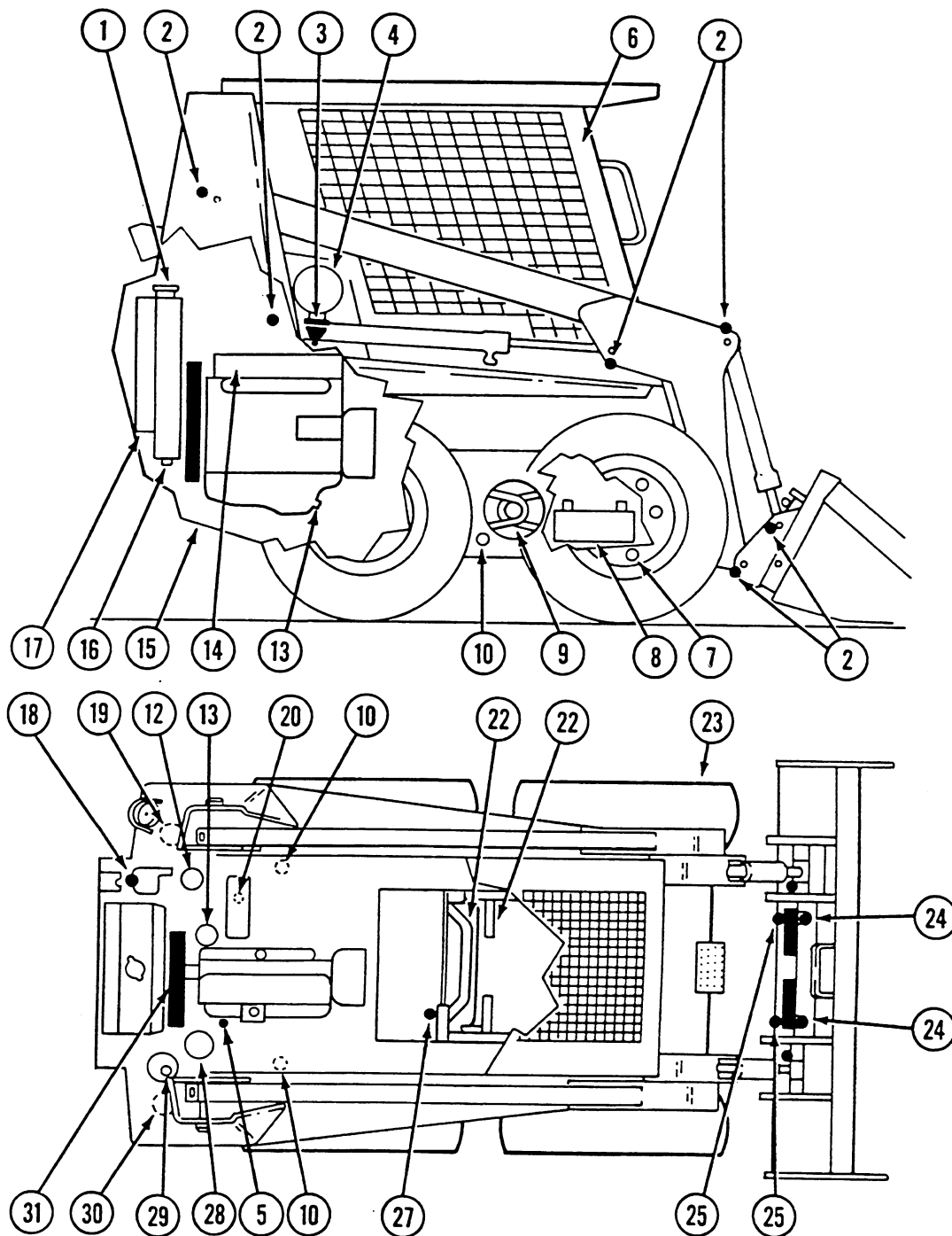

894L93

IF YOU OPERATE THE MACHINE IN SEVERE CONDITIONS, LUBRICATE AND SERVICE THE MACHINE MORE FREQUENTLY. IT IS RECOMMENDED THAT YOU SEE YOUR CASE DEALER FOR INFORMATION ON THE SYSTEMGARD LUBRICATION ANALYSIS SYSTEM.

SEE YOUR OPERATORS MANUAL FOR MAINTENANCE OF SAFETY RELATED ITEMS AND FOR DETAILED INFORMATION OF THE SERVICE ITEMS ON THIS CHART. OPERATORS AND SERVICE MANUALS ARE AVAILABLE FOR THIS MACHINE FROM YOUR CASE DEALER.

NOTE: The CASE CORPORATION reserves the right to make improvements in design or changes in specifications at any time without incurring any obligation to install them on units previously sold.

Section

2001

**ENGINE REMOVAL AND INSTALLATION AND
RADIATOR REMOVAL AND INSTALLATION**

2001

SPECIFICATIONS

Cooling system capacity 12 U.S. quarts (11.3 litres)

SPECIAL TORQUES

Front engine mounts.....80 to 96 pound-inches (109 to 130 Nm)

Rear engine mount..... 150 to 180 pound-inches (203 to 244 Nm)

Cap screws that fasten the tandem pump to the pump mounting plate Apply 271 Loctite on the threads and tighten to 38 to 42 pound-feet (52 to 57 Nm)

Cap screws that fasten the radiator mounting brackets 15 to 20 pound-inches (1.68 to 2.25 Nm)

SPECIAL TOOLS

Order special tools from one of the following addresses

In the U.S.A. and Canada

OTC Division SPX Corporation
655 Eisenhower Drive
Owatonna, MN 55060

In Europe

VL Church Ltd.
P.O. Box 3, Daventry
Northants, NN11 4NF
England

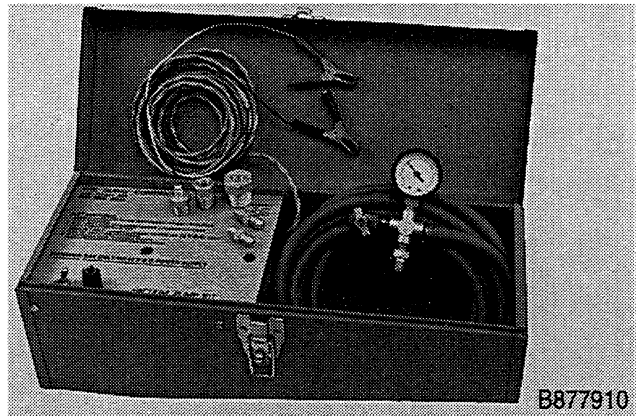

B877910

CAS-10192 Vacuum Pump

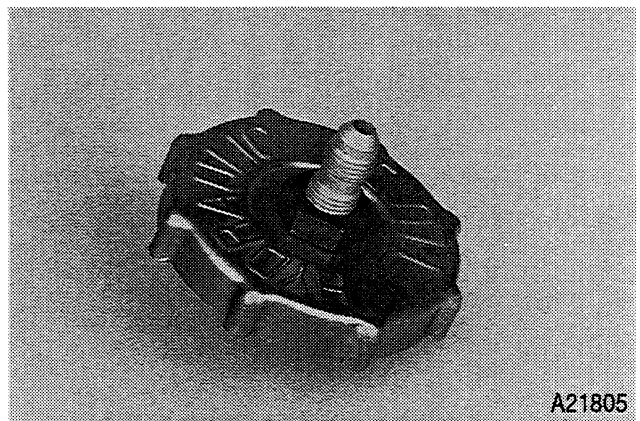

A21805

CAS-1871 Adapter

ENGINE REMOVAL

STEP 1

Move the operators compartment forward according to the instructions in Section 9003.

STEP 2



Open the rear door.

STEP 3

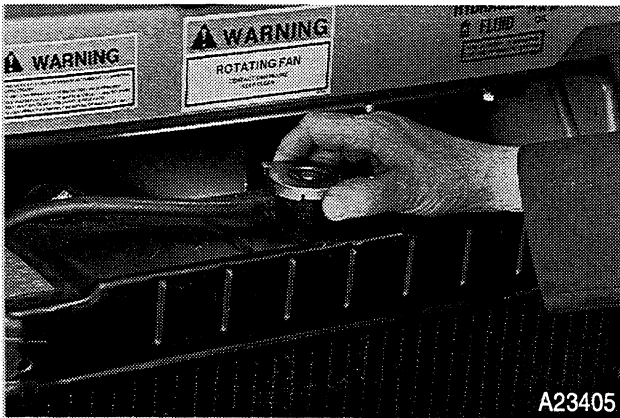

Remove the radiator cap.

STEP 4

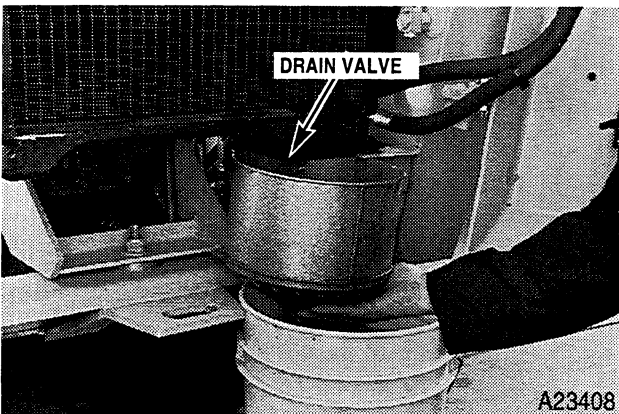

Open the drain valve and drain the cooling system. The cooling system capacity is approximately 12 U.S. quarts (11.3 litres) of coolant.

Rac 7-61400

STEP 5

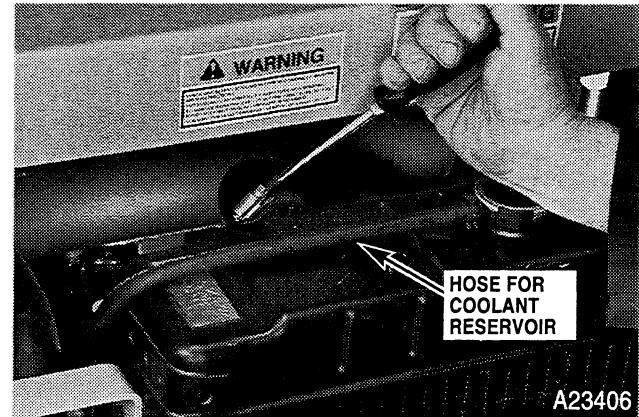

Loosen the clamp and disconnect the top hose from the radiator. Disconnect the hose for the coolant reservoir from the radiator. Install a plug in the coolant reservoir hose.

STEP 6

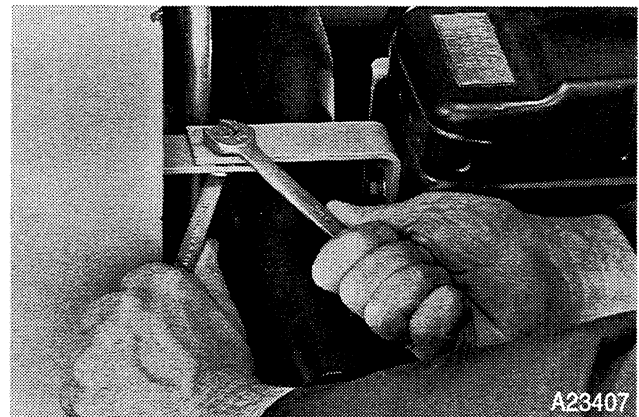

Loosen and remove the self-locking nut, flat washer and bolt that fasten the top left radiator support to the frame.

STEP 7

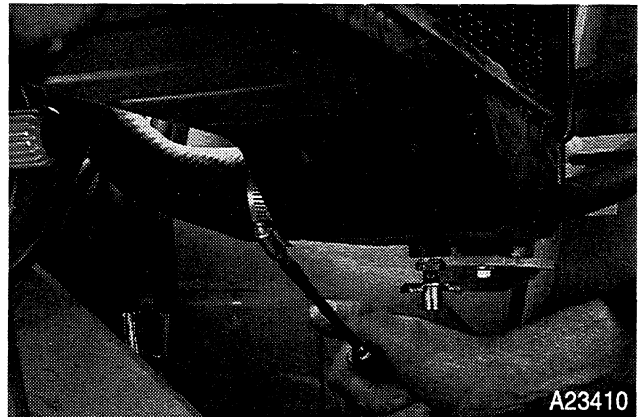

Loosen the clamp and disconnect the bottom hose from the radiator.

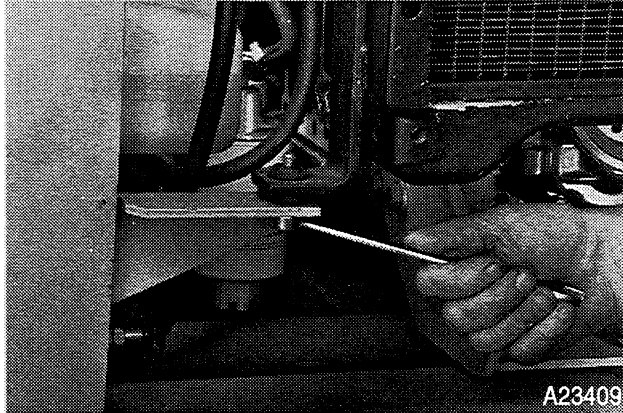
STEP 8

Loosen and remove the cap screw and flat washers that fasten the radiator to the left radiator mounting bracket.

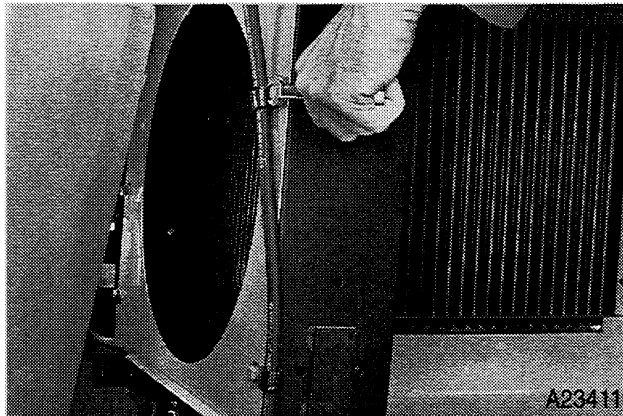
STEP 9

Pull the left side of the radiator to the rear. Loosen and remove the cap screws and flat washers that fasten the clamps for the coolant reservoir hose to the radiator. Put the hose for the coolant reservoir out of the way.

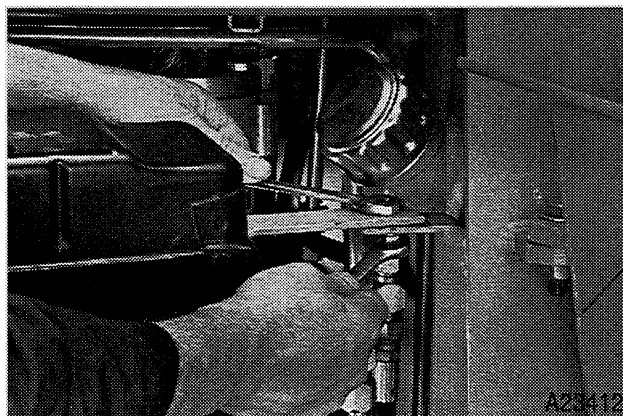
STEP 10

Loosen and remove the hardware that fastens the right side of the radiator to the frame and the radiator upper and lower mounting bracket.

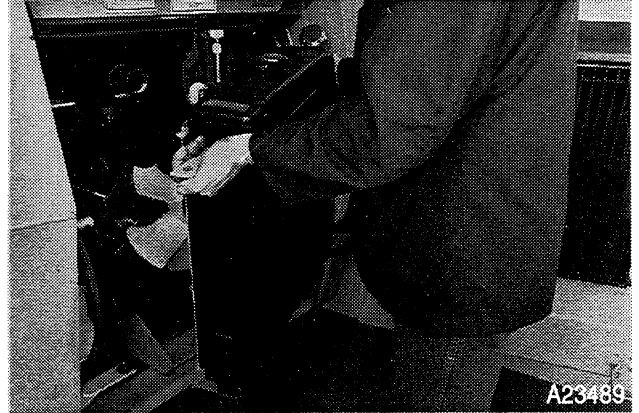
STEP 11

Remove the radiator from the machine.

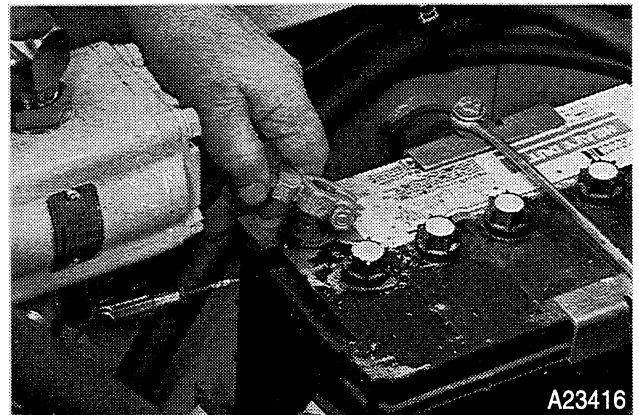
STEP 12

Disconnect the ground cable from the negative post on the battery.

STEP 13

Install the CAS-1871 adapter on the hydraulic reservoir in place of the breather cap and connect the CAS-10192.

STEP 14

Turn the CAS-10192 vacuum pump ON to hold the hydraulic fluid in the reservoir while disconnecting and plugging the hydraulic lines.

STEP 15

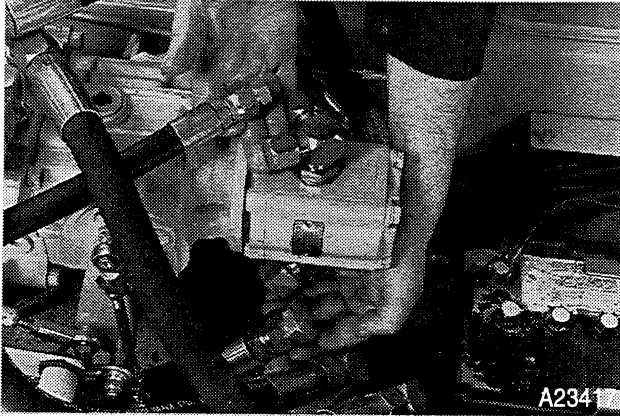

Disconnect the hoses to the inlet and outlet of the gear pump. Install plugs in the hoses and caps on the fittings.

STEP 16

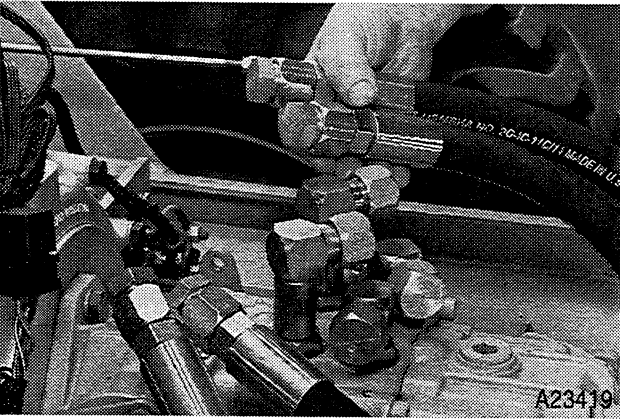

Disconnect the hoses at the work ports for the piston pumps. Install plugs in the hoses and caps on the fittings. Fasten identification tags to the hoses.

STEP 17

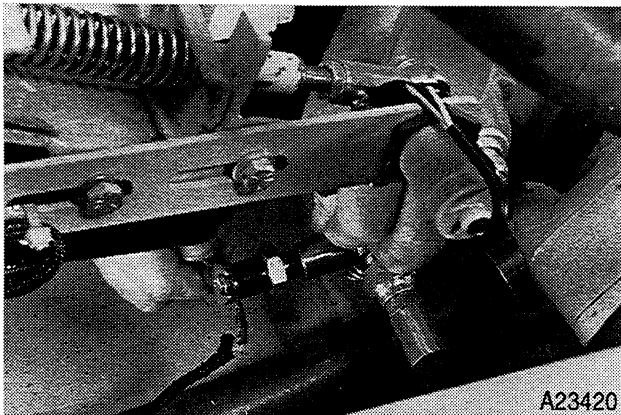

Disconnect the wire from the hydraulic oil temperature switch.

STEP 18

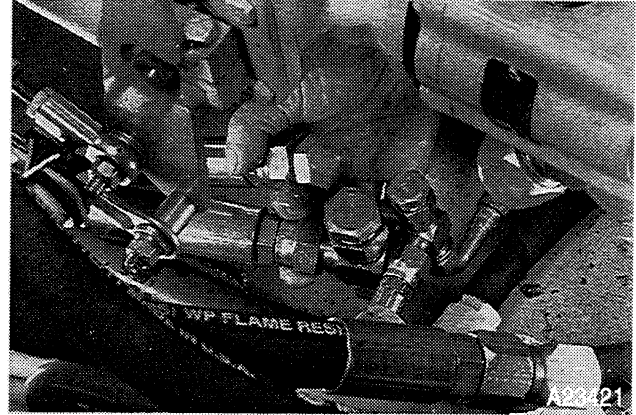

Disconnect the hoses under the piston pumps for the case drain and charge oil lines. Install plugs in the hoses and caps on the fittings.

STEP 19

Make sure all the plugs in the hoses are tight and turn the vacuum pump OFF.

STEP 20

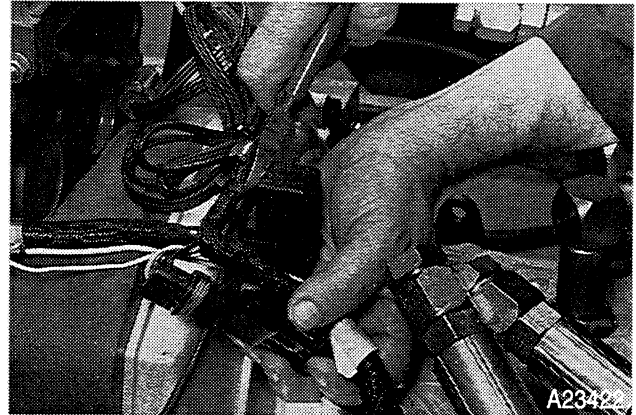

If the machine is equipped with a backup alarm, disconnect the harness connector and cut the tie strap holding the relay.

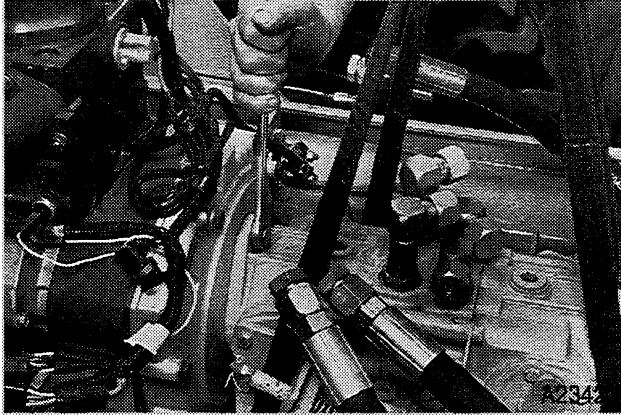
STEP 21

Fasten acceptable lifting equipment to the tandem pumps. Loosen and remove the cap screws that hold the tandem pumps.

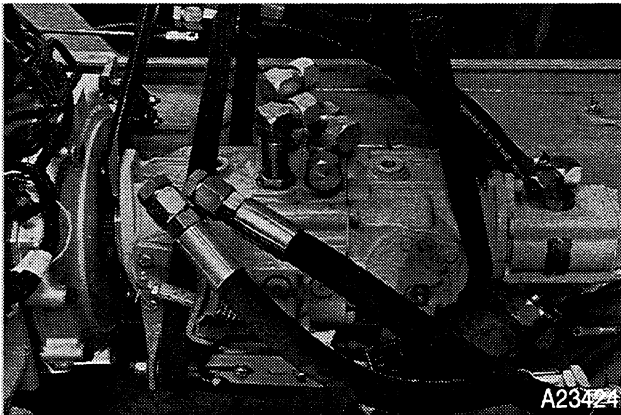
STEP 22

Use a prybar to help separate the tandem pumps from the mounting plate and drive coupling. Remove the tandem pumps.

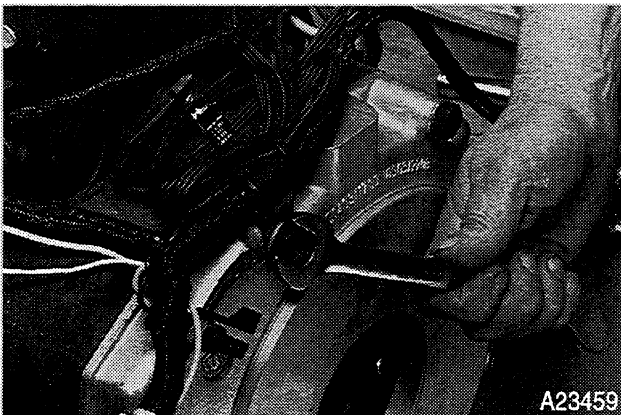
STEP 23

Loosen and remove cap screw for pump mount housing holding ground cable. Disconnect the ground cable from the engine.

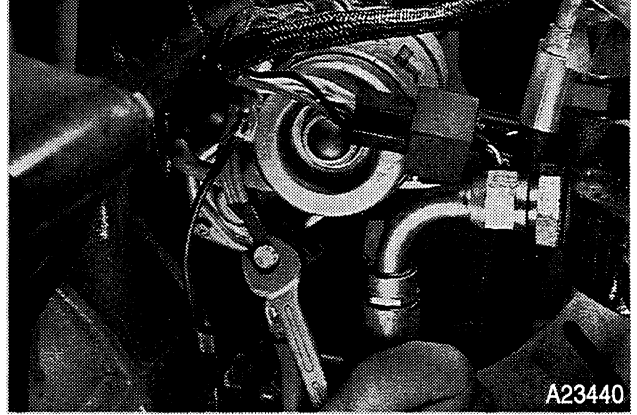
STEP 24

Disconnect the positive cable from the battery terminal on the starter.

STEP 25

Disconnect the wire from the fuel level sender.

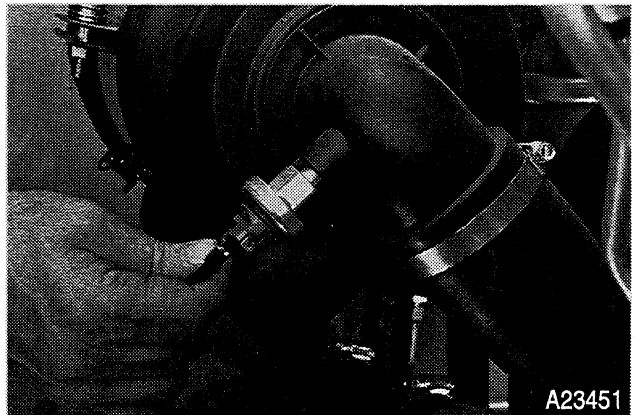
STEP 26

Disconnect the wires to the air filter condition switch.

STEP 27

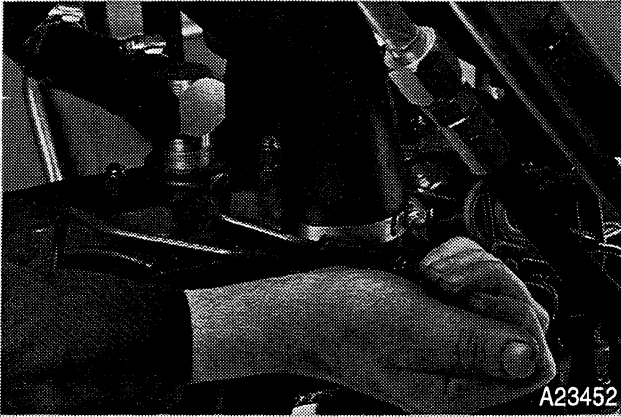

Loosen the clamp on the air cleaner hose at the intake manifold

STEP 28

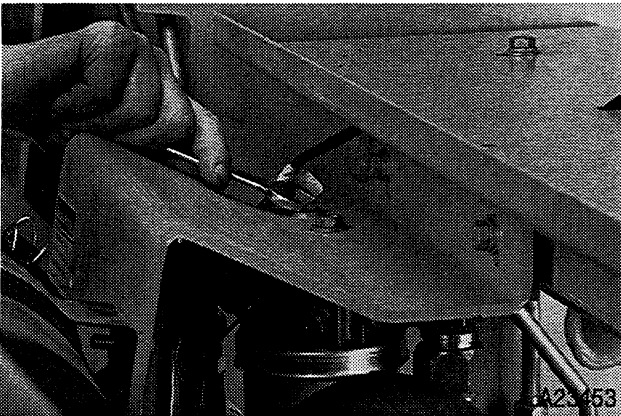

Loosen and remove the two cap screws fastening the hydraulic filter to the mounting bracket.

STEP 29

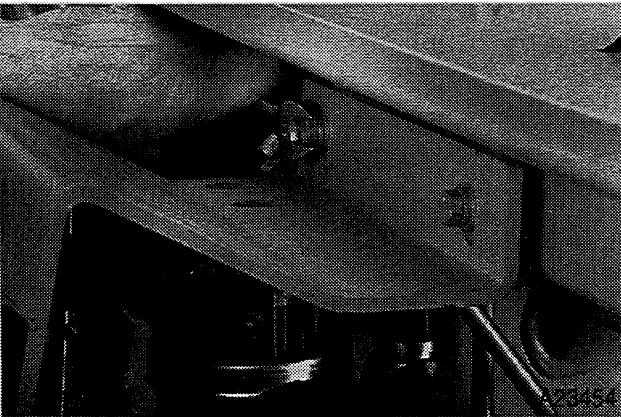

Loosen and remove the two cap screws fastening the mounting bracket to the frame. Remove the bracket and air cleaner as an assembly.

STEP 30

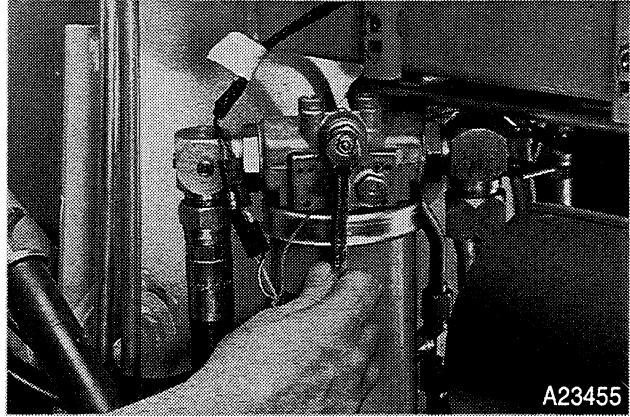

Disconnect the wire from the hydraulic oil filter. If the machine is equipped with a backup alarm, disconnect the connector for the backup alarm.

STEP 31

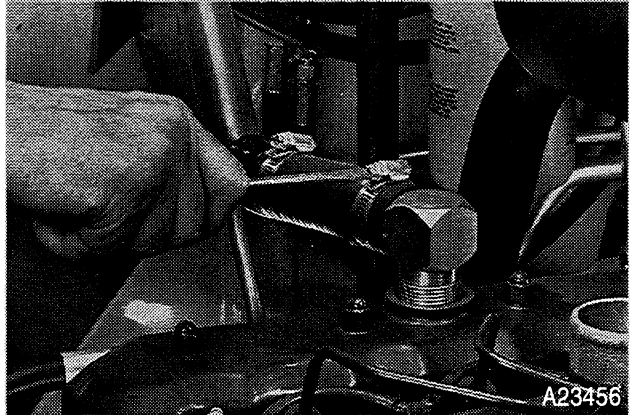

Loosen the clamp on the oil filler at the elbow in the valve cover. Remove the oil filler tube and hose.

STEP 32

Loosen and remove the four cap screws and flat washers which fasten the muffler flex coupling to the exhaust manifold.

STEP 33

Loosen and remove two cap screws and flat washers which fasten the muffler mounting bracket to the main frame. Remove the muffler and mounting bracket.

STEP 34

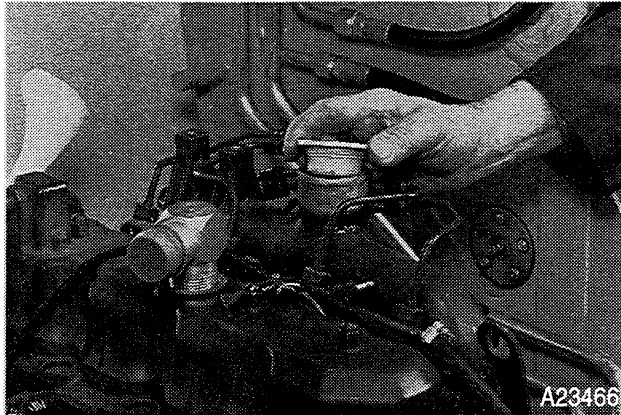

Cover or close the opening in the intake manifold and the oil filler elbow on the valve cover.

STEP 37

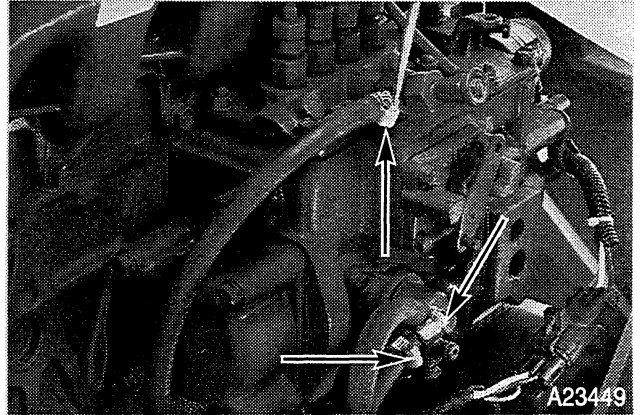

Loosen the hose clamps and remove the fuel line hoses at three places. Fasten identification tags to the hoses.

STEP 35

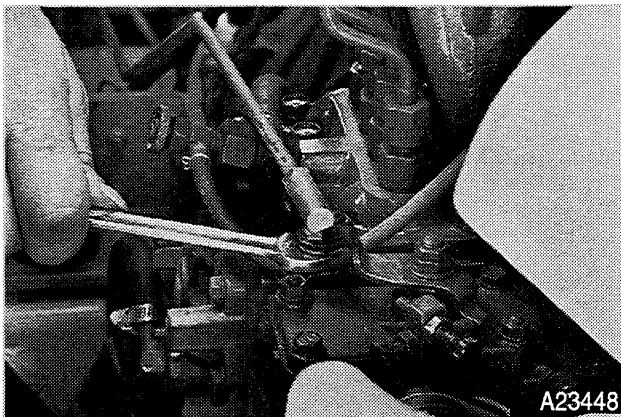

Loosen and remove the nut from the ball joint at the speed control lever for the injection pump. Remove the throttle rod.

STEP 38

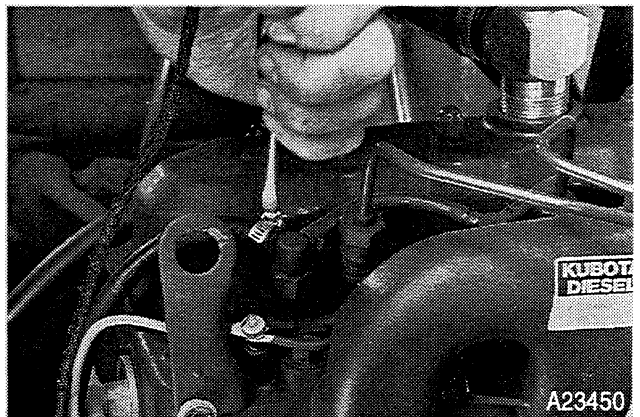

Loosen the hose clamp and remove the hose for the fuel return line. Keep the end of the hose above the level of fuel in the fuel tank to prevent leakage.

STEP 36

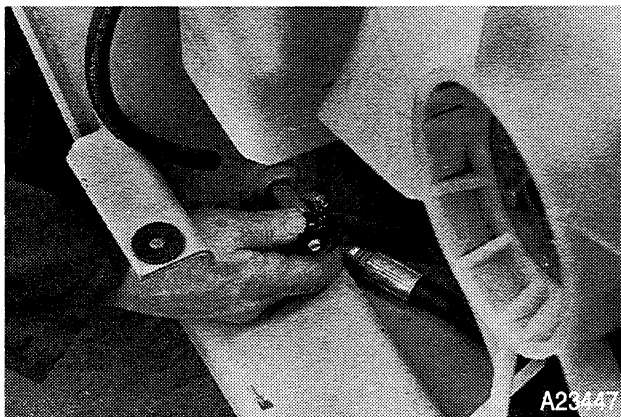

Close the shutoff valve for the fuel supply line.

STEP 39

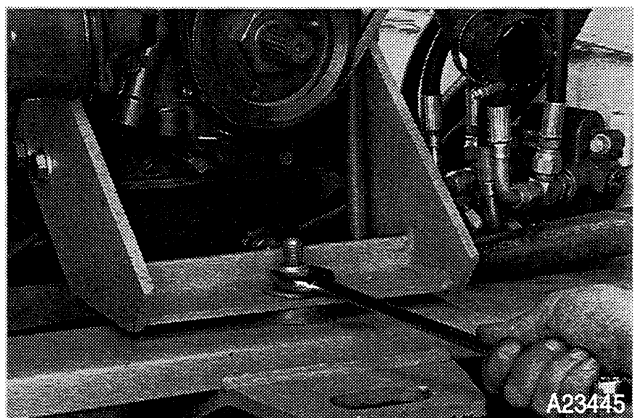

Loosen and remove the nut and cap screw for the rear engine mount.

STEP 40

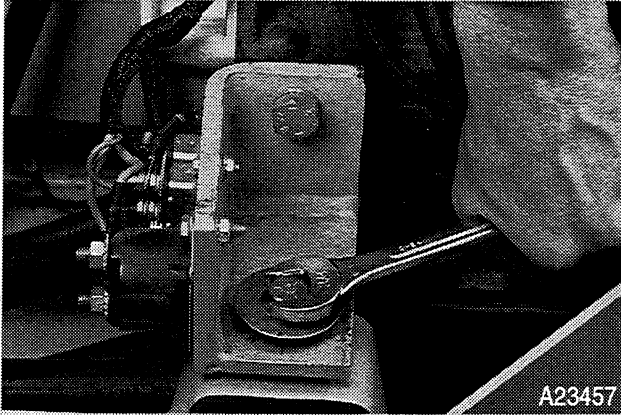

Loosen and remove the cap screw and nut for the left front engine mount.

STEP 42

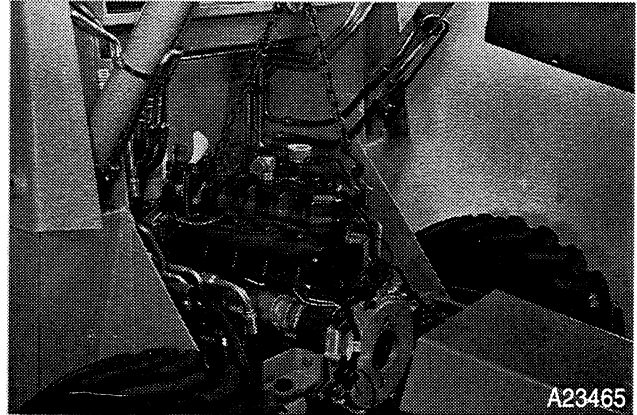

Attach a lifting sling to the lifting eyes on the engine. Remove the engine from the main frame.

STEP 41

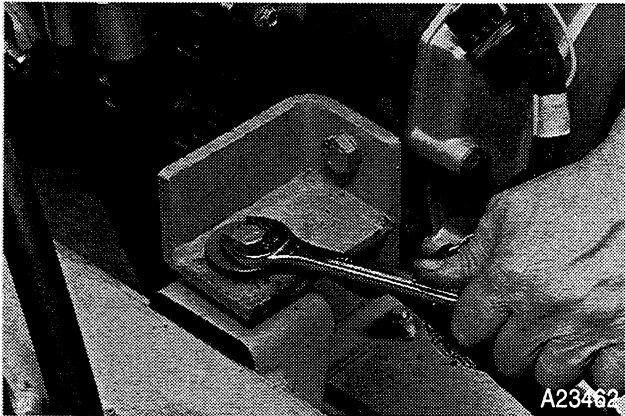

Loosen and remove the cap screw and nut for the right front engine mount.

ENGINE INSTALLATION

STEP 43

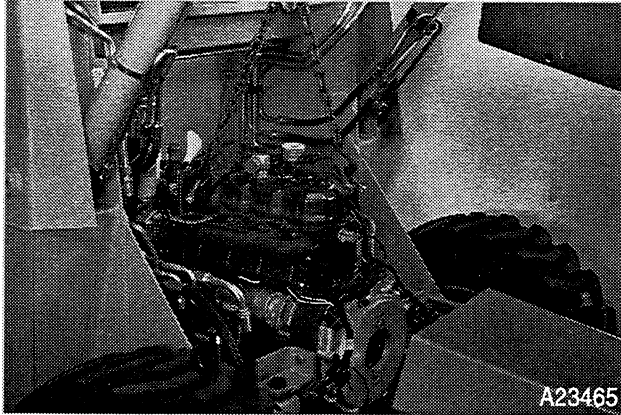

Lift the engine over the machine and lower the engine into place.

STEP 44

Install the flat washers, cap screws, lock washers and nuts finger tight for all three engine mounts.

STEP 45

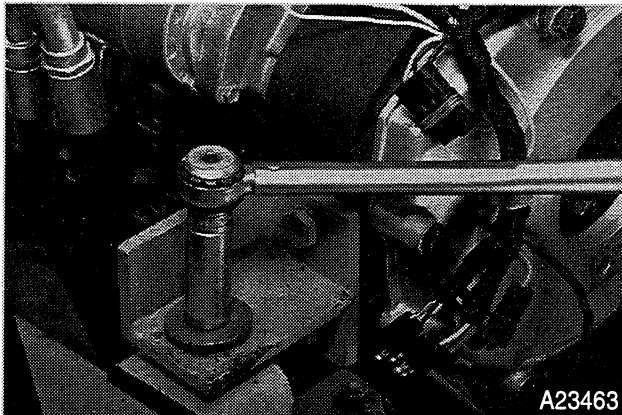

Tighten the cap screw and nut for the right front engine mount to a torque of 80 to 96 lb ft (109 to 130 Nm).

STEP 46

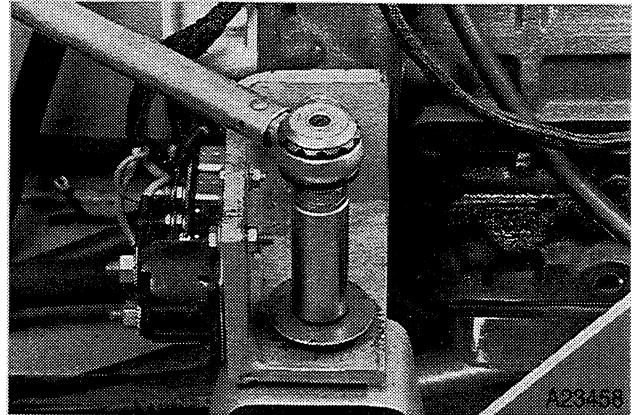

Tighten the cap screw and nut for the left front engine mount to a torque of 80 to 96 lb ft (109 to 130).

STEP 47

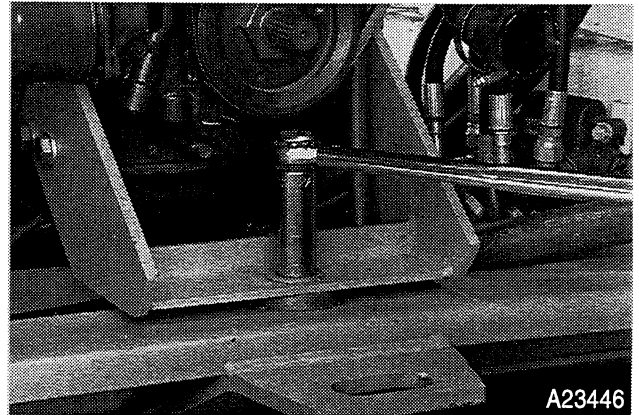

Tighten the nut and cap screw for the rear engine mount to a torque of 150 to 180 lb ft (203 to 244 Nm).

STEP 48

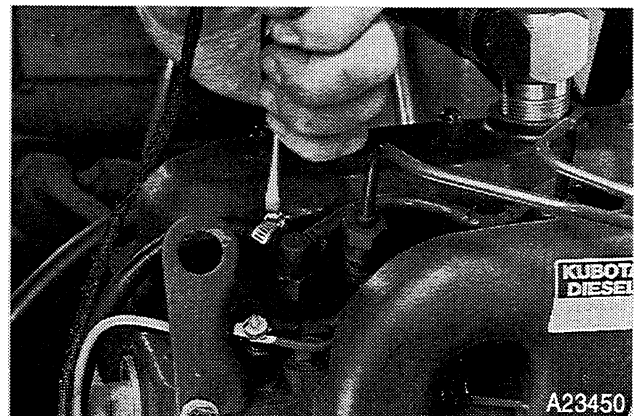

Install the hose for the fuel return line from the injectors and tighten the hose clamp.

STEP 49

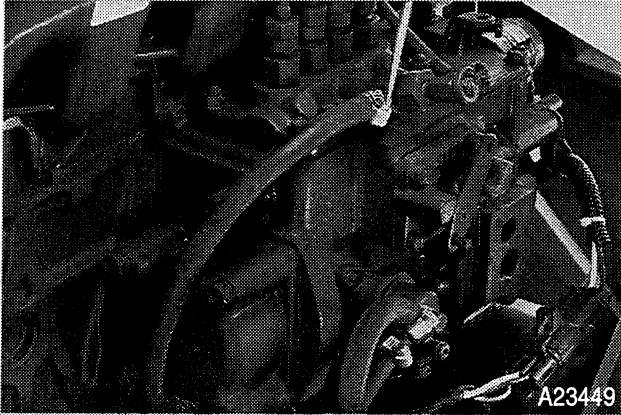

Install the hoses for the fuel lines to the transfer pump and injection pump. Tighten the hose clamps.

STEP 50

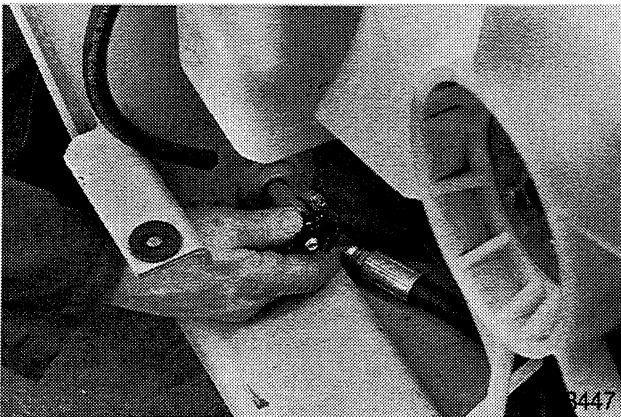

Open the shut off valve for the fuel supply line. Bleed the fuel system of air and check for leaks.

STEP 51

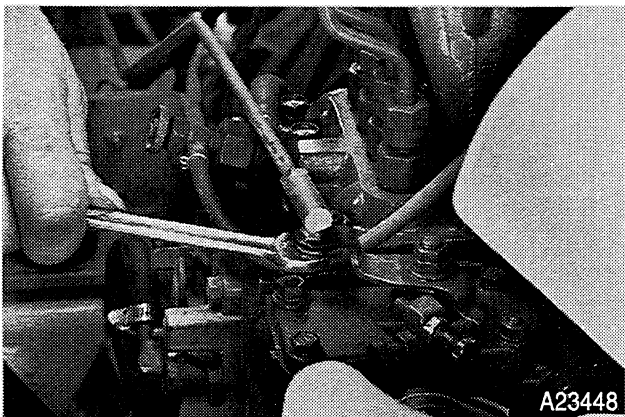

Install the ball joint for the throttle rod in the speed control lever and tighten the nut.

STEP 52

Install the two cap screws and flat washers that fastens the muffler mounting bracket to the main frame and tighten the cap screws.

STEP 53

Install the four cap screws and flat washers that fasten the flex coupling for the muffler to the exhaust manifold outlet and tighten the cap screws.

STEP 54

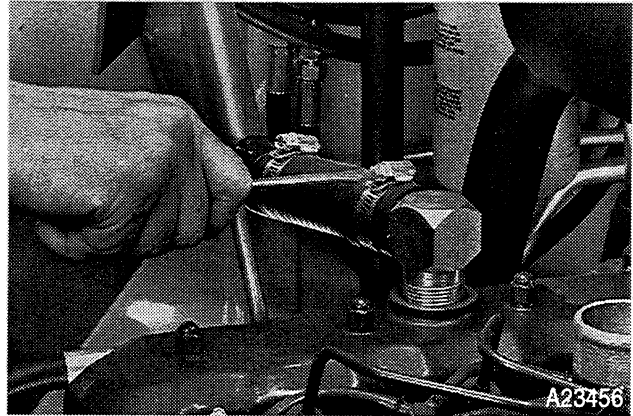

Remove protective cover from elbow and install the oil filler tube and hose on the elbow in the valve cover and tighten the hose clamp.

STEP 55

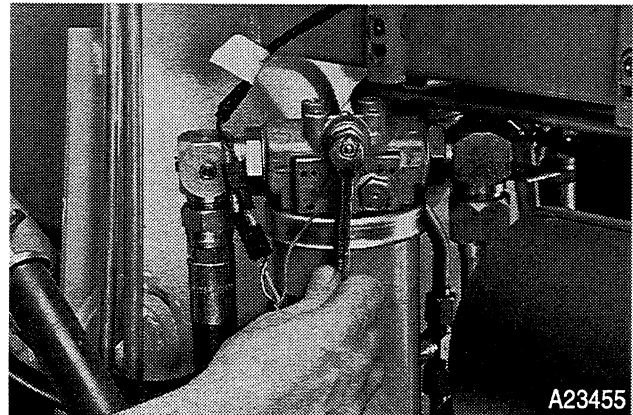

Connect the wire for the switch on the hydraulic filter. If the machine is equipped with a backup alarm connect the connector for the backup alarm.

STEP 56

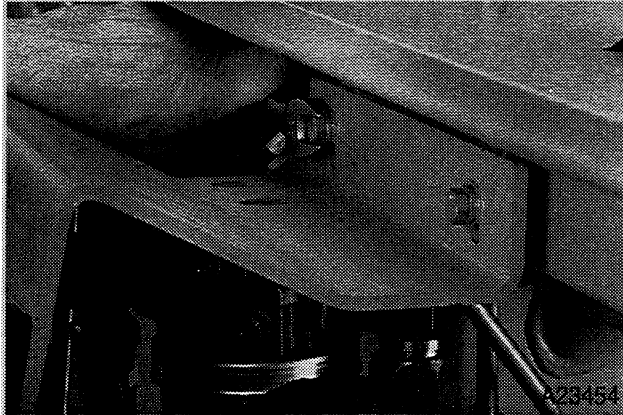

Install the two cap screws, flat washers and lock washers that fasten the mounting bracket for the air cleaner to the main frame and do not tighten the cap screws until after STEP 57.

STEP 57

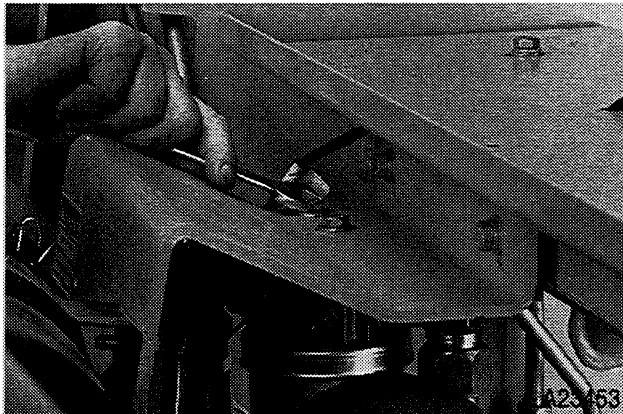

Install the two cap screws and flat washers that fasten the hydraulic filter to the mounting bracket and tighten all mounting bracket capscrews.

STEP 58

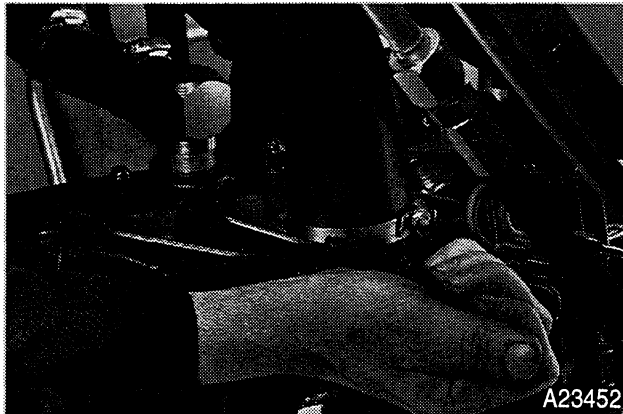

Remove protective cover from intake manifold. Install the hose from the air cleaner on the intake manifold and tighten the hose clamp.

STEP 59

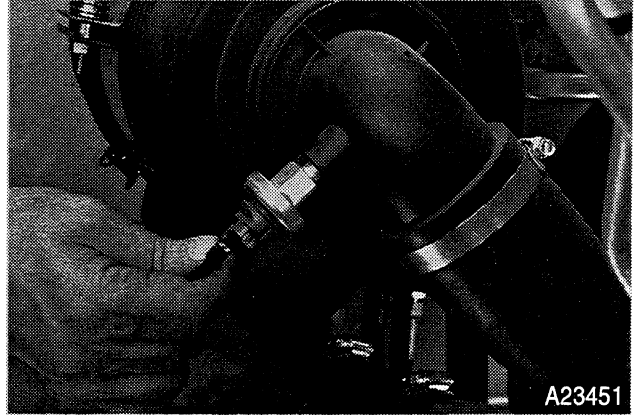

Connect the wires to the air filter condition switch.

STEP 60



Connect the wire to the fuel level sender.

STEP 61

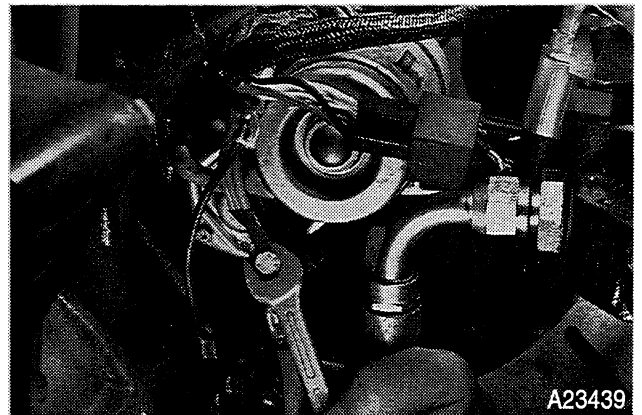

Connect the positive cable from the battery to the starter terminal and tighten the cap screw.

STEP 62

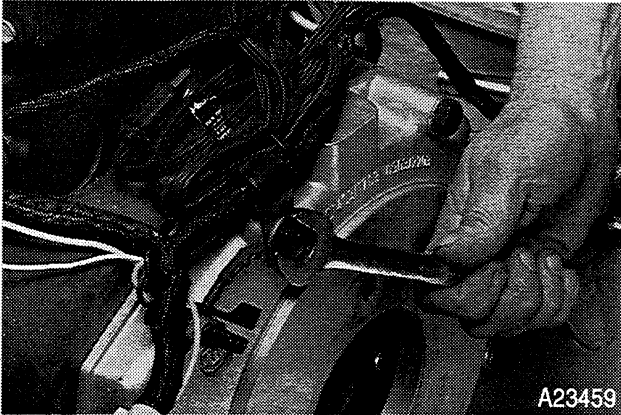

Install the grounding cable for the engine on the cap screw for the pump mount housing and tighten the cap screw.

STEP 63



Use acceptable lifting equipment to lift the tandem pumps for installing in the machine.

STEP 64

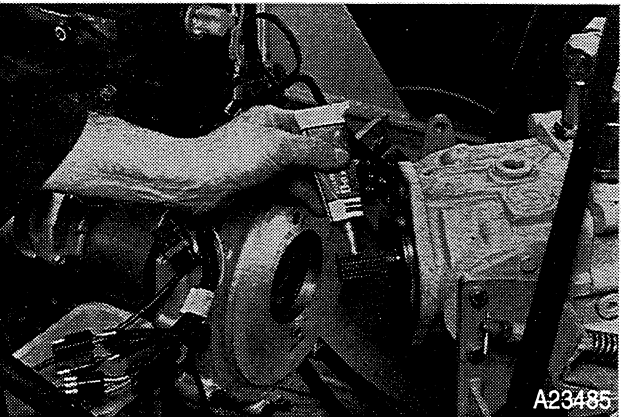

Apply MOLYKOTE G-n lubricant on the splines of the tandem pump drive shaft pinion to installation into the drive coupling.

STEP 65

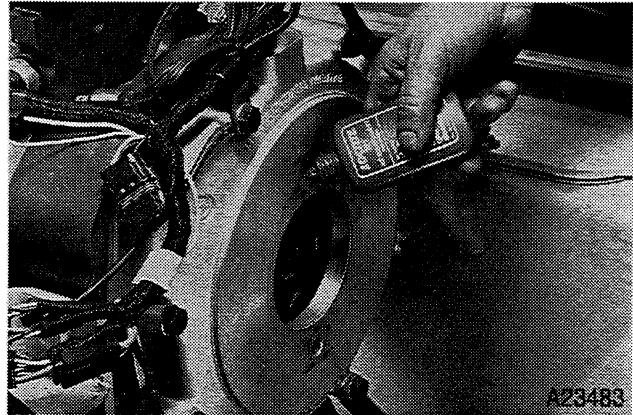

Apply 271 Loctite to the threaded holes in the pump mount housing.

STEP 66

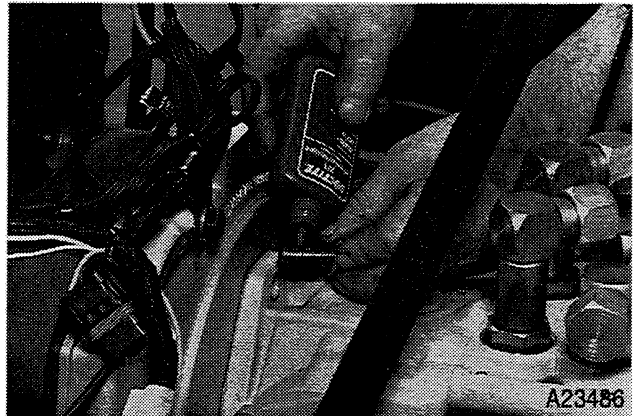

Install the tandem pump into the drive coupling and pump mount housing. Apply 271 Loctite to the treads of the cap screws before installing.

STEP 67



Install and tighten the two cap screws with lock washers that fasten the tandem pumps to the pump mounting housing. Tighten to a torque of 38 to 42 lb ft (52 to 57 Nm).

STEP 68

Install the CAS-1871 adapter on the hydraulic reservoir in place of the breather cap and connect the CAS-10192 vacuum pump.

STEP 69

Turn the CAS-10192 vacuum pump ON to hold the hydraulic fluid in the reservoir while removing the plugs and connecting the hydraulic lines.

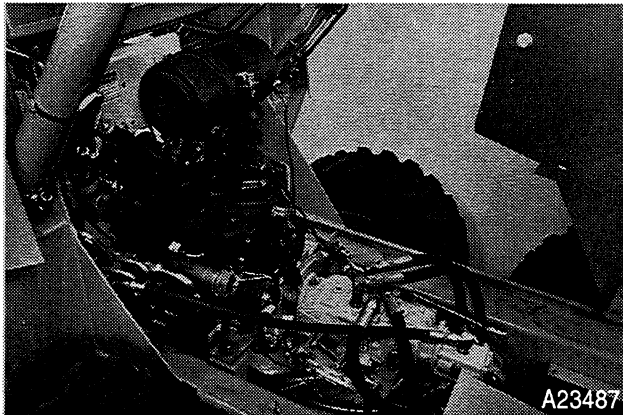
STEP 70

Remove the plugs and caps and connect the hoses to the fittings on the piston pumps and gear pump and tighten the connections.

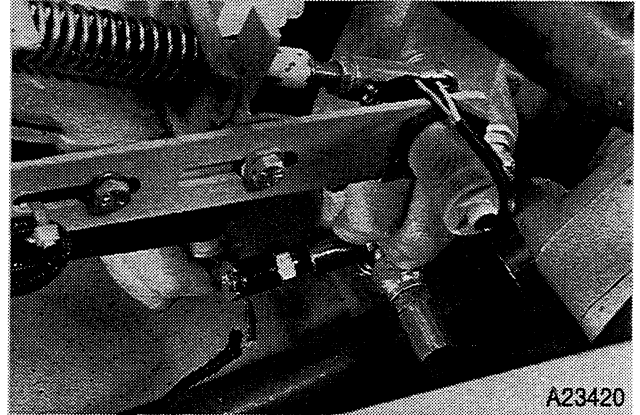
STEP 71

Connect the wire to the hydraulic oil temperature switch and tighten the nut.

STEP 72

Make sure all the hose connections are tight and turn the vacuum pump OFF. Remove the vacuum pump and CAS-1871 adapter and install the breather cap on the reservoir.

STEP 73

If the machine is equipped with a back up alarm connect the connector for the proximity switches and install a new tie strap to fasten the relay switch to the wire harness on the top of the engine bell housing.

STEP 74

Connect the ground cable to the negative post on the battery and tighten the clamp.

STEP 75

Fasten the operators compartment in the operating position according to the instructions in Section 9003.

STEP 76

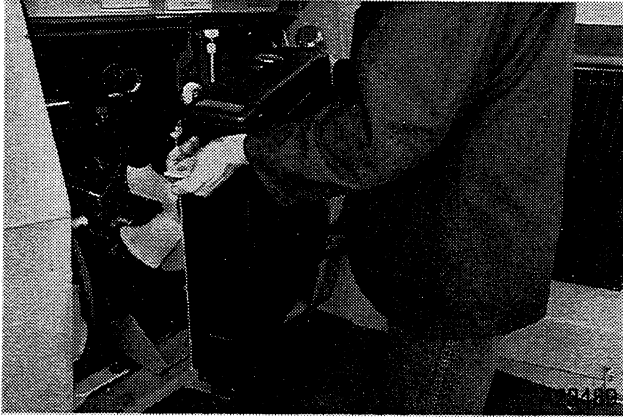

Install the radiator on the mounting brackets.

STEP 77

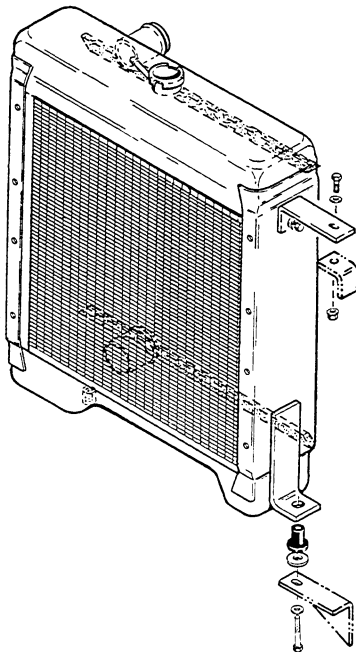
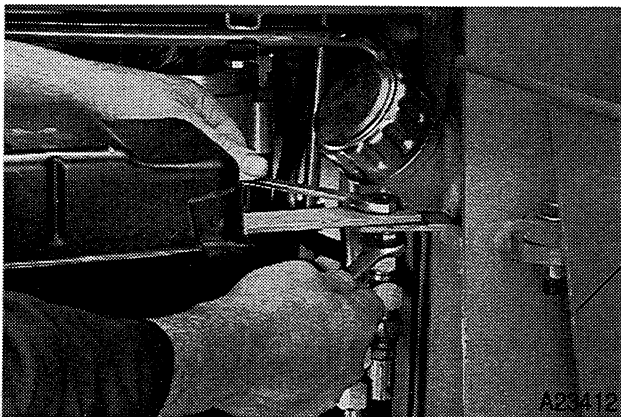

B890766J

Install the hardware for the right side of the radiator as shown. Tighten the bottom cap screw to 15 to 20 lb inches (1.68 to 2.25 Nm).

STEP 78

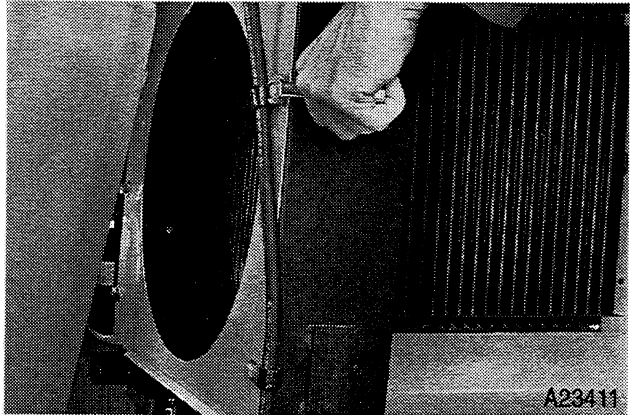

Install the clamps for the coolant reservoir hose and install the cap screws and flat washers. Tighten the cap screws.

STEP 79



Push the left side of the radiator to the front. Install the cap screw and flat washers that fasten the left side of the radiator to the left radiator mounting bracket. Tighten the cap screw to 15 to 20 lb inches (1.68 to 2.25 Nm).

STEP 80

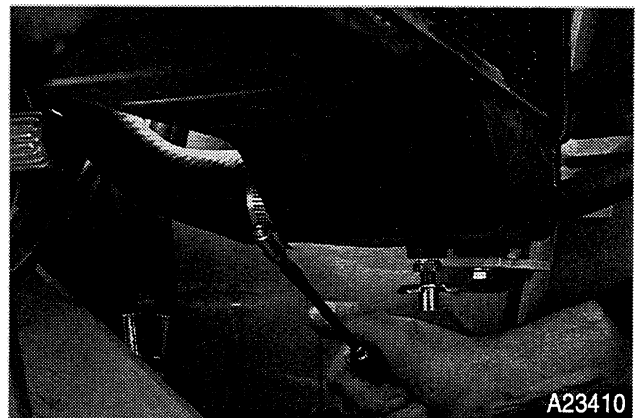

Connect the bottom radiator hose and tighten the clamp.

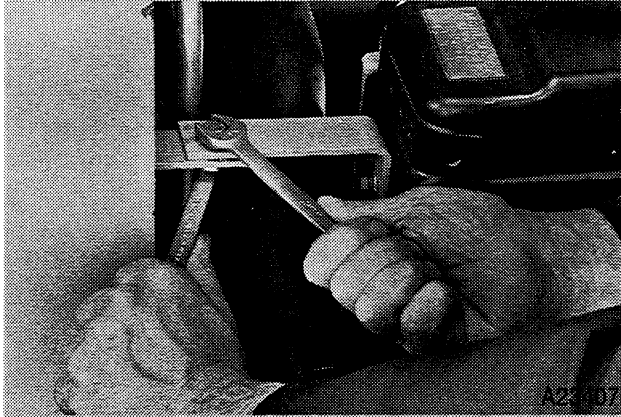
STEP 81

Install the bolt, flat washer and self-locking nut that fasten the top left radiator support to the frame. Tighten the self-locking nut.

NOTE: *Make sure the fan is centered in the fan shroud. Loosen radiator mounting hardware and move radiator as required.*

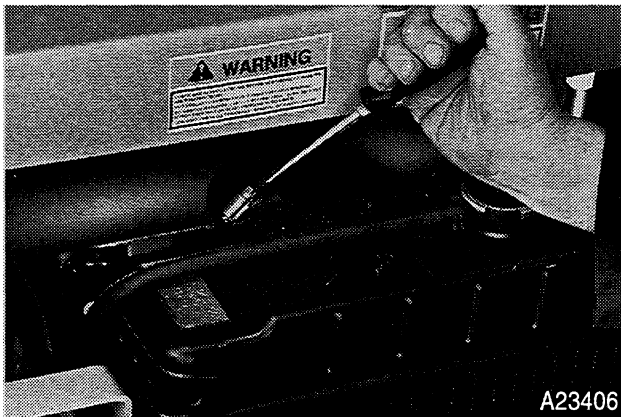
STEP 82

Connect the hose for the coolant reservoir to the radiator. Connect the top radiator hose and tighten the clamp.

STEP 83

Close the drain valve in the radiator and fill the radiator with coolant. See Section 1002 for coolant specifications.

STEP 84

Install the radiator cap.

STEP 85

Fill the coolant reservoir to the FULL mark.

STEP 86

Make sure that the crankcase has been filled with engine oil. See Section 1002.

STEP 87

Do the Hydrostatic Start-Up procedure. See page 6001-16.

STEP 88

Start the engine and run the engine at idle until the engine is at operating temperature. If necessary see Section 3410 to bleed air from the fuel system. Check for coolant and fuel leaks.

STEP 89

Stop the engine.

STEP 90

Check the level of the coolant in the coolant reservoir and add coolant as required.

2001-18

STEP 91

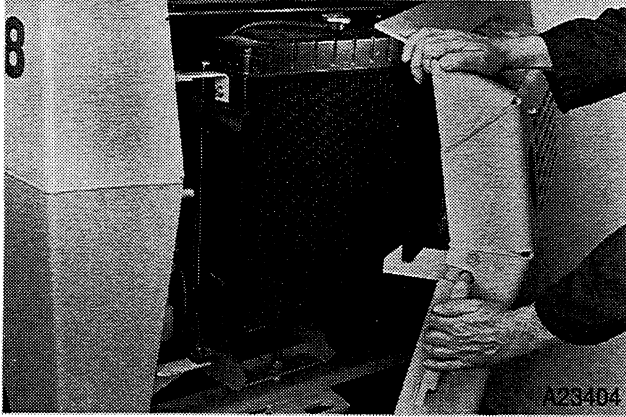

Close the rear door.



Suggest:

If the above button click is invalid.

Please download this document

first, and then click the above link

to download the complete manual.

Thank you so much for reading

RADIATOR REMOVAL

STEP 92

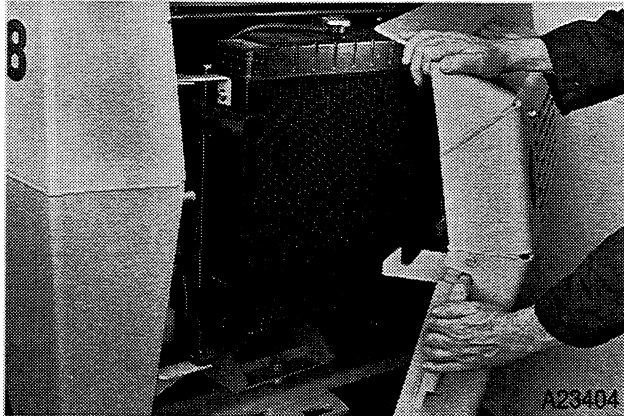

Open the rear door.

STEP 93

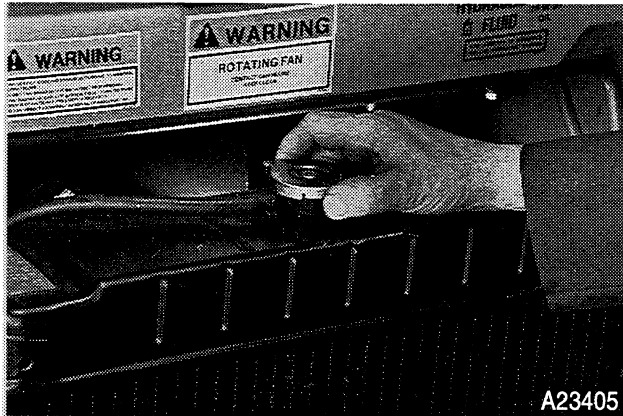

Remove the radiator cap.

STEP 94

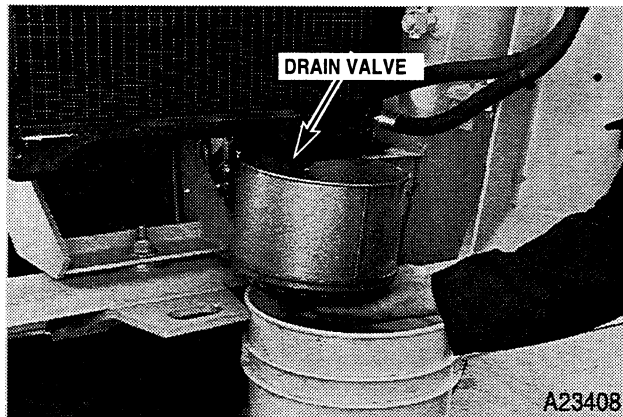

Open the drain valve and drain the cooling system. The cooling system capacity is approximately 12 U.S. quarts (11.3 litres) of coolant.

STEP 95



Loosen the clamp and disconnect the top hose from the radiator. Disconnect the hose for the coolant reservoir from the radiator. Install a plug in the coolant reservoir hose.

STEP 96

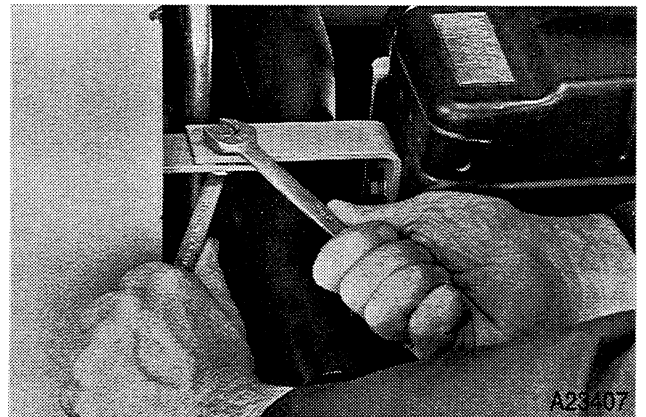

Loosen and remove the self-locking nut, flat washer and bolt that fasten the top left radiator support to the frame.

STEP 97

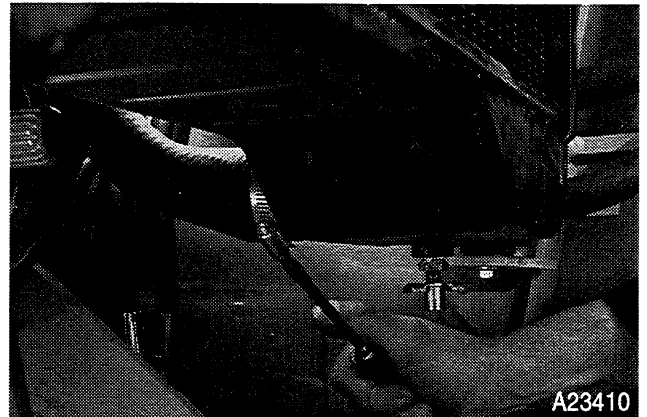

Loosen the clamp and disconnect the bottom hose from the radiator.

<https://www.ebooklibonline.com>

Hello dear friend!

Thank you very much for reading.

Enter the link into your browser.

The full manual is available for immediate download.

<https://www.ebooklibonline.com>