

1835 UNI-LOADER TABLE OF CONTENTS AND SERVICE MANUAL INTRODUCTION

Table of Contents

SERIES/SECTION	SECTION NO.	FORM NO.
10 SERIES - GENERAL		
General Engine Specifications -		
188D Diesel	1010	8-22720
Decals and Painting	1012	9-68700
Detailed Engine Specifications - 188D Diesel	1027	9-78675
Maintenance and Lubrication	1050	9-68700
Torque Charts	1051	9-68700
Noise Control	1052	9-68700
General Engine Specifications - 148G Spark Ignition	1110	8-22790
Detailed Engine Specifications - 148G Spark Ignition	1129	9-79086
20 SERIES - ENGINE		
Engine Diagnosis	2001	9-78875
Engine Tune-Up - 188D Diesel	2002	9-78825
Cylinder Head, Valve Train and Camshaft - 188D Diesel	2015	9-78836
Cylinder Block, Sleeves, Pistons and Rods - 188D Diesel	2025	9-78855
Crankshaft, Bearings, Flywheel and Oil Seals - 188D Diesel	2035	9-78866
Oil Pump - 188D Diesel	2045	9-78885
General Engine Information	2050	9-68700
Air Cleaner and Muffler	2051	9-68700
Ether Injection	2053	9-68700
Cooling System - 188D Diesel	2055	9-78816
Engine Tune-Up - 148G Spark Ignition	2102	8-22800
Cylinder Head, Valve Train and Camshaft - 148G Spark Ignition	2115	8-22810
Cylinder Block, Sleeves, Pistons and Rods - 148G Spark Ignition	2125	8-22820
Crankshaft, Bearings, Flywheel and Oil Seals - 148G		
Spark Ignition	2135	8-22830
Oil Pump - 148G Spark Ignition	2145	8-22840
Cooling System - 148G Spark Ignition	2155	8-22850
Engine Lubrication - 188D Diesel	2555	9-78985
30 SERIES - FUEL SYSTEM		
Fuel Filters - 188D Diesel	3010	8-22770
Fuel Injection Pump	3012	9-78795
Fuel Injectors	3013	9-78806
Engine Controls, Fuel Lines, and Fuel Tank	3052	9-68700
Carburetor	3112	8-22870
40 SERIES - ELECTRICAL SYSTEM		
Electrical System Specifications and Troubleshooting	4002	9-68700
Wiring Diagram	4003	9-68700
Gauges	4004	9-68700
Battery	4005	9-68700
Starter and Solenoid	4006	9-68700
Alternator	4007	9-68700
Spark Ignition System	4008	9-68700
Electrical Accessories	4015	9-68700

SERIES/SECTION	SECTION NO.	FORM NO.
60 SERIES - POWER TRAIN		
Hydrostatic Troubleshooting, Testing, and Adjustments	6302	9-68700
Hydrostatic System Diagrams and Operation	6304	9-68700
Piston Pumps	6305	9-68700
Hydrostatic Motor	6312	9-68700
Hydrostatic Controls	6318	9-68700
Drive Sprockets and Chains	6515	9-68700
Drive Axles and Hubs	6527	9-68700
Wheels and Tires	6529	9-68700
70 SERIES - BRAKES		
Parking Latch	7124	9-68700
80 SERIES - HYDRAULIC SYSTEM		
Hydraulic Diagrams, Maintenance and Troubleshooting	8002	9-68700
Dual Gear Pump	8005	9-68700
Equipment Control Valve	8007	9-68700
Auxiliary Control Valve	8031	9-68700
Cylinders	8090	9-68700
90 SERIES - MOUNTED EQUIPMENT		
Loader	9010	9-68700
Auxiliary Hydraulic Installations	9012	9-68700
ROPS Canopy	9061	9-68700

Section 1010

GENERAL ENGINE SPECIFICATIONS

1835 UNI-LOADER (188 Diesel Engine)

Written In *Clear
And
Simple
English*

<https://www.ebooklibonline.com>

Hello dear friend!

Thank you very much for reading.

Enter the link into your browser.

The full manual is available for immediate download.

<https://www.ebooklibonline.com>

188 DIESEL ENGINES

General

Type	Case Open Chamber, 4 Cylinder, 4 Stroke Cycle, Valve-in-Head
Firing Order	1-3-4-2
Bore	3-13/16 Inches (96.8 mm)
Stroke	4-1/8 Inches (104.8 mm)
Piston Displacement	188 Cubic Inches (3 081 cm ³)
Compression Ratio	17 to 1
No Load Governed Speed	2250 RPM
Rated Engine Speed	2100 RPM
Engine Idling Speed	800 to 850 RPM
Valve Tappet Clearance (Exhaust)	(Cold) 0.014 Inch (0.356 mm)
(Intake)	(Cold) 0.012 Inch (0.305 mm)

Piston and Connecting Rods

Rings per Piston	3
Number of Compression Rings	2
Number of Oil Rings	1
Type Pins	Full Floating Type
Type Bearing	Replaceable Precision, Steel Back, Copper-Lead Alloy Liners

Main Bearings

Number of Bearings	5
Type Bearings	Replaceable Precision, Steel Back, Copper-Lead Alloy Liners

Engine Lubricating System

Crankcase Capacity	6 Quarts (5.7 litres)
With Filter Change	7 Quarts (6.7 litres)
Oil Pressure	50 to 70 PSI (345 to 483 kPa)(3.45 to 4.83 bar) with Engine Warm and Operating at Rated Engine Speed
Type System	Pressure and Spray Circulation
Oil Pump	Gear Type
Oil Filter	Full Flow Spin on Type

Fuel System

Fuel Injection Pump	Roosa-Master
Pump Timing	4 Degrees Before Top Center
Fuel Injectors	Pencil Type Opening Pressure 3200 PSI (22 063 kPa)
Fuel Transfer Pump	Vane Type, Integral Part of Injection Pump
Governor	Variable Speed, Fly-Weight Centrifugal Type, Integral Part of Injection Pump
1st Stage Fuel Filter	Spin on Type
2nd Stage Fuel Filter	Spin on Type

NOTE: The CASE CORPORATION reserves the right to make improvements in design or changes in specifications at any time without incurring any obligation to install them on units previously sold.

Section 1012

DECALS

Written In *Clear
And
Simple
English*

GENERAL INFORMATION

1. All decals about the operation of the machine must be in a condition so that you can read the decals easily. Replace any decal that is damaged or cannot be read.
2. All decals that start with the words WARNING, CAUTION, or DANGER must be in a condition so that you can read the decals easily. Replace any decal that is damaged or cannot be read.
3. When you paint the machine or attachment, put covers over the good decals and remove the decals which have damage or cannot be read easily. Use enamel thinner to make the decal easier to remove.
4. Remove the old decal before you install a new decal. Use enamel thinner to make the old decal easier to remove.
5. The following pages show decals installed on the machine or attachments. Part numbers of the decals are also shown. When replacement decals are needed, check the parts catalog to make sure that the part numbers are correct.

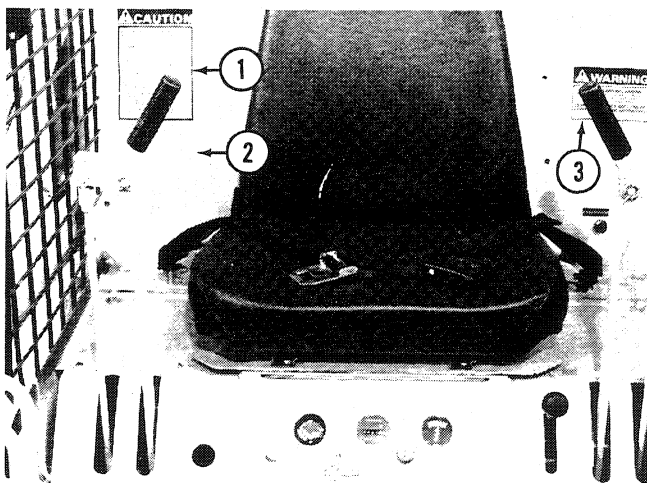

1. 321-3059, See Figure 2
2. 321-2996, See Figure 3
3. 321-3705, See Figure 4

Figure 1

CAUTION

REVIEW OPERATORS MANUAL BEFORE OPERATING THIS MACHINE

ALWAYS:

- 1 FASTEN SEAT BELT SECURELY BEFORE STARTING ENGINE
- 2 KEEP BOTH HANDS ON CONTROLS AT ALL TIMES WHILE OPERATING VEHICLE
- 3 CARRY LOAD LOW
- 4 USE LOW SPEED FOR HILLSIDE OR RAMP OPERATION
- 5 BLOCK ELEVATED COMPONENTS BEFORE SERVICING EQUIPMENT

NEVER:

- 1 LEAVE MACHINE WITH LOADER ARMS RAISED
- 2 PLACE ANY PART OF OPERATORS BODY UNDER LOADER ARMS OR ATTACHMENTS
- 3 ALLOW RIDERS
- 4 LEAVE MACHINE WHILE ENGINE IS RUNNING
- 5 LEAVE MACHINE WITHOUT SETTING PARKING BRAKE

①

800626

1 321-3059, SEE FIGURE 1 FOR LOCATION

Figure 2

POISON / DANGER

BATTERY ACID CAUSES SEVERE BURNS

Batteries contain sulfuric acid. Avoid contact with skin, eyes or clothing. Antidote: EXTERNAL-Flush with water. INTERNAL-Drink large quantities of water or milk. Follow with milk of magnesia, beaten egg or veg. oil. Call physician immediately. Eyes: Flush with water for 15 minutes and get prompt medical attention.

BATTERIES PRODUCE EXPLOSIVE GASES.

Keep sparks, flame, and cigarettes away. Ventilate when charging or using in enclosed space. Always shield eyes when working near batteries.

KEEP OUT OF REACH OF CHILDREN

①

800627

1 321-2996, SEE FIGURE 1 FOR LOCATION

Figure 3

WARNING

BEFORE STARTING ENGINE STUDY OPERATOR'S MANUAL SAFETY MESSAGES READ ALL SAFETY SIGNS ON MACHINE CLEAR THE AREA OF OTHER PERSONS

LEARN & PRACTICE SAFE USE OF CONTROLS BEFORE OPERATING

IT IS YOUR RESPONSIBILITY TO UNDERSTAND AND FOLLOW MANUFACTURER'S INSTRUCTIONS ON MACHINE OPERATION, SERVICE, AND TO OBSERVE PERTINENT LAWS AND REGULATIONS. OPERATOR AND SERVICE MANUALS MAY BE OBTAINED FROM YOUR EQUIPMENT DEALER.

①

321-3705
800628

1 321-3705, SEE FIGURE 1 FOR LOCATION

Figure 4

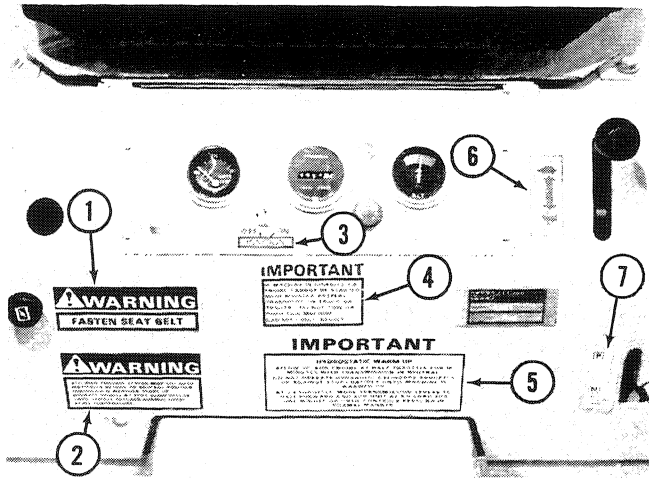

- 1. 321-3060
- 2. 321-3062 - steering control levers
- 3. 321-2507 - ignition
- 4. 321-3385 - disabled machine
- 5. 321-4197 - hydrostatic warm-up
- 6. 321-5847 - throttle
- 7. 321-5848 - parking latch

Figure 5

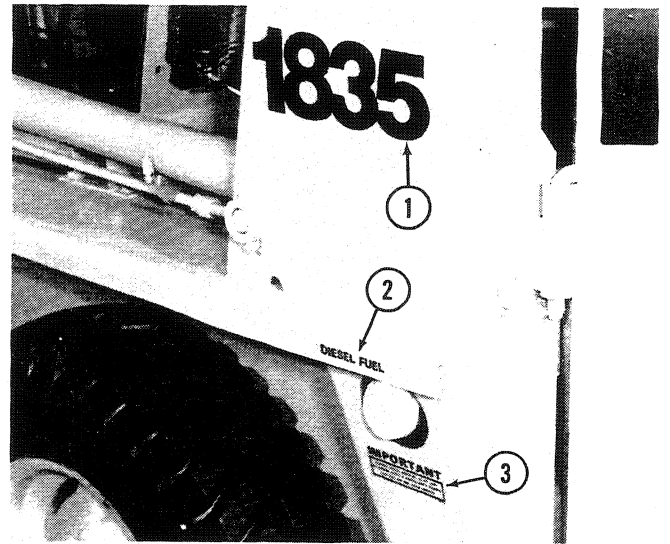

- 1. 321-5835
- 2. 321-230 Diesel, 321-18 Gasoline
- 3. 321-2973 - torque wheel nuts

Figure 8

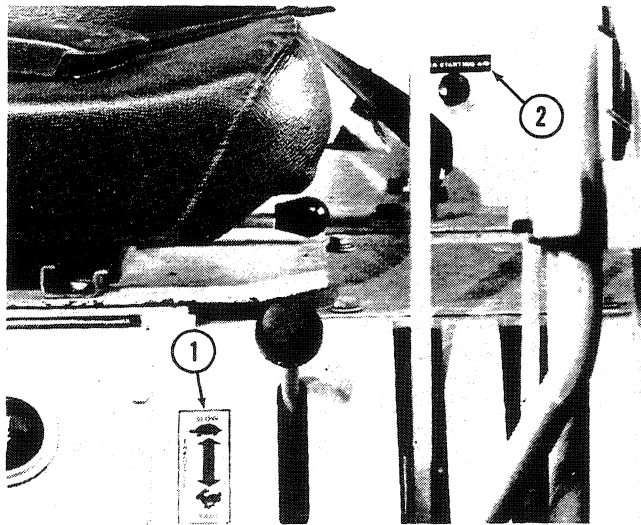

- 1. 321-5847
- 2. 321-2435, See Figure 7.

Figure 6

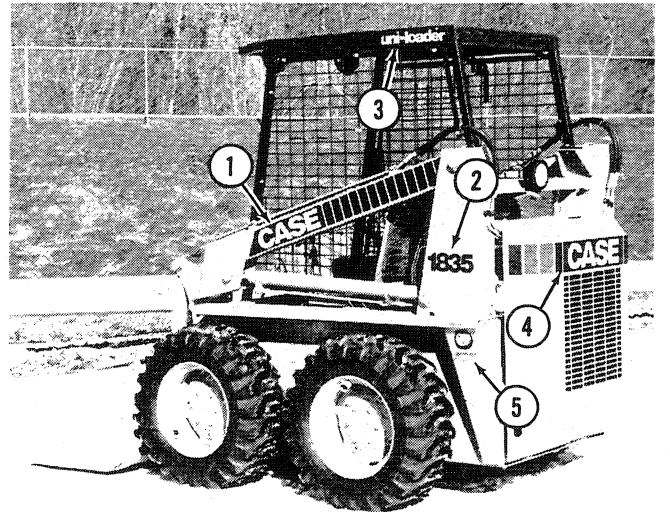

- 1. 321-5113
- 2. 321-5835
- 3. 321-3150
- 4. 321-5846
- 5. 321-2973, See Figure 8.

Figure 9

ETHER STARTING AID

1

- 1. 321-2435, SEE FIGURE 6 FOR LOCATION

800629

Figure 7

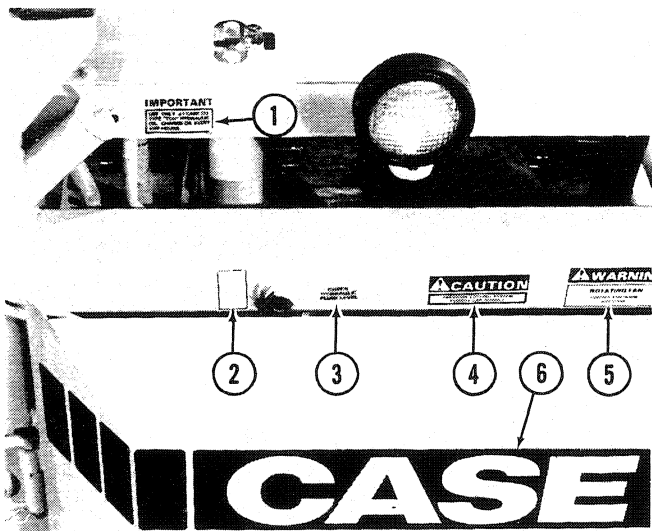

- 1. 321-3386 - TCH hydraulic oil
- 2. 321-1061, See Figure 11
- 3. 321-2733, See Figure 12
- 4. 321-3061, See Figure 13
- 5. 321-4346, See Figure 14
- 6. 321-5846

Figure 10

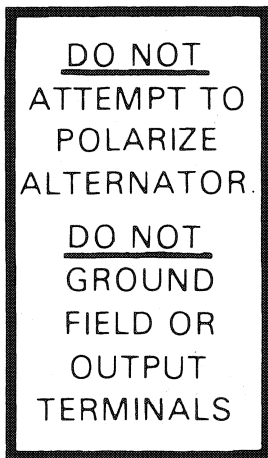

800630

- 1. 321-1061, SEE FIGURE 10 FOR LOCATION

Figure 11

CHECK HYDRAULIC FLUID LEVEL

800631

- 1. 321-2733, SEE FIGURE 10 FOR LOCATION

Figure 12

IMPORTANT

USE ONLY J I CASE CO. TYPE "TCH" HYDRAULIC OIL. CHANGE OIL EVERY 1000 HOURS

①

- 1. 321-3386, SEE FIGURE 10 FOR LOCATION
Figure 12A

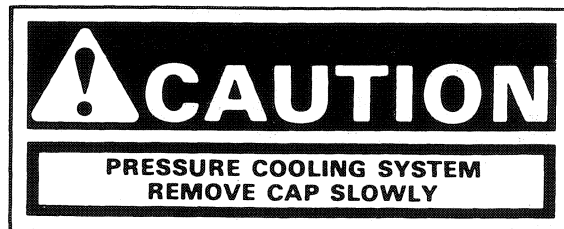

800632

- 1. 321-3061, SEE FIGURE 10 FOR LOCATION

Figure 13



800633

- 1. 321-4346, SEE FIGURE 10 FOR LOCATION

Figure 14

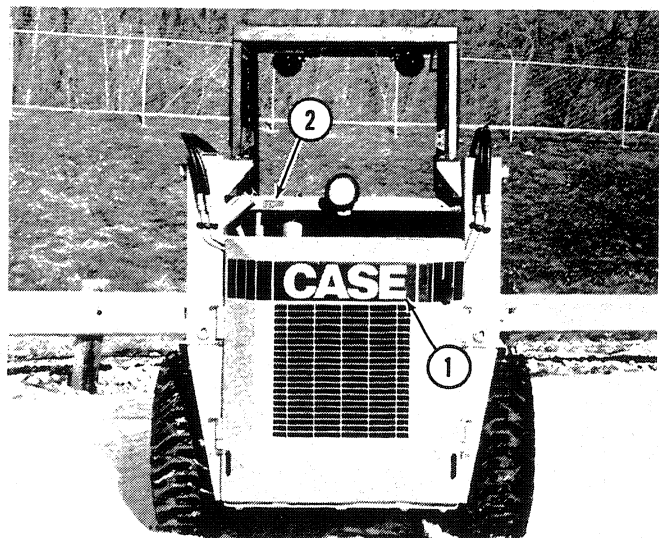

- 1. 321-5846
- 2. 321-3386, See Figure 10

Figure 15

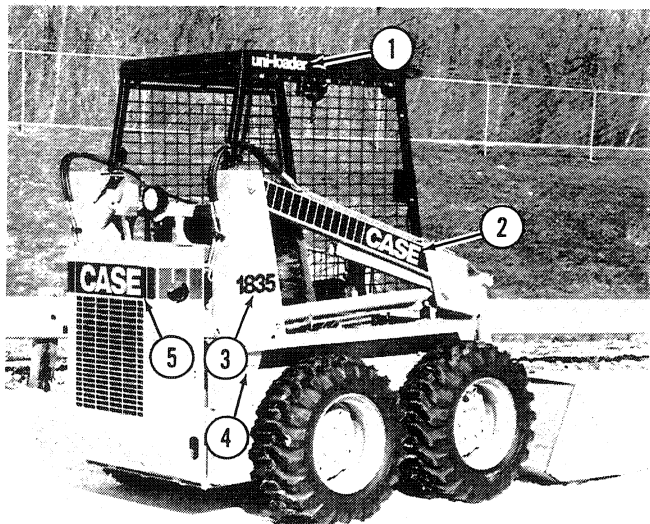

- 1. 321-3150
- 2. 321-5112
- 3. 321-5835
- 4. 321-2973, See Figure 17
- 5. 321-5846

Figure 16

IMPORTANT

**TORQUE WHEEL NUTS 80-90 FT. LBS.
RETORQUE EVERY 2 HOURS UNTIL STABLE.
CAUTION: DO NOT OVER TORQUE**

800634

- 1 321-2973, SEE FIGURE 16 FOR LOCATION

Figure 17

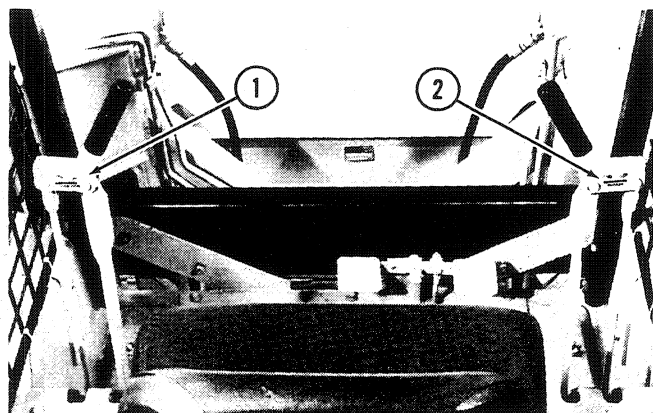

- 1. 321-5849, See Figure 19
- 2. 321-5850, See Figure 20

Figure 18

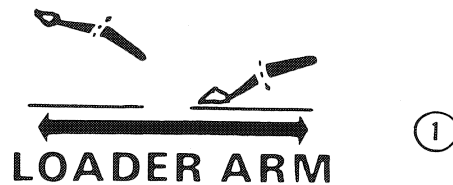

LOADER ARM

800635

- 1. 321-5849, SEE FIGURE 18 FOR LOCATION

Figure 19



BUCKET

800636

- 1 321-5850, SEE FIGURE 18 FOR LOCATION

Figure 20

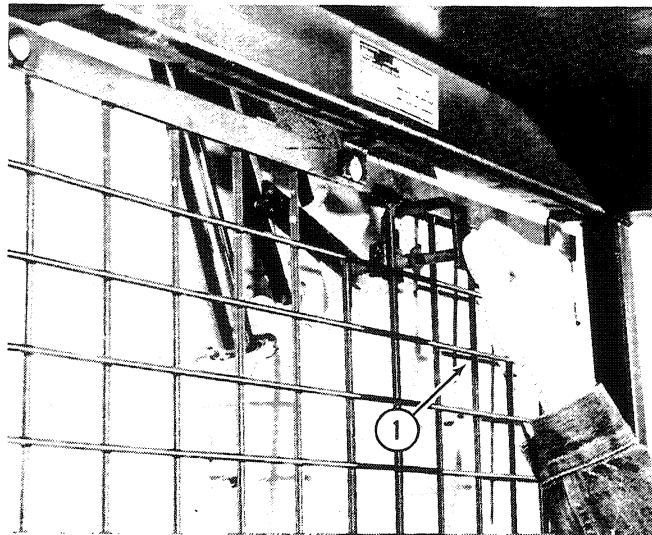

- 1. 321-6214, See Figure 22
- Figure 21

<p>WARNING</p> <p>IF YOU SERVICE THE MACHINE WITH THE LOADER LIFT ARMS RAISED ALWAYS USE THE SAFETY STRUT FAILURE TO FOLLOW THIS PROCEDURE CAN CAUSE SERIOUS INJURY OR DEATH IF THE LOADER LIFT ARMS ARE LOWERED BY ACCIDENT</p>	<p>PROCEDURE TO USE THE SAFETY STRUT</p> <ol style="list-style-type: none"> 1 MAKE SURE THE LOADER BUCKET IS EMPTY. LOWER THE LOADER BUCKET TO THE GROUND AND STOP THE ENGINE. 2 REMOVE THE REAR PIN FROM THE SAFETY STRUT AND LOWER THE SAFETY STRUT ONTO THE LIFT CYLINDER. 3 START THE ENGINE AND SLOWLY RAISE THE LOADER LIFT ARMS UNTIL THE SAFETY STRUT IS ON THE LIFT CYLINDER ROD. SLOWLY LOWER THE LOADER LIFT ARMS UNTIL THE SAFETY STRUT MAKES CONTACT WITH THE LIFT CYLINDER TUBE. 4 INSTALL THE REAR PIN IN THE SAFETY STRUT. 	<p>PROCEDURE TO PUT THE SAFETY STRUT IN STORAGE</p> <ol style="list-style-type: none"> 1 REMOVE THE REAR PIN FROM THE SAFETY STRUT. 2 START THE ENGINE AND RAISE THE LOADER LIFT ARMS APPROXIMATELY ONE OR TWO INCHES (25 TO 50 mm). 3 USE THE RELEASE LEVER TO RAISE THE SAFETY STRUT ABOVE THE LIFT CYLINDER. 4 SLOWLY LOWER THE LOADER LIFT ARMS UNTIL THE SAFETY STRUT IS ABOVE THE LIFT CYLINDER TUBE. 5 PUT THE RELEASE LEVER IN THE STORAGE POSITION. 6 LOWER THE LIFT ARMS TO THE GROUND AND STOP THE ENGINE. HOLD THE SAFETY STRUT IN THE STORAGE POSITION WITH THE REAR PIN.
	<p>800637</p>	

1. 321-6214, SEE FIGURE 21 FOR LOCATION

Figure 22

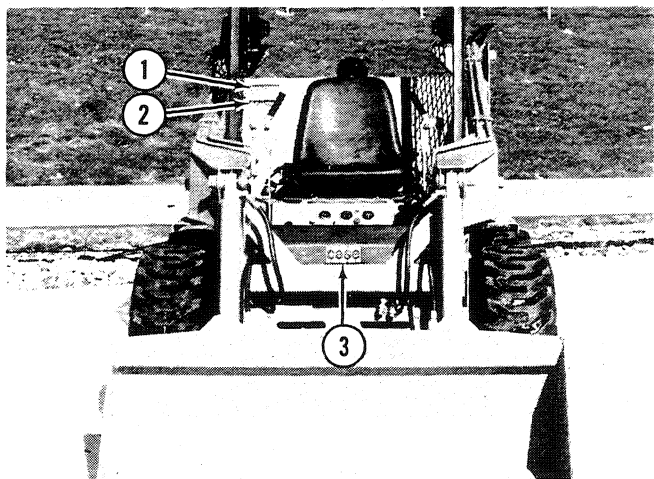

1. 321-5855, See Figure 24
2. 321-3059, See Figure 1
3. 321-4739

Figure 23

WARNING

IF YOU CONNECT JUMPER CABLES WRONG TO THE STARTER MOTOR SOLENOID THE ENGINE CAN BE STARTED WITH THE TRANSMISSION IN GEAR TO PREVENT PERSONAL INJURY OR DAMAGE TO THE MACHINE USE THE FOLLOWING PROCEDURE

- 1 TWO PERSONS ARE REQUIRED FOR JUMP STARTING
- 2 CONNECT THE POSITIVE JUMPER CABLE TO THE BATTERY TERMINAL OF THE STARTER MOTOR SOLENOID
- 3 CONNECT THE NEGATIVE JUMPER CABLE TO A GOOD ENGINE GROUND SEE THE OPERATOR'S MANUAL FOR THIS MACHINE SIT IN THE OPERATOR'S SEAT AND THEN START THE ENGINE
- 4 HAVE THE OTHER PERSON DISCONNECT THE JUMPER CABLES

IF YOU DO NOT USE THE ABOVE PROCEDURE THE MACHINE CAN MOVE OUT OF CONTROL AND YOU OR OTHER PERSONS CAN BE SERIOUSLY INJURED

321 6244

WARNING

DO NOT REMOVE ANY SAFETY EQUIPMENT, SUCH AS ROLLOVER PROTECTIVE STRUCTURE OR SIDE SCREENS (OR SIDE WINDOWS) EXCEPT FOR SERVICING PROPERLY REINSTALL BEFORE USING MACHINE.

321 5855

1 321-5855, SEE FIGURE 23 FOR LOCATION

Figure 24

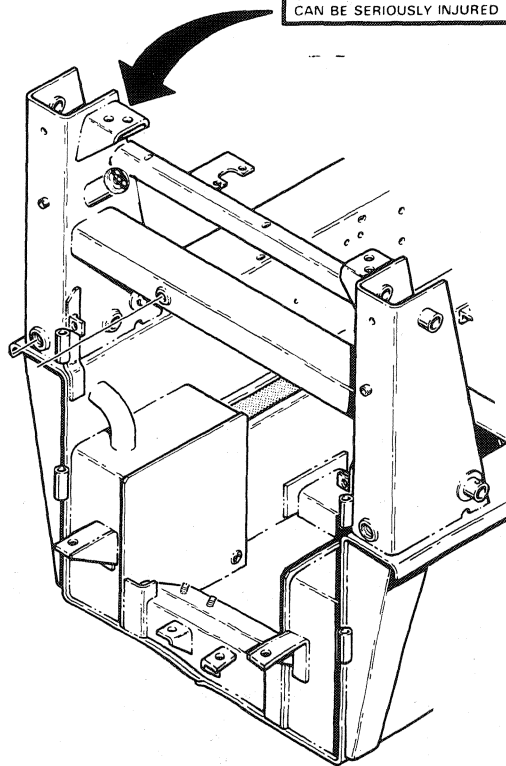

1 321-6244

Figure 25

800640

ENGINE DATA DECAL NO. 321 5845

MODEL	-----	148G
FULL LOAD R P M	-----	2100
NO LOAD R P M	-----	2250
VALVE TAPPET	-----	INTAKE .014 COLD
CLEARANCE	-----	EXHAUST .020 COLD
DISTRIBUTOR TIMING AT 2100 ENGINE R P M	-----	35 BTC
DISTRIBUTOR POINT GAP	-----	020
SPARK PLUG GAP	-----	025

①

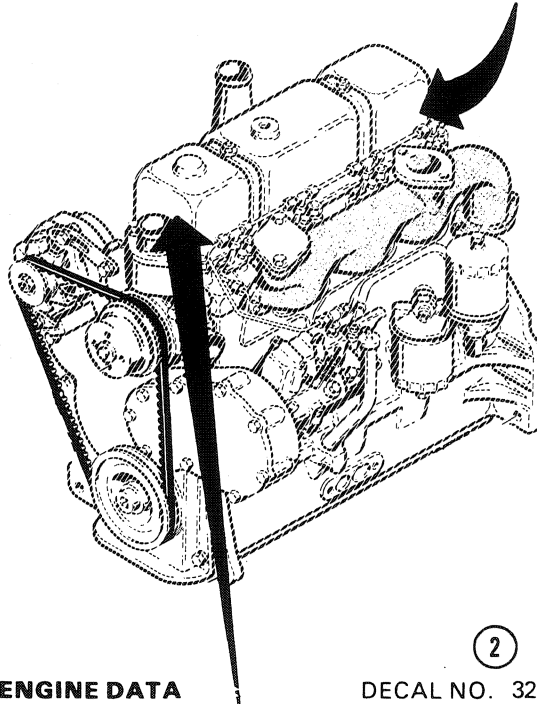

②

ENGINE DATA

DECAL NO. 321-4291

MODEL	-----	G188D
FULL LOAD R.P.M.	-----	2100
NO LOAD R.P.M.	-----	2250
VALVE TAPPET	_INTAKE	_.012 COLD
CLEARANCE	_ EXHAUST	_.014 COLD
FUEL PUMP TIMING	-----	4° B.T.C.
NOZZLE OPENING PRESS.	---	3000 P.S.I.

1. 321-5845 GASOLINE ENGINE
2. 321-4291 DIESEL ENGINE

800641

Figure 26

INSTALLATION INSTRUCTIONS FOR M20611 TEFLON VALVE SEAL KIT

Special Tools Required



M20624 SEAL INSTALLATION TOOL

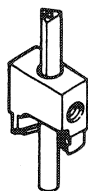

M20615 VALVE GUIDE CUTTING TOOL

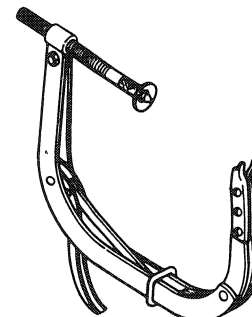

VALVE SPRING COMPRESSOR

STEP 1

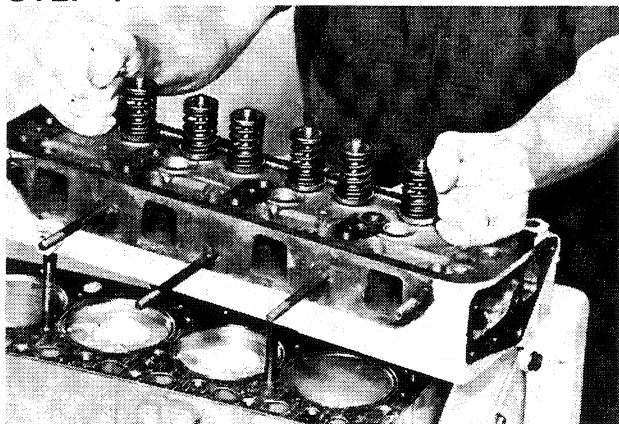

Remove the cylinder head from the engine block. Refer to section 2015 for head removal. **NOTE:** This cylinder head requires two M20611 Kits.

STEP 2

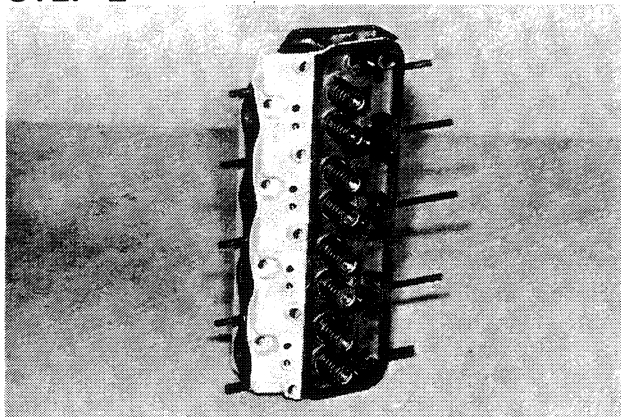

Place cylinder head on work bench.

STEP 3

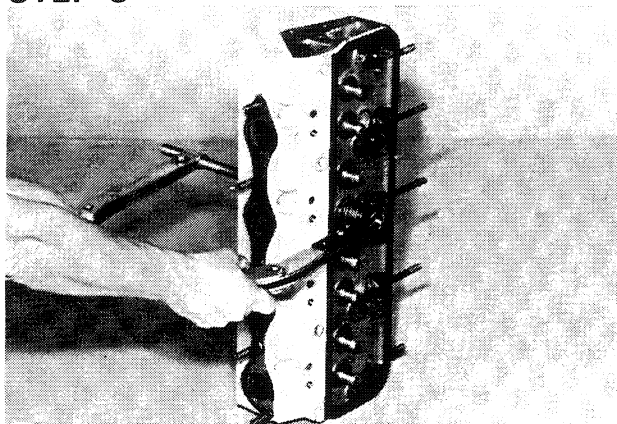

Install a valve spring compressor.

STEP 4

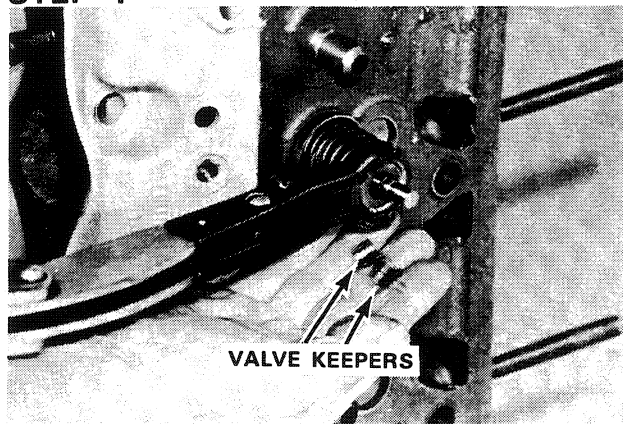

Compress valve spring and remove valve keepers. **IMPORTANT:** Valves and valve keepers should be marked when removed to insure that they will be reinstated in their original location.

STEP 5

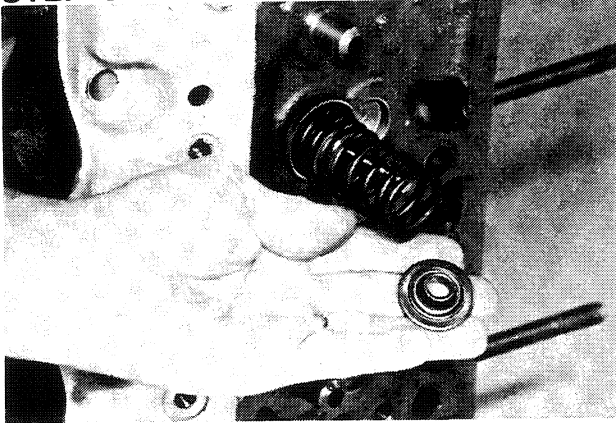

Remove spring retainer.

STEP 8

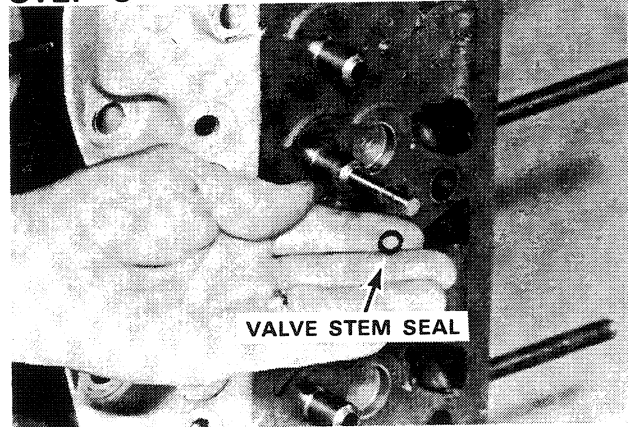

Remove valve stem seal.

STEP 6

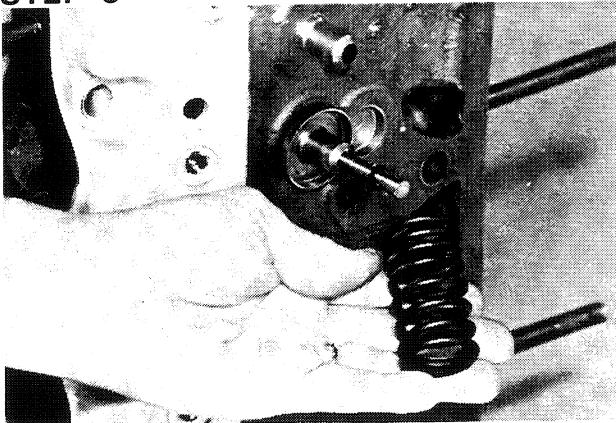

Remove spring.

STEP 9

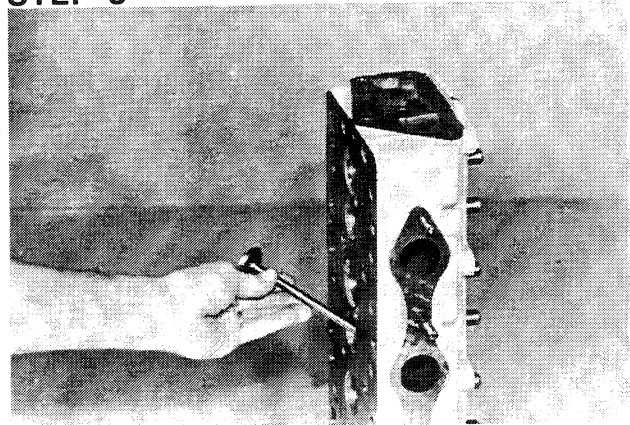

Remove valve.

STEP 7

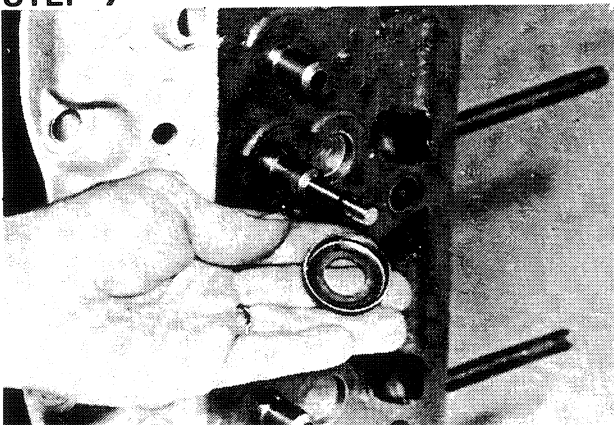

Remove spring seat.

STEP 10

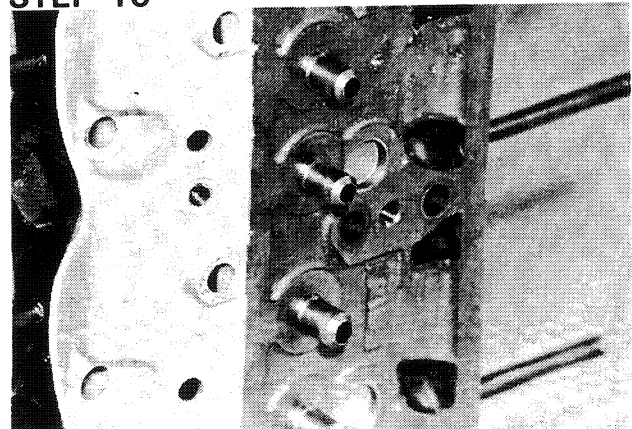

Remove all the valve assemblies.

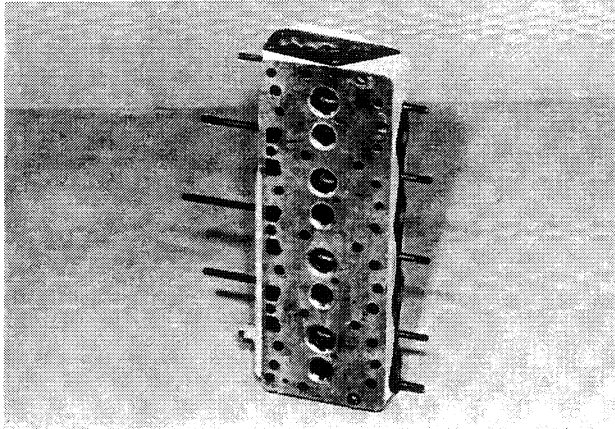
STEP 11

Wash, clean and inspect head. Use a rotary brush to clean around and down into valve ports. Refer to Section 2015 for complete head reconditioning.

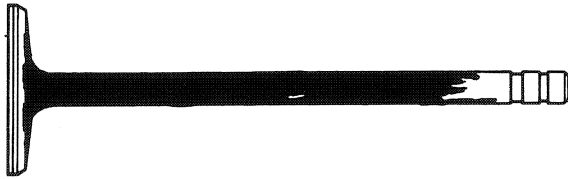
STEP 12

Clean valves with a fine power drive wire brush, removing all carbon and varnish deposits. Be careful not to scratch valve stems. Refer to Section 2015 for valve inspection.

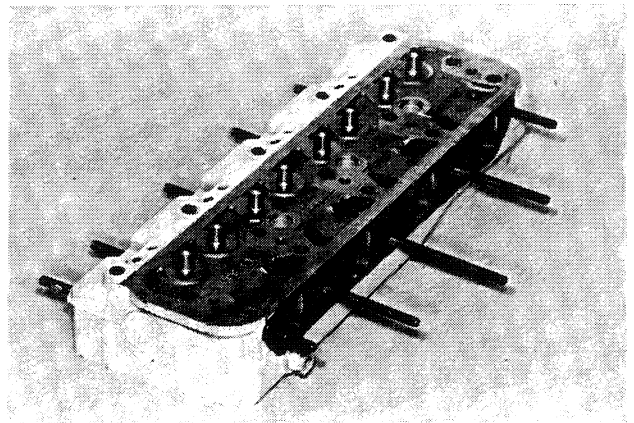
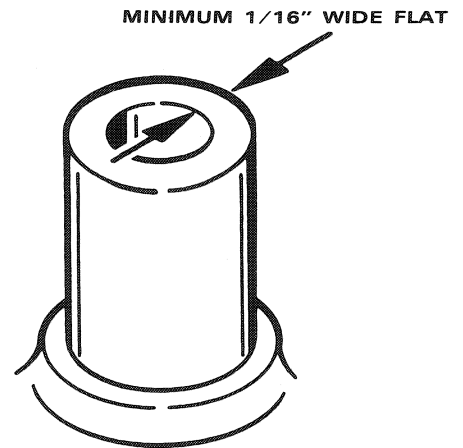
STEP 13

Check valve guide top surface. There must be a minimum of a 1/16" wide flat around entire top surface.

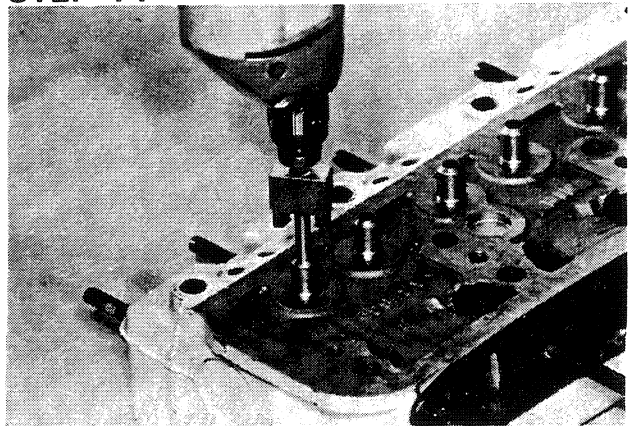
STEP 14

Use M20615 tool in a electric drill (if required) to provide necessary flat area on valve guide. **IMPORTANT:** Do not exceed 450 RPM drill speed when using valve guide cutting tool.

STEP 15

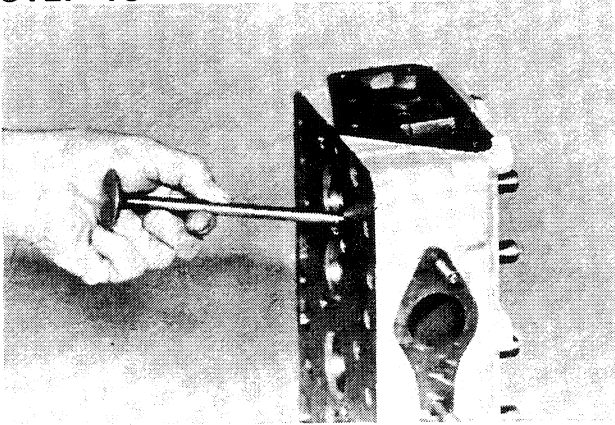

Dip valve stems into HDM #30 oil before assembly in cylinder head.

STEP 18

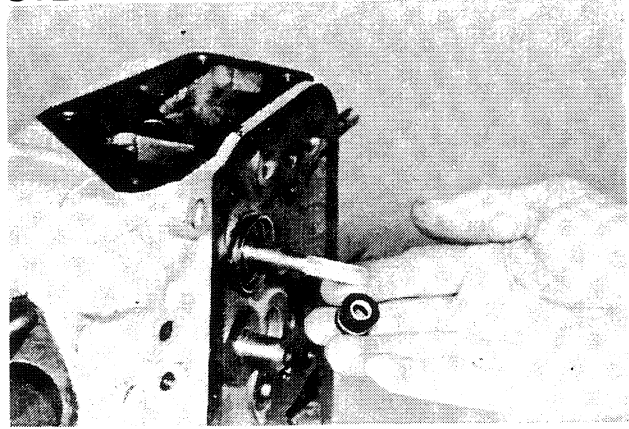

Carefully start valve seal on cap and hold thumb against white seal insert to avoid dislodging it. Push seal down until seal jacket touches top of valve guide.

STEP 16

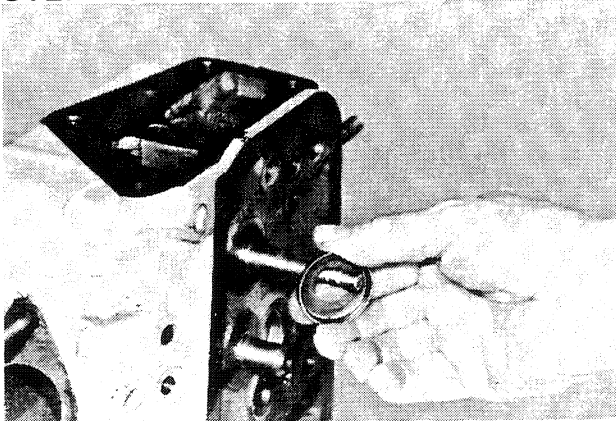

Install spring seat.

STEP 19

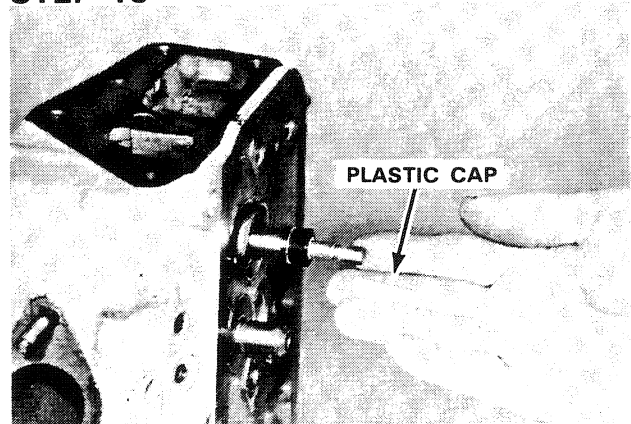

Remove installation cap and save, since it must be reused.

STEP 17

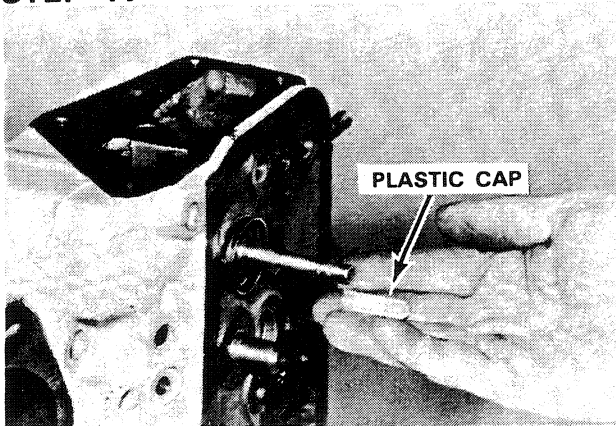

Place plastic installation cap, provided in kit, on the end of the valve stem. **NOTE:** Cap prevents sharp edges on valve stem grooves from cutting valve seal.

STEP 20

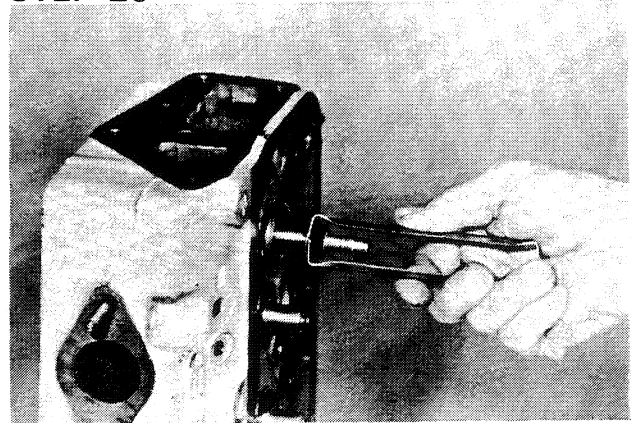

Use M20624 tool and press seal down over valve guide until seal is flush with top of guide.

STEP 21

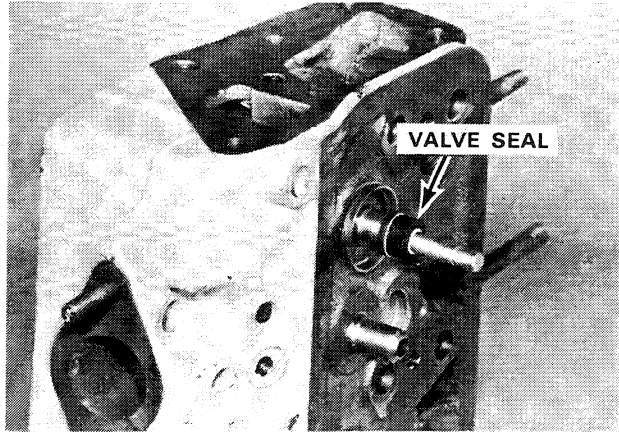

Valve seal installed.

STEP 23

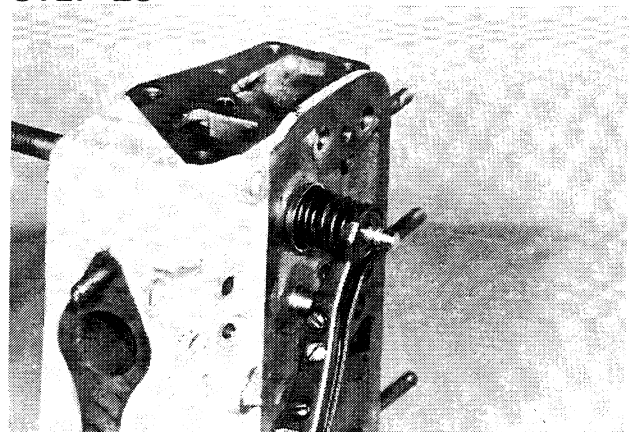

Install valve spring compressor.

STEP 22

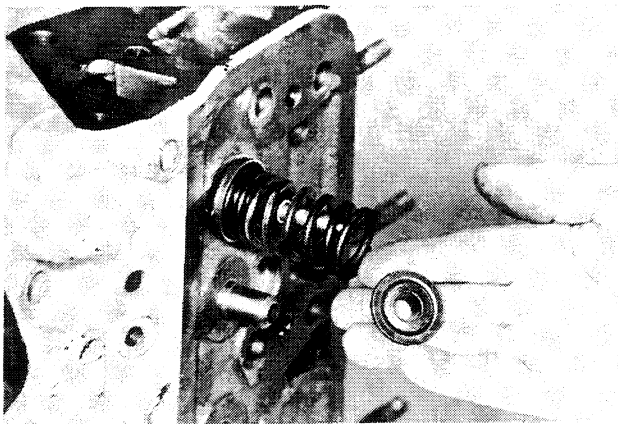
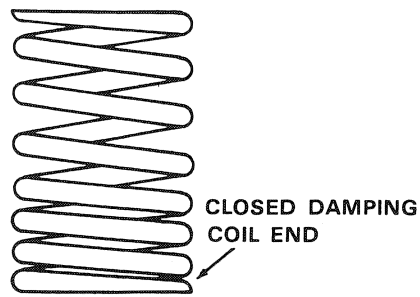

Install spring (damping coil end down) and spring retainer.

STEP 24

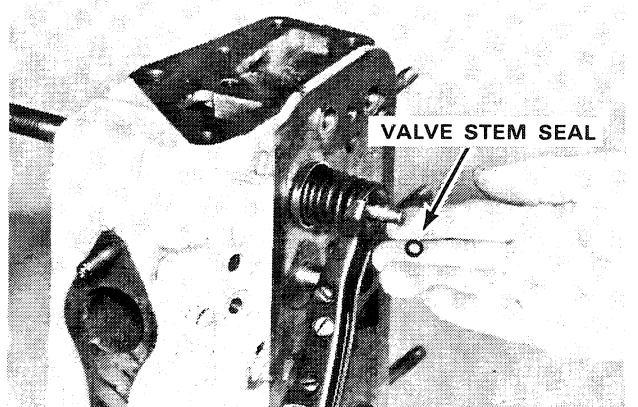

Install stem seal in lower valve stem groove.

STEP 25

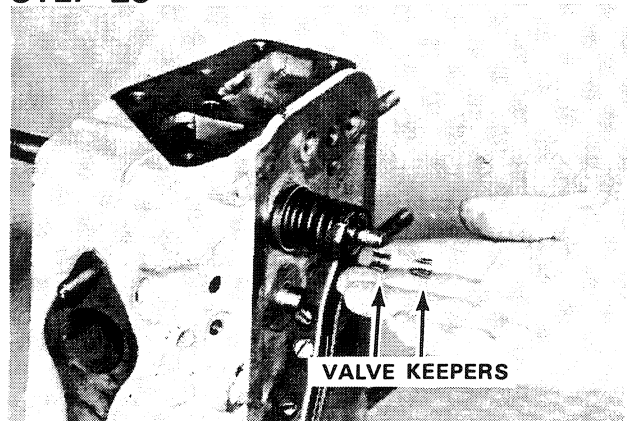

Install valve keepers in outer valve stem groove.

STEP 26

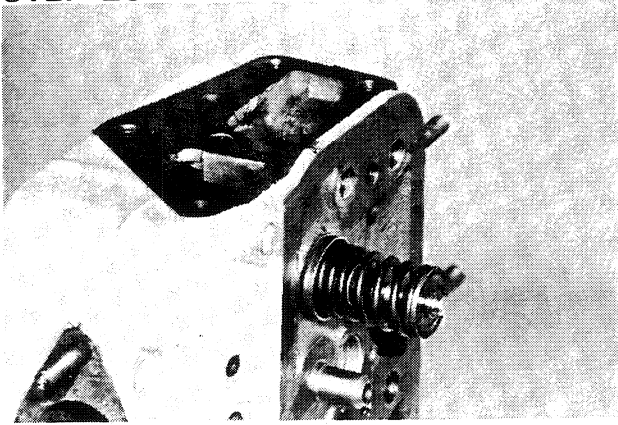

Remove spring compressor and tap valve stem end to seat keepers.

STEP 28

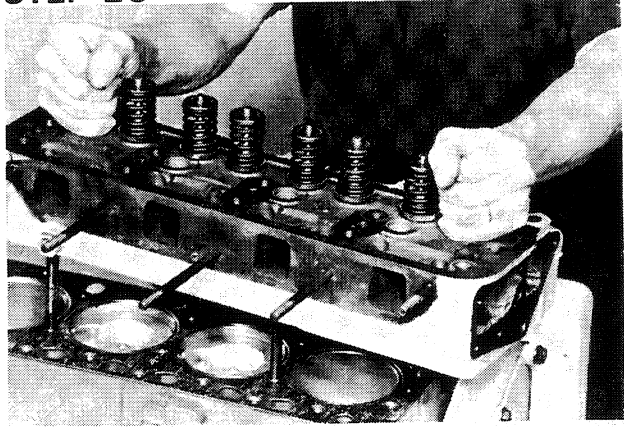

Install cylinder head on engine block following procedure outlined in Section 2015.

STEP 27

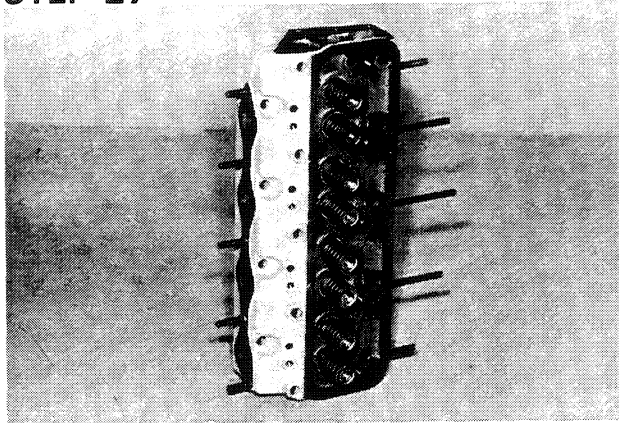

Install teflon seals on the other intake and exhaust valves, following the preceding procedure.

NOTE: The Case Corporation reserves the right to make improvements in design or changes in specifications at any time without incurring any obligation to install them on units previously sold.



THIS SAFETY ALERT SYMBOL INDICATES IMPORTANT SAFETY MESSAGES IN THIS MANUAL. WHEN YOU SEE THIS SYMBOL, CAREFULLY READ THE MESSAGE THAT FOLLOWS AND BE ALERT TO THE POSSIBILITY OF PERSONAL INJURY OR DEATH.

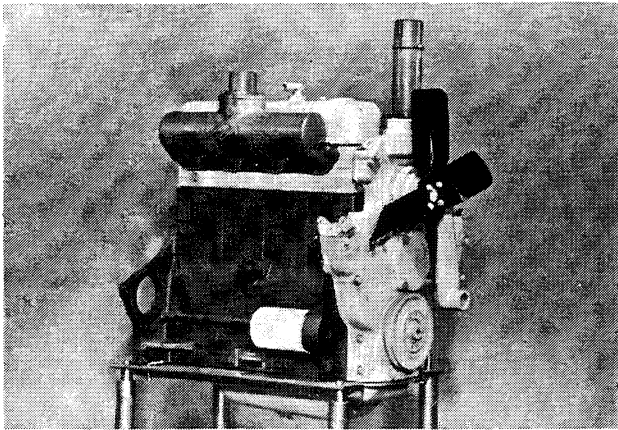

188 DIESEL ENGINE

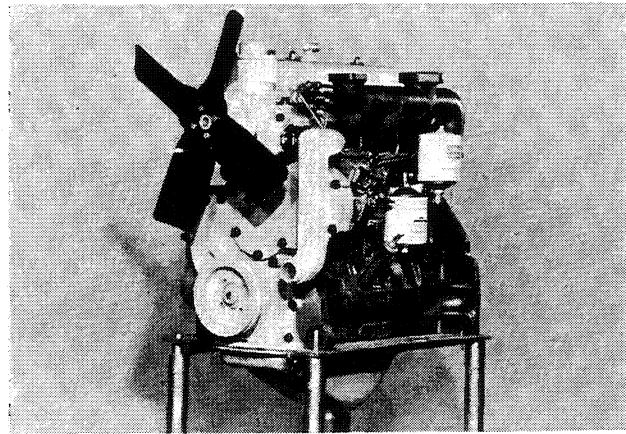

207 DIESEL ENGINE

SPECIAL TOOLS

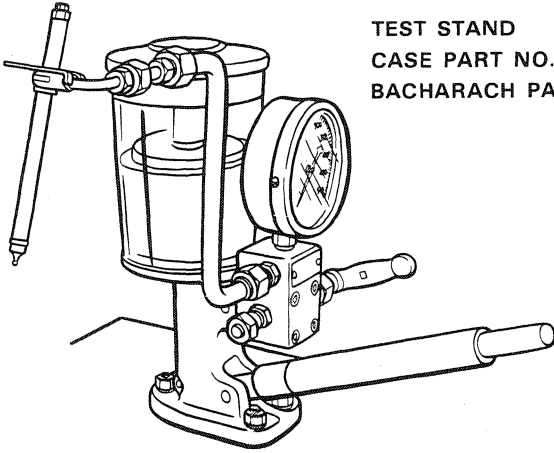

TEST STAND
CASE PART NO. M20322
BACHARACH PART NO. 65-934D

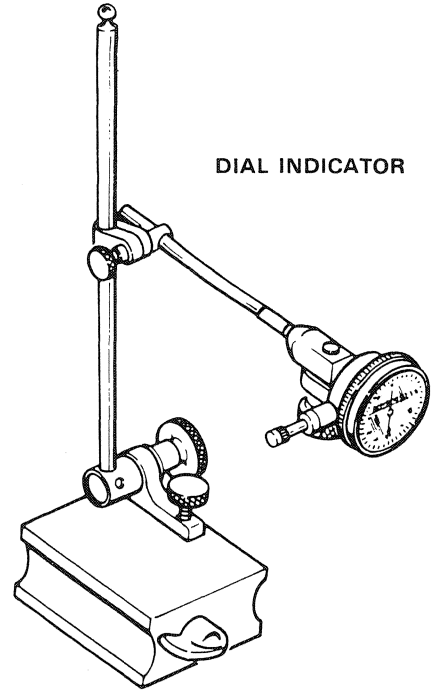

DIAL INDICATOR

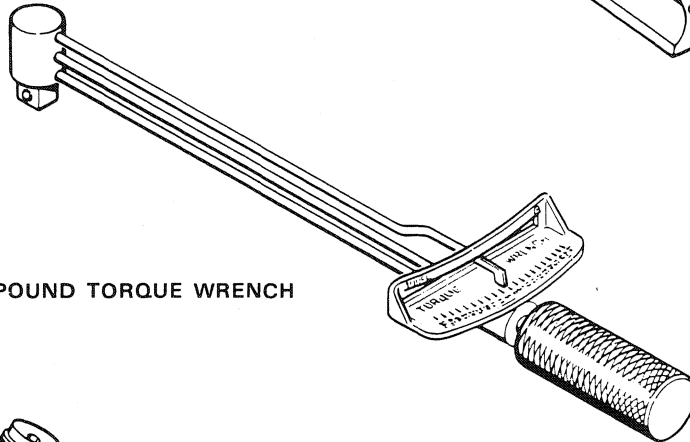

INCH POUND AND FOOT POUND TORQUE WRENCH

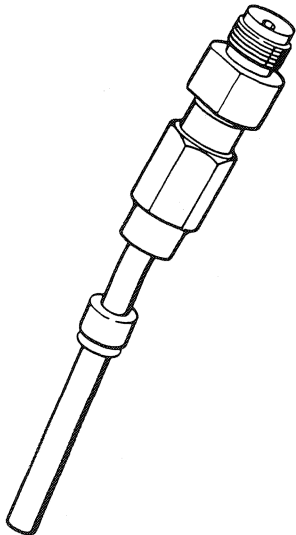

COMPRESSION GAUGE ADAPTER
BACHARACH 70-0314 (D-558)
PART OF CASE M20520 KIT



A43278 INJECTOR
REMOVAL TOOL



A43277 INJECTOR
BORE CLEANER

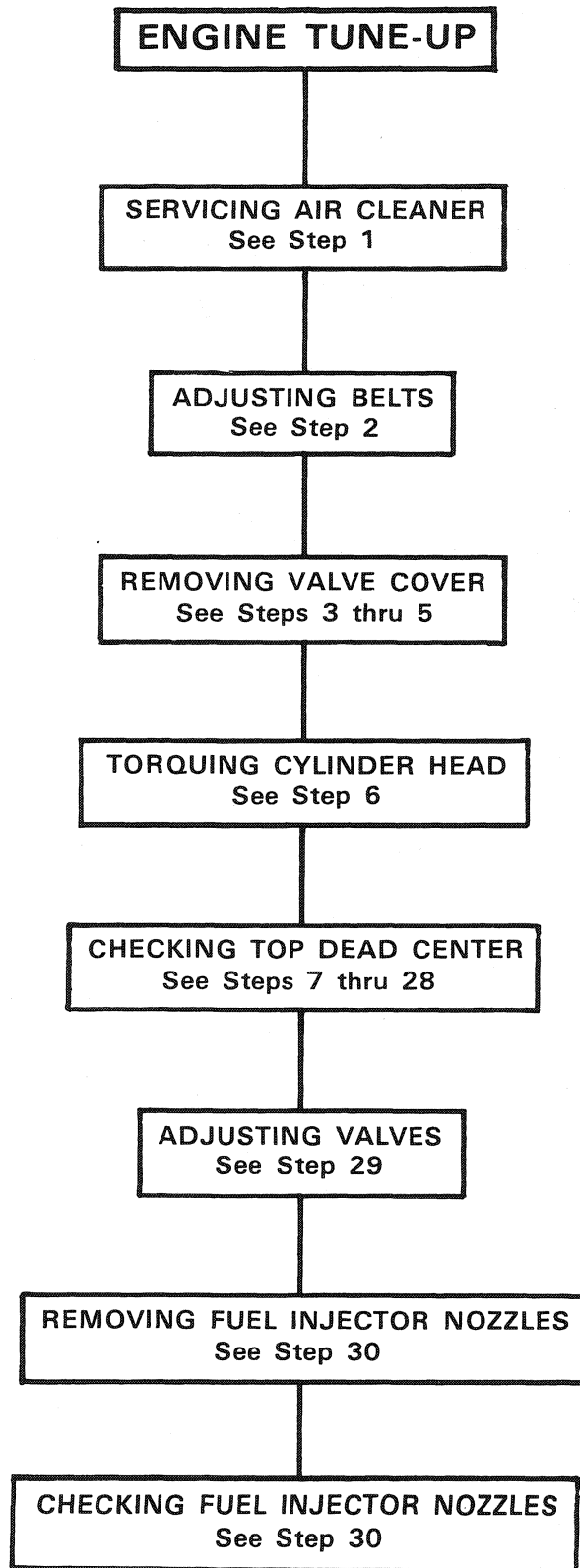

CONTINUED ON NEXT PAGE

ENGINE TUNE-UP CONTINUED

CHECKING COMPRESSION
See Steps 31 thru 38

INSTALLING FUEL INJECTOR NOZZLES
See Step 39

CLEANING FUEL LINE SCREEN AND FUEL FILTERS
See Step 40

RETIMING FUEL INJECTION PUMP
See Steps 41 thru 49

INSTALLING VALVE COVER
See Steps 50 thru 53

ADJUSTING GOVERNED SPEED
See Step 54

ENGINE TUNE-UP PROCEDURE

STEP 1

Service the air cleaner. Refer to your Operator's Manual.

STEP 2

Adjust the belts. Refer to your Operator's Manual.

STEP 3

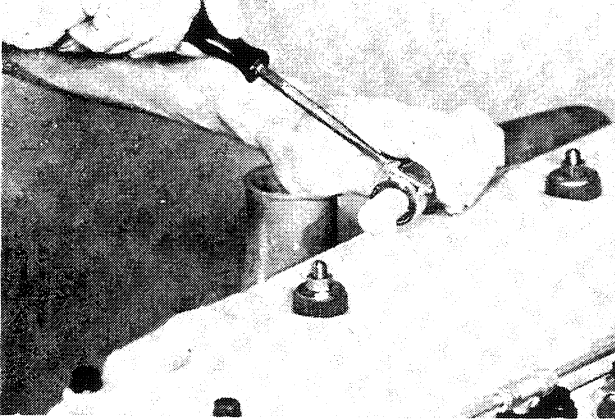

Remove breather tube.

STEP 4

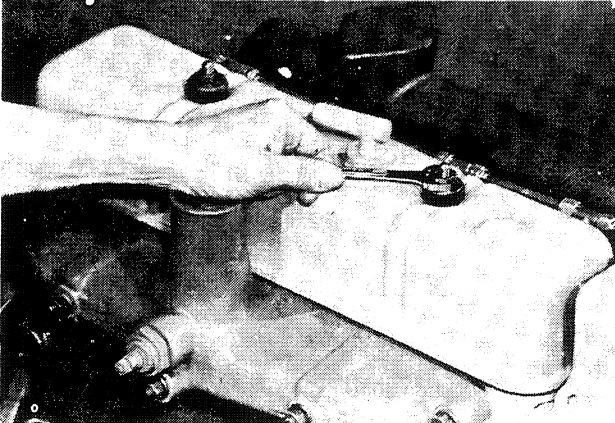

Remove valve cover mounting nuts and grommets.

STEP 5

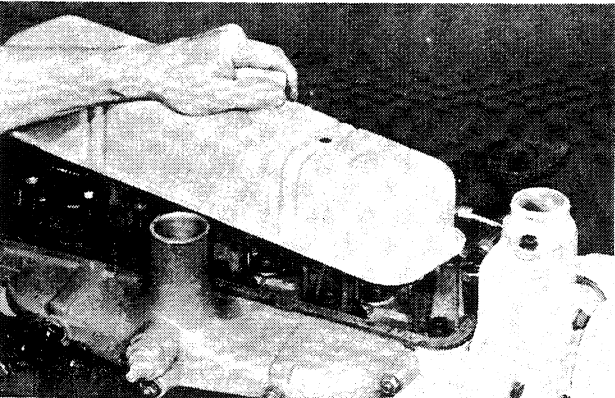

Remove valve cover and gasket.

STEP 6

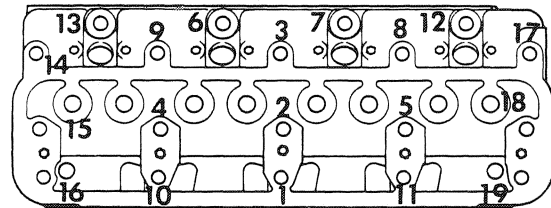
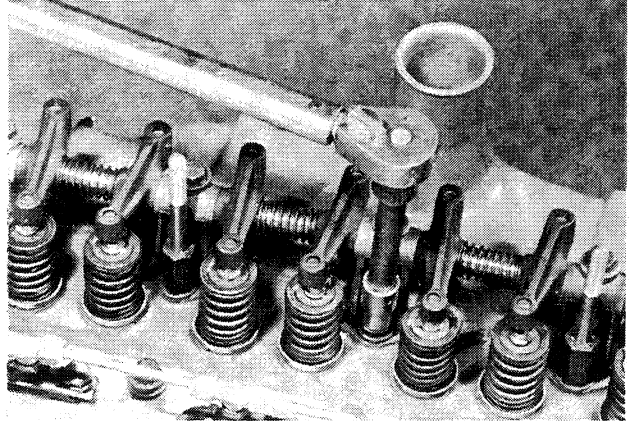

FAN →

Loosen each cylinder head bolt or nut approximately 1/4 turn and then tighten bolt or nut to the specified torquing procedure as listed below and in sequence as shown above. **NOTE:** Do not loosen all nuts or bolts simultaneously but loosen and tighten each individual bolt and nut in the prescribed sequence. The bolt or nut is backed off 1/4 turn to break the set of the threads caused by heat, high stress and oxidation. If this is not done, a false reading is obtained.

1. Nuts w/hardened washers - torque 95-105 ft.lbs.
2. Grade 8, 12 pt. hd. bolts - torque 110-115 ft. lbs.
3. Flanged nuts - torque 90-100 ft. lbs.

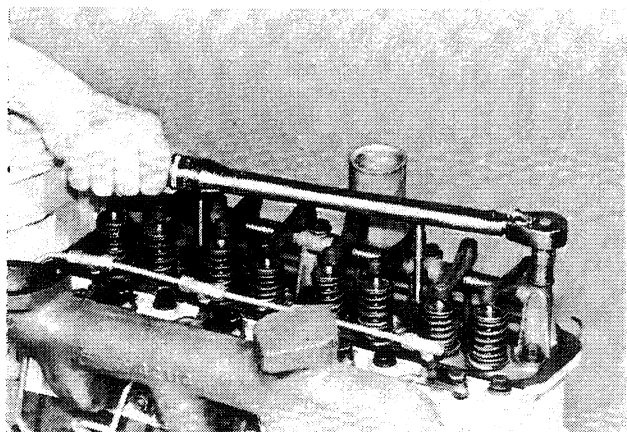

Torque rocker arm mounting bracket bolts to insure that the bolts have retained 25 to 30 ft. lbs. torque.

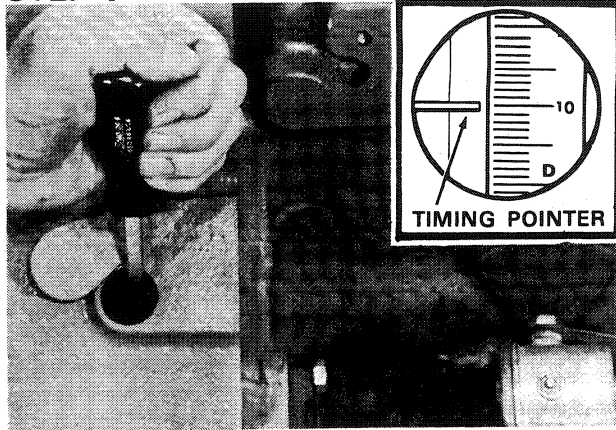
STEP 7

Crank engine by inserting a screwdriver into the timing hole in the flywheel housing or torque tube, and by engaging the ring gear teeth with the screwdriver, align the timing pointer with the 10° BTDC mark on the flywheel.

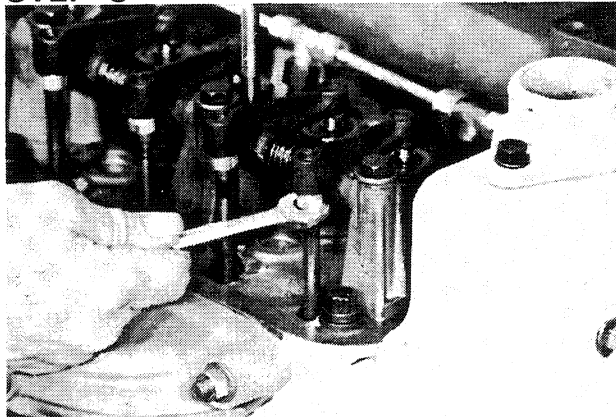
STEP 8

Turn the rocker arm adjusting screw on number one cylinder intake valve inwards to take pressure off the push rod.

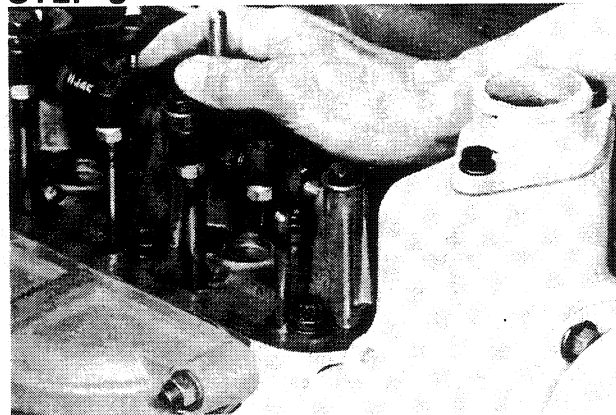
STEP 9

Push down on the number one cylinder intake valve spring and at the same time push the rocker arm assembly rearwards.

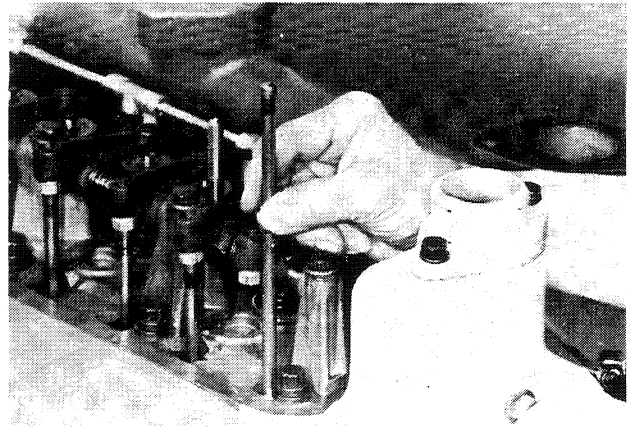
STEP 10

Remove the push rod.

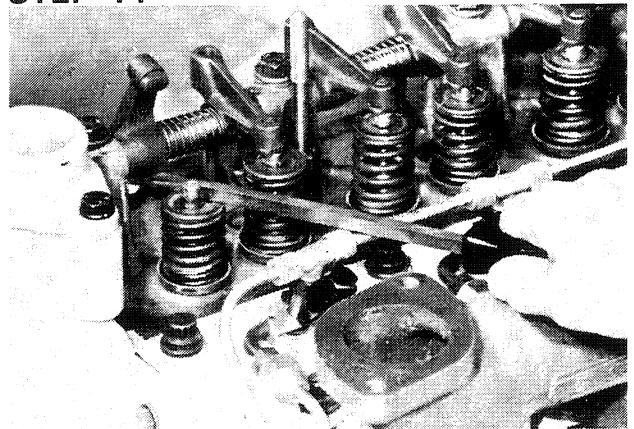
STEP 11

Compress exhaust valve spring on number one cylinder by using a screwdriver.

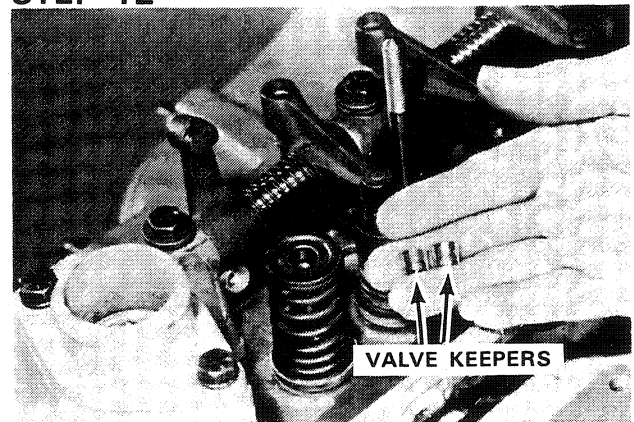
STEP 12

Remove the valve keepers.

STEP 13

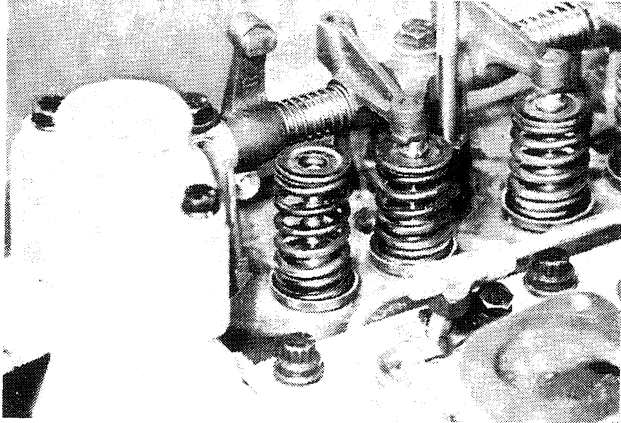

Valve keepers removed.

STEP 14

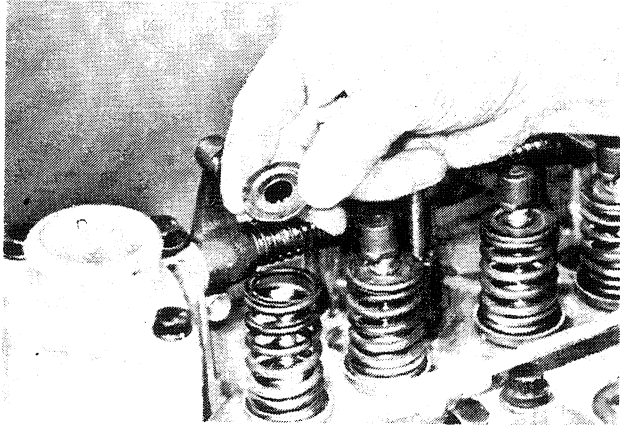

Remove valve spring retainer.

STEP 15

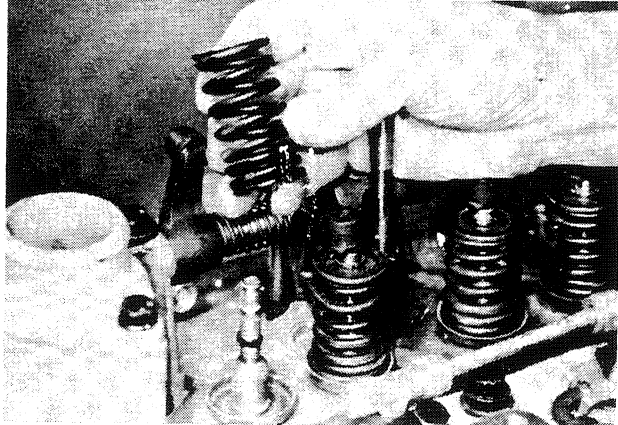

Remove valve spring.

STEP 16

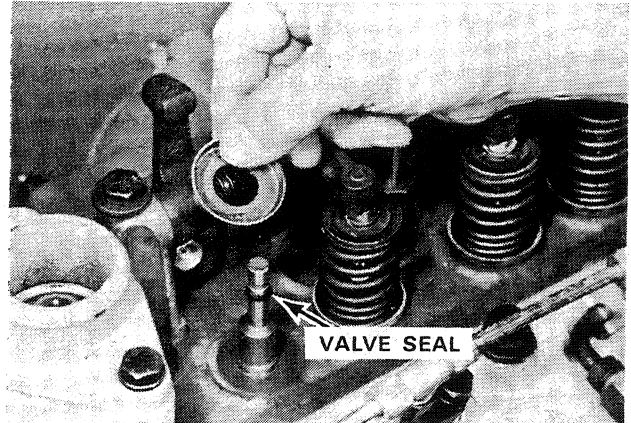

Remove valve spring seat. *NOTE:* Keep valve seal in place to prevent valve from falling through valve guide if the piston is moved too far.

STEP 17

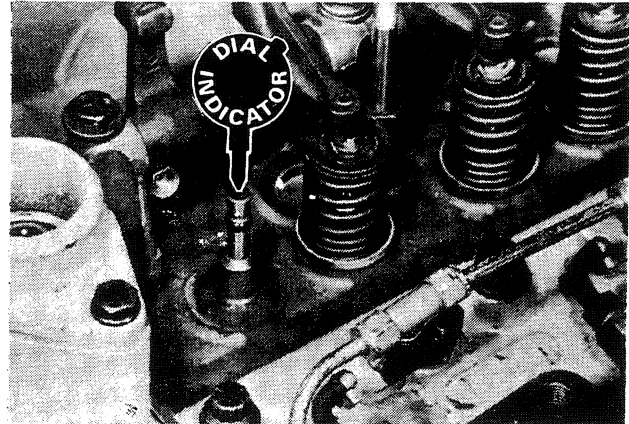

Install dial indicator on end of valve stem with valve resting on top of piston.

STEP 18

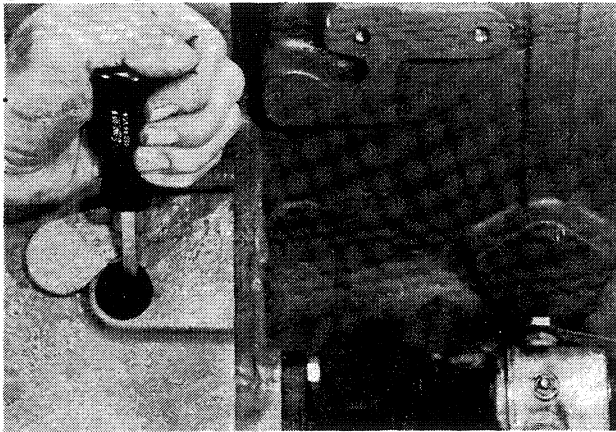

Crank engine clockwise until dial indicator hand stops moving. Reset indicator to zero.

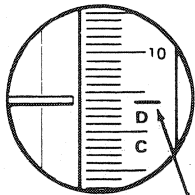

Crank engine clockwise until .010" shows on the dial indicator. Scribe a mark on the flywheel in line with timing pointer.

SCRIBE MARK

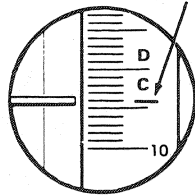

Crank engine counter-clockwise past zero mark on indicator until .010" shows on the dial indicator. Again, scribe a mark on the flywheel in line with timing pointer.

STEP 19

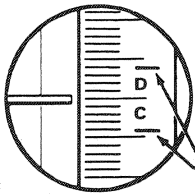

Half the distance between these two scribe marks on the flywheel will be the top dead center (TDC).

SCRIBE MARKS

STEP 20

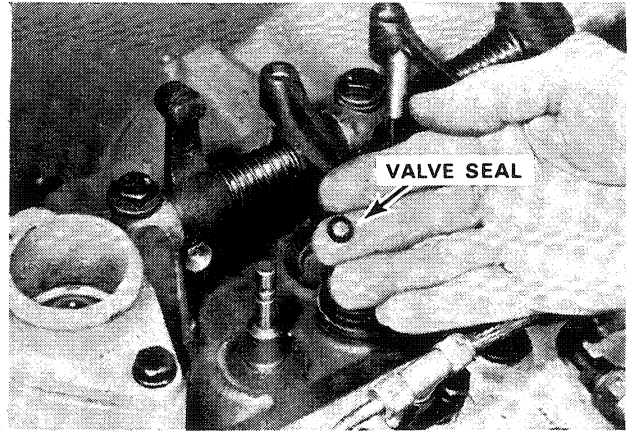

Remove valve stem seal from lower valve stem groove.

STEP 21

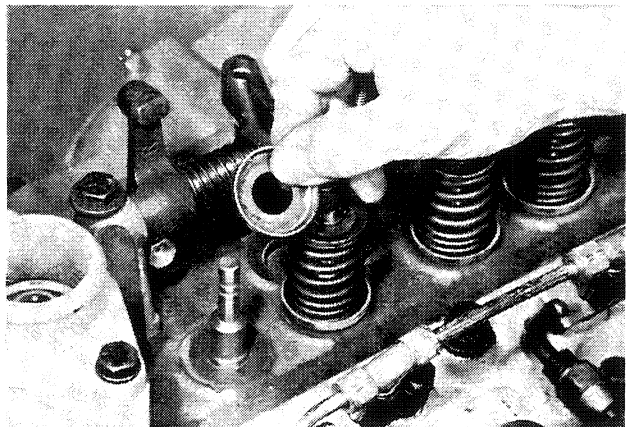

Install the spring seat.

STEP 22

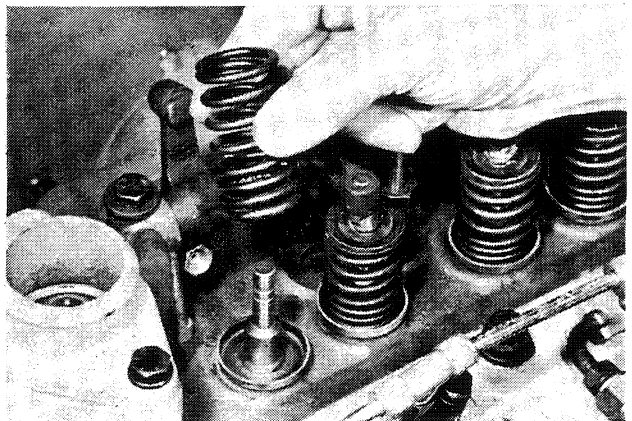
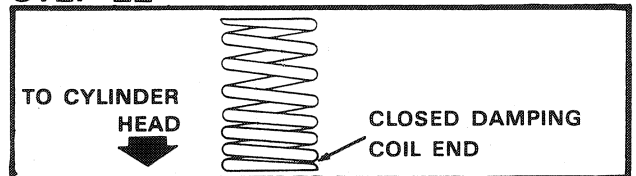

Install the spring with the damping coil end on top of the cylinder head. See inset above.

STEP 23

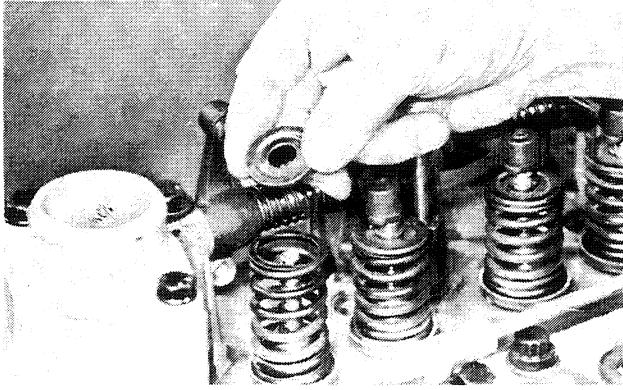

Install the spring retainer.

STEP 26

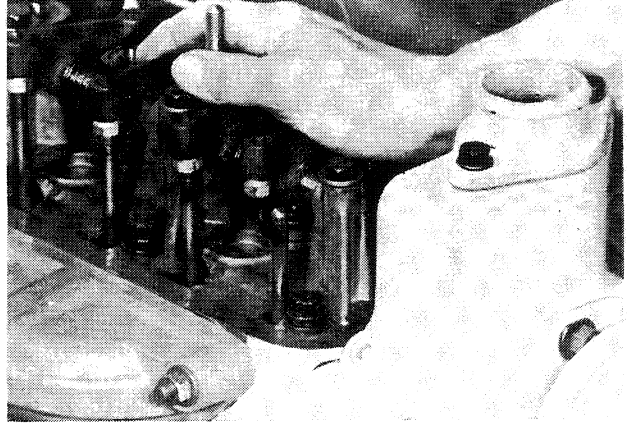

Push back the rocker arm assembly.

STEP 24

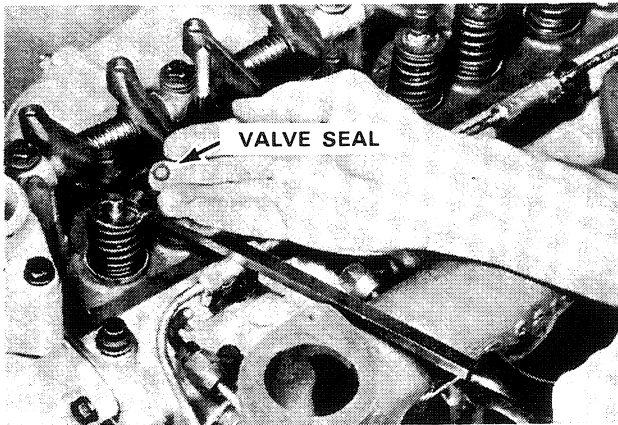

Compress valve spring using a screwdriver and install a new valve stem seal in the lower groove.

STEP 27



Install the push rod.

STEP 25



Keeping the valve spring compressed, install the valve keepers in the upper valve stem groove. Remove screwdriver and tap end of valve stem to seat keepers.

STEP 28



Release rocker arm assembly and position push rod beneath rocker arm adjusting screw.



Suggest:

If the above button click is invalid.

Please download this document

first, and then click the above link

to download the complete manual.

Thank you so much for reading

STEP 29

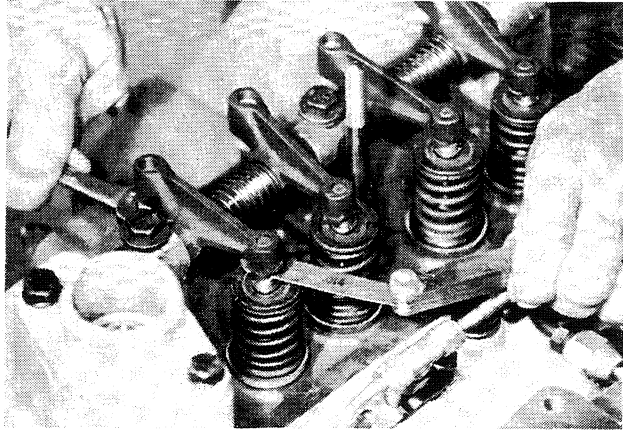

Check and adjust the intake and exhaust valves as pointed out by the arrows below.

Tapet Clearance - Intake Valves .012"
Exhaust Valves .014"

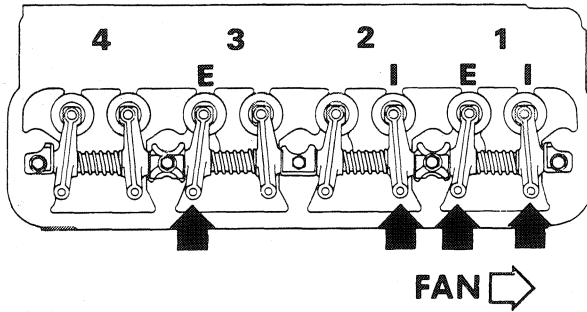

NO. 1 TDC COMPRESSION STROKE

Crank the engine one complete revolution and align the timing pointer with the TDC mark on the flywheel.

Check and adjust the intake and exhaust valves as pointed out by the arrows below.

Tapet Clearance - Intake Valves .012"
Exhaust Valves .014"

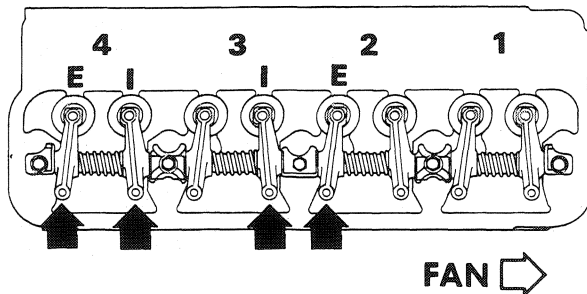

NO. 4 TDC COMPRESSION STROKE

STEP 30

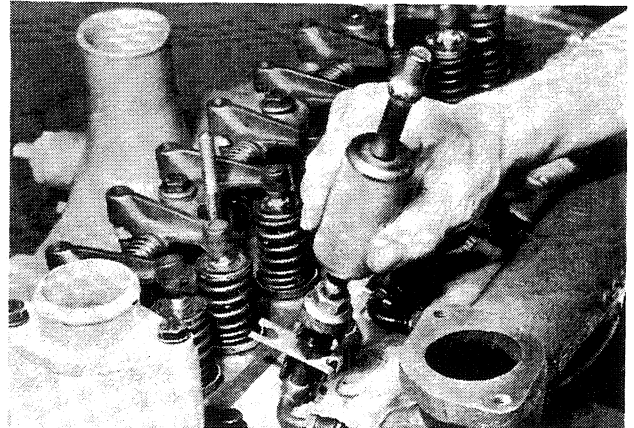

Remove and check each fuel injector. Refer to Section 3013.

STEP 31

Perform a compression test on each cylinder before installing fuel injector.

There are two methods of checking compression pressure - the cranking method and the engine running method. The engine must be at operating temperature for either method used.

A. CRANKING METHOD - Remove all fuel injectors.

B. RUNNING METHOD - Disconnect high pressure fuel line and leak-off line from No. 1 injector. Route fuel from these lines back to fuel tank or clean container. Repeat for each cylinder.

CAUTION Before cranking engine, make sure all operating controls are in neutral, brakes are set and wheels are securely blocked.

<https://www.ebooklibonline.com>

Hello dear friend!

Thank you very much for reading.

Enter the link into your browser.

The full manual is available for immediate download.

<https://www.ebooklibonline.com>