

# 1816, 1816B, AND 1816C UNI-LOADERS

## TABLE OF CONTENTS

DIVISION/SECTION	SECTION NO.	FORM NO.
<b>1 GENERAL</b>		
Safety Rules, Service Manual Introduction, and Torque Specifications .....	1001	8-41040
Maintenance and Lubrication .....	1002	8-41040
Engine Specifications - 1816C .....	1003	8-41040
<b>2 ENGINES</b>		
Troubleshooting a Hard Starting Engine and D61880 Starter (Square Housing) - 1816 and 1816B .....	2001	8-41040
Engine Troubleshooting .....	2002	8-41040
Engine Removal and Installation - 1816 and 1816B and Drive Belts - 1816 .....	2003	8-41040
Engine Removal Installation, 1816C .....	2004	8-41040
Tecumseh Engines Mechanic's Handbook - 1816 and 1816B .....		691462A
Onan Engine - 1816C .....	2006	8-41040
Engine Accessories .....	2007	8-41040
<b>3 FUEL SYSTEM</b>		
Engine Controls, Fuel Lines, Fuel Filter, Electric Fuel Pump .....	3001	8-41040
Carburetor - 1816C .....	3002	8-41040
<b>4 ELECTRICAL</b>		
Electrical System Troubleshooting .....	4002	8-41040
Wiring Diagrams .....	4003	8-41040
Gauges .....	4004	8-41040
Battery .....	4005	8-41040
Starter .....	4006	8-41040
<b>NOTE:</b> Also see the following sections:		
Starter - 1816 and 1816B .....	Sections 2001 and 2005	
Alternator - 1816, 1816B .....	Sections 2001 and 2005	
Alternator - 1816C .....	Sections 2006 and 4002	
Spark Ignition System - 1816, 1816B .....	Sections 2001 and 2005	
Spark Ignition System - 1816C .....	Sections 2006 and 4002	
<b>6 POWER TRAIN</b>		
Hydrostatic Troubleshooting, Testing, and Adjustment for Machines with Vickers Piston Pumps .....	6001	8-41040
Hydrostatic Troubleshooting, Testing, and Adjustment for Machines with Sundstrand Piston Pumps .....	6002	8-41040
Hydrostatic System Diagrams and Operation for Machines with Vickers Piston Pumps .....	6003	8-41040
Hydrostatic System Diagrams and Operation for Machines with Sundstrand Piston Pumps .....	6004	8-41040
Vickers Piston Pump .....	6005	8-41040
Sundstrand Piston Pump .....	6006	8-41040
Hydrostatic Motor .....	6007	8-41040

Reprinted

DIVISION/SECTION	SECTION NO.	FORM NO.
6 POWER TRAIN (CONT'D)		
Hydrostatic Controls for Machines with Vickers Piston Pumps . . .	6008	8-41040
Hydrostatic Controls for Machines with Sunstrand Piston Pumps .	6009	8-41040
Centrifugal Clutch - 1816 . . . . .	6010	8-41040
Electric Clutch - 1816 . . . . .	6011	8-41040
Belt Clutch . . . . .	6012	8-41040
Drive Chains, Drive Axles, and Hubs . . . . .	6013	8-41040
Wheels and Tires . . . . .	6014	8-41040
7 BRAKES		
Parking Brake . . . . .	7001	8-41040
8 HYDRAULICS		
Hydraulic Diagrams, Maintenance, and Troubleshooting . . . . .	8002	8-41040
Cleaning the Hydraulic System . . . . .	8003	8-41040
Equipment Pump . . . . .	8005	8-41040
Equipment Control Valve . . . . .	8007	8-41040
Auxiliary Control Valve . . . . .	8031	8-41040
Cylinders . . . . .	8090	8-41040
9 MOUNTED EQUIPMENT/CHASSIS		
Loader . . . . .	9001	8-41040
Pallet Fork, Manure Fork, and Grapple . . . . .	9002	8-41040
ROPS . . . . .	9003	8-41040
Decals and Painting . . . . .	9004	8-41040
Noise Control . . . . .	9005	8-41040

# Section 1001

## SAFETY RULES SERVICE MANUAL INTRODUCTION AND TORQUE SPECIFICATIONS

Written In *Clear  
And  
Simple  
English*

**<https://www.ebooklibonline.com>**

Hello dear friend!

Thank you very much for reading.

Enter the link into your browser.

The full manual is available for immediate download.

**<https://www.ebooklibonline.com>**

## SERVICE MANUAL INTRODUCTION

This service manual has been prepared with the latest service information available. Troubleshooting, removal, disassembly, inspection and installation procedures, and complete specifications and tightening references can be found in most sections. Some sections have drawings but no written procedure because the job is so easily done. This service manual is one of the most important tools available to the service technician.

### Right, Left, Front, and Rear

The terms right-hand and left-hand and front and rear as used in this manual indicate the right and left sides, and front and rear of the machine as seen from the operator's seat for correct operation of the machine or attachment.

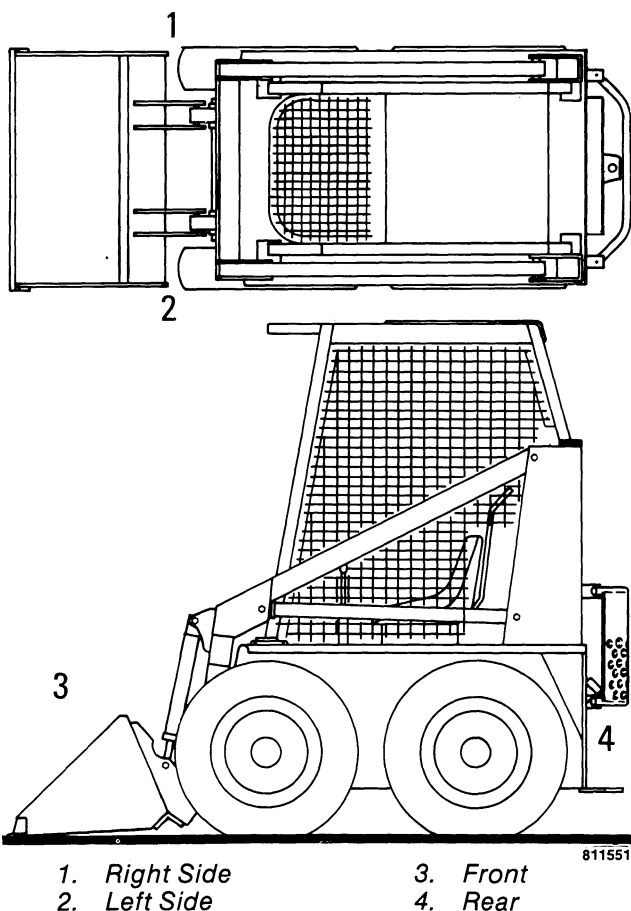

Figure 4

### Text

If the service manual is for more than one machine or different models of components (planetary axles, gear boxes, control valves, etc.) the procedures have the steps necessary to service each model.

### Table of Contents

A Table of Contents is in the front of this manual. The Table of Contents shows the main divisions and the sections that are in each division. The individual sections, where necessary, have a Table of Contents on the second page of that section.

### Page Numbers

All page numbers are made of two numbers separated by a dash, such as 4002-9. The number before the dash is the section number. The number following the dash is the page number in that section. Page numbers will be found at the upper right or left of each page.

### Illustrations

Illustrations are put as near as possible to the text and are to be used as part of the text.

### Classification of Lubricants

The SAE number is the viscosity of engine oils; for example, SAE 30, a single viscosity oil. SAE 10W30 is a variable viscosity oil.

The API classification (SD, CD, etc.) is the oil performance in terms of engine usage. Only oils specified in Section 1002 can be used. These oils have the needed chemical additives to give maximum engine protection. Both the SAE grade and API classification must be found on the container.

### Special Tools

Special tools are needed to remove and install, disassemble and assemble, check and adjust some component parts of this machine. Some special tools can be easily made locally and the necessary information to make the tool is in this service manual. Other special tools are more difficult to make locally and are available from Service Tools in the U.S. and from Jobborn Manufacturing in Canada. Use these tools according to the instructions in this service manual for your personal safety and to do the job correctly.

Order special tools from either of the following companies:

Service Tools  
P.O. Box 314  
Owatonna, Minnesota 55060

Jobborn Manufacturing Co.  
97 Frid Street  
Hamilton, Ontario L8P 4M3  
Canada

## Product Identification Number (PIN) and Serial Numbers

**NOTE 1:** 1816 and 1816B - Engine serial number is on carburetor side of blower housing. ROPS serial number is above operators head at front of the ROPS.

**NOTE 2:** All models - Bucket serial number is on the back of the spillguard.

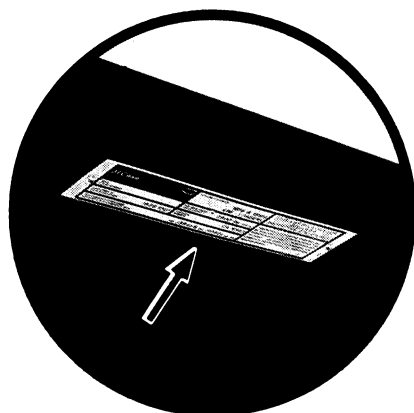

SN OF ROPS  
CANOPY

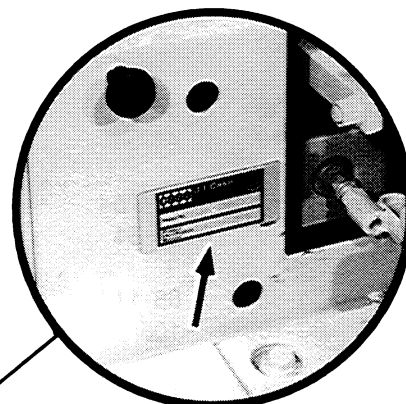

PRODUCT  
IDENTIFICATION NUMBER

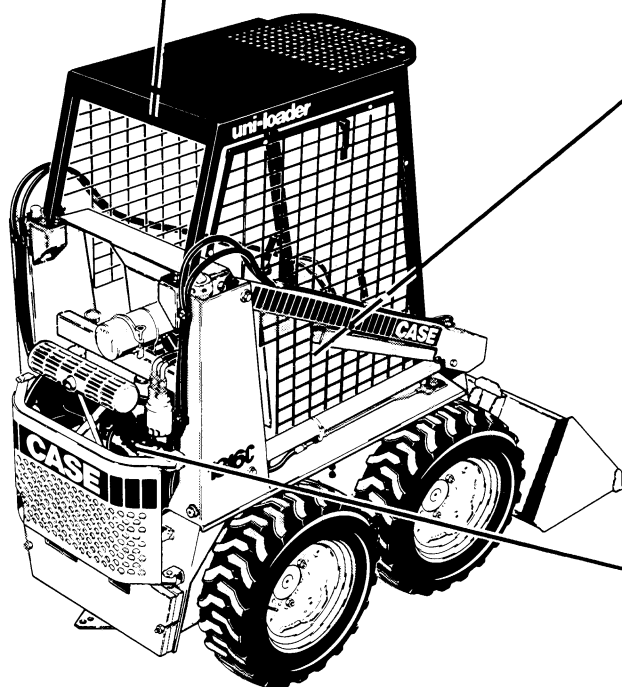

SN OF ENGINE

810225

Figure 5 - 1816C Illustrated

# **Section 2003**

## **ENGINE REMOVAL AND INSTALLATION 1816 AND 1816B AND DRIVE BELTS - MACHINES WITHOUT BELT CLUTCH**

## ENGINE REMOVAL - 1816 AND 1816B

1. Remove the seat and heat shield assembly. Then loosen the hydrostatic pump adapter plate mounting bolts and equipment pump mounting bolts and remove belts from pump sheaves.

**NOTE:** *If the machine is equipped with a belt clutch, the hydrostatic pump belts can be removed when the belt clutch control is in the Off position.*

2. Swing oil cooler out of way. Remove ground cable from engine (below starter) and tape cable end to prevent accidental grounding.

3. Remove cable from starter and disconnect harness at plug from engine.

4. Disconnect choke and throttle cables at carburetor and position out of way.

5. Disconnect fuel line at fuel pump, remove hose from supporting clamp, and secure loose end of hose above fuel tank to prevent siphoning fuel tank.

6. Remove four engine mounting bolts and remove engine.

**NOTE:** *All late production bolts have been installed with Loctite.*

## ENGINE INSTALLATION - 1816 AND 1816B

1. If the machine has a centrifugal clutch or an electric clutch, and the clutch was removed from the engine, see Section 6010 or 6011 for clutch installation.

2. Place drive belts on clutch for models with centrifugal or electric clutch or on the drive sheave for models with belt clutch. Set engine on mounting pads. As the engine is slid into place, install belts on pump sheaves.

**NOTE:** *Early production machines used lock washers with the engine mounting bolts. Discard lock washers and replace with hardened flat washers. Refer to parts catalog.*

3. Position engine in original position as close as possible. Coat engine mounting bolt threads with 242 (blue) Loctite and install bolts. When clutch or drive sheave is parallel to and about 1/8 inch (3 mm) from pump mounting plate, torque mounting bolts to 40 pound-feet (54 N m).

4. Connect fuel line to fuel pump. Install fuel line support clamp.

5. Connect choke and throttle cables to carburetor.

6. Connect wiring harness and starter cable to starter.

7. Connect ground cable to engine below starter.

8. Tighten drive belts as instructed in this section.

**NOTE:** *For machine with belt clutch, see Section 6012 for instructions to tighten drive belts.*

9. If crankcase was drained, fill with oil specified in Section 1002.

10. Swing oil cooler into place and secure with nuts and bolts.

11. Install seat and heat shield assembly.

## DRIVE BELTS - MACHINES WITHOUT BELT CLUTCH

**NOTE:** For machines with belt clutch, see Section 6012.

### Vickers Hydrostatic Pump and Equipment Pump Belts

Due to the time required to replace a belt, careful consideration should be given to replacing all belts at the same time.

#### Removal

1. Remove the seat and heat shield assembly. Then loosen the hydrostatic pump adapter plate mounting bolts and equipment pump mounting bolts and remove belts from pump sheaves.
2. Swing oil cooler out of way. Remove ground cable from engine (below starter) and tape end of cable to prevent accidental grounding.
3. Remove cable from starter and disconnect wiring harness at plug from engine.
4. Disconnect choke and throttle cables at carburetor. Slide engine to rear and remove belts.

#### Installation

1. Place belts on clutch and slide engine into place. As the engine is slid into place, install belts on pump sheaves.
2. Position engine in original position as close as possible and install mounting bolts. When clutch is parallel to and 1/8 inch (3 mm) from pump mounting plate, tighten engine mounting bolts.
3. Connect starter cable to starter and ground cable to engine.
4. Connect choke and throttle cables to carburetor.
5. Adjust belts as instructed under Adjustment.
6. Install the seat and heat shield assembly. Swing oil cooler into place and secure with nuts and bolts.

#### Adjustment

##### Hydrostatic Pump Belt

1. Remove the seat and heat shield assembly.
2. Loosen pump adapter plate mounting bolts and pry against pump to tighten belt.

3. Check belt tension using a spring scale midway between the clutch and pump sheaves.

a. If hydrostatic pumps are staggered (Vickers), belt deflection should be 1/8 inch (3 mm) at 7 - 8 pounds (3.2 - 3.6 kg).

b. If hydrostatic pumps are even (Sundstrand), belt deflection should be .10 inch (2.5 mm) at 5 - 7 pounds (2.3 - 3.2 kg).

4. Make sure adapter plate bolts are tight and install the seat and heat shield assembly.

##### Equipment Pump Belt

1. Loosen pump mounting bolts and pry against pump to tighten belt.
2. Check belt tension using a spring scale. Belt deflection should be 1/8 inch (3 mm) with a scale reading of 3 - 4 pounds (1.4 - 1.8 kg).
3. Make sure pump mounting bolts are tight.

### Sundstrand Hydrostatic Pump and Equipment Pump Belts

All belts can be removed without removing the engine. Both hydrostatic pump belts must be removed if the equipment pump belt is to be removed. If the left hydrostatic pump belt is to be removed, the right hydrostatic pump belt must be removed also.

#### Removal

1. Remove the seat and heat shield assembly and side screens.
2. Loosen pump adapter plate mounting bolts as required and remove belt from pump sheaves.
3. Work belts to front of clutch sheave and remove belts.

#### Installation

1. If all belts were removed, install the equipment pump belt first.
2. Install belts from front of clutch and place in proper groove in clutch sheave, see Figure 2.
3. Place belts in pump sheaves and adjust belt tension as instructed under Adjustment.
4. Install side screens and seat and heat shield assembly.

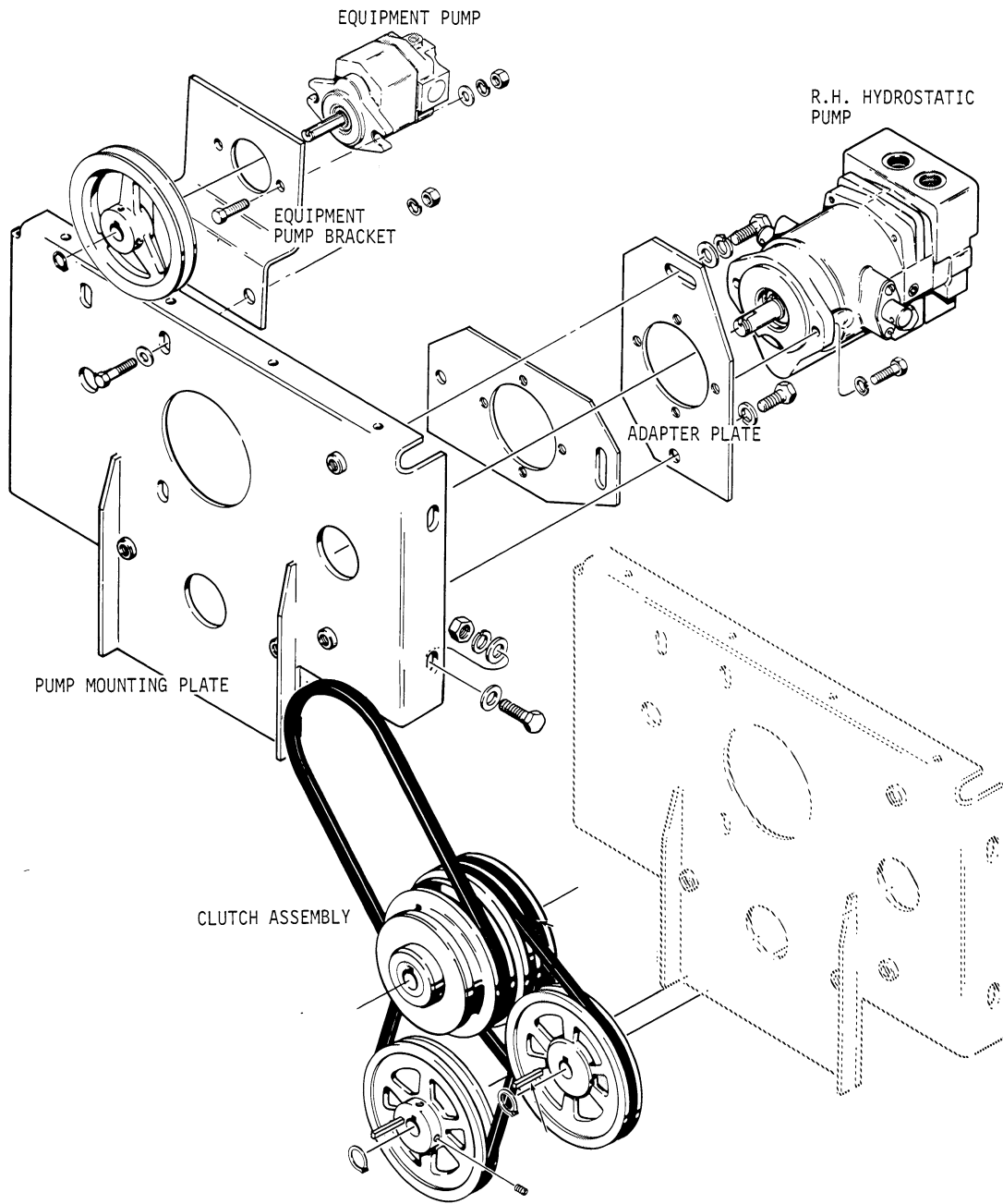

730236

Figure 1 - Pump Installation, Early Production

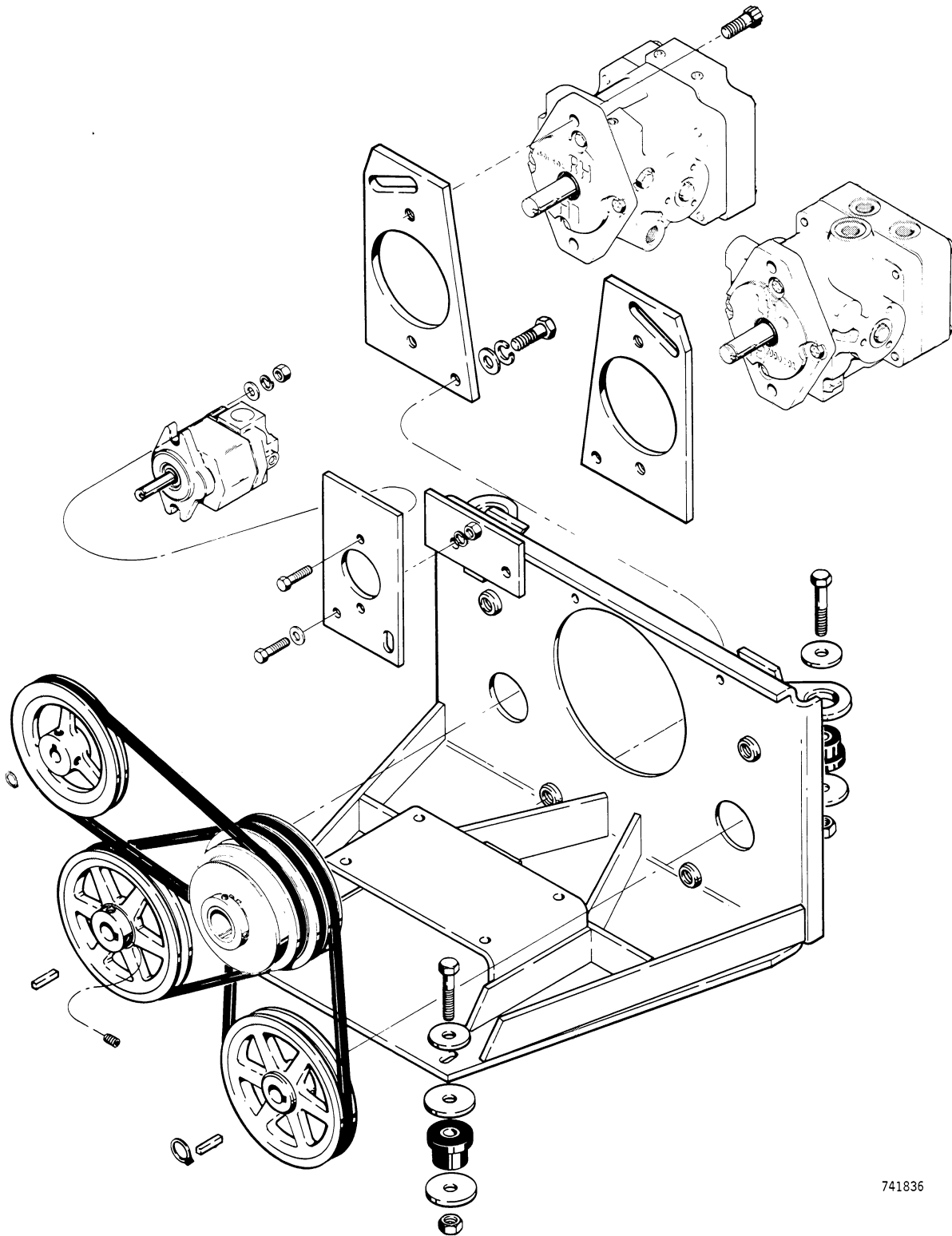

741836

Figure 2 - Pump Installation, Late Production

# Section 2004

## ENGINE REMOVAL AND ENGINE INSTALLATION - 1816C

Written In *Clear  
And  
Simple  
English*

## ENGINE REMOVAL

1. Park the machine on a level surface.
2. Raise the loader frame and use the support strut to fasten the loader frame in position.
3. Put the belt clutch control in the OFF position.
4. Stop the engine.
5. Remove the RH side screen from the machine.

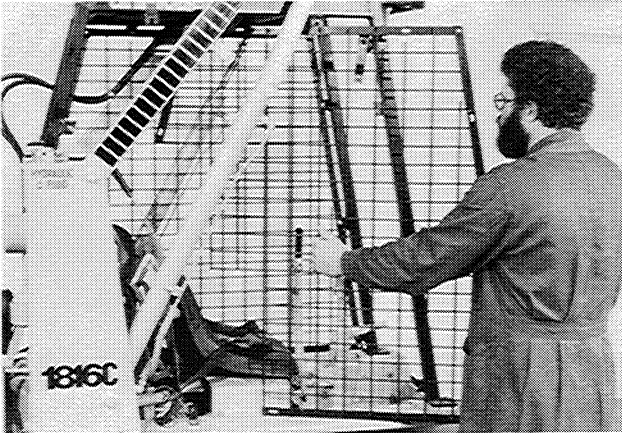

Figure 1

6. Remove the seat from the machine.

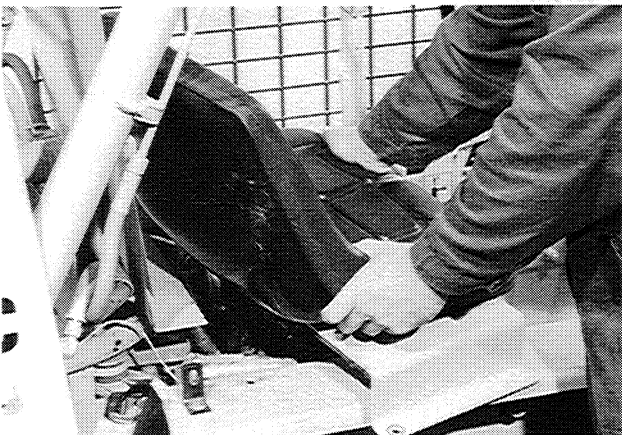
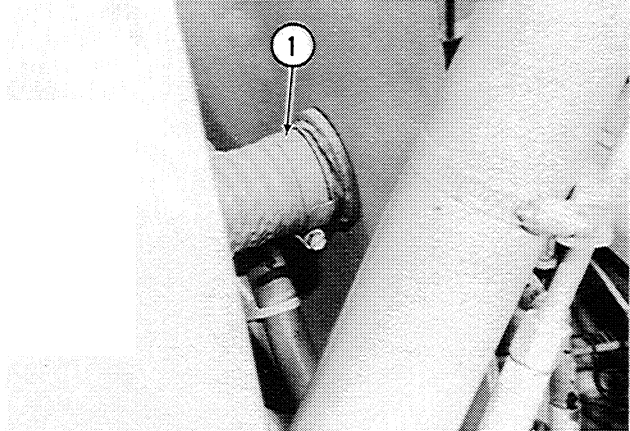

Figure 2

7. Loosen the clamp which fastens the air inlet hose to the tube in the heat shield. Disconnect the air inlet hose from the tube. Put the air inlet hose out of the way.



1. Clamp

Figure 3

8. Remove the heat shield from the machine.



Figure 4

9. Remove the RH floor plate from the machine.

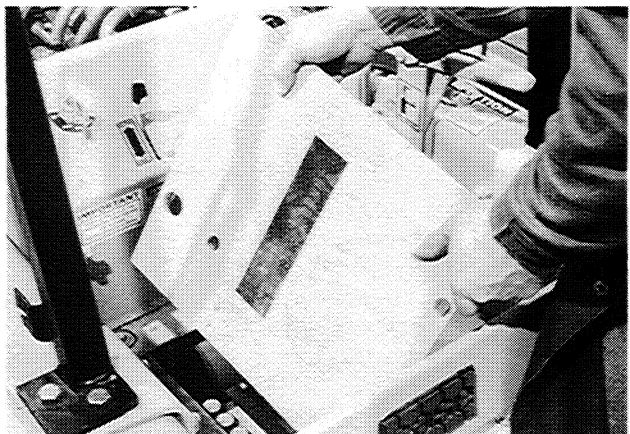
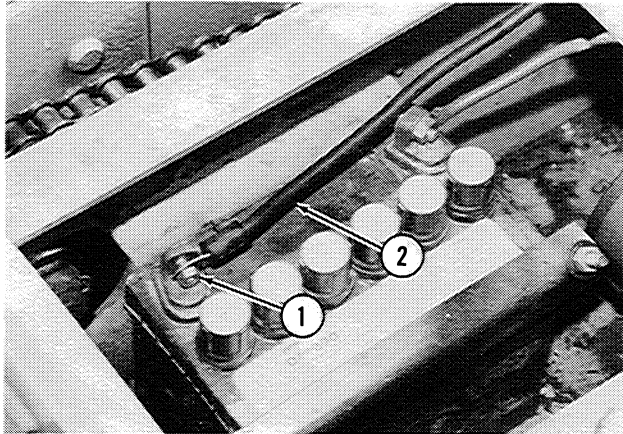

Figure 5

10. Remove the nut which fastens the negative (ground) cable to the battery.



- 1. Nut
- 2. Negative (Ground) Cable

Figure 6

11. Disconnect the negative (ground) cable from the battery.



Figure 7

12. Remove the bolts and the self-locking nuts which fasten the rear grille to the RH side of the machine frame. Push the rear grille to the left as far as possible.

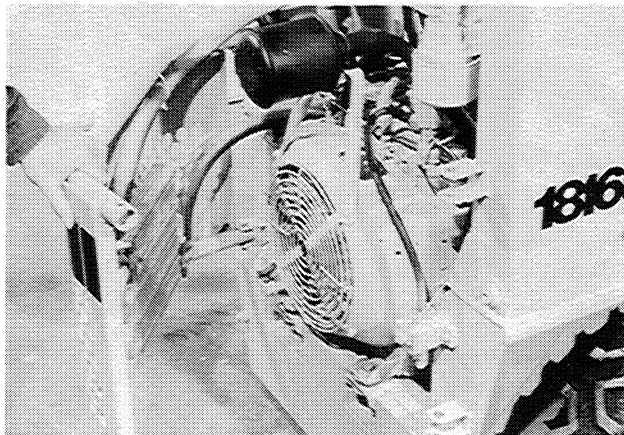

Figure 8

13. Remove the oil drain cap and drain the oil from the engine.

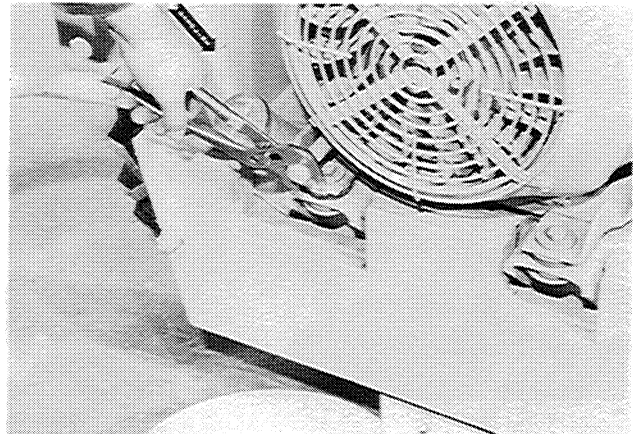

Figure 9

14. When all of the oil is drained, install the oil drain cap on the engine.



Figure 10

15. Loosen the clamps which fasten the tube between the air cleaner and the carburetor.

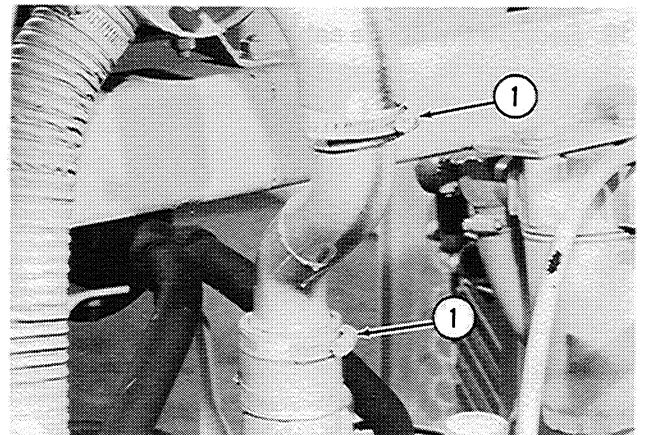

- 1. Clamp

Figure 11

16. Remove the tube from the machine.

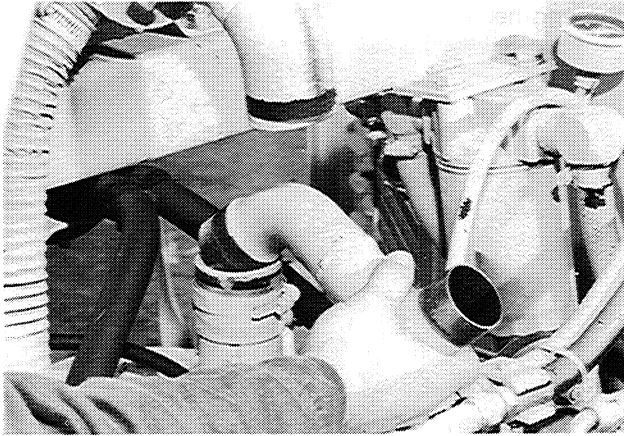
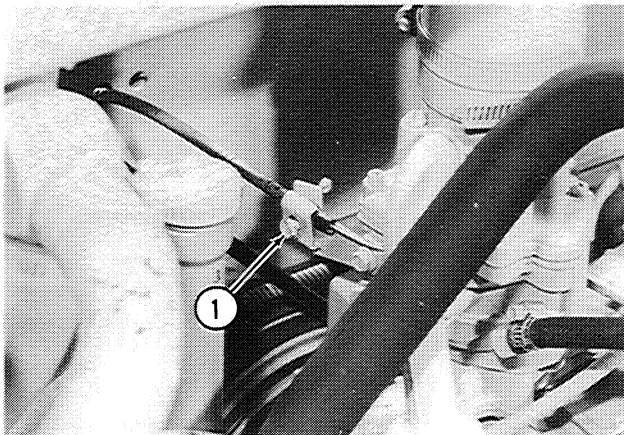

Figure 12

17. Put covers over the carburetor inlet and over the hose on the air cleaner inlet so that no dirt can enter these parts.

18. Loosen the screw which fastens the choke cable in the clamp at the side of the carburetor.



1. Screw

Figure 13

19. Remove the choke cable from the clamp.

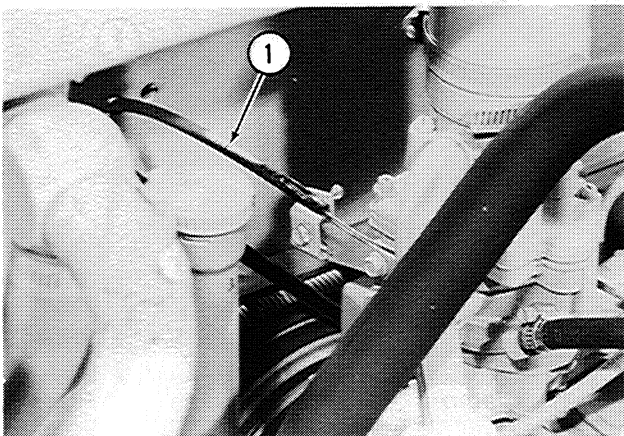

1. Choke Cable

Figure 14

20. Disconnect the end of the choke cable from the choke lever on the side of the carburetor.

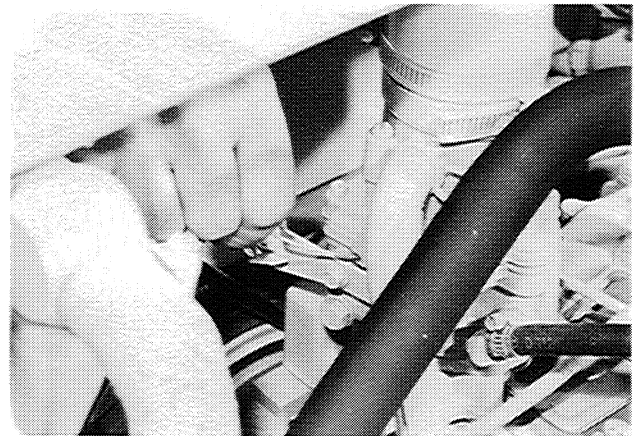
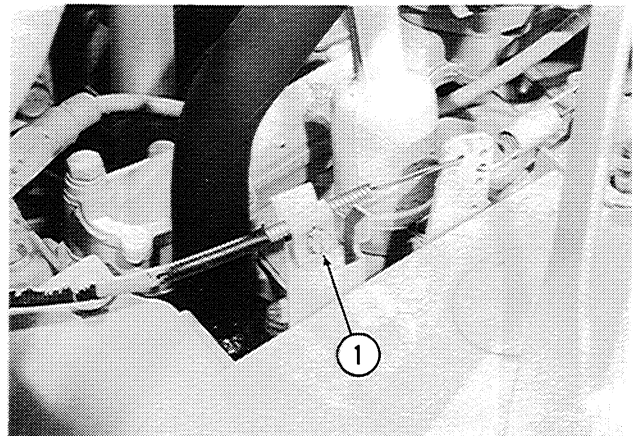

Figure 15

21. Loosen the screw which fastens the throttle cable in the clamp on the flywheel housing of the engine.



1. Screw

Figure 16

22. Remove the throttle cable from the clamp.

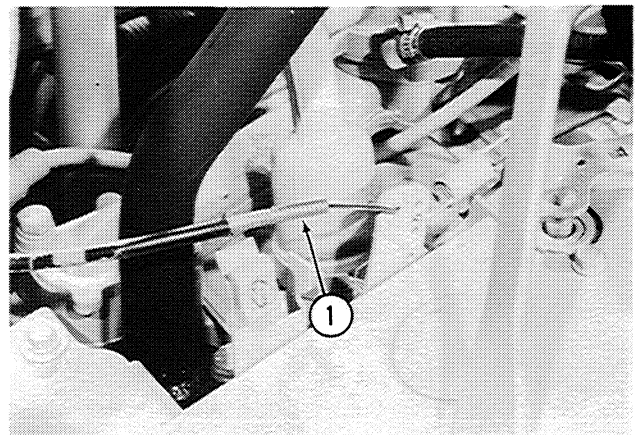

1. Throttle Cable

Figure 17

23. Disconnect the end of the throttle cable from the governor linkage on the flywheel housing.

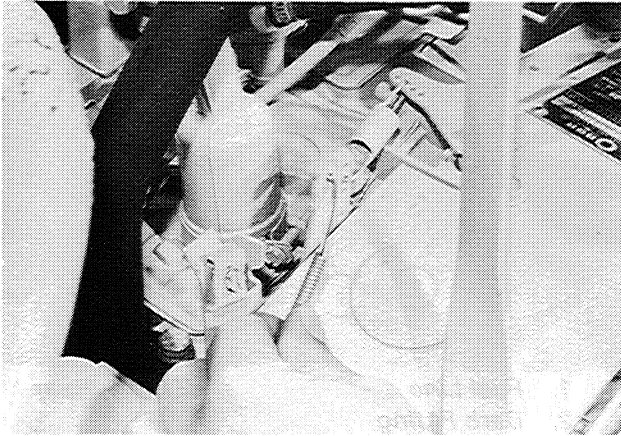

Figure 18

25. Remove the rubber cover from the rear terminal of the ignition coil.

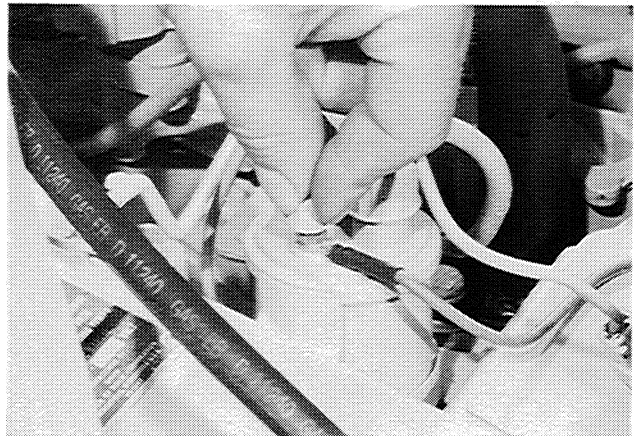
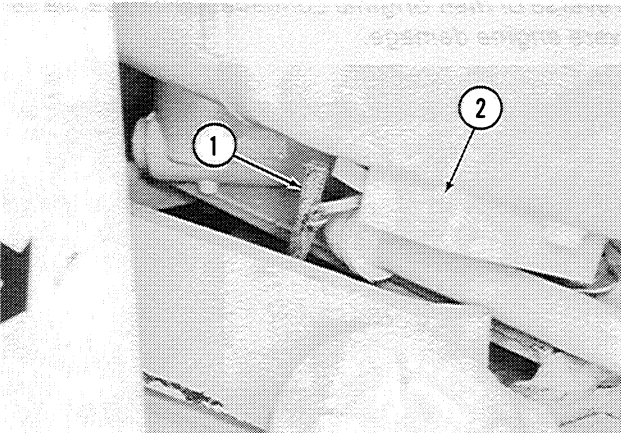

Figure 21

24. Disconnect the ammeter wire from the voltage regulator on the bottom LH side of the flywheel housing. The ammeter wire is the bottom wire of the three wires connected to the voltage regulator.



- 1. Ammeter Wire
- 2. Voltage Regulator

Figure 19

26. Loosen the nut on the rear terminal.

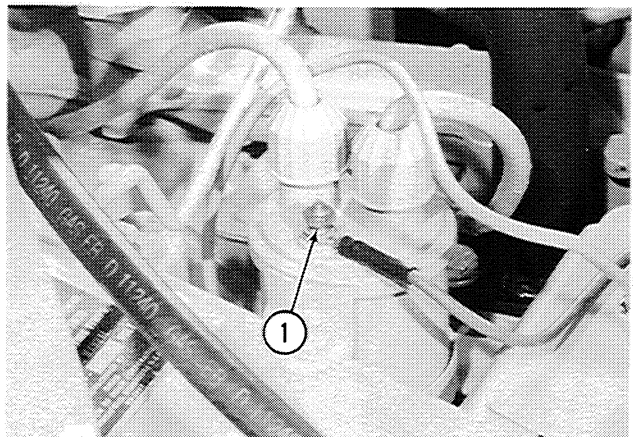

- 1. Nut

Figure 22

27. Disconnect the wire from the rear terminal.

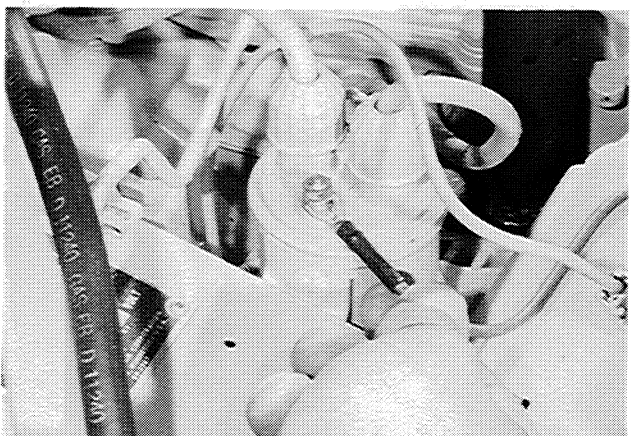
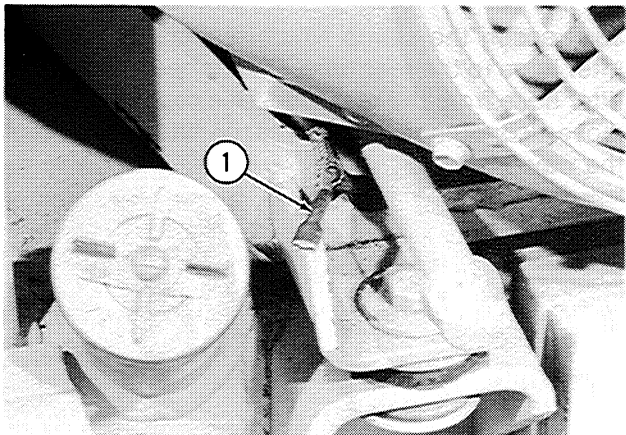

Figure 23



- 1. Ammeter Wire Disconnected

Figure 20

28. Disconnect the oil pressure sender wire at the connector near the wiring clamp on the RH air housing.

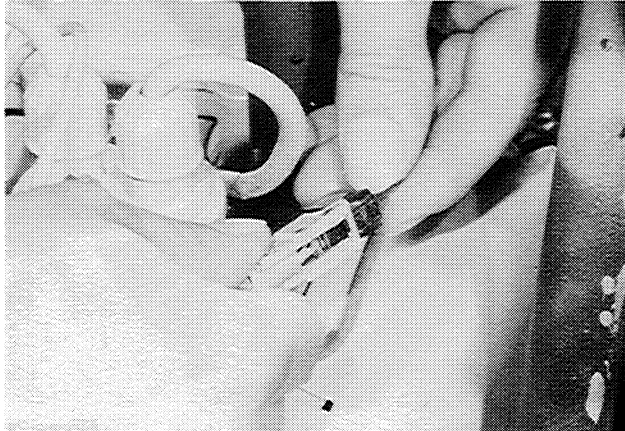
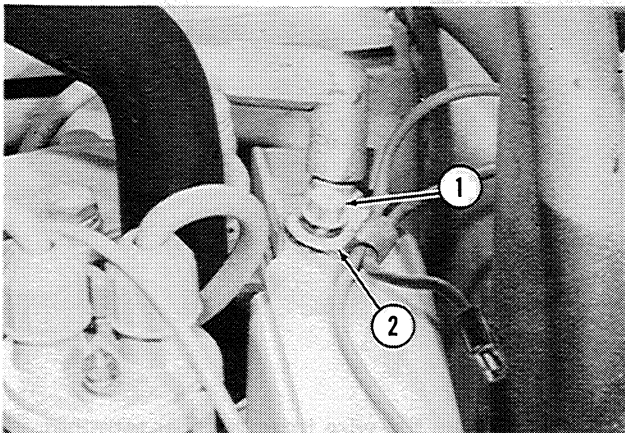

Figure 24

29. Remove the cap screw and the flat washer which fasten the wiring clamp and the RH air housing to the engine. Put the wiring clamp and the wires out of the way.



- 1. Cap Screw
- 2. Flat Washer

Figure 25

30. Loosen the clamp which fastens the fuel line to the barb fitting on the carburetor.

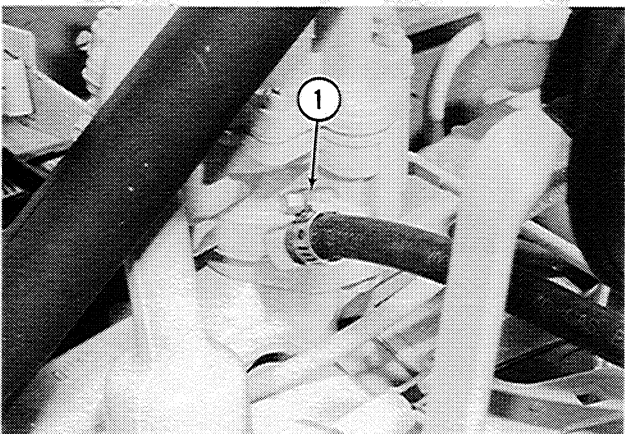

- 1. Clamp

Figure 26

31. Disconnect the fuel line from the barb fitting.

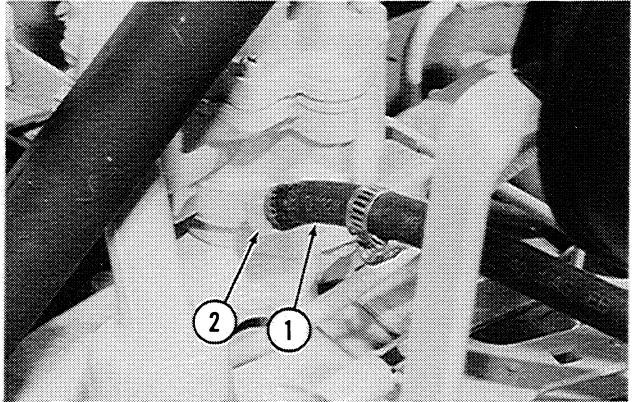

- 1. Fuel Line
- 2. Barb Fitting

Figure 27

32. Install identification tags on the oil filter hoses so that the oil filter hoses will be installed correctly.

**NOTE:** Be sure to use identification tags on the oil filter hoses. Connecting the oil filter hoses in the reverse of their original connections can cause severe engine damage.



Figure 28

33. Loosen the clamp which fastens the rear oil filter hose to the rear tube. Disconnect the rear oil filter hose from the rear tube. Use caps or plugs to close all openings. Put the rear oil filter hose out of the way.

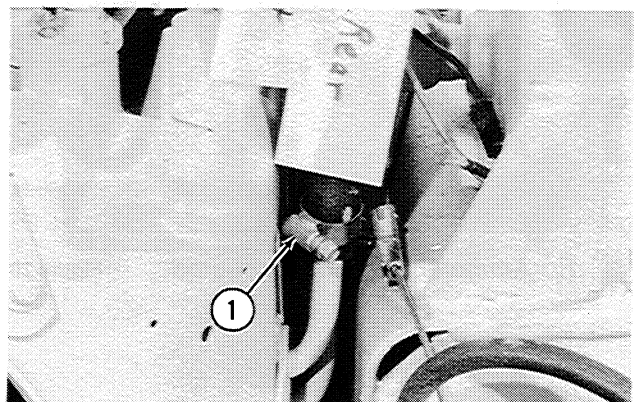

- 1. Clamp

Figure 29

34. Loosen the clamp which fastens the front oil filter hose to the front tube. Disconnect the front oil filter hose from the front tube. Use caps or plugs to close all openings. Put the front oil filter hose out of the way.

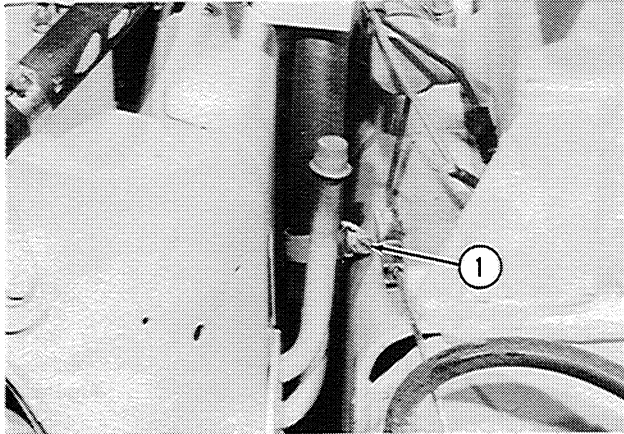

1. *Clamp*

Figure 30

35. Loosen the mounting bolts for the equipment pump until the equipment pump sheave can be moved toward the center of the machine. Push the equipment pump sheave toward the center as far as possible.

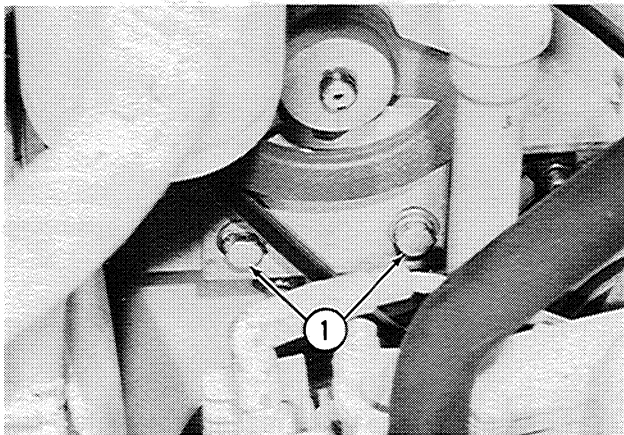

1. *Mounting Bolt*

Figure 31

36. Remove the drive belt for the equipment pump from the equipment pump sheave.

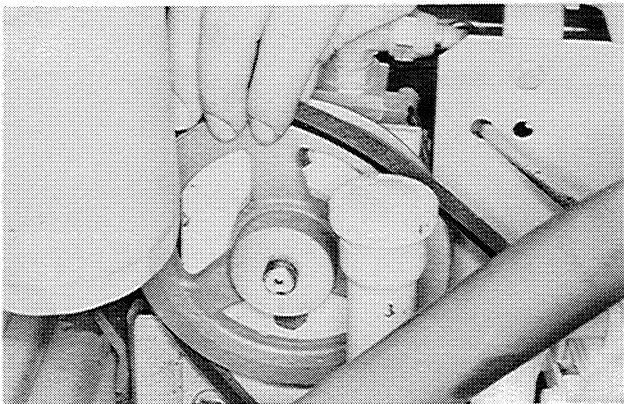
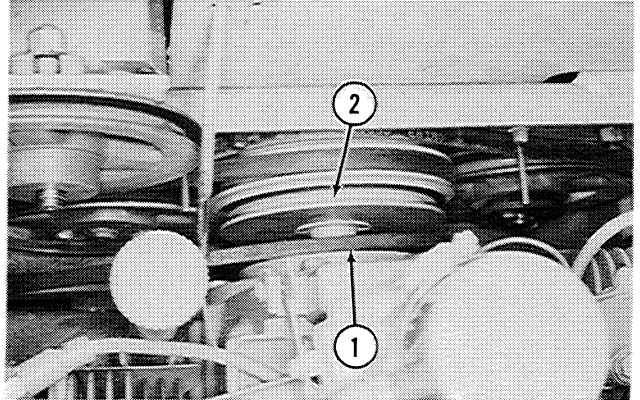

Figure 32

37. Remove the drive belt for the equipment pump from the groove in the drive sheave on the engine. Put the drive belt to the rear of the drive sheave.



1. *Drive Belt*  
2. *Drive Sheave*

Figure 33

38. Remove the drive belt for the LH piston pump from the sheave on the LH piston pump.

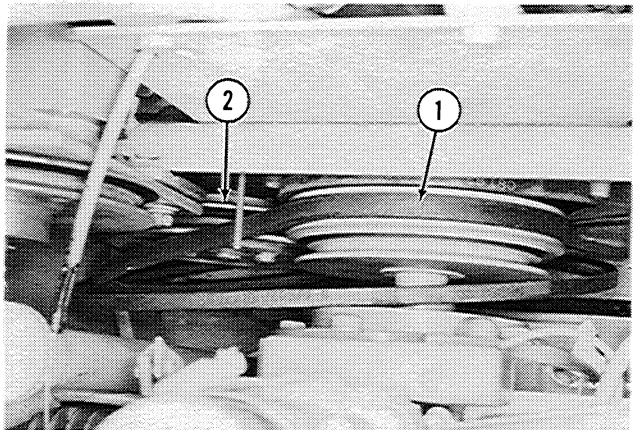

1. *Drive Belt*  
2. *Sheave on LH Piston Pump*

Figure 34

39. Remove the drive belt for the RH piston pump from the sheave on the RH piston pump.

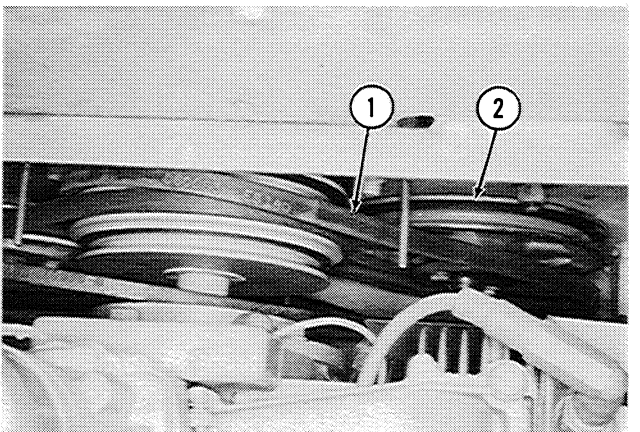

1. *Drive Belt*  
2. *Sheave on RH Piston Pump*

Figure 35

40. Remove the nut which fastens the cable to the battery terminal on the starter.

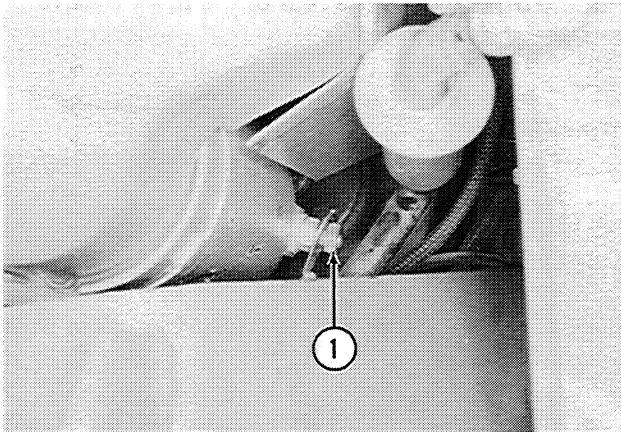

1. Nut

Figure 36

41. Disconnect the cable from the battery terminal.

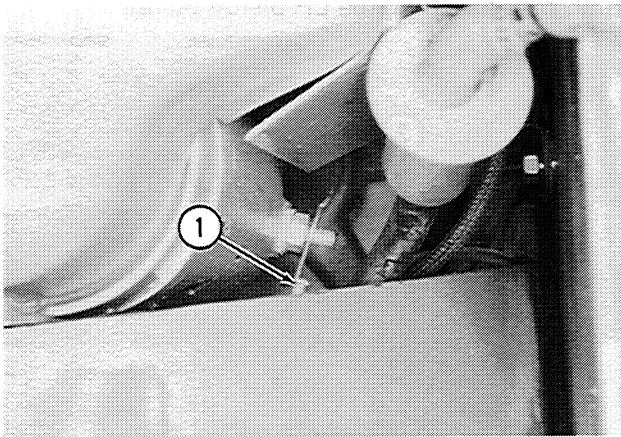

1. Cable

Figure 37

42. Push the drive belts to the front of the drive sheave to get access to the two cap screws which fasten the front of the engine to the mounting plate. Remove the two cap screws, the lock washers, and the flat washers.

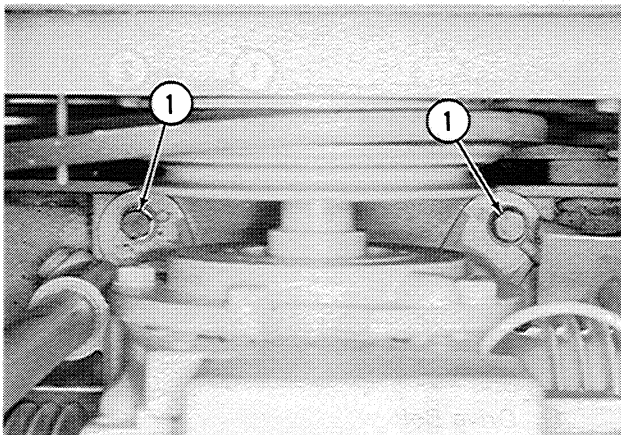

1. Cap Screw

Figure 38

43. The RH cap screws holds two ground wires. Make sure that these ground wires are installed on the RH cap screw during Assembly.

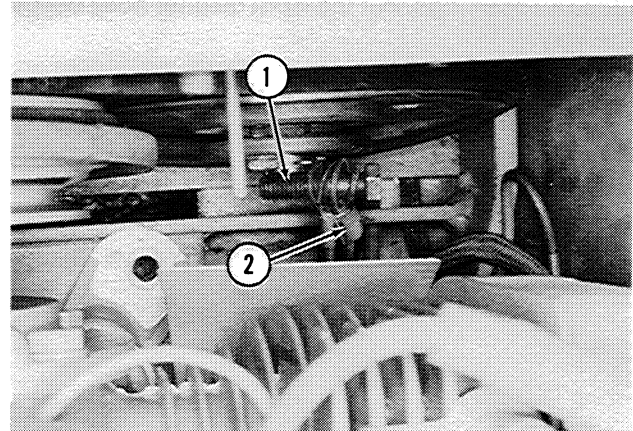

1. RH Cap Screw

2. Ground Wires

Figure 39

44. Remove the two flange head screws which fasten the rear of the engine to the mounting plate.

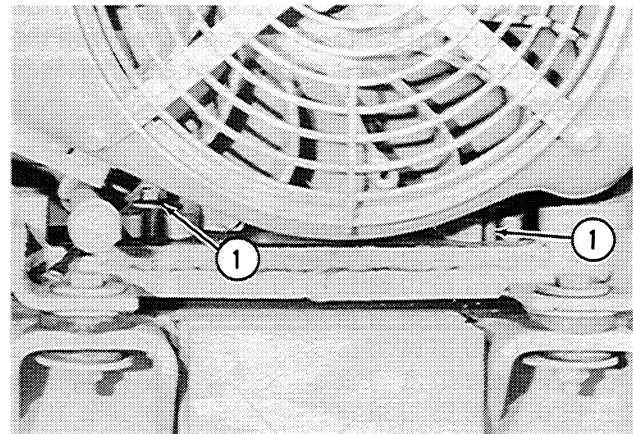

1. Flange Head Screw

Figure 40

45. Move the engine to the rear approximately two inches (51 mm). Remove the drive belts from the drive sheave.

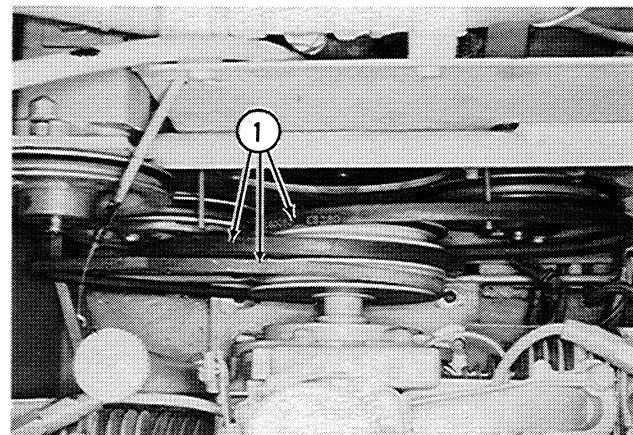

1. Drive Belts

Figure 41



**Suggest:**

**If the above button click is invalid.**

**Please download this document**

**first, and then click the above link**

**to download the complete manual.**

**Thank you so much for reading**

46. Connect acceptable lifting equipment to the engine. Engine weight is approximately 100 pounds (45 kg). Lift the engine from the machine.

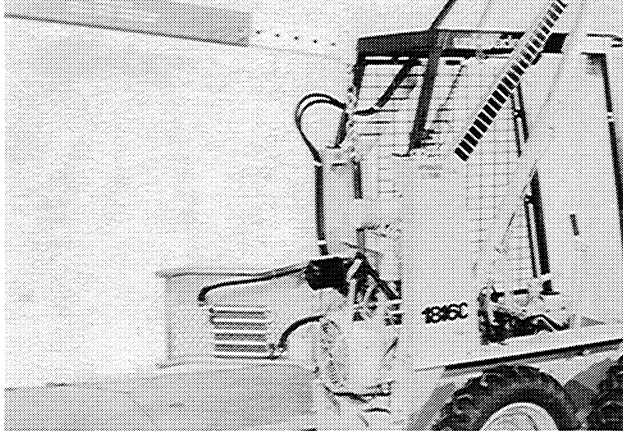

Figure 42

## ENGINE INSTALLATION

Engine installation is the reverse of engine removal. See Section 9003 for correct torques when installing the seat. See Section 6012 for correct installation and adjustment of the drive belts.

**NOTE:** *Make sure that the drive belts for the piston pumps are installed between the top and the bottom belt guides on the pump mounting plate.*

**<https://www.ebooklibonline.com>**

Hello dear friend!

Thank you very much for reading.

Enter the link into your browser.

The full manual is available for immediate download.

**<https://www.ebooklibonline.com>**