

1. Trim along dashed line.
2. Slide into pocket on Binder Spine.

TYPE 1-4

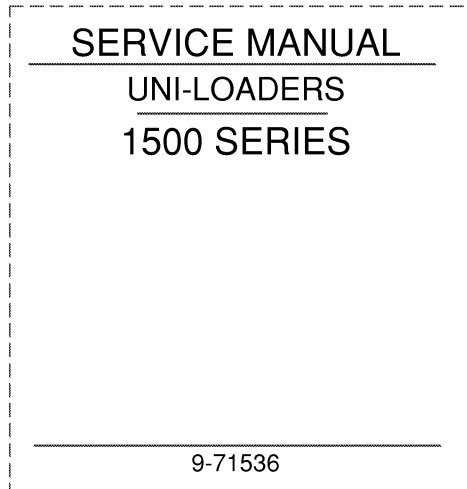

1. Trim along dashed line.
2. Slide into pocket on Binder Spine.

TYPE 1-4

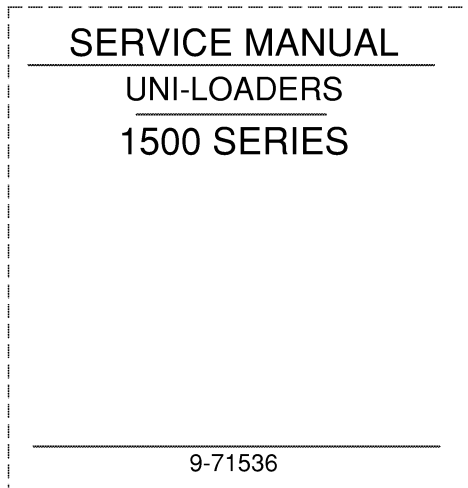

1. Trim along dashed line.
2. Slide into pocket on Binder Spine.

TYPE 1-4

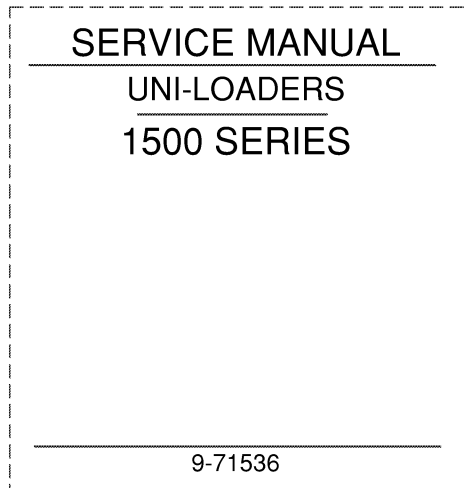

1. Trim along dashed line.
2. Slide into pocket on Binder Spine.

TYPE 1-4

1500 SERIES UNI-LOADERS

TABLE OF CONTENTS

SECTION	SECTION NO.	FORM NO.
GENERAL		
Maintenance and Lubrication	13	9-71535
ENGINE		
Air Cleaner	24	9-71535
<p>NOTE: Manuals for the Wisconsin engines are supplied by the Wisconsin Motor Division of the Continental Motors Corporation.</p>		
FUEL SYSTEMS		
Electric Fuel Pump	34	9-71535
<p>NOTE: For carburetor information, refer to the service manual for the Wisconsin engine.</p>		
LP Gas Fuel System	37	9-71535
HYDRAULICS		
Hydraulic System	41	9-71535
Hydraulic System	41, Supp. 1	9-71536
<p>NOTE: Supplement 1 for Section 41 incorporates changes and improvements made to the machine after printing of Section 41. Following are the major areas of change:</p> <ol style="list-style-type: none"> a. Updated pressure checks and troubleshooting procedures. b. Updated specifications and hydraulic diagrams. c. 3-spool control valve with new plunger-type relief valve. d. Variable speed control valve with new thermal relief valve. e. New TRW hydraulic pump. 		
POWER TRAIN		
Power Train	61	9-71536
BRAKES		
Brakes	72	9-72095
ELECTRICAL		
Electrical System	82	9-71535
MOUNTED EQUIPMENT		
Loader	92	9-71535
Loader	92, Supp. 1	9-71536
<p>NOTE: Supplement 1 for Section 92 incorporates changes and improvements made to the machine after printing of Section 92.</p>		
Rollover Protection Structure	9019	9-71535

Section 13

MAINTENANCE AND LUBRICATION

<https://www.ebooklibonline.com>

Hello dear friend!

Thank you very much for reading.

Enter the link into your browser.

The full manual is available for immediate download.

<https://www.ebooklibonline.com>

MAINTENANCE CHART

Model 1526

INTERVAL	SERVICE	FLUID/LUBRICANT	INSTRUCTIONS
Run-In After First 20 Hours	Change engine oil and clean engine oil filter. Check valve clearance.	See chart, page 4.	See engine manual. See engine manual.
Run-In After First 60 Hours	Change engine oil and clean engine oil filter.	See chart, page 4.	See engine manual.
Every 10 Hours Or Daily	Check engine oil level.		See engine manual.
Every 120 Hours	Change engine oil and clean engine oil filter. Check valve clearance.	See chart, page 4.	See engine manual.
Every 240 Hours	Check generator drive belt tension. Clean fuel filter.		See engine manual. See engine manual.
Every 600 Hours	Clean and test fuel injection. Lubricate starter motor. Check generator operation.	Engine oil.	See engine manual. See engine manual.
Every 1000 Hours	Clean starter motor. Lubricate flywheel ring gear.		See engine manual. See engine manual.
As Required	Clean engine cooling fins.		See engine manual.

Model 1530 & 1537

Every 10 Hours Or Daily	Check engine oil level.		See engine manual.
Every 50 Hours	Change engine oil. Lubricate distributor.	See chart, page 4. 3 to 5 drops engine oil.	See engine manual.
Every 100 Hours	Change engine oil filter.		See engine manual.
As Required	Clean fuel sediment bowl. Clean engine cooling fins.		See engine manual.
At Engine Or Starter Overhaul	Lubricate starter.	#2 lithium-soap base grease.	See engine manual.

Inspect filter after it is clean and dry. Place a light inside filter and inspect for holes, tears, and dented or bent metal covering. If metal covering is dented or bent, inspect filter paper for holes or rub spots in that area. If holes or rub spots are noted, discard filter and install new filter element.

NOTE: Inspect new filter element for defects in the same manner. Do not accept a defective filter.

The filter must be replaced after it has been cleaned six times or once a year, whichever ever occurs first.

OPTIONAL AIR CLEANER

Filter service consists of replacing the filter element when the red band on the restriction indicator remains in view. In

addition to replacing the filter element, wipe out the filter housing with a damp, lint free cloth and clean the pre-cleaner.

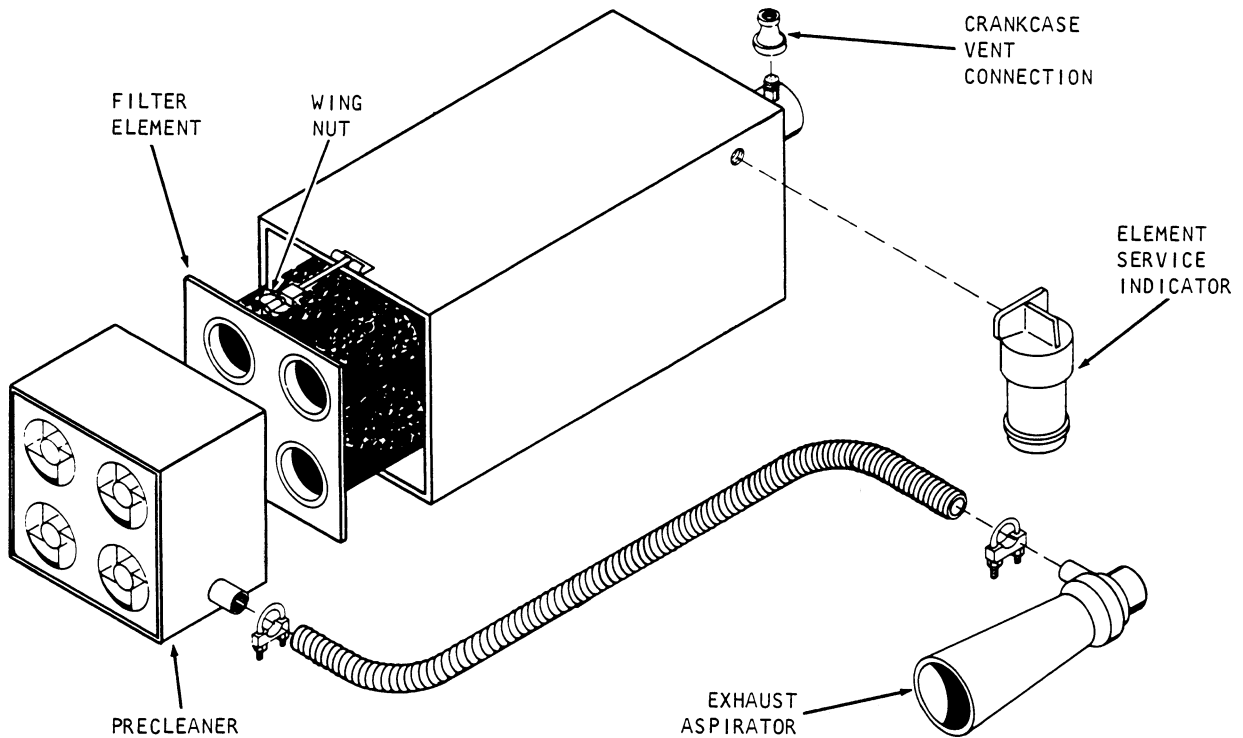

Figure 3 - Exploded View of Air Cleaner

Section 24

AIR CLEANER

STANDARD AIR CLEANER

Service Interval

The service interval is self determined, taking into consideration working conditions. It is only natural that the filter element be serviced more often when the machine is operated in a dusty or sandy atmosphere. In addition to element service, the dust cup should be cleaned daily or more often as conditions warrant.

Filter Element Service

The preferred method of cleaning the filter is by washing. Washing the filter results in restoring the filter to an almost new condition and longer intervals between servicing. It is recommended that a spare filter be available to allow sufficient drying time for the serviced filter and to reduce machine downtime.

Wash the filter in Case Filter Element Cleaner (Part No. A40910) according to instructions on container. Rinse thoroughly. Do not use water pressure over 40 psi at

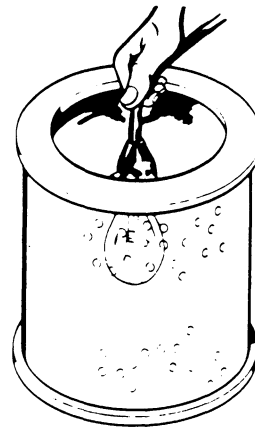

Figure 1 - Inspecting The Element

nozzle. Set filter aside to dry. Do not use compressed air to dry.

Use of compressed air to clean the filter is permissible but not recommended as it does not remove carbon and soot. When using compressed air, use no more than 100 psi at nozzle and keep nozzle a reasonable distance away from filter.

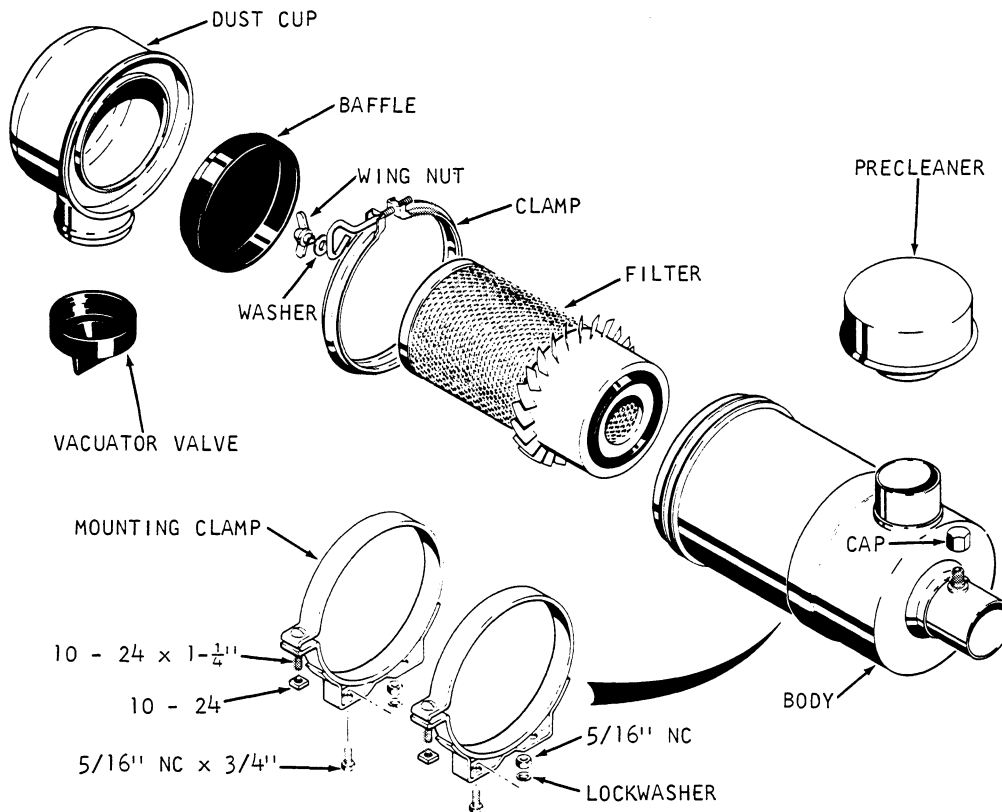

Figure 2 - Exploded View of Air Cleaner

All Models

INTERVAL	SERVICE	FLUID/LUBRICANT	INSTRUCTIONS
Run-In Every 2 Hours	Check wheel bolt torque until stable. (85-100 ft. lbs.)		
Run-In After First 15 Hours	Replace hydraulic oil filter.		Section 41.
Every 10 Hours Or Daily	Grease the loader pivot points. Clean the air cleaner dust cup.	See chart, page 4.	
Every 20 Hours Hours	Grease variable speed pulleys. (Three strokes each fitting).	See chart, page 4.	
Every 25 Hours Severe Service	Check and adjust drive chains.		Section 61.
Every 50 Hours Normal Service	Check and adjust drive chains.		Section 61.
Every 60 Hours	Check battery electrolyte level. Check hydraulic oil level. Check tire pressure.	Distilled water.	Section 82. Section 41.
Every 120 Hours	Grease drive shaft universals. Check gear box oil level.	See chart, page 4.	Section 61.
Every 500 Hours	Replace or clean electric fuel pump filter. Change hydraulic oil. Replace hydraulic oil filter.	Case TCH Fluid.	Section 34. Section 41. Section 41.
Every 1000 Hours	Clean hydraulic reservoir breather and filler cap. Drain water from fuel tanks.		Section 41.
Every 2000 Hours Or Yearly	Change gear box oil. Replace fuel filter element (LP gas machines only).	See chart, page 4.	Section 61.
As Required	Clean or replace air cleaner element. Replace hydraulic filter. Check wheel bolt torque (85-100 ft. lbs.) Adjust clutches when lever travel exceeds 6" from neutral.		Section 24. Section 41. Section 61.

LUBRICANT CHART

ITEM	CAPACITIES		RECOMMENDATIONS
	U. S.	METRIC	
Model 1526 Engine crankcase	6-1/4 qts.	6 liters	Use engine oil meeting the following specifications: (Normal conditions) CA Commercial Class A (DG) (MIL-L-2104A, Supp. 1) (Extreme conditions) CB Commercial Class B Above 68° F. SAE 30 (20° C) 68° F. to -14° F. . . . SAE 20/20W (20° C to -10° C) NOTE: For continuous full load duty, use SAE 30 oil.
Model 1530 Engine crankcase Without filter change	3-1/2 qts.	3,3 liters	Use engine oil meeting the following specifications: SD Service Class D (MS)
With filter change	4 qts.	3,8 liters	120° F. to 40° F. SAE 30 (49° C to 4° C)
Model 1537 Engine crankcase Without filter change	4-1/2 qts.	4,3 liters	40° F. to 15° F. SAE 20-20W (4° C to -9° C)
With filter change	5 qts.	4,7 liters	15° F. to 0° F. SAE 10W (-9° C to -18° C) Below 0° F. SAE 5W - 20W (-18° C)
Gear box (all machines)	1-1/2 pts.	0,7 liters	Multipurpose gear lubricant SAE 90 EP--Case Part No. B53983 API-GL-4 with low foaming additive.
Hydraulic reservoir refill capacity	14 gal.	53 liters	Case TCH fluid.
Hydraulic system capacity (approx.)	19 gal.	72 liters	Case TCH fluid.
Fuel tanks (combined) 1526 & 1537 1530	17 gal. 12 gal.	64 liters 45 liters	
Grease fittings	As required.		Above 32° F. (0° C) use Multipurpose or No. 2 lithium-soap base grease. Below 32° F. (0° C) use Multipurpose or No. 1 lithium-soap base grease.

NOTE: Automatic transmission oil Type A Suffix A may be used as an alternate oil for Case TCH Fluid.

Section 34

ELECTRIC FUEL PUMP

ELECTRIC FUEL PUMP

Description And Operation

NOTE: Servicing and parts replacement is limited to the parts shown in Figure 1. If an electrical component fails, the pump must be replaced.

The electric fuel pump is designed with a solenoid which, when energized, causes the movement of a hollow plunger in a cylindrical bore. The plunger stroke is controlled by a set of interrupter type contact points in the pump electrical circuit. The contact points function in a sealed section containing an inert gas for long point life.

Upon energization of the solenoid, the plunger is forced down in the cylinder against the plunger spring which is seated on a closed check valve in the bottom of the bore. A check valve in the plunger opens permitting passage of the trapped fuel through the plunger.

On the opening of the contacts the solenoid is de-energized; the plunger spring returns the plunger to the top of the bore at a fixed rate to provide the required pressure. During the upward movement of the plunger, the check valve in the plunger is closed to move the fuel ahead of it into the fuel system and the check valve in the bottom of the bore is open to permit passage of fuel into the cylinder for the next cycle.

A pulsation dampener in the top of the pump provides steady operation and even pressure. The pump also incorporates a pressure relief system to assure an immediate return to zero fuel pressure when the ignition is turned off.

The filter system is contained in the lower portion of the pump and consists of a filter and magnet.

Removal

1. Disconnect the inlet and outlet fuel lines at the fuel pump. Secure inlet line as high as possible to prevent fuel tank drainage.
2. Disconnect the wire at the connector in the fuel pump lead.

3. Remove the fuel pump mounting nuts and lockwashers. Remove fuel pump.

Disassembly

Refer to Figure 1.

1. Use a wrench to turn bottom cover from bayonet pins. Twist cover by hand to remove from pump body.
2. Remove filter, magnet and cover gasket.
3. Remove retainer spring using a thin nose pliers to spread and remove the ends of the retainer from plunger tube.
4. Remove washer, o-ring, cup valve, plunger spring and plunger.

Inspection

1. Wash the filter in cleaning solvent and blow out dirt and cleaning solvent with compressed air. Check cover gasket and replace if deteriorated. Clean the cover.
2. Clean the remainder of the removed parts in cleaning solvent. If the plunger does not wash clean or if there are any rough spots, gently clean the surface with crocus cloth. Shake plunger and listen for click to indicate valve action. If valve is not free, replace plunger assembly.

CAUTION: The buffer spring and valve must not be removed from plunger.

3. Slosh the pump assembly in cleaning solvent. Blow out the tube with compressed air. To do a complete job, swab the inside of the tube with a cloth wrapped around a stick.

CAUTION: Do not tamper with seal at center of mounting bracket at side of pump as it retains the dry gas which surrounds the electrical system in the upper portion of the pump.

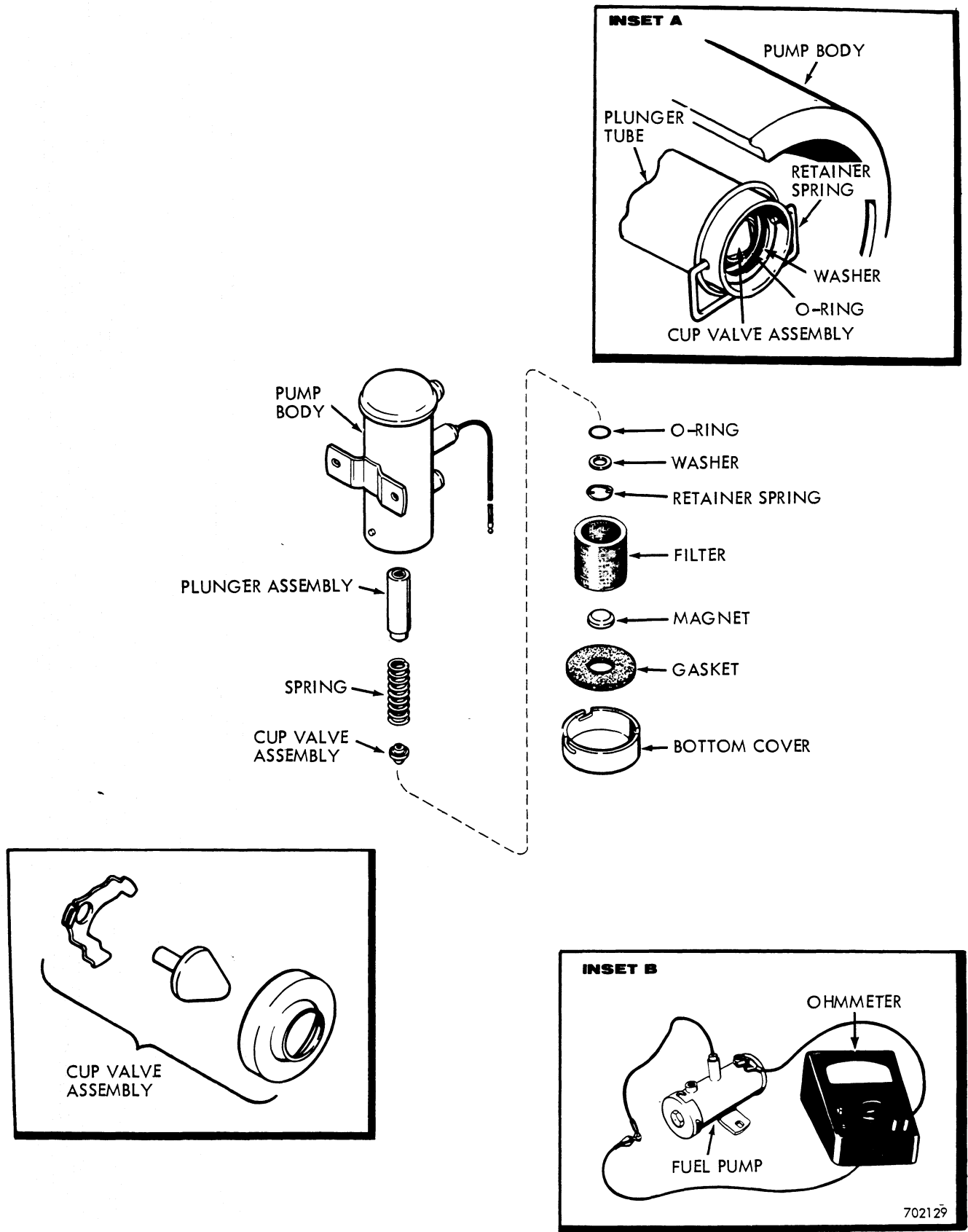

Figure 1 - Exploded View of Electric Fuel Pump

Assembly

1. Install the plunger assembly in the tube with the buffer spring end first. Check by slowly raising and lowering plunger in tube. Plunger should move freely without a tendency to stick. A click will be heard each time the plunger approaches the top of the tube. If a click cannot be heard, the interrupter assembly is not functioning properly. Replace pump.
2. Install plunger spring, cup valve, o-ring and washer.
3. Compress spring and install the retainer spring with ends of retainer inside holes of tube, inset A.
4. Place cover gasket and magnet in bottom cover. Then install filter and cover. Twist cover by hand to hold in position on pump housing. Use wrench to securely tighten cover.
5. Prior to installing the pump, check the resistance of the pump winding. Connect the fuel pump to a 12 volt battery (negative lead to pump body) for two seconds. Connect ohmmeter to fuel pump. The ohmmeter should indicate 4.87 to 12 ohms. If infinite (no needle movement), reconnect pump to battery for two seconds and recheck resistance. If still infinite, replace pump.

Installation

1. Position pump on mounting studs and secure in place with nuts and lock-washers. Make sure mounting surface is clean and paint-free as the pump is grounded at this point.
2. Connect fuel lines and wire.
3. Open fuel shutoff valve.
4. Bleed the fuel system.

Section 37

L. P. GAS FUEL SYSTEM

L. P. FUEL SYSTEM

NOTE: For additional information contact an authorized Wisconsin Engine dealer.

General

The major components of the L.P. fuel system are the fuel cylinder, fuel filter (with lock-off), converter and carburetor (with vacuum operated lock-off switch). The carburetor is deprived of fuel until the ignition switch is turned on and the engine is cranked for starting. If the engine stops for any reason, the carburetor is again deprived of fuel.

Liquid fuel flows from the fuel cylinder, under pressure thru the fuel filter to the converter. Two changes occur at the converter; (1) the converter acts as a heat exchanger and vaporizes the fuel and (2) regulates the pressure of the fuel vapor delivered to the carburetor. The carburetor receives fuel from the converter relative to the quantity of air entering the carburetor.

Fuel

If available, use Propane HD 5 in place of commercial propane. Propane HD 5 was developed especially for internal combustion engines.

Pressure in a fuel cylinder 80% full will be approximately 100 psi at 70° F. An increase in temperature will increase pressure while lower temperatures will reduce pressure.

Fuel pressure at the carburetor is 1.25 psi at idle speed and 1.75 psi at full throttle.

Carburetor Adjustments

Idle Adjustments

Refer to Figure 1.

1. Seat idle mixture screw and back off four turns.

CAUTION: Seat screw lightly to prevent damage to the screw and seat.

2. Start engine and turn throttle stop screw so engine idles slightly faster than normal.
3. Turn idle mixture screw in until engine begins to stall, then back off screw until engine runs smoothly.

NOTE: If vacuum gauge is available, adjust to obtain highest manifold vacuum.

4. Back off throttle stop screw to obtain desired idle speed.

Power Valve Adjustment

The power valve should rarely require adjustment. If adjustment is necessary, position the mark on the adjusting screw between 2 and 3 on the power valve dial, Figure 1.

If an exhaust analyzer is available a more accurate adjustment can be made. Run engine at full throttle and adjust power valve to obtain an air/fuel ratio of 14 to 1.

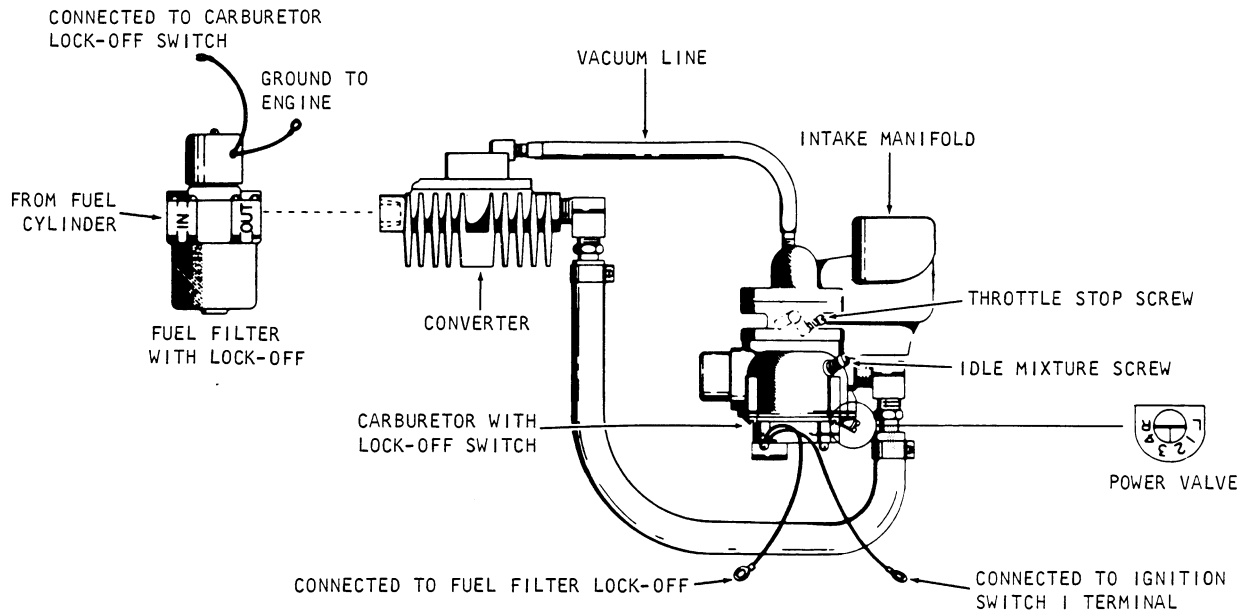

1530 FUEL SYSTEM

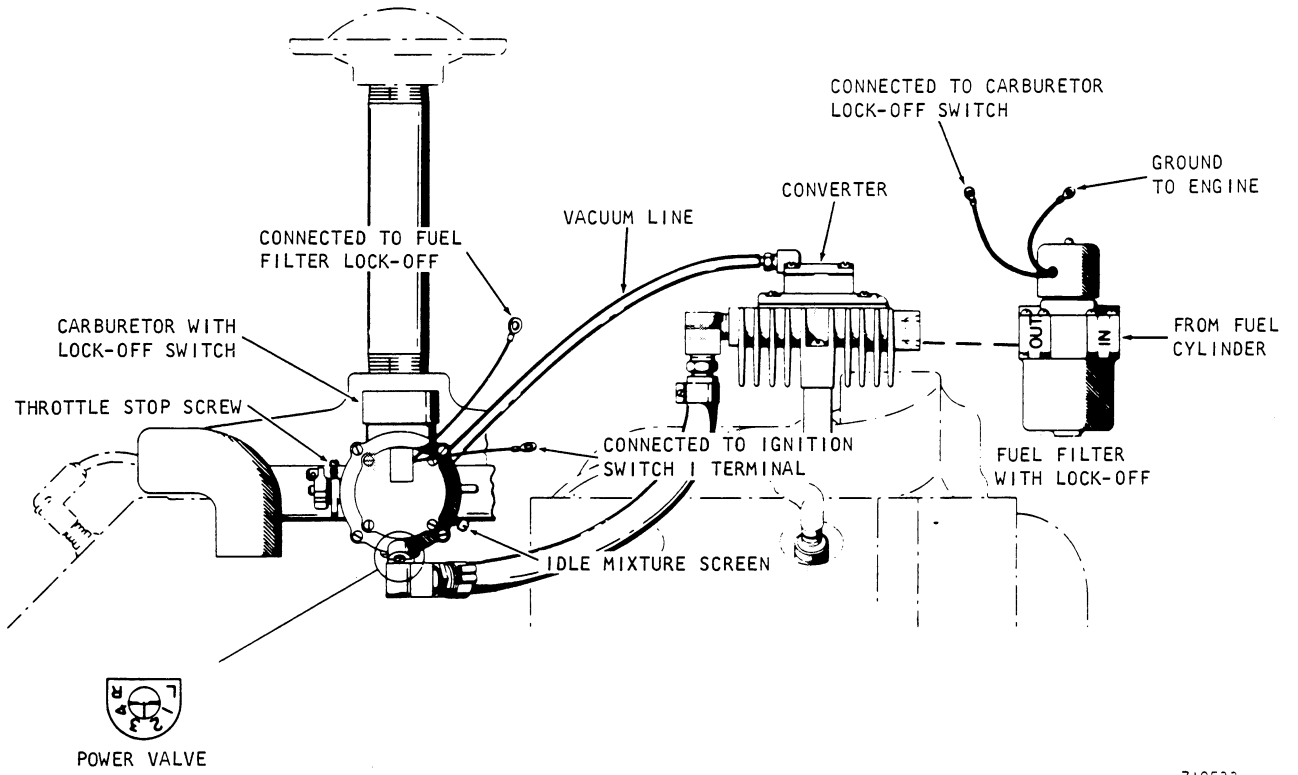

1537 FUEL SYSTEM

Figure 1 - Fuel Systems

710533

TROUBLE SHOOTING CHART

<u>PROBLEM</u>	<u>POSSIBLE CAUSE</u>	<u>REMEDY</u>
Engine Will Not Start	<ol style="list-style-type: none"> 1. Defect in ignition system. 2. Fuel cylinder empty. 3. Fuel shut-off valve closed. 4. Excess flow valve closed. 5. Restricted fuel filter. 6. Defective lock-off switch. 7. Defective lock-off switch diaphragm. 8. Defective lock-off solenoid. 9. Broken wire in lock-off circuit. 	<ol style="list-style-type: none"> 1. Check out ignition system. 2. Refill cylinder. 3. Open valve. 4. Close fuel shut-off valve and listen for click. Then open valve slowly. 5. Service filter. 6. Replace switch. 7. Replace diaphragm. 8. Replace solenoid. 9. Repair as required.
Frost on Fuel Filter	<ol style="list-style-type: none"> 1. Fuel shut-off valve opened too fast. 2. Restricted fuel filter. 	<ol style="list-style-type: none"> 1. Open valve slowly. See NOTE. 2. Service filter.
Frost on Line Between Carburetor And Converter	<ol style="list-style-type: none"> 1. Fuel not vaporizing. 	<ol style="list-style-type: none"> 1. Allow engine to warm up thoroughly.
Frost at Connections	<ol style="list-style-type: none"> 1. Leak or restriction at frosted area. 	<ol style="list-style-type: none"> 1. Check for leaks or restriction. USE A SOAP SOLUTION TO CHECK FOR LEAKS.
Frost at Converter, Engine Running	<ol style="list-style-type: none"> 1. Engine and converter not warmed up. 	<ol style="list-style-type: none"> 1. Allow engine to warm up thoroughly.
Frost at Converter, Engine Stopped	<ol style="list-style-type: none"> 1. Fuel not shut off at filter. 	<ol style="list-style-type: none"> 1. Check lock-off circuit.
Frost on Fuel Cylinder	<ol style="list-style-type: none"> 1. Broken dip tube in cylinder. 	<ol style="list-style-type: none"> 1. Replace cylinder.

NOTE: If carburetor, fuel line and converter are frosted, close fuel shut-off valve and allow excess fuel to dissipate. Then slowly open fuel shut-off valve 1/4 of fully open. Start engine and run at idle speed until the engine has warmed up. Open valve completely before putting machine to work.

Section 41

HYDRAULIC SYSTEM

TABLE OF CONTENTS

SPECIFICATIONS	3
U.S. AND METRIC TORQUE SPECIFICATIONS	5
HYDRAULIC SYSTEM	6
General	6
Basic Hydraulics Diagram	7
Tilt and Auxiliary Hydraulics Diagram	8
3 Spool Valve	9
Lift Control Valve	11
HYDRAULIC RESERVOIR AND FILTER SERVICE	12
Checking Oil Level	12
Oil Drain and Refill	12
Filter	12
RELIEF VALVE PRESSURE CHECKS AND ADJUSTMENTS	14
3 Spool Main Relief Valve	14
System Relief Valve	14
Variable Speed Relief Valve	14
TROUBLE SHOOTING CHART	16
TESTING THE HYDRAULIC SYSTEM WITH A FLOWMETER	19-22
SERVICING THE 3 SPOOL VALVE	22-24
SERVICING THE LIFT AND TILT CONTROL VALVES	25-28
SERVICING THE VARIABLE SPEED CONTROL VALVE	28-29
LOCK CHECK VALVE	30
Disassembly	30
Assembly	31
HYDRAULIC PUMP	32
Disassembly	32
Assembly	34
CYLINDERS	36
Specifications	36
GROUP 1 CYLINDERS	37
Disassembly	37
Assembly	39
GROUP 2 CYLINDERS	39
Disassembly	39
Assembly	41
7" SHEAR CYLINDER	42
8" SHEAR CYLINDER	44
GRAPPLE CYLINDER	46

SPECIFICATIONS

Hydraulic Pump

Description Spur gear, positive displacement,
driven by gear box output shaft

Output

Model 1530
and 1537 18 gpm @ 1975 psi @ full throttle (2400 rpm)
68 l/mn @ 139 kg/cm² @ full throttle (2400 tr/mn)
Model 1526 17 gpm @ 1975 psi @ full throttle (2300 rpm)
64 l/mn @ 139 kg/cm² @ full throttle (2300 tr/mn)

System relief valve setting 1975 ± 25 psi @ full throttle
139 ± 1,7 kg/cm² @ full throttle

3 Spool Valve

Description Open center type with four parallel
circuits, two work ports per spool

Relief valve setting 1950 ± 25 psi @ full throttle
137 ± 1,7 kg/cm² @ full throttle

Spool travel

Neutral to pressure 1/4" in, 1/4" out
Spool moves INTO valve body Pressurizes port A (nearest spool eye)
Spool moves OUT of valve body Pressurizes port B (nearest spool cap)

Weight 32 pounds (15 kg)

Lift control valve

Description Open center type with four parallel
circuits and two work ports. Detent in
float position.

Spool travel

Neutral to pressure 1/4" in, 1/4" out
Neutral to float 1/2"
Spool moves INTO valve body pressurizes port A (nearest spool eye)
Spool moves OUT of valve body pressurizes port B (nearest spool cap)

Weight 17 pounds (7,7 kg)

Tilt control valve

Description Open center type with four parallel
circuits and two work ports

Spool travel

Neutral to pressure 1/4" in, 1/4" out
Spool moves INTO valve body Pressurizes port A (nearest spool eye)
Spool moves OUT of valve body Pressurizes port B (nearest spool cap)

Weight 15 pounds (6,8 kg)

Hydraulic lines Steel tubing with brazed or flared fittings
and wire braid, high pressure hose with
crimped, full flow fittings

Filter 33 micron throw away element

Reservoir capacity 14 gallons (53 liters)

System capacity.....19 gallons (72 liters)
 Hydraulic oilCase TCH Fluid (see lubricant chart in
 section 13 for alternate oil
 Oil drain interval every 1000 hours



Springs	Free Length	Compressed Length
System and 3 spool relief valves	1.281" ± .005" 32,5 ± ,13 mm	1-3/32" @ 300 lbs. 27,8 mm @ 136,1 kg
Variable speed control relief valve	1-1/32" 26,2 mm	31/32" @ 100 ± 10 lbs. 24,6 mm @ 45,4 ± 4,5 kg
Hydraulic oil filter bypass valve	1.500" ± .015" 38,1 ± ,4 mm	.875" @ 3.8 lbs. 22,2 mm @ 2,1 kg

Cylinders See page 36.
 Check valve (return line) setting Full flow, 14 psi



U.S. AND METRIC TORQUE SPECIFICATIONS

Torque values for all situations unless special torque is specified.

Grade 5 Bolts, Nuts, Studs (Dry)

Thread Size	Torque			Thread Size	Torque	
	ft. lbs.	m-kg			ft. lbs.	m-kg
1/4" - 20 NC	5-10	0,7-1,4		3/4" - 10 NC	235-285	32-39
1/4" - 28 NF	10-15	1,4-2,1		3/4" - 16 NF	270-330	37-46
5/16" - 18 NC	15-20	2,1-2,8		7/8" - 9 NC	360-440	50-61
5/16" - 24 NF	15-20	2,1-2,8		7/8" - 14 NF	395-490	55-68
3/8" - 16 NC	25-35	3,5-4,8		1" - 8 NC	520-640	72-88
3/8" - 24 NF	30-40	4,1-5,5		1" - 12 NF	575-705	79-97
7/16" - 14 NC	45-55	6,2-7,6		1-1/8" - 7 NC	720-820	99-113
7/16" - 20 NF	50-60	6,9-8,3		1-1/8" - 12 NF	790-970	109-134
1/2" - 13 NC	65-85	9,0-12,0		1-1/4" - 7 NC	1010-1240	139-171
1/2" - 20 NF	80-100	11-14		1-1/4" - 12 NF	1115-1365	154-188
9/16" - 12 NC	100-120	14-17		1-3/8" - 6 NC	1315-1610	181-222
9/16" - 18 NF	110-130	15-18		1-3/8" - 12 NF	1510-1850	208-255
5/8" - 11 NC	135-165	19-23		1-1/2" - 6 NC	1745-2135	241-295
5/8" - 18 NF	160-200	22-28		1-1/2" - 12 NF	1880-2420	259-334

Grade 8 Bolts, Nuts, Studs (Dry)

Thread Size	Torque			Thread Size	Torque	
	ft. lbs.	m-kg			ft. lbs.	m-kg
1/4" - 20 NC	10-15	1,4-2,1		3/4" - 10 NC	340-420	47-58
1/4" - 28 NF	15-20	2,1-2,8		3/4" - 16 NF	380-460	52-63
5/16" - 18 NC	20-30	2,8-4,1		7/8" - 9 NC	540-660	75-91
5/16" - 24 NF	25-30	3,5-4,1		7/8" - 14 NF	595-725	82-100
3/8" - 16 NC	40-50	5,5-6,9		1" - 8 NC	810-990	112-137
3/8" - 24 NF	45-55	6,2-7,6		1" - 12 NF	900-1100	124-152
7/16" - 14 NC	60-80	8,3-11,0		1-1/8" - 7 NC	1150-1400	159-193
7/16" - 20 NF	70-90	9,7-12,0		1-1/8" - 12 NF	1295-1585	179-219
1/2" - 13 NC	100-120	14-17		1-1/4" - 7 NC	1640-2000	226-276
1/2" - 20 NF	110-130	15-18		1-1/4" - 12 NF	1800-2200	248-304
9/16" - 12 NC	135-165	19-23		1-3/8" - 6 NC	2140-2620	295-362
9/16" - 18 NF	155-190	21-26		1-3/8" - 12 NF	2450-3000	338-414
5/8" - 11 NC	200-240	28-33		1-1/2" - 6 NC	2845-3475	393-480
5/8" - 18 NF	215-265	30-37		1-1/2" - 12 NF	3200-3900	442-538

Hydraulic Fittings (Steel)

Dash Size	Tube O.D.	Thread Size	37° Flare Female Swivel Torque		Straight Thread O-Ring Torque	
			ft. lbs.	m-kg	ft. lbs.	m-kg
4	1/4"	7/16" - 20	6-12	0,8-1,7	12-19	1,7-2,6
5	5/16"	1/2" - 20	8-16	1,1-2,2	16-25	2,2-3,5
6	3/8"	9/16" - 18	10-25	1,4-3,5	25-40	3,5-5,5
8	1/2"	3/4" - 16	15-42	2,1-5,8	42-67	5,8-9,2
10	5/8"	7/8" - 14	25-58	3,5-8,0	58-92	8,0-12,7
12	3/4"	1-1/16" - 12	40-80	5,5-11,0	80-128	11-18
14	7/8"	1-3/16" - 12	60-100	8,3-14,0	100-160	14-22
16	1"	1-5/16" - 12	75-117	10-16	117-187	16-26
20	1-1/4"	1-5/8" - 12	125-165	17-23	165-264	23-36
24	1-1/2"	1-7/8" - 12	210-250	29-35	250-400	35-55

700926

HYDRAULIC SYSTEM

General

Oil is drawn from the reservoir by the pump and directed to the tilt and auxiliary hydraulics control valve. With the spools of the 3 spool valve in neutral oil then flows to lift control valve, variable speed control valve and oil manifold. When the oil reaches the oil manifold part of the oil is diverted to the clutches for lubrication and the remainder thru the check valve to the suction side of the pump.

The check valve assures an adequate oil supply for clutch lubrication by creating a back pressure of 10-14 psi. The oil in excess of that required for clutch lubrication flows through the check valve to the suction side of

the pump to maintain oil at the pump at all times.

Two relief valves are required to protect the complete system. The main relief valve (set at 1950 ± 25 psi) in the 3 spool valve protects only those circuits connected to the work ports of that valve. The relief valve identified as the system relief valve protects the remainder of the system. The system relief valve is required because as oil pressure builds in the open center passage in the 3 spool valve an equal pressure will be created in the return passage from the main relief valve preventing the relief valve from opening, see Figure 1. When system pressure reaches 1975 ± 25 psi the system relief valve opens, diverting the oil to the suction side of the pump.

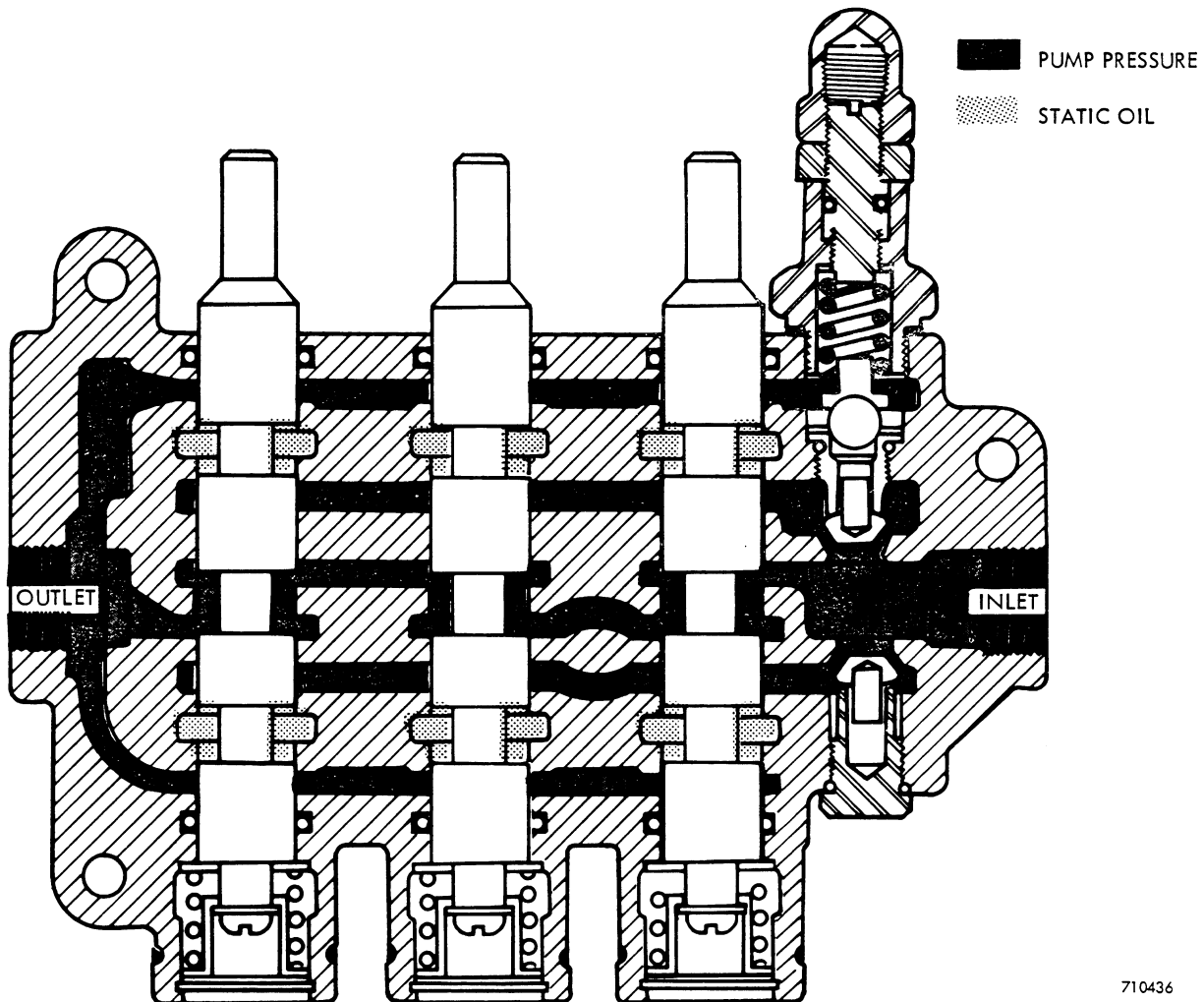
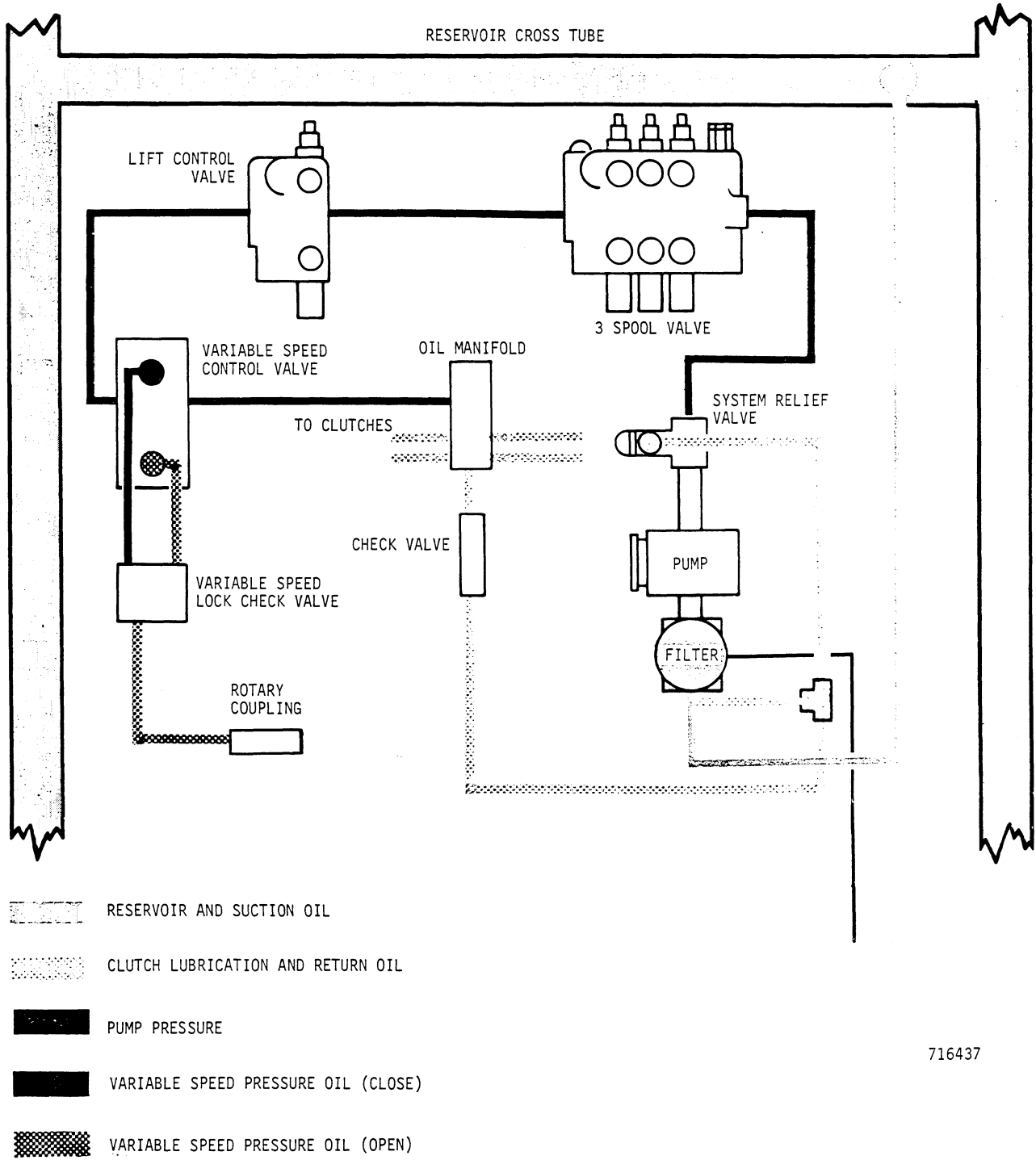

Figure 1 - Relief Valve Locked by Back Pressure



716437

Figure 2 - Hydraulic Diagram, Oil Flow From Pump to Control Valves and Reservoir

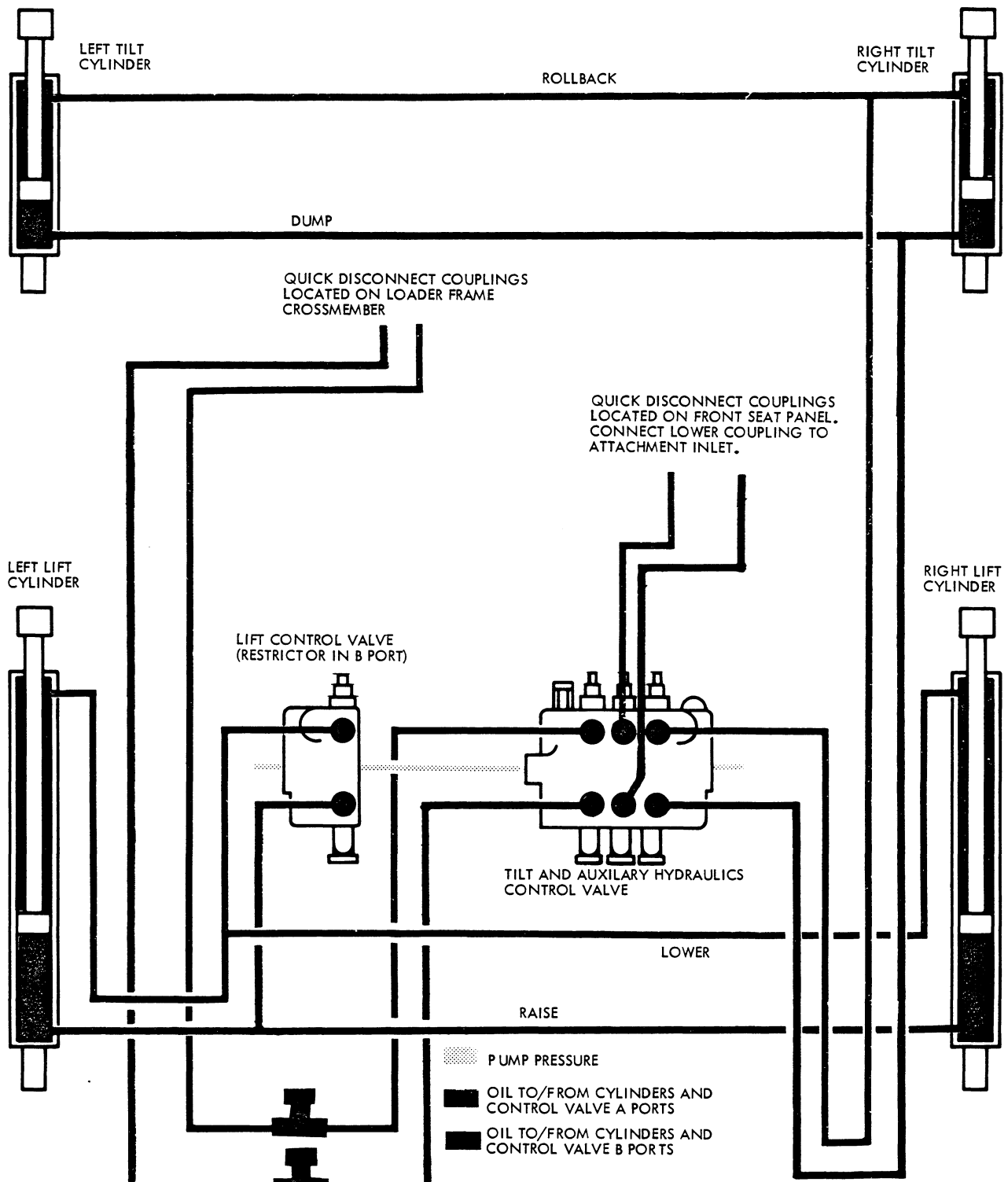

Figure 3 - Hydraulic Diagram of Loader and Auxiliary Hydraulics

3 Spool Valve

Description

The valve is an open center valve with parallel circuits (passages). The passages are illustrated in Figure 4.

The open center passage 1, runs through the center of the valve from the inlet to the outlet. The passage is charged with oil from the pump.

Passages 2 and 3 on both sides of the open center passage direct oil to the work ports via the check valves at the inlet.

The remaining passages, 4 and 5, return oil from the cylinders to the outlet. The main relief valve is also connected to the upper return passage.

The spools are three position spools and spring centered.

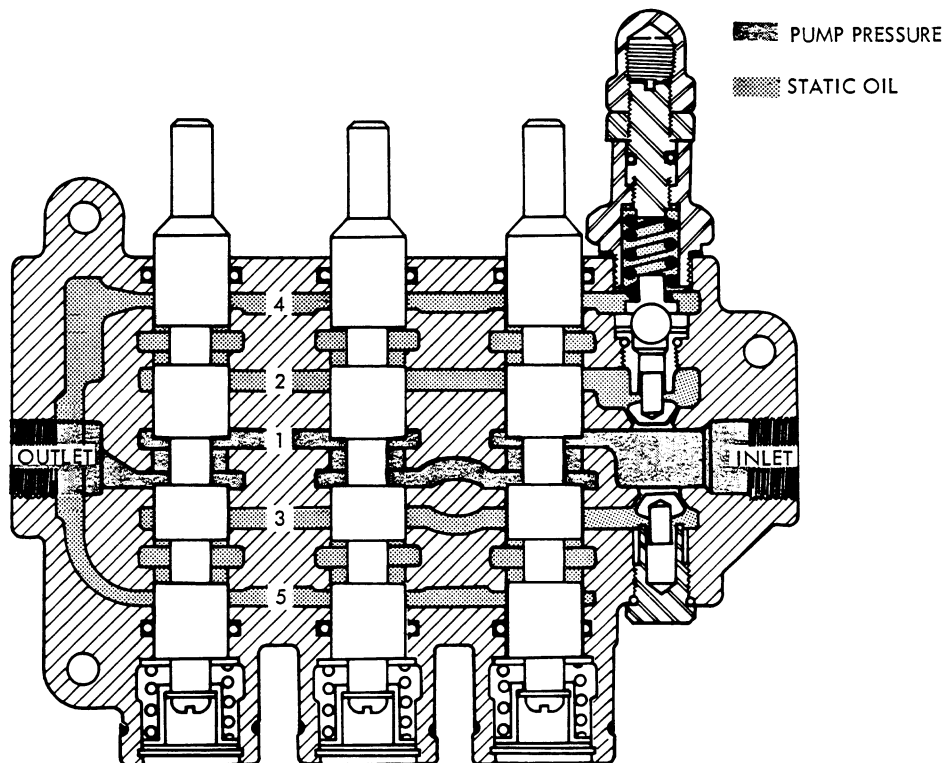

Figure 4 - Oil Flow With Spools In Neutral

Oil Flow

SPOOLS IN NEUTRAL

Refer to Figure 4. With all the spools in neutral, oil flows thru open center to the other control valves which are connected in series with the 3 spool valve. At the same time, the spool lands block the work ports (passage 2 and 3) preventing cylinder movement.

SPOOL ACTUATED

Refer to Figure 5. The spools move into

or out of the valve approximately 1/4" in each direction. Movement into a power position has three effects:

- a. Open center passage 1 is blocked.
- b. The spool lands open a work port to a cylinder. With the open center passage blocked, oil is diverted via the check valves to parallel passages 2 and 3 and flows to the cylinder, causing the cylinder piston to move and perform useful work.
- c. At the same time, the opposite work



Suggest:

If the above button click is invalid.

Please download this document

first, and then click the above link

to download the complete manual.

Thank you so much for reading

port and return passage 5 are connected and oil displaced by the cylinder piston flows from the outlet to the series connected valves and to the reservoir.

The check valves in the inlet prevent the possibility of reverse oil flow.

If more than one spool is actuated, the cylinder with the least resistance will move first.

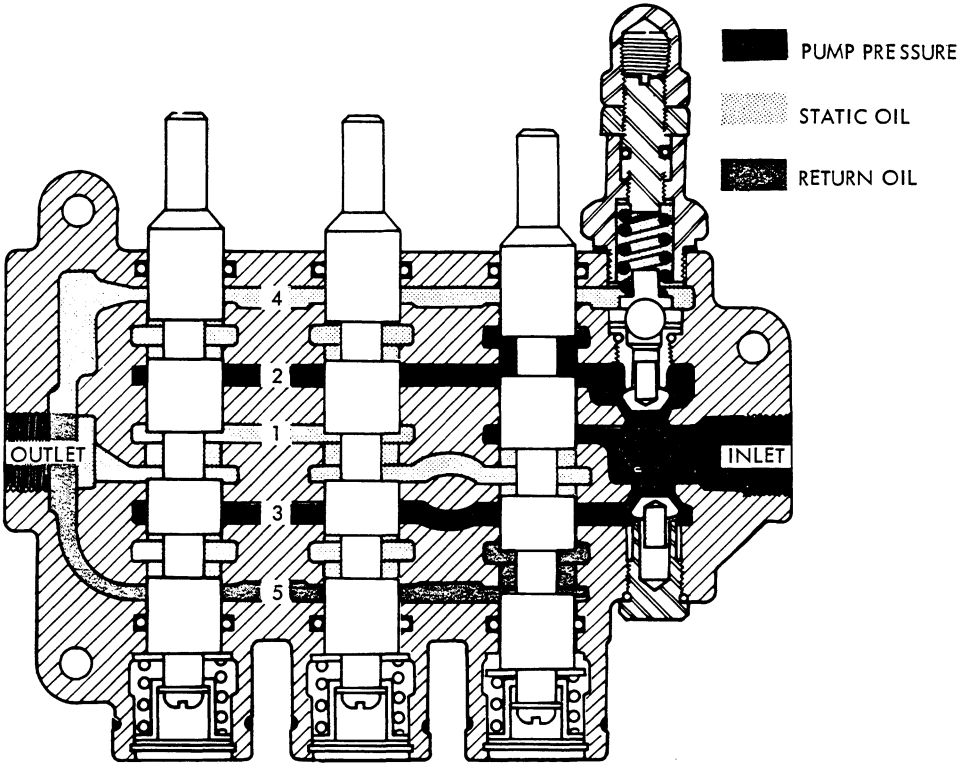

Figure 5 - Oil Flow With Spool Actuated

<https://www.ebooklibonline.com>

Hello dear friend!

Thank you very much for reading.

Enter the link into your browser.

The full manual is available for immediate download.

<https://www.ebooklibonline.com>