

---

## TO READER

This manual has been printed for a kilful engineer to supply necessary technical information to carry out service operations on this machine.

### CNH France S.A.

Rue des Meuniers - 60330  
Le Plessis Belleville - France

Read carefully this manual to collect correct information relevant to repair procedures.

For any question or remark, or in case of any error relevant the contents of this manual, please contact:

---

## REFERENCE

Beyond this Service Manual, also refer to documents hereunder listed:

- Operator's Manual
- Parts Catalogue

---

## COMPLETE HANDBOOK FOR INSTRUCTIONS AND REPAIRS

The complete Service Manual consists of two volumes:

- 580 Super R - 590 Super R - 695 Super R Service Manual "LOADER BACKHOE"
- 580 Super R - 590 Super R - 695 Super R Service Manual "Engine"

The Service Manuals for "Loader backhoe" and "Engine" contain the necessary technical information to carry out service and repair on machine and on engine, necessary tools to carry out those operations and information on service standard, on procedures for connection, disconnection, disassembly and assembly of parts.

The complete Service Manual which covers the loader backhoe models 580 Super R - 590 Super R - 695 Super R consists of the following volumes, which can be identified through their print no. as stated below:

VOLUME	MACHINE TYPE	PRINT NUMBER
Service Manual - "Loader backhoe"	580 Super R - 590 Super R - 695 Super R	87570830A
Service Manual - "Engine"	580 Super R - 590 Super R - 695 Super R	9-88900

---

# INDEX

## SECTION 00 - SAFETY PRECAUTIONS

## SECTION 01 - MAINTENANCE

## SECTION 02 - TECHNICAL SPECIFICATIONS

1. LOADER BACKHOE MODELS .....	3
2. IDENTIFICATION OF MAIN COMPONENTS.....	4
3. TECHNICAL SPECIFICATIONS.....	5
4. LOADER ATTACHMENT DIMENSIONS AND PERFORMANCE .....	9
5. BACKHOE ATTACHMENT DIMENSIONS AND PERFORMANCE .....	12
6. LIFTING CAPACITIES.....	15
7. LOADER BUCKET WITH FORKS DIMENSIONS AND PERFORMANCE.....	18
8. FLUID AND LUBRICANT CAPACITIES AND SPECIFICATIONS.....	19

## SECTION 17 - TORQUE CONVERTERS

1. POWERSHUTTLE TORQUE CONVERTER .....	3
1.1 DESCRIPTION AND OPERATION.....	3
1.2 TECHNICAL SPECIFICATIONS.....	4
1.3 OVERHAUL .....	4
1.4 INSPECTION.....	4
1.5 DISASSEMBLY AND ASSEMBLY.....	5
1.6 STALL TEST.....	5
1.7 FAULT FINDING.....	6
2. POWERSHIFT TORQUE CONVERTER .....	7
2.1 DESCRIPTION AND OPERATION.....	7
2.2 TECHNICAL SPECIFICATIONS.....	8
2.3 OVERHAUL .....	8
2.4 INSPECTION.....	9
2.5 DISASSEMBLY AND ASSEMBLY.....	9
2.6 STALL TEST.....	11
2.7 FAULT FINDING.....	12

## SECTION 21 - TRANSMISSION

1. POWERSHUTTLE TRANSMISSION "TURNER MODEL COM-T4-2025" .....	3
1.1 TECHNICAL SPECIFICATIONS.....	3
1.2 TIGHTENING TORQUES .....	5
1.3 TRANSMISSION CONTROLS.....	6
1.4 LUBRICATION.....	11
1.5 TRANSMISSION OIL FLOW AND SUPPLY.....	12
1.6 TRANSMISSION HYDRAULIC VALVES AND PRESSURE TEST POINTS.....	18
1.7 TRANSMISSION POWER FLOW.....	19
1.8 TRANSMISSION 2WD COMPONENTS.....	23
1.9 TRANSMISSION 4WD COMPONENTS.....	26
1.10 TRANSMISSION REMOVAL .....	31
1.11 DISASSEMBLY AND ASSEMBLY.....	32
1.12 FAULT FINDING.....	90

1.13 SPECIAL TOOLS.....	93
2. POWERSHIFT TRANSMISSION “DANA T16000” .....	94
2.1 TECHNICAL SPECIFICATIONS.....	94
2.2 TRANSMISSION CONTROLS.....	95
2.3 LUBRICATION.....	105
2.4 PRESSURE SPECIFICATIONS AND CHECK POINTS.....	106
2.5 TRANSMISSION COOLER.....	108
2.6 TRANSMISSION HYDRAULIC DIAGRAM .....	109
2.7 OPERATION .....	110
2.8 POWER FLOWS.....	117
2.9 134GEAR AND CLUTCH LAY OUT .....	132
2.10 TRANSMISSION / ENGINE REMOVAL FROM LOADER.....	133
2.11 TRANSMISSION COMPONENTS.....	137
2.12 DISASSEMBLY AND ASSEMBLY.....	155
2.13 SPECIAL TOOLS.....	264
2.14 FAULT FINDING.....	265
2.15 FAULT FINDING.....	267

## SECTION 25 - FRONT AXLES

1. FRONT AXLE 2WD “CARRARO” .....	3
1.1 TECHNICAL SPECIFICATIONS.....	3
1.2 DISASSEMBLY AND ASSEMBLY.....	5
1.3 FAULT FINDING .....	23
2. FRONT AXLE 4WD “CARRARO” .....	25
2.1 TECHNICAL SPECIFICATIONS.....	25
2.2 DISASSEMBLY AND ASSEMBLY.....	31
2.3 FAULT FINDING .....	77
3. FRONT AXLE 4WS “CARRARO” .....	80
3.1 TECHNICAL SPECIFICATIONS.....	80
3.2 DISASSEMBLY AND ASSEMBLY.....	84
3.3 FAULT FINDING .....	137
4. SPECIAL TOOLS.....	140

## SECTION 27 - REAR AXLE

1. REAR AXLE 2WS .....	3
1.1 DESCRIPTION AND OPERATION.....	3
1.2 TECHNICAL SPECIFICATIONS.....	6
1.3 DISASSEMBLY AND ASSEMBLY.....	8
1.4 FAULT FINDING .....	27
2. REAR AXLE 4WS “CARRARO” .....	28
2.1 TECHNICAL SPECIFICATIONS.....	28
2.2 DISASSEMBLY AND ASSEMBLY.....	32
2.3 FAULT FINDING .....	81
3. SPECIAL TOOLS.....	84

## SECTION 33 - BRAKES SYSTEM

1. TECHNICAL SPECIFICATIONS.....	3
2. HAND BRAKE.....	6
2.1 HAND BRAKE ADJUSTMENT.....	7

**<https://www.ebooklibonline.com>**

Hello dear friend!

Thank you very much for reading.

Enter the link into your browser.

The full manual is available for immediate download.

**<https://www.ebooklibonline.com>**

---

3. BRAKE MASTER CYLINDERS .....	8
3.1 BRAKE TANK .....	13
3.2 BRAKE BLEEDING PROCEDURE.....	13

## **SECTION 35 - HYDRAULIC SYSTEM**

1. HYDRAULIC DIAGRAMS .....	3
1.1 HYDRAULIC DIAGRAM - 2WS SIDESHIFT MECHANICAL MODELS.....	3
1.2 HYDRAULIC DIAGRAM - 2WS CENTRE PIVOT PILOT MODELS .....	5
1.3 HYDRAULIC DIAGRAM - 2WS SIDESHIFT PILOT MODELS.....	8
1.4 HYDRAULIC DIAGRAM - 4WS CENTRE PIVOT MECHANICAL MODELS .....	11
1.5 HYDRAULIC DIAGRAM - 4WS SIDESHIFT MECHANICAL MODELS.....	13
1.6 HYDRAULIC DIAGRAM - 4WS CENTRE PIVOT PILOT MODELS .....	15
1.7 HYDRAULIC DIAGRAM - 4WS SIDESHIFT PILOT MODEL .....	18
2. HYDRAULIC PUMP .....	21
2.1 DESCRIPTION AND OPERATION.....	21
2.2 TECHNICAL SPECIFICATIONS.....	22
2.3 LOAD SENSING VALVE .....	24
2.4 REMOVAL .....	26
2.5 COMPONENTS .....	27
2.6 DISASSEMBLY AND ASSEMBLY.....	28
3. CONTROL VALVES .....	32
3.1 CONTROL VALVES "REXROTH" (MECHANICAL MODELS) .....	32
3.2 CONTROL VALVES "REXROTH" (PILOT MODELS) .....	48
4. HYDRAULIC SWING SYSTEM .....	71
4.1 DESCRIPTION AND OPERATION.....	71
4.2 HYDRAULIC OIL FLOW .....	72
4.3 PRECISION SWING CONTROL .....	74
5. HYDRAULIC CYLINDERS.....	77
5.1 LOADER CYLINDER .....	78
5.2 LOADER BUCKET CYLINDER .....	83
5.3 4X1 BUCKET CYLINDER.....	87
5.4 BACKHOE BOOM CYLINDER .....	90
5.5 BACKHOE CROWD CYLINDER .....	94
5.6 BACKHOE BUCKET CYLINDER.....	98
5.7 SHORT AND LONG TELESCOPIC CYLINDER.....	102
5.8 STABILIZER CYLINDER (CENTRE PIVOT - 4WS) .....	106
5.9 STABILIZER CYLINDER (SIDESHIFT).....	110
5.10 SWING CYLINDER.....	114
5.11 SIDESHIFT CARRIAGE CYLINDER (SIDESHIFT).....	118
5.12 SPECIAL TOOLS.....	120
6. PILOT HYDRAULIC CONTROL LEVERS .....	121
6.1 TECHNICAL SPECIFICATIONS.....	121
6.2 DESCRIPTION AND OPERATION.....	122
6.3 DISASSEMBLY AND ASSEMBLY.....	125
6.4 PILOT HYDRAULIC CONTROL VALVE.....	128
7. FAULT FINDING AND FLOW TESTING .....	131
7.1 PRELIMINARY CHECKS.....	131
7.2 FAULT FINDING.....	132
7.3 PRESSURE TESTING.....	136

---

---

**SECTION 39 - CHASSIS**

1. DESCRIPTION AND OPERATION .....	3
2. REMOVAL AND INSTALLATION COMPONENTS.....	5
2.1 COMPONENTS WITHIN THE CHASSIS.....	5
2.2 COMPONENTS BELOW THE CHASSIS .....	6
2.3 COMPONENTS ATTACHED OUTSIDE THE CHASSIS .....	8
2.4 COMPONENTS ATTACHED ABOVE THE CHASSIS.....	9
2.5 TIGHTENING TORQUES .....	11

**SECTION 41 - STEERING SYSTEM**

1. STEERING SYSTEM 2WS .....	4
2. STEERING SYSTEM 4WS .....	7
3. STEERING MOTOR .....	12
3.1 TECHNICAL SPECIFICATIONS.....	13
3.2 COMPONENTS .....	15
3.3 DISASSEMBLY AND ASSEMBLY .....	16
3.4 SPECIAL TOOLS.....	33
3.5 FAULT FINDING .....	33

**SECTION 50 - CAB HEATING AND AIR CONDITIONING**

1. TECHNICAL SPECIFICATIONS.....	3
2. CAB HEATING.....	5
2.1 DESCRIPTION AND OPERATION.....	5
3. AIR CONDITIONING.....	12
3.1 PRINCIPALS OF AIR CONDITIONING .....	12
3.2 SAFETY PRECAUTIONS .....	16
3.3 DESCRIPTION AND OPERATION.....	17
3.4 FAULT FINDING AND TESTING.....	25
3.5 FLUSHING THE SYSTEM.....	43
3.6 EVACUATING THE SYSTEM.....	45
3.7 CHARGING THE SYSTEM.....	46
3.8 COMPONENTS OVERHAUL.....	47
3.9 COMPRESSOR .....	51
3.10 SPECIAL TOOLS.....	65

**SECTION 55 - ELECTRICAL SYSTEM**

1. GENERALITIES .....	3
1.1 TEMPORARY WIRING HARNESS REPAIR .....	3
1.2 FAULT FINDING .....	4
2. ELECTRICAL DIAGRAMS.....	5
2.1 ELECTRICAL DIAGRAMS - POWERSHUTTLE CAB .....	5
2.2 ELECTRICAL DIAGRAMS - POWERSHIFT CAB .....	25
2.3 ELECTRICAL DIAGRAMS - 4WS.....	45
2.4 ELECTRICAL DIAGRAMS - ROPS .....	65
3. CONTROLS AND INSTRUMENTS.....	81
3.1 FRONT INSTRUMENT PANEL (580 Super R - 590 Super R) .....	81
3.2 SIDE INSTRUMENT PANEL (695 Super R).....	83
3.3 SIDE PANEL.....	85
3.4 DIAGNOSTIC SIGNALING .....	88

---

3.5 CALIBRATION OF SPEEDOMETER .....	90
3.6 IMMOBILISER CIRCUIT.....	91
4. STARTING SYSTEM .....	92
4.1 DESCRIPTION AND OPERATION.....	92
4.2 FAULT FINDING.....	93
4.3 STARTER MOTOR.....	96
5. ALTERNATOR.....	102
5.1 TECHNICAL SPECIFICATIONS.....	102
5.2 DESCRIPTION AND OPERATION.....	102
5.3 COMPONENTS .....	104
5.4 REMOVAL .....	105
5.5 PRELIMINARY CHECK AND TESTS.....	106
5.6 FAULT FINDING.....	115
6. BATTERY .....	116
6.1 TECHNICAL SPECIFICATIONS.....	116
6.2 DESCRIPTION AND OPERATION.....	116
6.3 REMOVAL AND INSTALLATION .....	117
6.4 MAINTENANCE.....	119
6.5 TESTS .....	121
6.6 CONNECTING A BOOSTER BATTERY .....	123
6.7 BATTERY MASTER SWITCH .....	123
7. COMPONENT TESTING .....	124
7.1 GENERAL INTRODUCTION .....	124
7.2 COMPONENT TESTING .....	125
7.3 GROUND POINTS.....	125

## **SECTION 82 - LOADER**

1. LOADER ATTACHMENT CONTROLS.....	3
2. LOADER BUCKET SELF LEVELING .....	6
3. LOADER ATTACHMENT SAFETY STRUT.....	7
4. LOADER BUCKET REMOVAL .....	9
5. LOADER ARM REMOVAL.....	11

## **SECTION 84 - BACKHOE**

1. DESCRIPTION AND OPERATION.....	3
2. BACKHOE ATTACHMENT MECHANICAL CONTROL VERSION .....	6
3. BACKHOE ATTACHMENT PILOT CONTROL VERSION.....	13
4. REMOVAL AND INSTALLATION .....	15
5. TELESCOPIC DIPPER REVISION.....	25

**SECTIONS INDEX**

Where disassembly of a specific component is required refer to the relevant repair manual section.

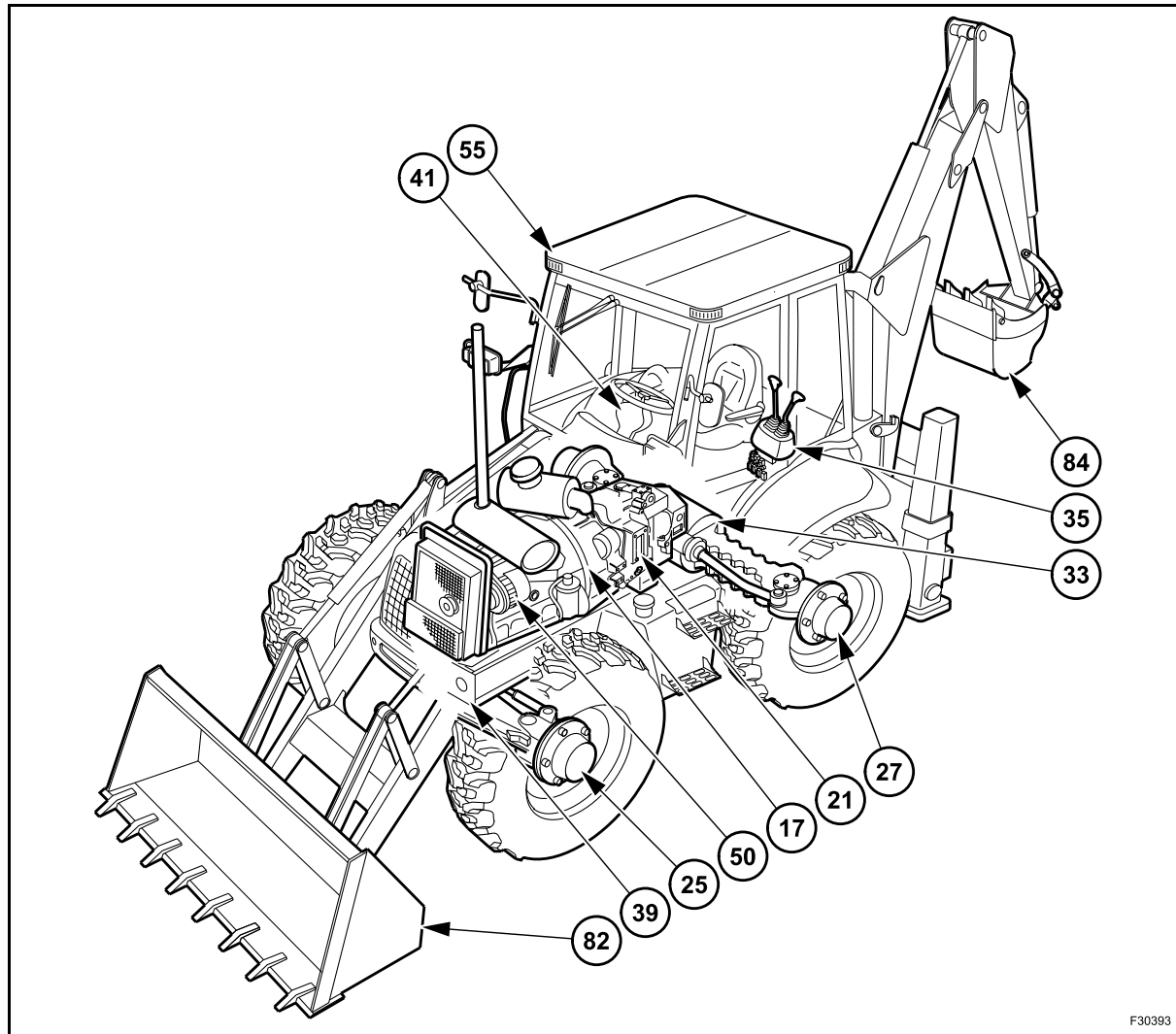

F30393

**SECTION 17: TORQUE CONVERTER**

**SECTION 21: TRANSMISSION**

**SECTION 25: FRONT AXLE**

**SECTION 27: REAR AXLE**

**SECTION 33: BRAKE SYSTEM**

**SECTION 35: HYDRAULIC SYSTEM**

**SECTION 39: CHASSIS**

**SECTION 41: STEERING SYSTEM**

**SECTION 50: CAB HEATING AND AIR CONDITIONING**

**SECTION 55: ELECTRICAL SYSTEM**

**SECTION 82: LOADER**

**SECTION 84: BACKHOE**

**580 Super R**  
**590 Super R**  
**695 Super R**



**SECTION 00 - SAFETY PRECAUTIONS**

This warning symbol points out important messages involving personal safety.

Carefully read the safety rules contained herein and follow advised precautions to avoid potential hazards and safeguard your safety and personal integrity.

In this manual you will find this symbol together with the following key-words:

**WARNING** - it gives warning about improper repair operations and deriving potential consequences affecting the service technician's personal safety.

**DANGER** - it gives specific warning about potential dangers for personal safety of the operator or other persons directly or indirectly involved.



### TO PREVENT ACCIDENTS

Most accidents and personal injuries that occur in industry, on the farm, at home or on the road, are caused by the failure of some individual to follow simple and fundamental safety rules or precautions.

For this reason, MOST ACCIDENTS CAN BE PREVENTED by recognizing the real cause and taking the necessary precautions, before the accident occurs.

Regardless of the care used in design and construction of any type of equipment, there may be conditions that cannot be completely safeguarded against, without interfering with reasonable accessibility and efficient operation.

A careful operator or technician is the best precaution against accidents. The complete observance of one simple rule would prevent many thousands of serious injuries each year.

This rule is: Never attempt to clean, lubricate or adjust a machine while it is in motion.

**SAFETY RULES**

- Carefully follow specified repair and maintenance procedures.
  - Do not wear rings, wristwatches, jewels, unbuttoned or flapping clothing such as ties, torn clothes, scarves, open jackets or shirts with open zips which could get hold into moving parts. We advise to use approved safety clothing such as anti-slipping footwear, gloves, safety goggles, helmets, etc.
  - Never carry out any repair on the machine if someone is sitting on the operator's seat, except if they are certified operators to assist in the operation to be carried out.
  - Never operate the machine or use attachments from a place other than sitting at the operator's seat.
  - Never carry out any operation on the machine when the engine is running, except when specifically indicated.
  - Stop the engine and ensure that all pressure is relieved from hydraulic circuits before removing caps, covers, valves, etc.
  - All repair and maintenance operations should be carried out with the greatest care and attention.
  - Service stairs and platforms used in a workshop or in the field should be built in compliance with the safety rules in force.
  - Disconnect the batteries and label all controls to warn that the Machine is being serviced. Block the machine and all equipment which should be raised.
  - Never check or fill fuel tanks and accumulator batteries, nor use starting liquid if you are smoking or near open flames as such fluids are flammable.
  - Brakes are inoperative when they are manually released for maintenance purposes. In such cases, the machine should be kept constantly under control using blocks or similar devices.
  - The fuel filling gun should remain always in contact with the filler neck. Maintain this contact until the fuel stops flowing into the tank to avoid possible sparks due to static electricity buildup.
  - Use exclusively specified towing points for towing the machine. Connect parts carefully. Ensure that foreseen pins and/or locks are steadily fixed before applying traction. Do not stop near towing bars, cables or chains working under load.
  - To transfer a failed machine, use a trailer or a low loading platform trolley if available.
  - To load and unload the machine from the transportation mean, select a flat area providing a firm support to the trailer or truck wheels. Firmly tie the machine to the truck or trailer platform and block wheels as required by the forwarder.
  - For electrical heaters, battery-chargers and similar equipment use exclusive auxiliary power supplies with a efficient ground to avoid electrical shock hazard.
  - Always use lifting equipment and similar of appropriate capacity to lift or move heavy components.
  - Pay special attention to bystanders.
  - Never pour gasoline or diesel oil into open, wide and low containers.
  - Never use gasoline, diesel oil or other flammable liquids as cleaning agents. Use non-flammable non-toxic proprietary solvents.
  - Wear protection goggles with side guards when cleaning parts using compressed air.
  - Do not exceed a pressure of 2.1 bar, in accordance with local regulations.
  - Do not run the engine in a closed building without proper ventilation.
  - Do not smoke, use open flames, cause sparks in the nearby area when filling fuel or handling highly flammable liquids.
  - Do not use flames as light sources when working on a machine or checking for leaks.
  - Move with caution when working under a Machine, and also on or near a Machine. Wear proper safety accessories: helmets, goggles and special footwear.
  - During checks which should be carried out with the engine running, ask an assistant to sit at the operator's seat and keep the service technician under visual control at any moment. In case of operations outside the workshop, drive the machine to a flat area and block it. if working on an incline cannot be avoided, first block the Machine carefully. Move it to a flat area as soon as possible with a certain extent of safety.
  - Ruined or plied cables and chains are unreliable. Do not use them for lifting or trailing. Always handle them wearing gloves of proper thickness.
  - Chains should always be safely fastened. Ensure that fastening device is strong enough to hold the load foreseen. No persons should stop near the fastening point, trailing chains or cables.
  - The working area should be always kept CLEAN and DRY. Immediately clean any spillage of water or oil.
  - Do not pile up grease or oil soaked rags, as they constitute a great fire hazard. Always place them into a metal container. Before starting the Machine or its attachments, check, adjust and block the operator's seat. Also ensure that there are no persons within the Machine or attachment operating range.
  - Do not keep in your pockets any object which might fall unobserved into the Machine's inner compartments.
-

- Whenever there is the possibility of being reached by ejected metal parts or similar, use protection eye mask or goggles with side guards, helmets, special footwear and heavy gloves. Wear suitable protection such as tinted eye protection, helmets, special clothing, gloves and footwear whenever it is necessary to carry out welding procedures. All persons standing in the vicinity of the welding process should wear tinted eye protection. NEVER LOOK AT THE WELDING ARC IF YOUR EYES ARE NOT SUITABLY PROTECTED.
- Metal cables with the use get frayed. Always wear adequate protections (heavy gloves, eye protection, etc.).
- Handle all parts with the greatest caution. Keep your hands and fingers far from gaps, moving gears and similar. Always use approved protective equipment, such as eye protection, heavy gloves and protective footwear.

#### START UP

- Never run the engine in confined spaces which are not equipped with adequate ventilation for exhaust gas extraction.
- Never bring your head, body, arms, legs, feet, hands, fingers near fans or rotating belts.

#### ENGINE

- Always loosen the radiator cap very slowly before removing it to allow pressure in the system to dissipate. Coolant should be topped up only when the engine is stopped or idle if hot.
- Do not fill up fuel tank when the engine is running, mainly if it is hot, to avoid ignition of fires in case of fuel spilling.
- Never check or adjust the fan belt tension when the engine is running. Never adjust the fuel injection pump when the machine is moving.
- Never lubricate the machine when the engine is running.

#### ELECTRICAL SYSTEMS

- If it is necessary to use auxiliary batteries, cables must be connected at both sides as follows: (+) to (+) and (-) to (-). Avoid short-circuiting the terminals. GAS RELEASED FROM BATTERIES IS HIGHLY FLAMMABLE. During charging, leave the battery compartment uncovered to improve ventilation. Avoid checking the battery charge by means of "jumpers" made by placing metallic objects across the terminals. Avoid sparks or flames near the battery area. Do not smoke to prevent explosion hazards.
- Prior to any service, check for fuel or coolant leaks. Remove these leaks before going on with the work. Do not charge batteries in confined spaces. Ensure that ventilation is appropriate to prevent acci-

idental explosion hazard due to build-up of gasses relieved during charging.

- Always disconnect the batteries before performing any type of service on the electrical system.

#### HYDRAULIC SYSTEMS

- Some fluid slowly coming out from a very small port can be almost invisible and be strong enough to penetrate the skin. For this reason, NEVER USE YOUR HANDS TO CHECK FOR LEAKS, but use a piece of cardboard or a piece of wood for this purpose. If any fluid is injected into the skin, seek medical aid immediately. Lack of immediate medical attention, serious infections or dermatitis may result.
- Always take system pressure readings using the appropriate gauges.

#### WHEELS AND TYRES

- Check that the tyres are correctly inflated at the pressure specified by the manufacturer. Periodically check possible damages to the rims and tyres.
- Keep off and stay at the tyre side when correcting the inflation pressure.
- Check the pressure only when the machine is unloaded and tyres are cold to avoid wrong readings due to over-pressure. Do not reuse parts of recovered wheels as improper welding, brazing or heating may weaken the wheel and make it fail.
- Never cut, nor weld a rim with the inflated tyre assembled.
- To remove the wheels, block both front and rear Machine wheels. Raise the Machine and install safe and stable supports under the Machine in accordance with regulations in force.
- Deflate the tyre before removing any object caught into the tyre tread.
- Never inflate tyres using flammable gases as they may originate explosions and cause injuries to bystanders.

#### REMOVAL AND INSTALLATION

- Lift and handle all heavy components using lifting equipment of adequate capacity. Ensure that parts are supported by appropriate slings and hooks. Use lifting eyes provided to this purpose. Take care of the persons near the loads to be lifted.
- Handle all parts with great care. Do not place your hands or fingers between two parts. Wear approved protective clothing such as safety goggles, gloves and footwear.
- Do not twist chains or metal cables. Always wear protection gloves to handle cables or chains.

**IMPORTANT ECOLOGICAL CONSIDERATIONS**

The following are recommendations which may be of assistance:

- Become acquainted with and ensure that you understand the relative legislation applicable to your country.
- Where no legislation exists, obtain information from suppliers of oils, fuels, antifreeze, cleaning agents, etc., with regard to their effect on man and nature and how to safely store, use and dispose of these substances.

**Helpful hints**

- Avoid filling tanks using jerry cans or inappropriate pressurized fuel delivery systems which may cause considerable spillage.
  - In general, avoid skin contact with all fuels, oils, acids, solvents, etc.  
Most of them contain substances which can be harmful to your health.
  - Modern oils contain additives. Do not burn contaminated fuels and/or waste oils in ordinary heating systems.
  - Avoid spillage when draining off used engine coolant mixtures, engine, transmission and hydraulic oils, brake fluids, etc.  
Do not mix drained brake fluids or fuels with lubricants. Store them safely until they can be disposed of in a proper way to comply with local legislation and available resources.
  - Modern coolant mixtures, i.e. antifreeze and other additives, should be replaced every two years. They should not be allowed to get into the soil but should be collected and disposed of safely.
  - Do not open the Air-Conditioning system yourself. It may contain gases which should not be released into the atmosphere. Your air conditioning specialist has special equipment for discharging and charging the system.
  - Repair any leaks or defects in the engine cooling or hydraulic system immediately.
  - Do not increase the pressure in a pressurized circuit as this may lead to a catastrophic failure of the system components.
  - Protect hoses during welding as penetrating weld splatter may burn a hole or weaken them, causing the loss of oils, coolant, etc.
-

**580 Super R**  
**590 Super R**  
**695 Super R**

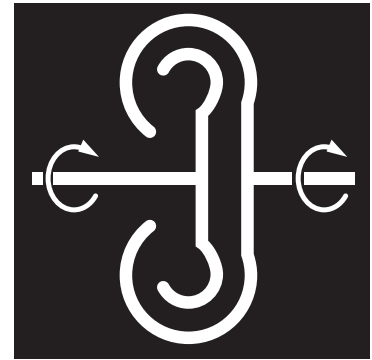

## **SECTION 17 - TORQUE CONVERTERS**

1. POWERSHUTTLE TORQUE CONVERTER .....	3
1.1 DESCRIPTION AND OPERATION.....	3
1.2 TECHNICAL SPECIFICATIONS.....	4
1.3 OVERHAUL .....	4
1.4 INSPECTION.....	4
1.5 DISASSEMBLY AND ASSEMBLY.....	5
1.6 STALL TEST.....	5
1.7 FAULT FINDING.....	6
2. POWERSHIFT TORQUE CONVERTER .....	7
2.1 DESCRIPTION AND OPERATION.....	7
2.2 TECHNICAL SPECIFICATIONS.....	8
2.3 OVERHAUL .....	8
2.4 INSPECTION.....	9
2.5 DISASSEMBLY AND ASSEMBLY.....	9
2.6 STALL TEST.....	11
2.7 FAULT FINDING.....	12

## 1. POWERSHUTTLE TORQUE CONVERTER

### 1.1 DESCRIPTION AND OPERATION

The torque converter is the connection between the engine and the transmission and is hydraulically actuated. The main parts of the torque converter (A) are the impeller (pump), the turbine, the stator and the front and rear covers. The impeller is integral with the rear cover and is driven by the engine fly-wheel by means of a drive plate.

The stator, is splined to a stationary shaft (stator support) through a one-way clutch that permits the stator to rotate only in the same direction as the impeller. All of the converter parts are enclosed in an oil-filled housing. The front and rear cover, being welded together, form the housing.

The turbine (2), splined to the front input shaft, is splined to a stationary shaft (stator support) through a one-way clutch that permits the stator (3) to rotate only in the same direction as the impeller (1). All of the converter parts are enclosed in an oil-filled housing. When the engine is running, the oil in the converter flows from the impeller (1) to the turbine (2) and back to the impeller through the stator (3). This flow produces a maximum torque increase.

When enough oil flow is developed by the impeller, the turbine begins to rotate, driving the front input shaft. The torque multiplication gradually decreases as turbine speed approaches impeller speed, and becomes 1 to 1 when the turbine is being driven at nine tenths impeller speed.

When the turbine (2) is rotating at approximately nine tenths impeller speed, the converter stops multiplying torque because the oil is now acting on the rear face of the stator blades (4). The action of the oil on the rear face of the stator unlocks the one-way clutch (5), permitting the stator to rotate in the same direction as the turbine (2) and impeller (1). Through this action the converter becomes an efficient fluid coupling by transmitting engine torque from the impeller to the turbine. To achieve optimum operation the engine performance, transmission ratios, hydraulic power delivery and converter torque multiplication are all "Matched" to provide the necessary vehicle drive torque when required. When the turbine is rotating less than nine tenths impeller speed (1), the converter is multiplying torque through the action of the stator (3). This action, produced by oil acting on the front face of the stator blades, tends to rotate the stator in the opposite direction of the impeller (1) and turbine (2). However, the one-way clutch prevents this opposite rotation and allows the stator to direct oil back to the impeller, thereby producing torque multiplication. Maximum torque multiplication is achieved when the impeller is driven at stall speed and the turbine is stationary.

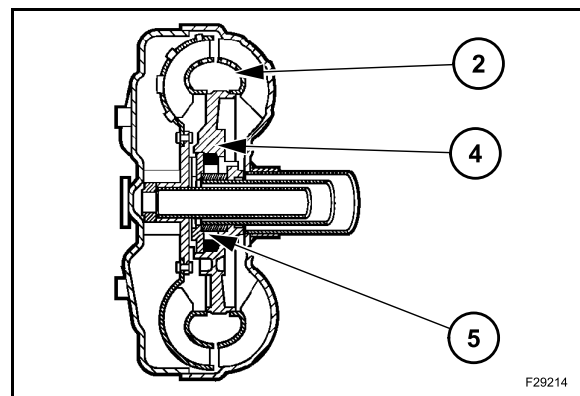
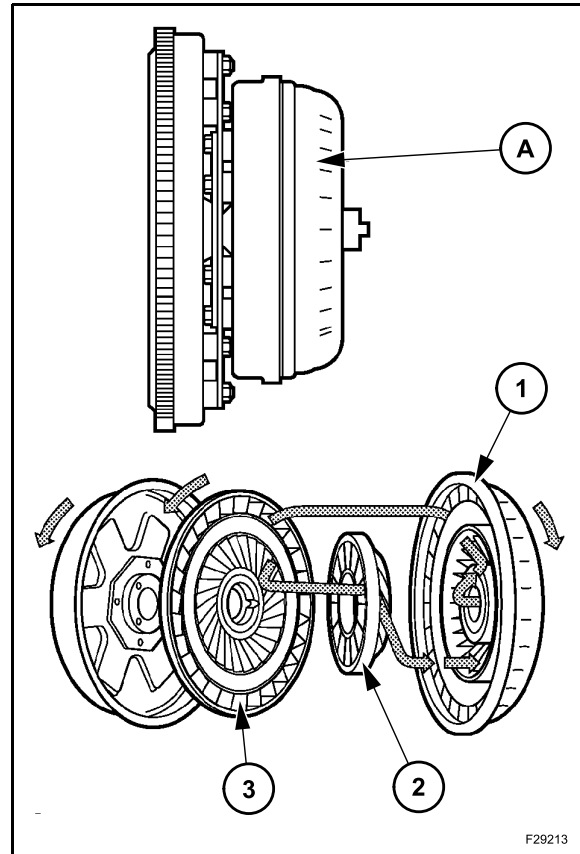

## 1.2 TECHNICAL SPECIFICATIONS

Torque converter ratio.....	2.38:1
Weight.....	17.4 kg
Torque of retaining screws for transmission .....	58 Nm
Torque of retaining screw for flywheel .....	41 Nm
Torque of screw for drive plate to the convertor.....	53 Nm
Torque of screw for drive plate to the flywheel.....	41 Nm

### Hydraulic tests

Tachometer setting .....	2000 revs/min
Test temperature, oil .....	80-85 °C
Cold start valve (For reference only).....	26 bar
System pressure test .....	13.7-15.2 bar
Torque converter.....	7-11 bar

## 1.3 OVERHAUL

The torque converter, is a welded unit and cannot be disassembled. The only maintenance performed on the converter, other than the stall test, is cleaning and visual inspection. A commercial torque converter cleaner may be used to clean the converter. However, if a commercial cleaner is not available, the converter should be cleaned as outlined below.

- Drain as much oil as possible from the hub of the converter by tilting the converter in all directions.
- Fill the converter about half full, through the hub (1), with paraffin base solvent or any cleaning solvent specified for cleaning transmissions.
- Plug the opening in the hub, then circulate the solvent inside the converter by rotating and shaking.
- Drain the solvent from the converter.
- Repeat previous steps, as required, until the solvent that is drained from the converter is clean.

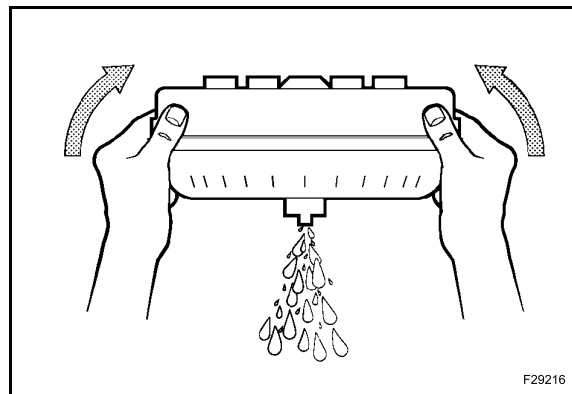
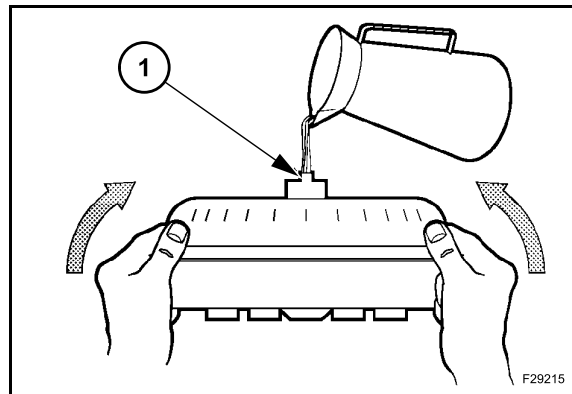

## 1.4 INSPECTION

Inspect the splines on the converter hub for wear or damage and the weld joints for cracks. If the hub is worn or damaged and/or the weld joints cracked, a new converter must be installed. A new drive plate should also be installed if it is warped.

### 1.5 DISASSEMBLY AND ASSEMBLY

- Secure the drive plate (3) to the torque converter (5), with the attaching bolts and flat washers (1).
- Tighten bolts to 53 Nm.
- Prior to fitting the transmission place the torque converter carefully over the transmission shaft and into the transmission housing.
- With the transmission bolted to the engine secure the drive plate to the flywheel (6) accessed through the starter motor aperture, with the attaching bolts and washers (2). Tighten bolts to 41 Nm.

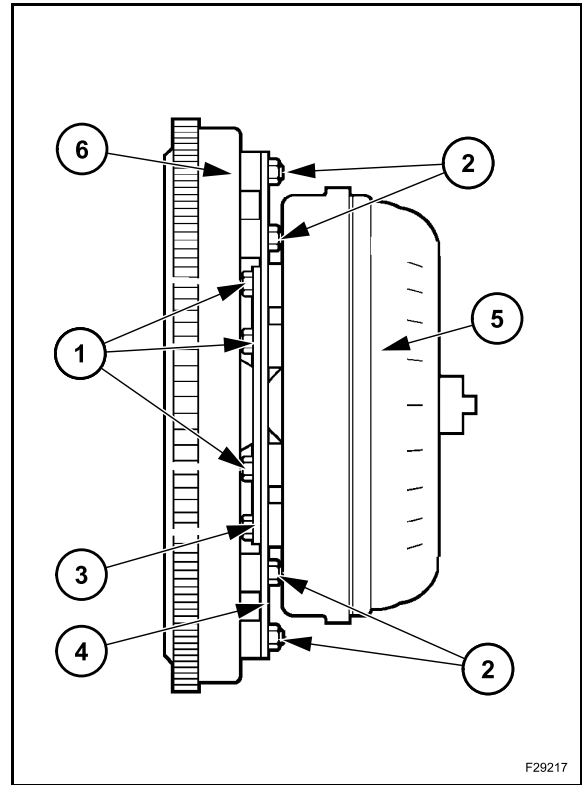

### 1.6 STALL TEST

The purpose of this test is to determine if the torque converter and hydraulic clutch assemblies are operating satisfactorily.

For the test to be conclusive, the transmission hydraulic pump and pressure regulating valve must be operating correctly.

They can be checked by performing the "Line Pressure Test".

The engine and brakes must also be in good working order.

- Check the coolant level in the radiator and the oil level in the transmission. If low, add fluid as required to bring to the proper level.
- With the gearshift lever and the shuttle lever in neutral, start the engine and run at 800-1000 revs/min until the transmission temperature reaches 29 °C - 35 °C.
- Lock the brakes and shift into fourth gear, increase engine speed to approximately 900 revs/min, then shift the power reversing lever to the forward position. This will position the control valve so as to direct high pressure oil to the front clutch.
- Ensure the brakes are firmly locked so the unit will not move, gradually depress the foot accelerator and note the maximum engine speed obtained. Move the power reversing lever to the neutral position. The stall speed should be:

Engine 95 HP ..... 1750 ÷ 1900 rev/min  
 Engine 110 HP ..... 1900 ÷ 2100 rev/min

---

**IMPORTANT:** to prevent the transmission from overheating, do not allow the engine to operate at wide open throttle for more than fifteen seconds.

---

- Allow the transmission oil to cool to 29° - 35° C. Check the rear hydraulic clutch by repeating previous steps, but with the power reversing lever in the rearward position. Again, cool the transmission oil by allowing the engine to run at approximately 1000 revs/min for one minute.
  - The engine speed noted previously (stall speed) for both the front and rear clutch assemblies should be within 150 revs/min of each other. If the stall speed is not within these limits, refer to the diagnosis guide for possible causes.
  - With the gearshift lever and power reversing lever in neutral, set the engine speed at 600-800 revs/min, then shift into any gear ratio. If the gears clash, either the front or rear hydraulic clutch assembly is transmitting power, even though the power reversing lever is in neutral.
- 

**NOTE:** if the unit creeps forward and the gears clash, the front clutch is at fault. The rear clutch is at fault if the unit creeps backward. If the unit does not creep and the gears still clash, use the stabilizers to raise the rear wheels off the ground, move the power reversing lever to neutral and shift into first gear. Check the rear wheels for rotational direction - if the wheel rotate rearward, then the rear clutch is at fault.

---

## 1.7 FAULT FINDING

PROBLEM	CAUSE	ACTION
Low stall speed	Hydraulic clutch not releasing Stator support broken Defective torque converter Low engine power	Replace torque converter. Replace torque converter. Replace torque converter. Check and correct output.
High stall speed	Hydraulic clutch not applying or is slipping Low line pressure Sealing rings on rear input shaft broken Defective torque converter	Replace.  Check pump output.  Replace seals. Replace torque converter.

(See section "TRANSMISSION" chapter "TRANSMISSION HYDRAULIC VALVES AND PRESSURE TEST POINTS" at page 18)

---

## 2. POWERSHIFT TORQUE CONVERTER

### 2.1 DESCRIPTION AND OPERATION

Engine power is transmitted from the engine flywheel to the impeller through the impeller cover.

This element is the pump portion of the hydraulic torque converter and is the primary component which starts the oil flowing to the other components which results in torque multiplication. This element can be compared to a centrifugal pump in that it picks up fluid at its centre discharges at its outer diameter. The torque converter turbine is mounted opposite the impeller and is connected to the turbine shaft or directional clutch shaft. This element receives fluid at its outer diameter and discharges at its centre. The stator of the torque converter is located between and at the centre of the inner diameters of the impeller and turbine elements. Its function is to take the fluid which is exhausting from the inner portion of the turbine and change its direction to allow correct entry for recirculation into the impeller element. This recirculation will make the converter to multiply torque. The torque multiplication in function of the balding (impeller, turbine and stator) and the converter output speed (turbine speed). The converter will multiply engine torque to its designed maximum multiplication ratio when the turbine shaft is at zero RPM (stall). Therefore we can say that as the turbine shaft is decreasing in speed, the torque multiplication is increasing. In the impeller cover a splined shaft is fitted which runs inside and through the turbine shaft to drive a hydraulic pump which is fitted at the back of the transmission. Since the shaft is connected to the centre of the impeller cover, the pump speed will be the same as engine speed. The rear side of the impeller cover has a tanged drive which drives the transmission charging pump located in the converter housing. The transmission charging pump speed is also the same as the engine speed.

### TORQUE CONVERTER AND LUBRICATION PRESSURE TEST PORTS

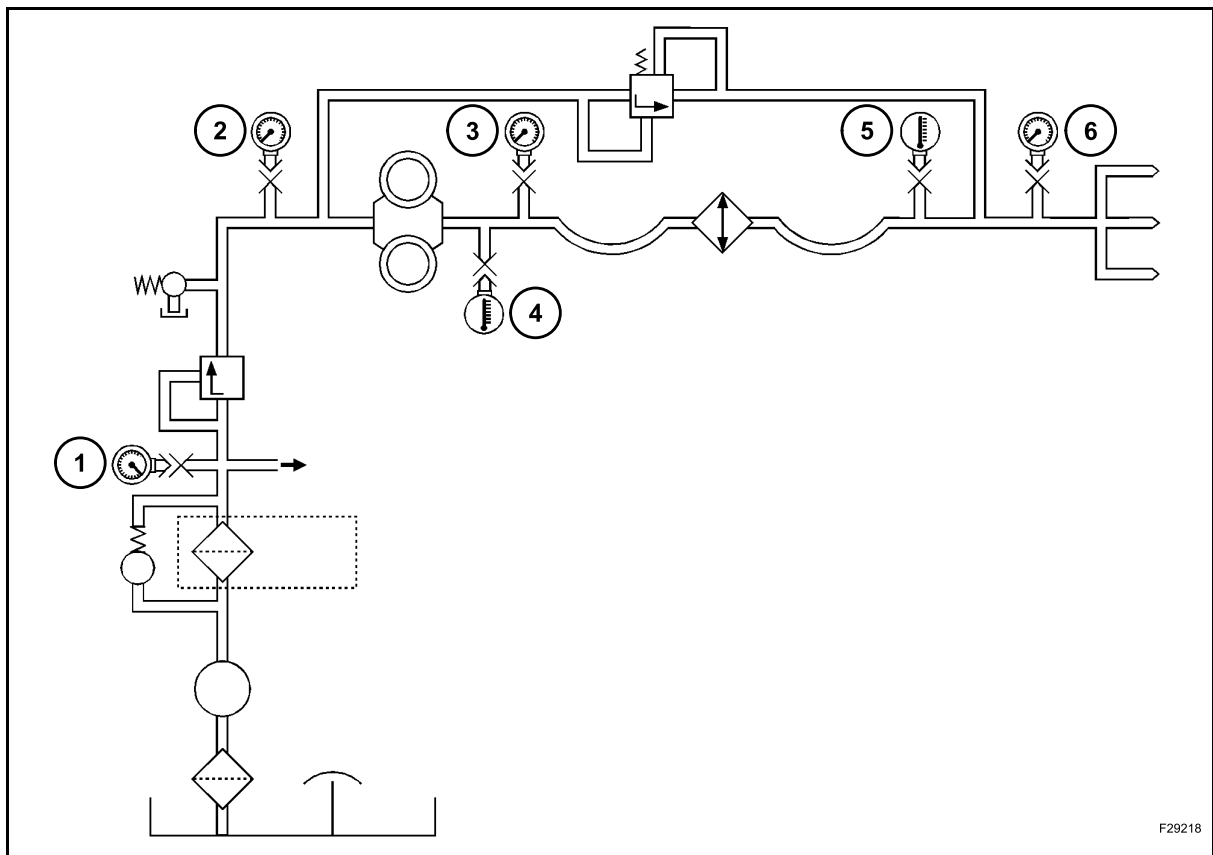

1. System pressure port
2. Torque converter in port
3. Torque converter out port

4. Oil temperature converter out port
5. Oil temperature cooler out port
6. Lubrication pressure port

(See section "TRANSMISSION" chapter "PRESSURE SPECIFICATIONS AND CHECK POINTS" at page 106)

## 2.2 TECHNICAL SPECIFICATIONS

Torque converter ratio.....	2.38:1
Torque of retaining screws for transmission .....	26 Nm
Torque of retaining screw for flywheel .....	43 Nm
Torque of screw for drive plate.....	43 Nm

### Hydraulic tests

Tachometer setting .....	2200 revs/min
Test temperature, oil .....	82-93 °C
Torque converter relief valve.....	10 bar
Oil temperature converter out:	
Normal operating range .....	80-90 °C
Maximum temperature .....	120 °C

## 2.3 OVERHAUL

The torque converter, is a welded unit and cannot be disassembled. The only maintenance performed on the converter, other than the stall test, is cleaning and visual inspection. A commercial torque converter cleaner may be used to clean the converter. However, if a commercial cleaner is not available, the converter should be cleaned as outlined below.

- Drain as much oil as possible from the hub of the converter by tilting the converter in all directions.
- Fill the converter about half full, through the hub (1), with paraffin base solvent or any cleaning solvent specified for cleaning transmissions.
- Plug the opening in the hub, then circulate the solvent inside the converter by rotating and shaking.
- Drain the solvent from the converter.
- Repeat previous steps, as required, until the solvent that is drained from the converter is clean.

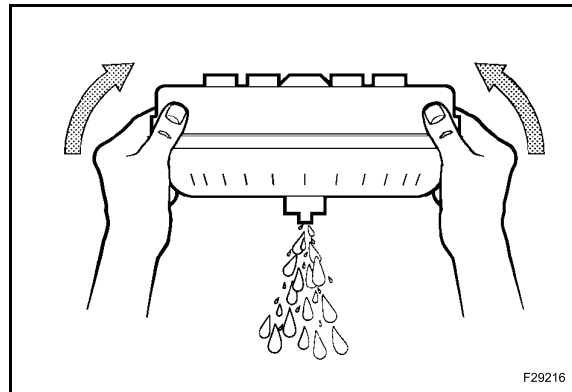
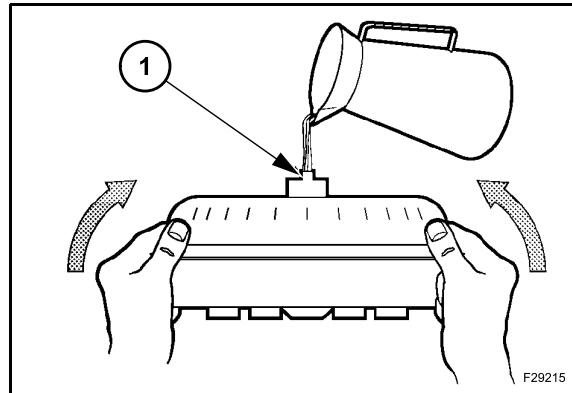

## 2.4 INSPECTION

Inspect the splines on the converter hub for wear or damage and the weld joints for cracks. If the hub is worn or damaged and/or the weld joints cracked, a new converter must be installed. A new drive plate should also be installed if it is warped.

## 2.5 DISASSEMBLY AND ASSEMBLY

### DISASSEMBLY

Remove drive plate screws.

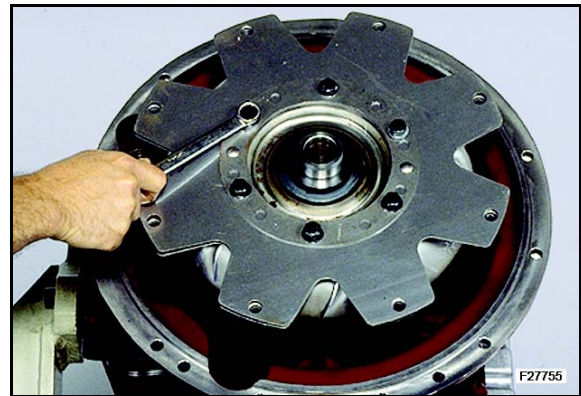

Remove drive plates.

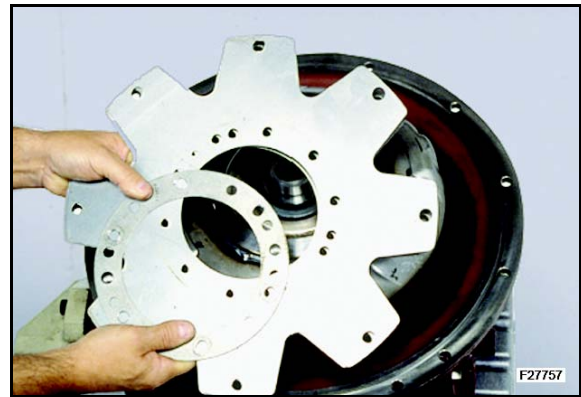

Remove torque converter.

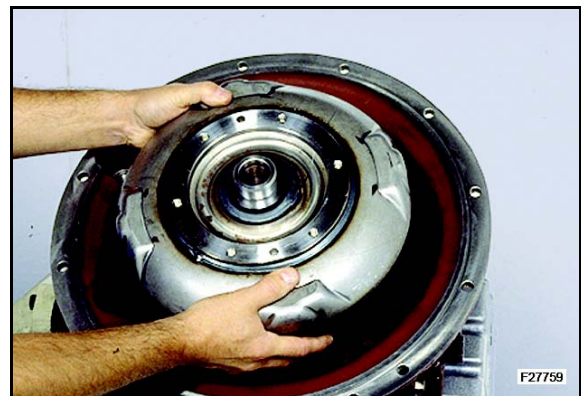

**ASSEMBLY**

Install converter assembly on input shaft.

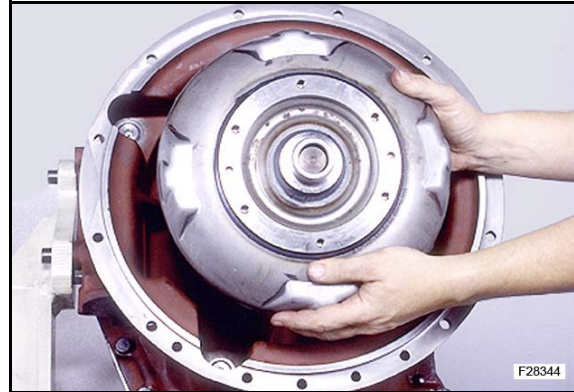

Install drive plates on converter.

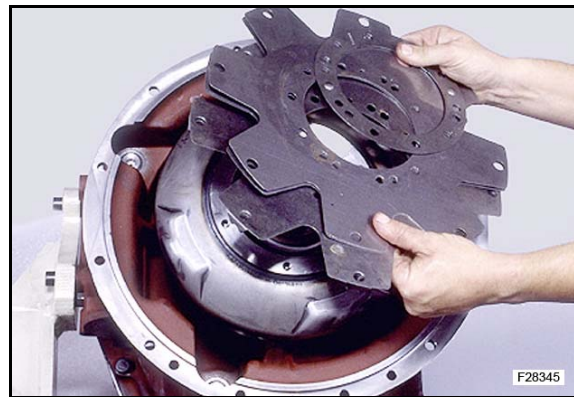

Install drive plates screws and lock washers and tighten screws to specified torque 43 Nm.

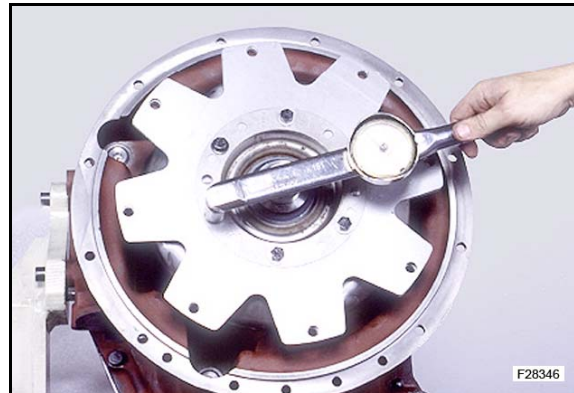

## 2.6 STALL TEST

The purpose of this test is to determine if the torque converter and hydraulic clutch assemblies are operating satisfactorily.

For the test to be conclusive, the transmission hydraulic pump and pressure regulating valve must be operating correctly.

They can be checked by performing the "Line Pressure Test".

The engine and brakes must also be in good working order.

- Check the coolant level in the radiator and the oil level in the transmission. If low, add fluid as required to bring to the proper level.
- With the gearshift lever and the shuttle lever in neutral, start the engine and run at 800-1000 revs/min until the transmission temperature reaches 29 °C - 35 °C.
- Lock the brakes and shift into fourth gear, increase engine speed to approximately 900 revs/min, then shift the power reversing lever to the forward position. This will position the control valve so as to direct high pressure oil to the front clutch.
- Ensure the brakes are firmly locked so the unit will not move, gradually depress the foot accelerator and note the maximum engine speed obtained. Move the power reversing lever to the neutral position. The stall speed should be:

Engine 95 HP ..... 1750 ÷ 1900 rev/min

Engine 110 HP ..... 1950 ÷ 2200 rev/min

**IMPORTANT:** to prevent the transmission from overheating, do not allow the engine to operate at wide open throttle for more than fifteen seconds.

- Allow the transmission oil to cool to 29 °C - 35 °C. Check the rear hydraulic clutch by repeating previous steps, but with the power reversing lever in the rearward position. Again, cool the transmission oil by allowing the engine to run at approximately 1000 revs/min for one minute.
- The engine speed noted previously (stall speed) for both the front and rear clutch assemblies should be within 150 revs/min of each other. If the stall speed is not within these limits, refer to the diagnosis guide for possible causes.
- With the gearshift lever and power reversing lever in neutral, set the engine speed at 600-800 revs/min, then shift into any gear ratio. If the gears clash, either the front or rear hydraulic clutch assembly is transmitting power, even though the power reversing lever is in neutral.

---

**NOTE:** if the unit creeps forward and the gears clash, the front clutch is at fault. The rear clutch is at fault if the unit creeps backward. If the unit does not creep and the gears still clash, use the stabilizers to raise the rear wheels off the ground, move the power reversing lever to neutral and shift into first gear. Check the rear wheels for rotational direction - if the wheel rotate rearward, then the rear clutch is at fault.

---

**2.7 FAULT FINDING**

<b>PROBLEM</b>	<b>CAUSE</b>	<b>ACTION</b>
Low stall speed	Hydraulic clutch not releasing Stator support broken Defective torque converter Low engine power	Replace torque converter. Replace torque converter. Replace torque converter. Check and correct output.
High stall speed	Hydraulic clutch not applying or is slipping Low line pressure Sealing rings on rear input shaft broken Defective torque converter	Replace.  Check pump output.  Replace seals. Replace torque converter.

(See section "TRANSMISSION" chapter "PRESSURE SPECIFICATIONS AND CHECK POINTS" at page 106)

**580 Super R**  
**590 Super R**  
**695 Super R**

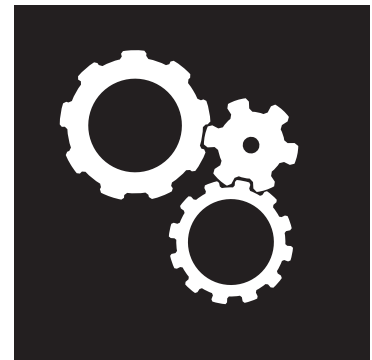

## SECTION 21 - TRANSMISSION

1. POWERSHUTTLE TRANSMISSION “TURNER MODEL COM-T4-2025” .....	3
1.1 TECHNICAL SPECIFICATIONS.....	3
1.2 TIGHTENING TORQUES .....	5
1.3 TRANSMISSION CONTROLS.....	6
1.4 LUBRICATION.....	11
1.5 TRANSMISSION OIL FLOW AND SUPPLY.....	12
1.6 TRANSMISSION HYDRAULIC VALVES AND PRESSURE TEST POINTS.....	18
1.7 TRANSMISSION POWER FLOW.....	19
1.8 TRANSMISSION 2WD COMPONENTS.....	23
1.9 TRANSMISSION 4WD COMPONENTS.....	26
1.10 TRANSMISSION REMOVAL.....	31
1.11 DISASSEMBLY AND ASSEMBLY.....	32
1.12 FAULT FINDING.....	90
1.13 SPECIAL TOOLS.....	93
2. POWERSHIFT TRANSMISSION “DANA T16000” .....	94
2.1 TECHNICAL SPECIFICATIONS.....	94
2.2 TRANSMISSION CONTROLS.....	95
2.3 LUBRICATION.....	105
2.4 PRESSURE SPECIFICATIONS AND CHECK POINTS.....	106
2.5 TRANSMISSION COOLER .....	108
2.6 TRANSMISSION HYDRAULIC DIAGRAM.....	109
2.7 OPERATION.....	110
2.8 POWER FLOWS.....	117
2.9 GEAR AND CLUTCH LAY OUT .....	132
2.10 TRANSMISSION / ENGINE REMOVAL FROM LOADER.....	133
2.11 TRANSMISSION COMPONENTS.....	137
2.12 DISASSEMBLY AND ASSEMBLY.....	155
2.13 SPECIAL TOOLS.....	264
2.14 FAULT FINDING.....	265
2.15 FAULT FINDING.....	267

## 1. POWERSHUTTLE TRANSMISSION “TURNER MODEL COM-T4-2025”

This transmission is used on Powershuttle loader backhoes models 580 Super R and 590 Super R. The transmission consists of a torque converter, an internal rotor-type hydraulic pump, an oil distributor, a solenoid control valve assembly, two hydraulically operated clutches, a 4-speed synchromesh geartrain, transmission case and oil cooler tubes.

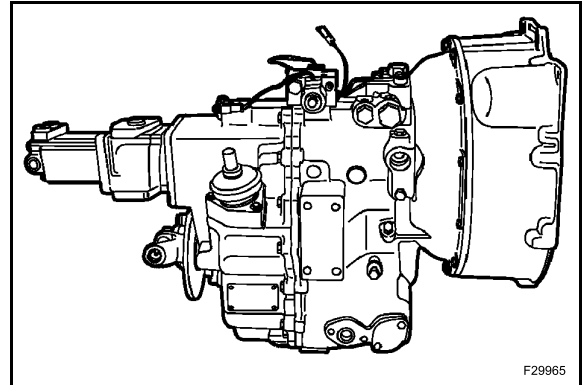

**NOTE:** a conventional clutch is not used with this transmission.

The transmission case serves as an oil tank for the torque converter and hydraulic clutch assemblies. The transmission receives power from the engine (1) by a fluid coupling in the torque converter (2) and hydraulic clutch assemblies in the transmission (3).

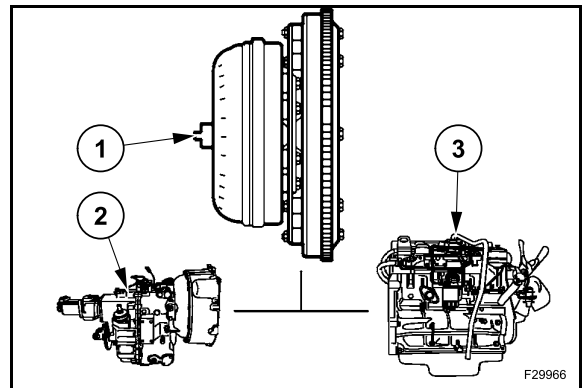

### 1.1 TECHNICAL SPECIFICATIONS

#### GEAR RATIO

Forward				Reverse			
1	2	3	4	1	2	3	4
4.824	2.998	1.408	0.792	4.020	2.496	1.173	0.660

#### COLD START BY-PASS VALVE SPRING

Free length..... 53.4 mm ± 0.96 mm

#### FORWARD CLUTCH SPRING

Free length..... 76.6 mm

#### CLUTCH PISTON SPRING

Free length..... 75.9 mm

#### DETENT SPRING

Free length (Approximately)..... 42.06 mm

**END FLOAT**

Input forward Primary Shaft .....	0.0508-0.41 mm
Input reverse Primary Shaft .....	0.0508-0.41 mm
Output shaft.....	1st Gear - 0.33-0.508 mm
.....	2nd Gear - 0.35-0.558 mm
.....	3rd Gear - 0.38-0.838 mm
.....	4th Gear - 0.20-0.558 mm
Four Wheel Drive Shaft.....	0.050-0.28 mm
Bearing End Floats.....	0.025-0.076 mm
Bearing End Float Shims available .....	0.050/0.076/0.127/0.177/0.381/0.508 mm

**HYDRAULIC TESTS**

Tachometer Setting .....	2000 revs/min
Test temperature, oil .....	80-85 °C
Cold Start Valve (For reference only).....	26 bar
System Pressure Test.....	13.7-15.2 bar
Torque Converter .....	7-11 bar
Reverse Clutch.....	13.7-15.2 bar
Forward Clutch.....	13.7-15.2 bar
Four Wheel Drive Supply .....	13.7-15.2 bar

**COOLER FLOW TEST**

Oil temperature 80-85 °C .....	Revs/min .....	Oil Flow Litres/min
.....	700 .....	12.5 litres
.....	1000 .....	18.2 litres
.....	1500 .....	22.1 litres
.....	2000 .....	24.0 litres
.....	2200 .....	24.5 litres
.....	2500 .....	25.0 litres

**1.2 TIGHTENING TORQUES**

Strainer bolts .....	18 to 31 Nm
Pump retaining bolts .....	18 to 31 Nm
Output Yoke bolts .....	68 to 88 Nm
Pressure test plugs .....	41 to 54 Nm
Main transmission case bolts .....	45 to 64 Nm
Shift detent plug .....	41 to 54 Nm
Shift fork screws .....	18 to 25 Nm
Shift lever assembly screws .....	16 to 24 Nm
Drain plugs .....	34 to 54 Nm
Converter relief valve .....	23 to 30 Nm
Pressure regulator valve .....	46 to 60 Nm
Cold start valve .....	46 to 60 Nm
4WD solenoid valve spool .....	20 to 27 Nm
4WD Solenoid coil retaining nut .....	5.4 Nm
Directional control valve retaining screws .....	6.8 to 8.5 Nm
4WD hydraulic pipe connections .....	6.8 to 10.2 Nm
Filter housing bolts .....	45 to 64 Nm
Oil filter .....	7 to 10 Nm
Temperature sender .....	20 to 27 Nm

**RECOMMENDED SEALANTS**

Transmission case joint .....	Loctite 5203
4wd Output gear .....	Loctite 649
4wd gear (Permanent 4wd assy) .....	Loctite 649
4wd clutch supply pipe .....	Loctite 542
Gear lever housing .....	Loctite 5900 RTV
Shimming access expansion plug .....	Loctite 649

## 1.3 TRANSMISSION CONTROLS

## 4X4 POWERSHUTTLE TRANSMISSION CONTROLS

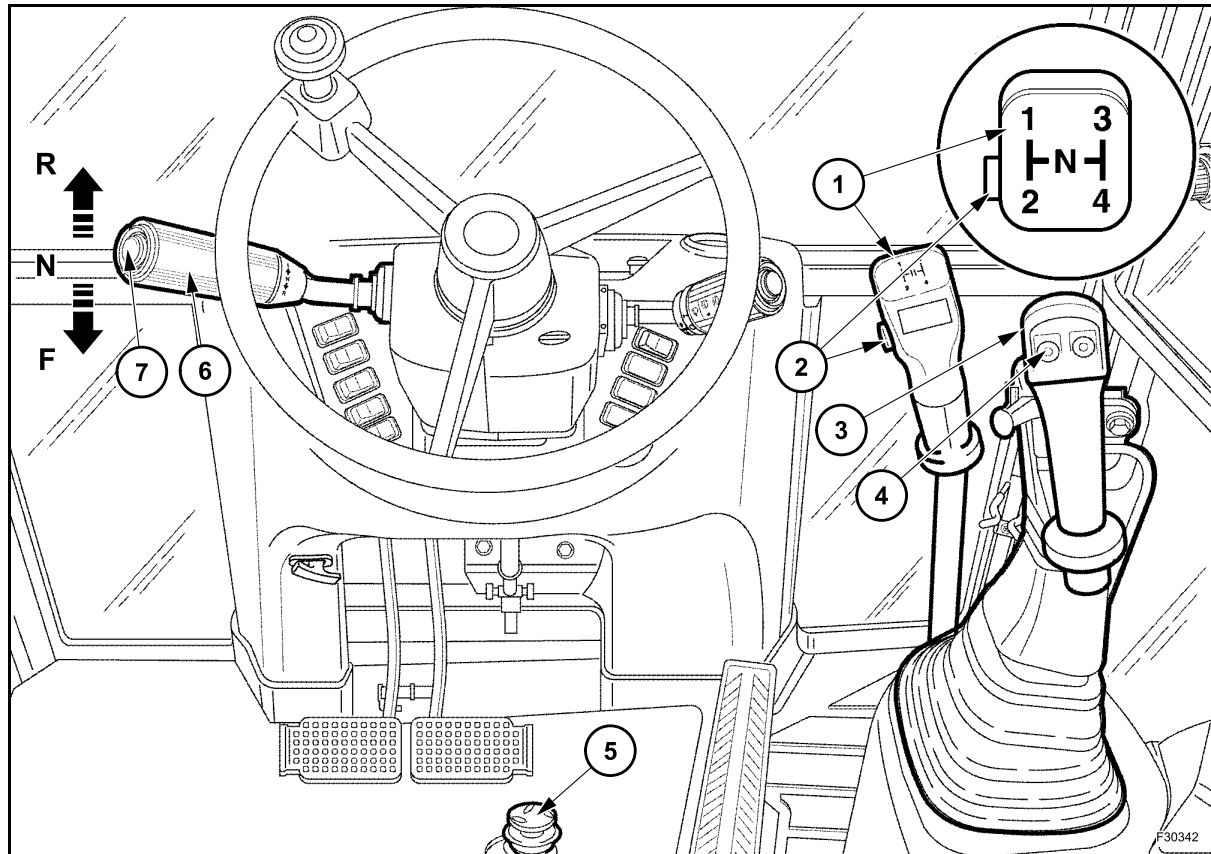

1. GEAR LEVER: Four gears are selectable for the required ground speeds in both forward or reverse travel.
2. TRANSMISSION DISCONNECT BUTTON (On gear level): Prior to changing gear depress and hold down this switch which disengages transmission drive, select the required gear with the gear lever and release the switch to re-engage drive.
3. LOADER ATTACHMENT CONTROL LEVER
4. TRANSMISSION DISCONNECT BUTTON: (On loader attachment control lever) This button is used to disengage the transmission in order to increase loader attachment power.
5. MECHANICAL DIFFERENTIAL LOCK PEDAL: Depressing this pedal will lock both rear wheels together giving equal drive and will disengage when wheel torque equalises or foot brakes are applied.
6. TRANSMISSION POWERSHUTTLE DIRECTION LEVER: Movement of this lever from the neutral position will engage forward or rearward travel and will cause the audible warning device to sound.

---

**NOTE:** in reverse gear an audible alarm device sounds.

---

7. WARNING HORN BOTTON



**Suggest:**

**If the above button click is invalid.**

**Please download this document**

**first, and then click the above link**

**to download the complete manual.**

**Thank you so much for reading**

### Transmission

The transmission is fully synchronised providing four forward and four reverse speeds allowing gear ratio changes on the move. A torque converter is used to connect the engine to the transmission and the column mounted powershuttle lever (4) enables shifts between forward and reverse travel without disengaging gear ratios.

A "Transmission disconnect" feature is provided by finger operated buttons (2) on both the main gearshift lever (1) and loader control lever (3) of which disengages drive to the transmission to enable on the move gear changing.

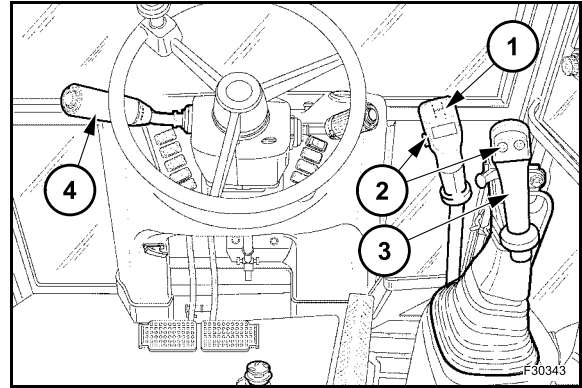

### ⚠ WARNING

Always apply the parking brake whenever the machine is parked as the machine is free to roll even though the transmission gearshift lever and power reversing lever may be "In Gear" and the engine is turned "OFF".

### Gear Shift Lever

The single gearshift lever (1) is used to select any one of the four gear ratios. The transmission disconnect button (2) is depressed and held as the lever is shifted from one gear to another and then released to re-connect transmission drive.

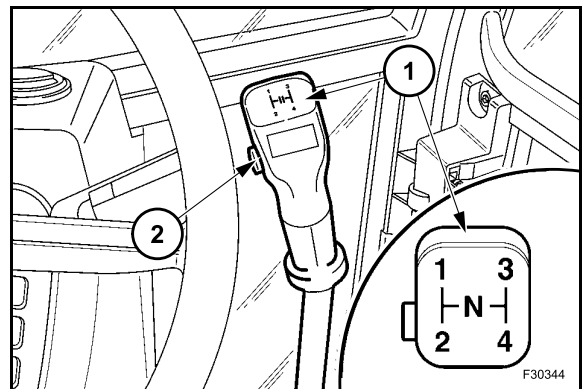

**<https://www.ebooklibonline.com>**

Hello dear friend!

Thank you very much for reading.

Enter the link into your browser.

The full manual is available for immediate download.

**<https://www.ebooklibonline.com>**