

SERVICE MANUAL
Loader / Backhoe
M
Series
2

6-74432

1. Trim along dashed line.
2. Slide into pocket on Binder Spine.

TYPE 1-4

SERVICE MANUAL
Loader / Backhoe
M
Series
2

6-74432

1. Trim along dashed line.
2. Slide into pocket on Binder Spine.

TYPE 1-4

SERVICE MANUAL
Loader / Backhoe
M
Series
2

6-74432

1. Trim along dashed line.
2. Slide into pocket on Binder Spine.

TYPE 1-4

SERVICE MANUAL
Loader / Backhoe
M
Series
2

6-74432

1. Trim along dashed line.
2. Slide into pocket on Binder Spine.

TYPE 1-4

M SERIES 2 LOADER/BACKHOE

Service Manual

Bur 6-74432

Table of Contents

Description	Section Number	Publication Form Number
General		Tab 1
Section Index - General		6-74450
Standard Torque Specifications	1001	8-71603
Fluids and Lubricants	1002	6-74461
Metric Conversion Chart	1003	7-52950
Engine		Tab 2
Section Index - Engine		6-74470
Engine and Radiator Removal and Installation	2000	6-74481
Stall Test	2002	6-74492
In Vehicle Injector Pump Removal and Installation	2445	6-79380
Counter Balance Removal and Installation	2447	6-74700
Engine Service Manual		6-74500
Fuel System		Tab 3
Section Index - Fuel System		6-74510
<i>NOTE: For Fuel System Repair See Engine Service Manual.</i>		
Electrical		Tab 4
Section Index - Electrical		6-74520
Removal and Installation of Electrical Components	4000	6-74530
Electrical Specifications and Troubleshooting	4001	6-74541
Batteries	4003	6-74550
Starter and Starter Solenoid	4004	6-74560
Instrument Cluster	4005	6-74570

Reprinted

M SERIES 2 LOADER/BACKHOE

Service Manual

Bur 6-74432

Table of Contents (Continued)

Description	Section Number	Publication Form Number
Steering		Tab 5
Section Index - Steering		6-74590
Removal and Installation of Steering Components	5000	6-74600
Steering Specification, Pressure Checks and Troubleshooting	5001	6-74610
Steering Control Valve	5002	6-74621
Steering Cylinders	5003	6-74630
Front Axle - Two Wheel Drive	5005	6-74640
Front Axle - Four Wheel Drive 580M, 580SM, and 580SM+	5006	6-74650
Front Axle - Four Wheel Drive 590SM	5006	6-74670
Power Train		Tab 6
Section Index - Power Train		6-74680
Removal and Installation of Power Train Components	6000	6-74690
Standard Transmission Specifications, Pressure Checks, and Troubleshooting	6002	6-74710
Power Shift Transmission Specifications, Pressure Checks, and Troubleshooting	6002	6-74720
Wheels and Tires	6003	6-74730
Rear Axle and Planetaries - 580M, 580SM, and 580SM+	6004	6-74751
Rear Axle and Planetaries - 590SM	6004	6-74770
Standard Transmission	6007	6-74782
Power Shift Transmission	6007	6-74790
Brakes		Tab 7
Section Index - Brakes		6-74800
Removal and Installation of Brake Components	7000	6-74810
Hydraulic Brake Troubleshooting	7002	6-74820
Master Cylinder	7003	6-74830
Hydraulics		Tab 8
Section Index - Hydraulics		6-74842
Removal and Installation of Hydraulic Components	8001	6-74850
Removal and Installation of Hydraulic Components 590SM With Pilot Controls	8001	6-74761
Hydraulic System Specifications and Troubleshooting With Mechanical Controls	8002	6-74862
Hydraulic System Specifications and Troubleshooting 580M, 580SM, and 580SM+ With Pilot Controls	8002	6-74872
Hydraulic System Specifications and Troubleshooting 590SM With Pilot Controls	8002	6-74741
Cleaning the Hydraulic System	8003	6-74880
Hydraulic Pump 580SM, 580SM+ (all versions), and 590SM With Mechanical Controls	8004	6-74900

<https://www.ebooklibonline.com>

Hello dear friend!

Thank you very much for reading.

Enter the link into your browser.

The full manual is available for immediate download.

<https://www.ebooklibonline.com>

M SERIES 2 LOADER/BACKHOE Service Manual Bur 6-74432

Table of Contents (Continued)

Description	Section Number	Publication Form Number
Hydraulics (Cont)		Tab 8
Hydraulic Pump 590SM With Pilot Controls	8004	6-80010
Loader Control Valve 580M, 580SM 580SM+ (all versrions), and 590SM With Mechanical Controls	8005	6-74912
Loader Control Valve 590SM With Pilot Controls	8005	6-79930
Cylinders	8006	6-74920
Backhoe Control Valve With Mechanical Controls	8007	6-74931
Backhoe Control Valve With Pilot Controls 580M, 580SM and 580SM+	8007	6-74941
Backhoe Control Valve With Pilot Controls 590SM	8007	6-79940
Accumulator for Machines With Ride Control and Pilot Control Accumulator	8009	6-74960
Solenoid Valve for Machines with Optional Ride Control	8010	6-74970
Boom Lock Solenoid Valve	8011	6-74980
Quick Coupler	8012	6-74990
Swing Dampening Valve	8013	6-75000
Pilot Control Unit	8014	6-79950
Proportional Pilot Pressure Control	8015	6-79960
Mounted Equipment		Tab 9
Section Index - Mounted Equipment		6-75011
Pedals and Levers	9001	6-75020
Air Conditioning Troubleshooting	9002	6-75031
Air Conditioning System Service	9004	6-75051
Air Conditioning Components Service	9005	6-75061
Loader	9006	6-75070
ROPS Cab and Canopy	9007	6-75080
Backhoe	9008	6-75090
Standard and Mechanical Suspension Seat	9009	6-75100
Sears Mechanical and Standard Suspension Seat	9009	6-80000
Air Suspension Seat	9010	6-75111
Rear Window Replacement	9012	6-75040
Schematic Set		
Hydraulic and Electrical Schematics	In Rear Pocket	6-75122

NOTE: CNH Corporation reserves the right to make improvements in design or changes in specifications at any time without incurring any obligation to install them on units previously sold.

Section 1001

GENERAL TORQUE SPECIFICATIONS

TORQUE SPECIFICATIONS - DECIMAL HARDWARE

Use the torques in this chart when special torques are not given. These torques apply to fasteners with both UNC and UNF threads as received from suppliers dry, or when lubricated with engine oil. Not applicable if special graphities, Molydisulfide greases, or other extreme pressure lubricants are used.

Grade 5 Bolts, Nuts, and Studs		
		
Size	Pound-Inches	Newton metres
1/4 inch	108 to 132	12 to 15
5/16 inch	204 to 252	23 to 28
3/8 inch	420 to 504	48 to 57
Size	Pound-Feet	Newton metres
7/16 inch	54 to 64	73 to 87
1/2 inch	80 to 96	109 to 130
9/16 inch	110 to 132	149 to 179
5/8 inch	150 to 180	203 to 244
3/4 inch	270 to 324	366 to 439
7/8 inch	400 to 480	542 to 651
1.0 inch	580 to 696	787 to 944
1-1/8 inch	800 to 880	1085 to 1193
1-1/4 inch	1120 to 1240	1519 to 1681
1-3/8 inch	1460 to 1680	1980 to 2278
1-1/2 inch	1940 to 2200	2631 to 2983

Grade 8 Bolts, Nuts, and Studs		
		
Size	Pound-Inches	Newton metres
1/4 inch	144 to 180	16 to 20
5/16 inch	288 to 348	33 to 39
3/8 inch	540 to 648	61 to 73
Size	Pound-Feet	Newton metres
7/16 inch	70 to 84	95 to 114
1/2 inch	110 to 132	149 to 179
9/16 inch	160 to 192	217 to 260
5/8 inch	220 to 264	298 to 358
3/4 inch	380 to 456	515 to 618
7/8 inch	600 to 720	814 to 976
1.0 inch	900 to 1080	1220 to 1465
1-1/8 inch	1280 to 1440	1736 to 1953
1-1/4 inch	1820 to 2000	2468 to 2712
1-3/8 inch	2380 to 2720	3227 to 3688
1-1/2 inch	3160 to 3560	4285 to 4827

NOTE: Use thick nuts with Grade 8 bolts.

TORQUE SPECIFICATIONS - METRIC HARDWARE

Use the following torques when specifications are not given.

These values apply to fasteners with coarse threads as received from supplier, plated or unplated, or when lubricated with engine oil. These values do not apply if graphite or Molydisulfide grease or oil is used.

Grade 8.8 Bolts, Nuts, and Studs		
		
Size	Pound-Inches	Newton metres
M4	24 to 36	3 to 4
M5	60 to 72	7 to 8
M6	96 to 108	11 to 12
M8	228 to 276	26 to 31
M10	456 to 540	52 to 61
Size	Pound-Feet	Newton metres
M12	66 to 79	90 to 107
M14	106 to 127	144 to 172
M16	160 to 200	217 to 271
M20	320 to 380	434 to 515
M24	500 to 600	675 to 815
M30	920 to 1100	1250 to 1500
M36	1600 to 1950	2175 to 2600

Grade 10.9 Bolts, Nuts, and Studs		
		
Size	Pound-Inches	Newton metres
M4	36 to 48	4 to 5
M5	84 to 96	9 to 11
M6	132 to 156	15 to 18
M8	324 to 384	37 to 43
Size	Pound-Feet	Newton metres
M10	54 to 64	73 to 87
M12	93 to 112	125 to 150
M14	149 to 179	200 to 245
M16	230 to 280	310 to 380
M20	450 to 540	610 to 730
M24	780 to 940	1050 to 1275
M30	1470 to 1770	2000 to 2400
M36	2580 to 3090	3500 to 4200

Grade 12.9 Bolts, Nuts, and Studs

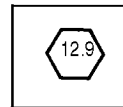

Usually the torque values specified for grade 10.9 fasteners can be used satisfactorily on grade 12.9 fasteners.

TORQUE SPECIFICATIONS - STEEL HYDRAULIC FITTINGS

Tube OD Hose ID	Thread Size	Pound- Inches	Newton metres
37 Degree Flare Fitting			
1/4 inch 6.4 mm	7/16-20	72 to 144	8 to 16
5/16 inch 7.9 mm	1/2-20	96 to 192	11 to 22
3/8 inch 9.5 mm	9/16-18	120 to 300	14 to 34
1/2 inch 12.7 mm	3/4-16	180 to 504	20 to 57
5/8 inch 15.9 mm	7/8-14	300 to 696	34 to 79
Tube OD Hose ID	Thread Size	Pound- Feet	Newton metres
3/4 inch 19.0 mm	1-1/16-12	40 to 80	54 to 108
7/8 inch 22.2 mm	1-3/16-12	60 to 100	81 to 135
1.0 inch 25.4 mm	1-5/16-12	75 to 117	102 to 158
1-1/4 inch 31.8 mm	1-5/8-12	125 to 165	169 to 223
1-1/2 inch 38.1 mm	1-7/8-12	210 to 250	285 to 338

Tube OD Hose ID	Thread Size	Pound- Inches	Newton metres
Straight Threads with O-ring			
1/4 inch 6.4 mm	7/16-20	144 to 228	16 to 26
5/16 inch 7.9 mm	1/2-20	192 to 300	22 to 34
3/8 inch 9.5 mm	9/16-18	300 to 480	34 to 54
1/2 inch 12.7 mm	3/4-16	540 to 804	57 to 91
Tube OD Hose ID	Thread Size	Pound- Feet	Newton metres
5/8 inch 15.9 mm	7/8-14	58 to 92	79 to 124
3/4 inch 19.0 mm	1-1/16-12	80 to 128	108 to 174
7/8 inch 22.2 mm	1-3/16-12	100 to 160	136 to 216
1.0 inch 25.4 mm	1-5/16-12	117 to 187	159 to 253
1-1/4 inch 31.8 mm	1-5/8-12	165 to 264	224 to 357
1-1/2 inch 38.1 mm	1-7/8-12	250 to 400	339 to 542

Split Flange Mounting Bolts		
Size	Pound- Inches	Newton metres
5/16-18	180 to 240	20 to 27
3/8-16	240 to 300	27 to 34
7/16-14	420 to 540	47 to 61
Size	Pound- Feet	Newton metres
1/2-13	55 to 65	74 to 88
5/8-11	140 to 150	190 to 203

Section 2000

ENGINE AND RADIATOR REMOVAL AND INSTALLATION

RADIATOR

Put identification tags on all disconnected hoses and wires. Close disconnected hoses and fittings with caps and plugs.

NOTE: *The photos in this procedure may be different from your machine and are for reference only.*

STEP 1



BD00G073

Park the machine on a level surface. Raise the loader and lock the support strut (1) to hold the loader. Stop the engine and apply the parking brake.

STEP 2

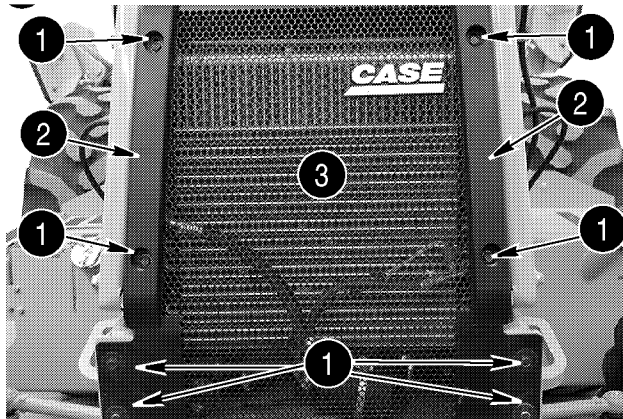

BD03K036

Remove the caps screws (1), bumpers (2), and the grille (3) from the front of the machine.

STEP 3

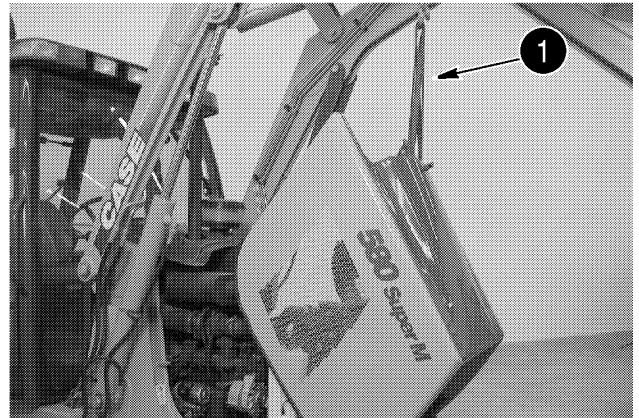

BD01B367

Open the hood. Connect acceptable lifting equipment to the hood (1).

STEP 4

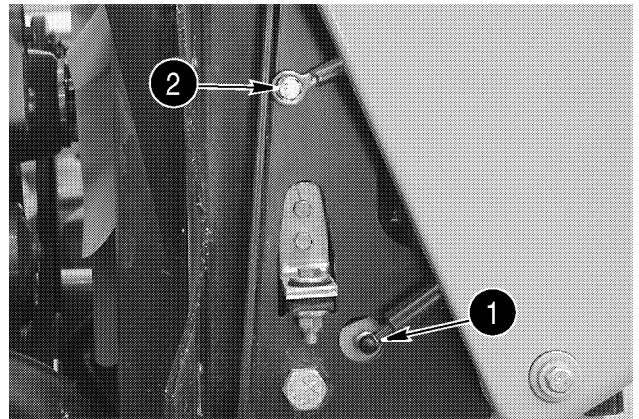

BD03K037

Do the following procedure to remove the hood.

- A. Remove the retainers from the hood struts (1) and disconnect the hood struts from the stud.
- B. Disconnect the hood cable (2) from the radiator shroud.
- C. Carefully lower the hood back to the closed position.

STEP 5

Remove the bolts, washers, and nuts from the pivot point on the hood.

STEP 6

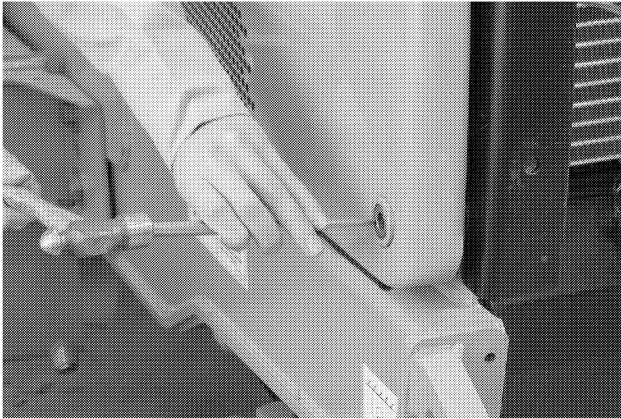

BD01B311

Drive the pivot tubes out of the hood pivot point. Remove the hood from the machine.

STEP 7

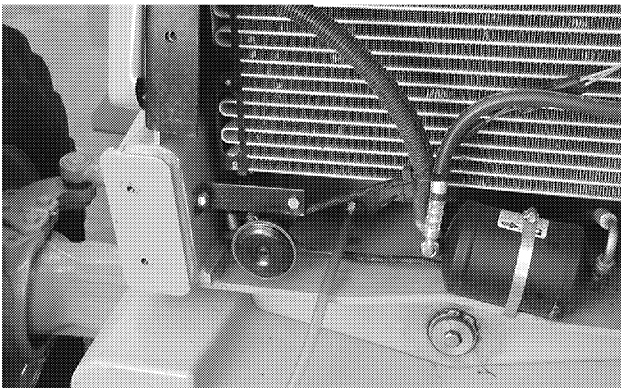

BD03K038

Slowly remove the radiator cap. Install a hose on the drain valve and drain the radiator into a clean container that holds approximately 17 liters (18 U.S. quarts).

NOTE: During installation, fill the radiator and deairiation reservoir to the full line. See Section 1002 for coolant specifications. Start and run the engine until the coolant is at operating temperature. Stop the engine and check for leakage. When the coolant is cold, check the coolant level. Add coolant as required.

STEP 8

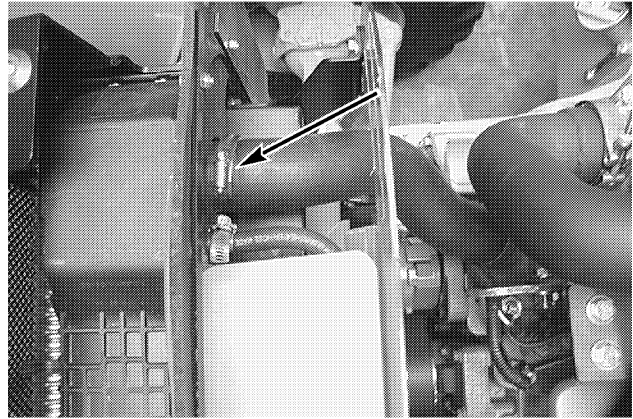

BS03K007

Loosen the clamp and disconnect the upper radiator hose.

STEP 9

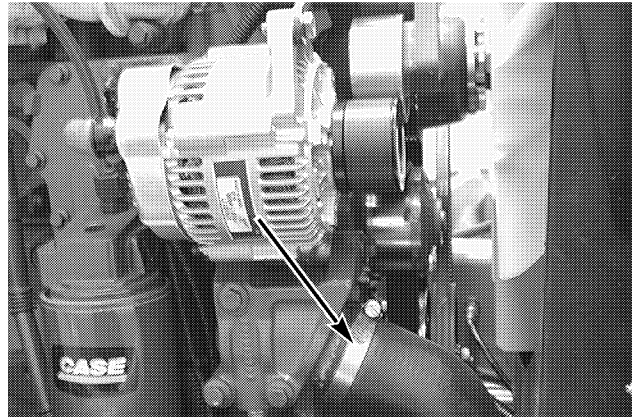

BP9502290

Loosen the clamp and disconnect the lower radiator hose.

STEP 10

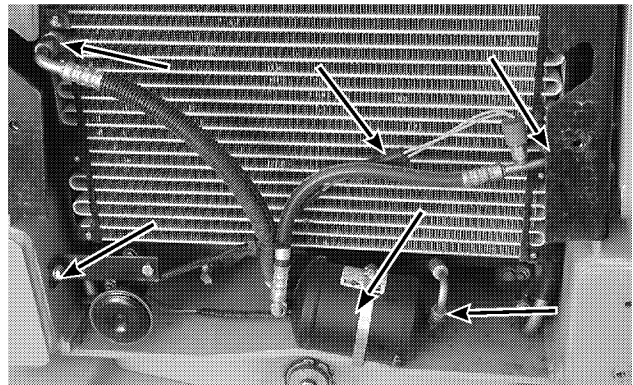

BD03K039

If equipped with air conditioning discharge air conditioning system, see section 9004. Disconnect high pressure switch, disconnect hoses from condenser and receiver drier. Remove the receiver drier and horn from the machine.

STEP 11

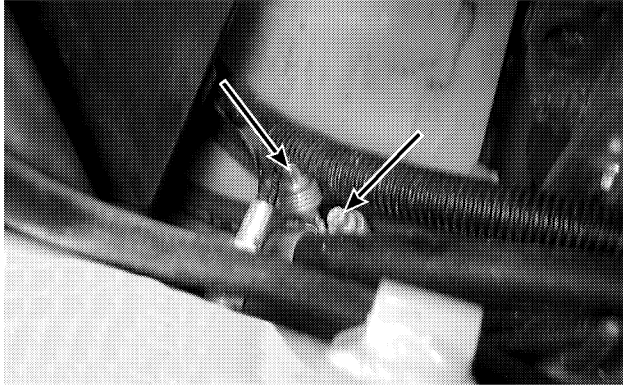

BD03K040

Disconnect all four oil cooler hoses, two on each side of the machine, from the oil cooler.

STEP 12

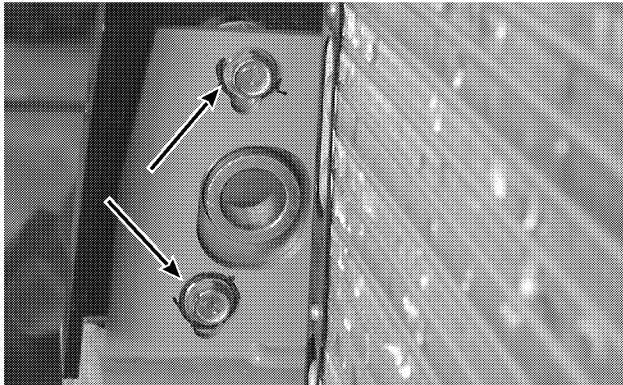

BD03K041

Mark the hood hinges for left and right. Mark the location of the hood hinge mounting bolts, remove the hood hinges from the frame.

STEP 13

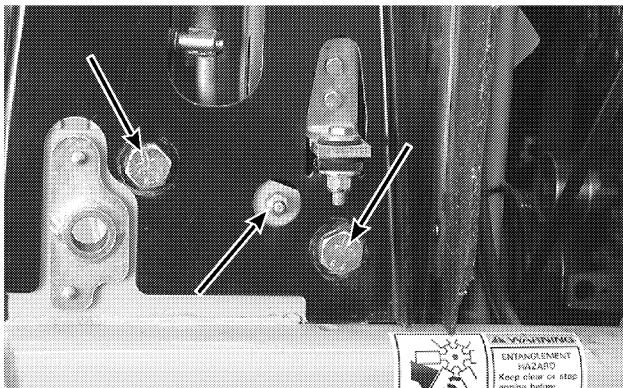

BD03K042

Remove the hood cylinder pivot pin and radiator wrapper mounting bolts.

NOTE: During installation insert mounting bolts finger tight, push wrapper toward rear of machine. Torque bolts to 251 to 447 Nm (185 to 330 lb-ft). Adjust fan shroud to obtain 5mm (0.8 in) clearance with the fan.

STEP 14

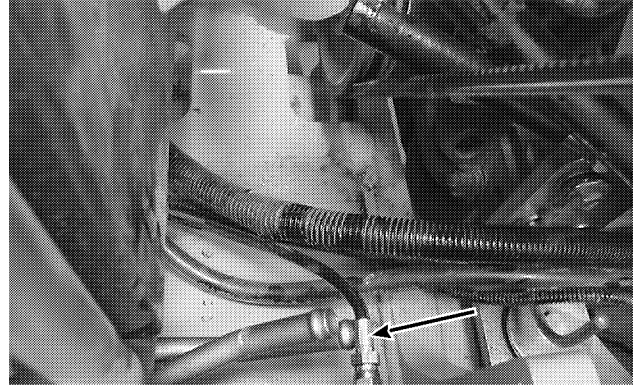

BD03K043

Attach suitable lifting equipment to the radiator wrapper. Raise the cooling pack just enough to move it forward and clear the oil cooler lines from the remote lubrication hose for the front axle.

STEP 15

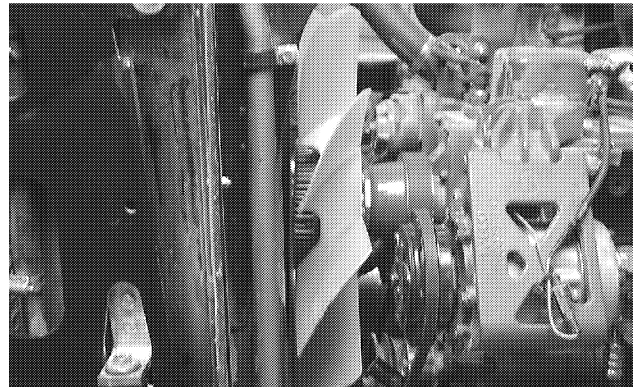

BD03K044

Make sure that you have cleared the fan from the shroud, raise the cooling pack from the machine.

NOTE: Installation of the radiator is the reverse of removal.

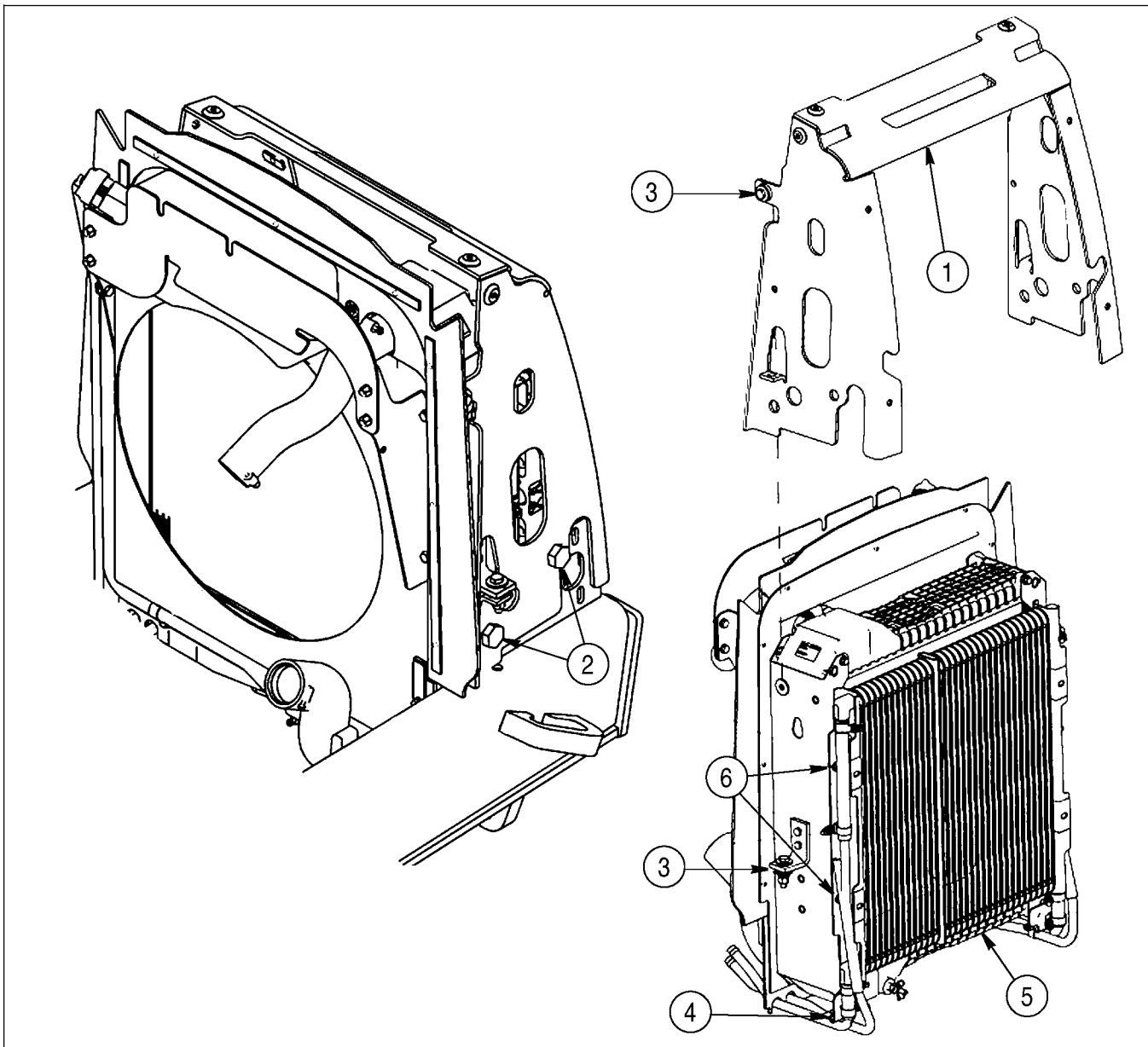

BC03K019

- | | |
|-------------------------------|---|
| 1. WRAPPER | 4. COOLER LINE MOUNTING BRACKETS (2) |
| 2. WRAPPER MOUNTING BOLTS (4) | 5. TRANSMISSION AND HYDRAULIC OIL COOLERS |
| 3. RADIATOR MOUNTS (4) | 6. OIL COOLER MOUNTING BOLTS (4) |

ILLUSTRATION OF RADIATOR MOUNTING

- Place cooling pack on a bench, remove the upper and lower radiator mounts (3), remove the lower "L" brackets from the radiator, remove wrapper (1).
- Remove the cooler line mounting brackets (4), remove the oil cooler mounting bolts (6).
- Lay the radiator on its side and remove the oil cooler (5) and if equipped the air conditioner condenser.
- Lay the radiator flat on the bench and remove the fan shroud and deairiation bottle from the radiator.

NOTE: During assembly torque the "L" bracket mounting bolts to 30 to 36 Nm (22 to 26 lb-ft). Torque lower mounts (3) to 13 to 25 Nm (10 to 18 lb-ft).

ENGINE

Put identification tags on all disconnected hoses and wires. Close disconnected hoses and fittings with caps and plugs.

NOTE: *The photos in this procedure may be different from your machine and are for reference only.*

STEP 1



BD00G073

Park the machine on a level surface. Raise the loader and lock the support strut to hold the loader.

STEP 2

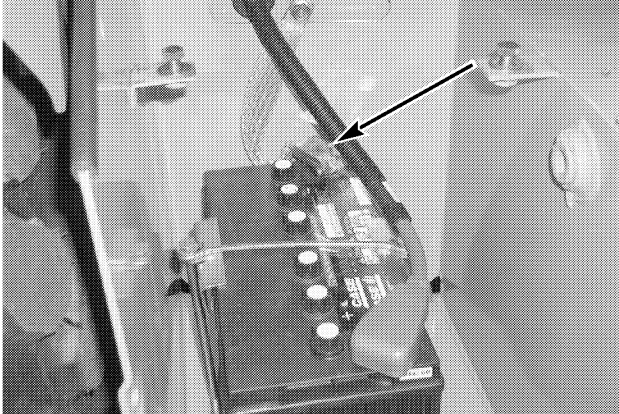

BD01B353

Remove the battery cover from the right step. If the machine has only one battery, disconnect the negative battery cable from the battery.

STEP 3

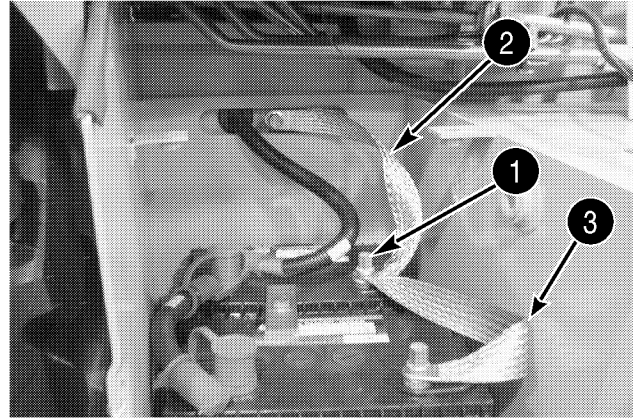

BD01B352

If the machine has two batteries, remove the terminal nut (1). Remove the negative battery cable (2) from the terminal and move the negative battery cable away from the battery. Make sure the jumper cable (3) is installed on the terminal and start the terminal nut (2) onto the terminal.

STEP 4

If the machine is equipped with air conditioning. See Section 9004 and discharge the air conditioning system.

NOTE: *During installation see Section 9004 and recharge the air conditioning system.*

STEP 5

Remove the radiator wrapper, fan shroud, radiator, oil coolers and if equipped with air conditioning the condenser as an assembly, see radiator removal this section.

STEP 6

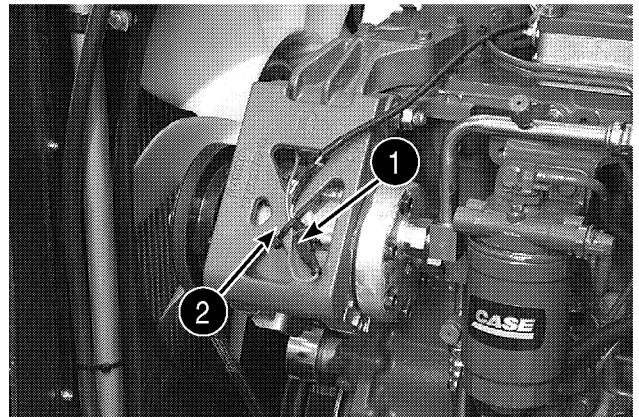

BS03K12

If the machine is equipped with air conditioning, disconnect the electrical connector (1). Remove the tie strap (2). Disconnect the hoses from the compressor.

STEP 7

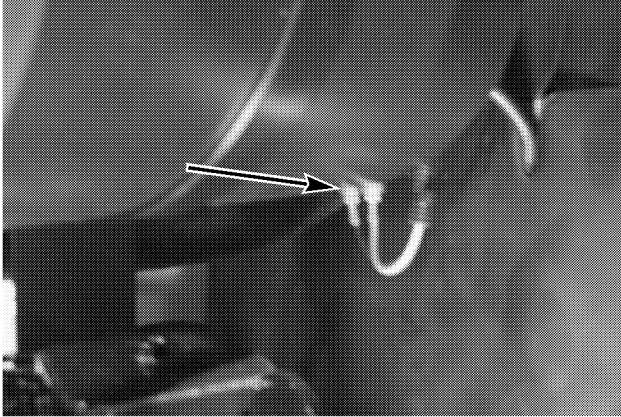

BD01B324

Remove the tie strap. Disconnect the electrical connectors for the air restriction indicator.

STEP 8

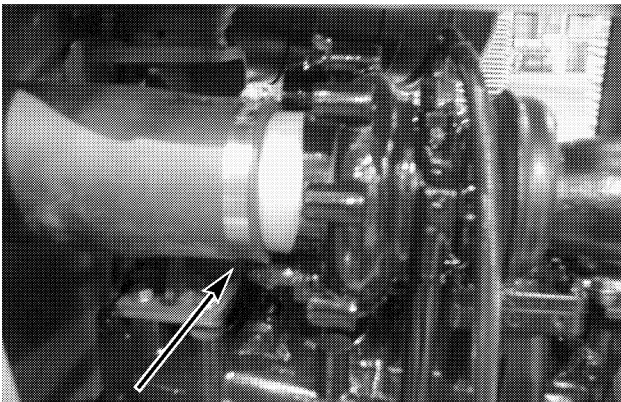

BD01B323

If the machine is equipped with turbocharger, loosen the clamp on the air cleaner hose at the turbocharger. Disconnect the air cleaner hose from the turbocharger.

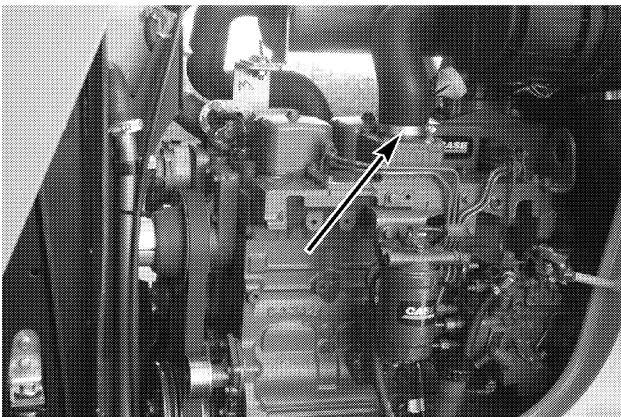

BD03K068

If the machine is not equipped with turbocharger, loosen the clamp on the air cleaner hose at the intake manifold. Disconnect the air cleaner hose from the intake manifold.

STEP 9

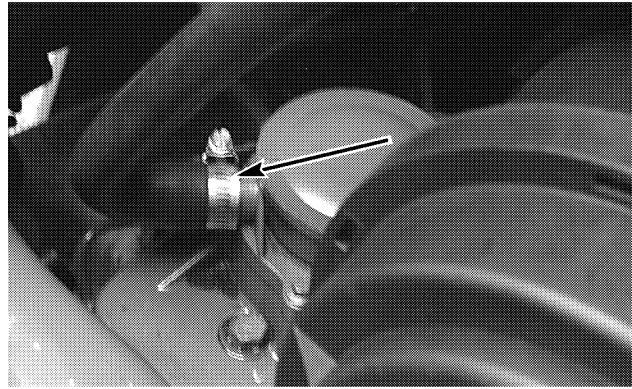

BS03K011

Disconnect crank case ventilation hose.

STEP 10

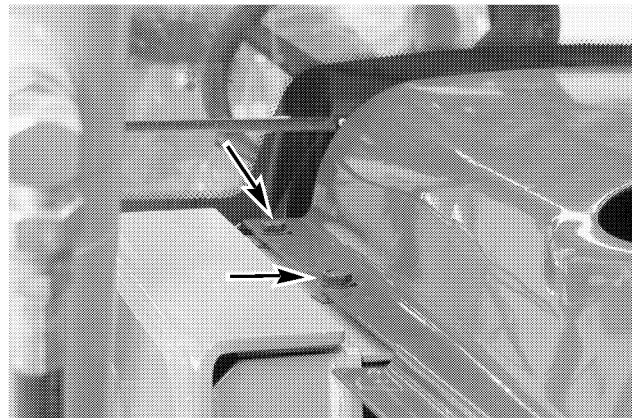

BD01B307

Remove the cap screws and flat washers that fasten the fixed hood to the uprights. Remove the fixed hood and air cleaner as an assembly.

STEP 11

Remove muffler and brackets from engine.

STEP 12

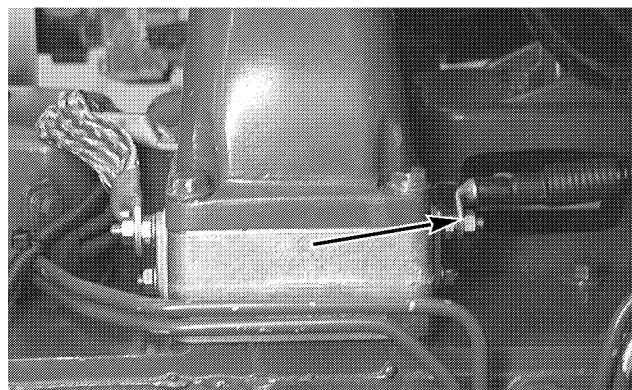

BS03K003

If equipped, disconnect grid heater positive cable and sensor wires.

STEP 13

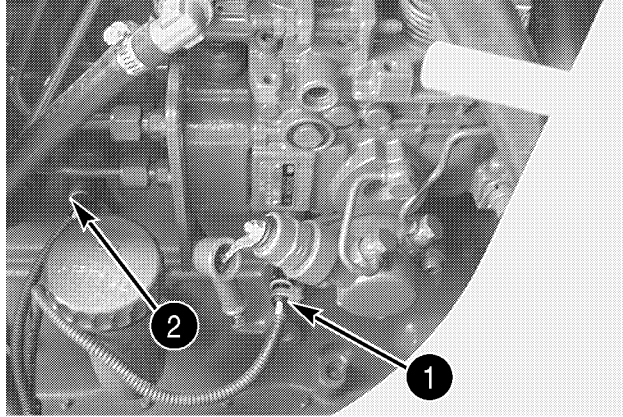

BS03K009

Disconnect the electrical connector for the fuel injection pump(1) and oil pressure sender (2).

STEP 14

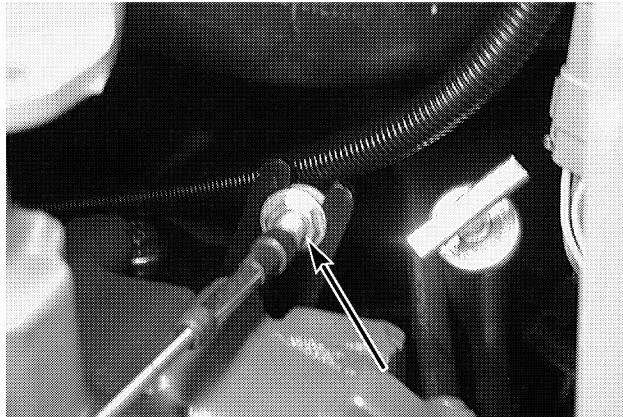

BS03K001

Disconnect the throttle cable from the mounting bracket.

STEP 15

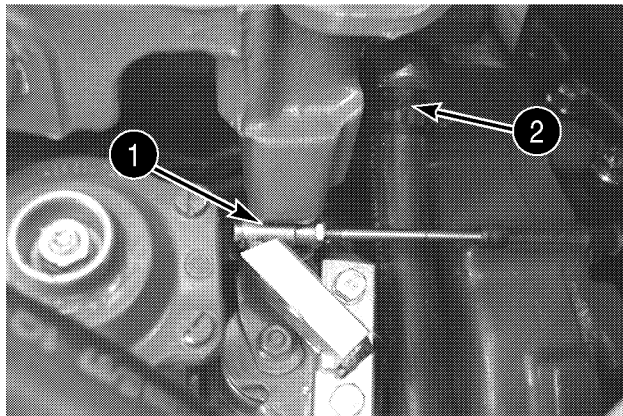

BS03K002

Disconnect the throttle rod (1). If equipped, disconnect the heater hose (2).

STEP 16

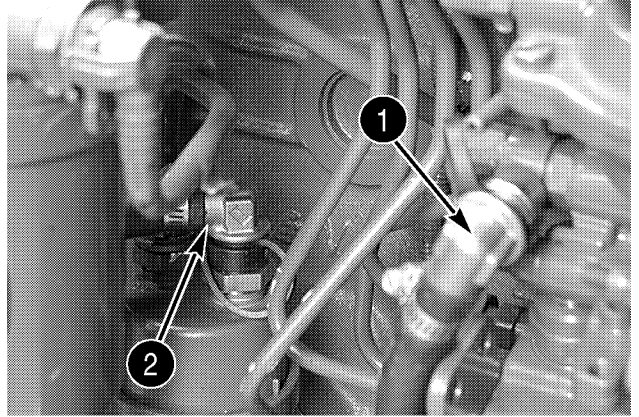

BS03K010

Disconnect the fuel return line (1) and the fuel input line (2).

STEP 17

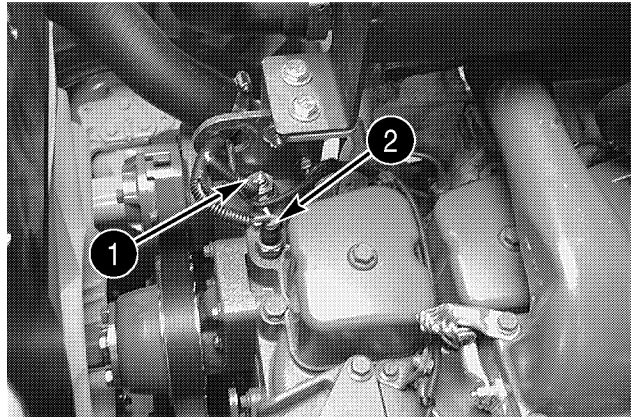

BS03K006

Disconnect the coolant temperature sender (1) and coolant temperature switch (2).

STEP 18

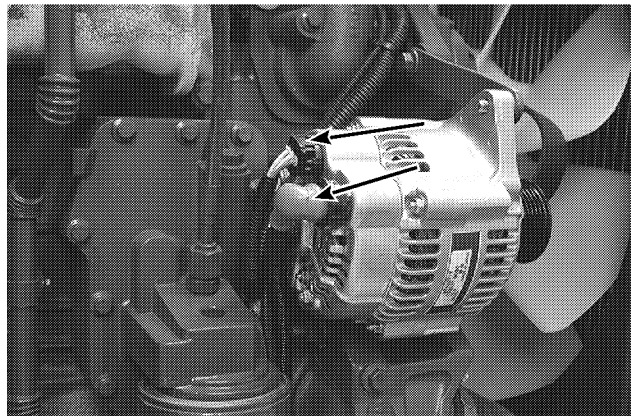

BS03K004

Disconnect the wires from the alternator.

STEP 19

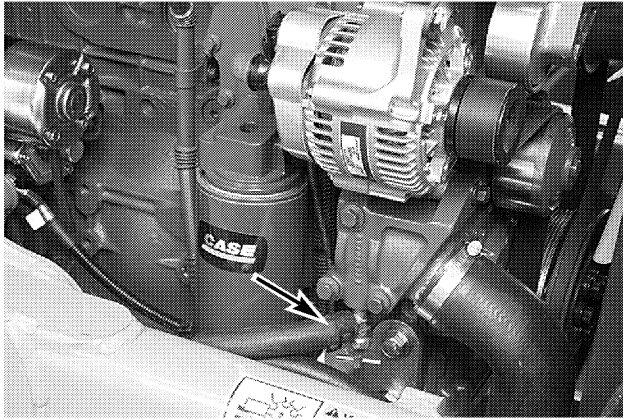

BS03K014

Disconnect the heater hose, if equipped.

STEP 20

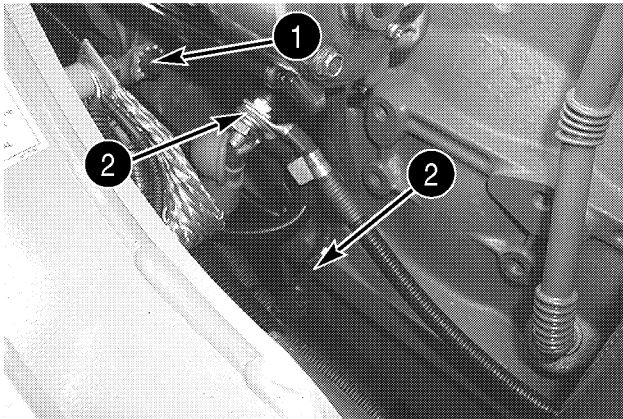

BS03K005

Disconnect the ground strap (1). Disconnect the wires (2) from the starter.

STEP 21



BD03K031

Remove the starter from the engine. Remove the plastic plug and access cover from the bell housing.

STEP 22

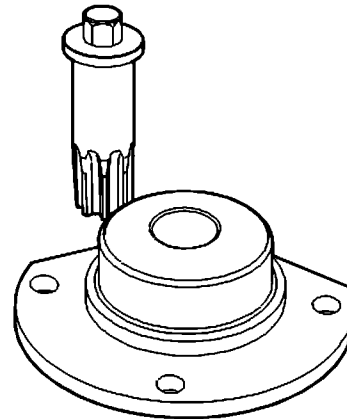

BC04A195

Install the engine turning tool to turn the flywheel for access to the cap screws.

STEP 23

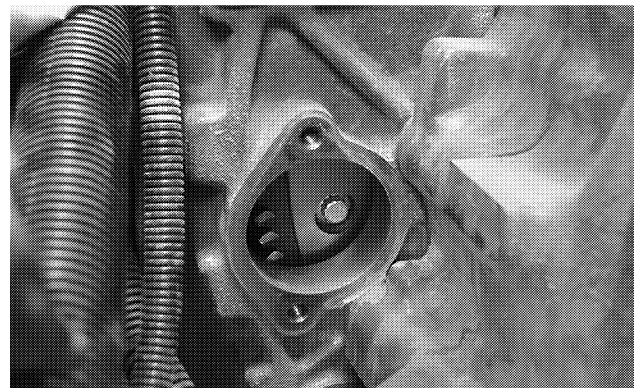

BD03K033

For machines equipped with either a standard or powershift transmission, loosen and remove four cap screws that fasten the flywheel to the flex plate.

NOTE: During installation tighten the cap screws to 52 to 57 Nm (38 to 42 lb-ft) for the standard transmission or the powershift transmission.

STEP 24

Connect lifting equipment to the lifting eyes on the engine to hold the engine in place.

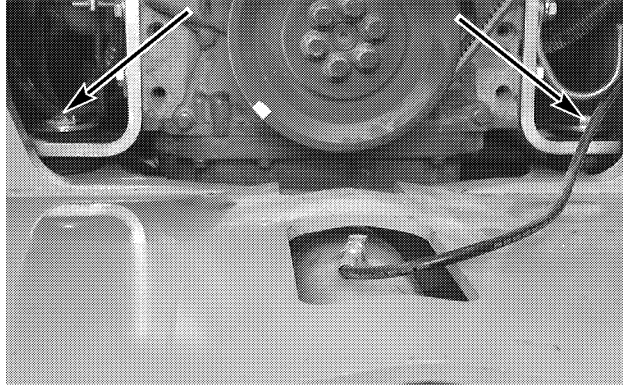
STEP 25

Remove the bolts, flat washers, and nuts from the front engine mount.

NOTE: During installation, tighten the self-locking nuts to 90 to 100 Nm (67 to 73 lb-ft).

STEP 26

Loosen and remove the 12 cap screws and flat washers that fasten the transmission to the engine. Move the heater hose and clamps out of the way.

NOTE: During installation tighten the cap screws to 52 to 57 Nm (38 to 42 lb-ft).

STEP 27

Move the engine forward and raise the engine. Remove the engine from the machine.

IMPORTANT: For machines with a powershift transmission make sure that the flex plate/converter assembly stays in place on the transmission. If the engine will be separated from the transmission for an extended period of time fasten the flex plate/converter assembly in place on the transmission.

NOTE: Installation of the engine is the reverse of removal.

IMPORTANT: Before starting the engine do the following.

1. See section 1002 Fluids and Lubricants in this manual for the correct type and quantities needed to replace lost or drained fluids and lubricants before starting the engine.
2. The turbocharger must be filled with oil. Disconnect the wire from the fuel shutoff solenoid. Actuate the starter for 10 to 20 seconds to fill the turbocharger with oil. Connect the wire to the fuel shutoff solenoid.
3. The hydraulic pump **must** be filled with oil. Do the following procedure to fill the hydraulic pump with oil:
 - A. Fill the hydraulic reservoir. Make sure the oil level in the hydraulic reservoir is correct.
 - B. Remove the cap from the hydraulic reservoir.
 - C. Use a nozzle and shop air to pressurize the hydraulic reservoir. Wrap a shop cloth around the end of the hose at the nozzle.

NOTE: 34.5 kPa (5 psi) to 69.0 kPa (10 psi) is all that is required to move the oil. Pressure above 69.0 kPa (10 psi) can damage the hydraulic reservoir.

- D. Have another person start and run the engine at low idle while shop air is being applied to the hydraulic reservoir.

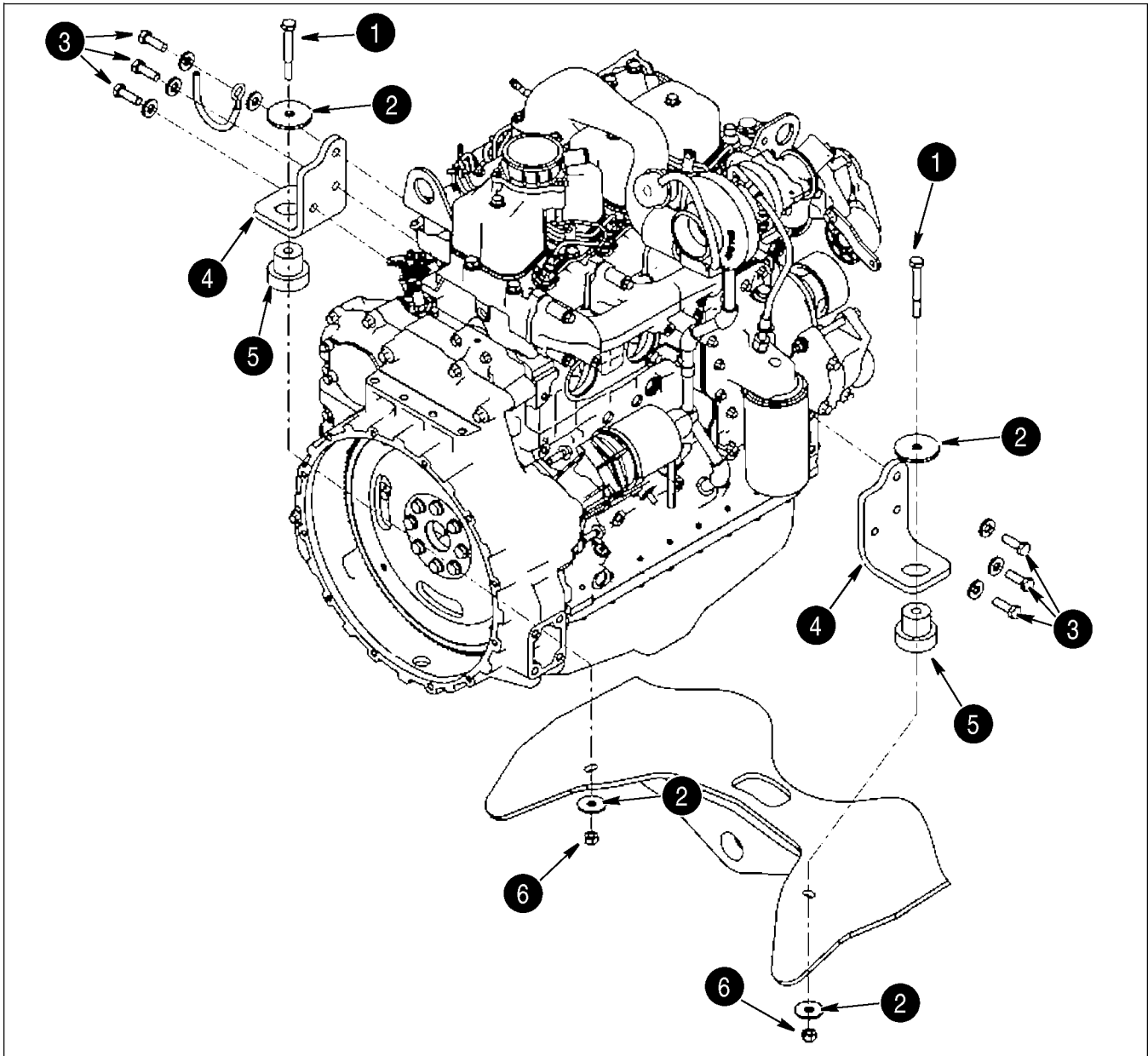

BC03K018

- 1. MOUNT BOLT
- 2. WASHER FLAT
- 3. BOLTS

- 4. MOUNTING BRACKET
- 5. RUBBER ENGINE MOUNT
- 6. LOCK NUT

ILLUSTRATION OF ENGINE MOUNTING

MUFFLER INSTALLATION

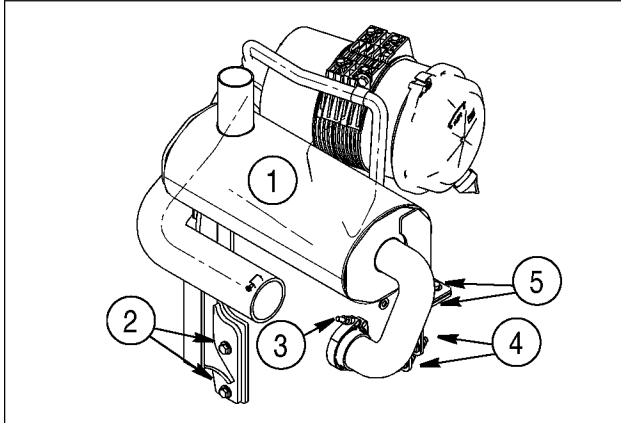

BC05F064

- | | |
|-------------------|--------------|
| 1. MUFFLER | 4. NUTS (6) |
| 2. BOLTS (2) | 5. BOLTS (5) |
| 3. CLAMP "T" BOLT | |

IMPORTANT: To prevent damage to the exhaust system do the following procedures in sequence.

1. Insert two flat washers per bolt (2) between bracket and engine block to prevent bracket from contacting engine block.
2. Assemble muffler (1) to engine with bolts finger tight.

NOTE: All gaps between mounting surfaces should be eliminated before torque sequence is started.

3. Align muffler flange with turbo (exhaust flange on natural aspirated engines) and tighten "T" bolt clamp (3) to 6.5 to 7.5 Nm (57.5 to 66.5 lb-in).
4. Tighten lower bolts (2) on rear bracket to engine block to a torque of 64 to 75 Nm (47 to 55 lb-ft).

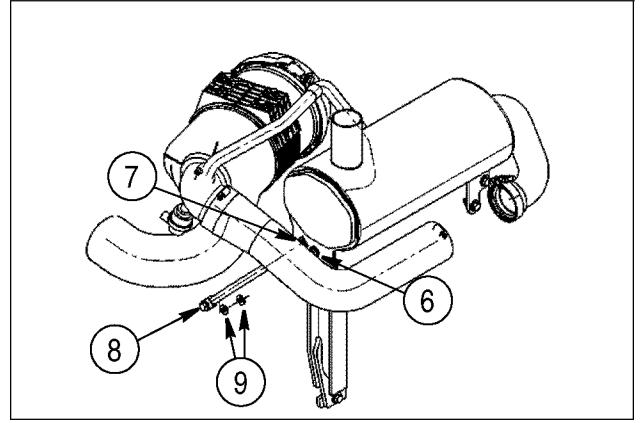

BC05F063

- | | |
|--------------------|---------------|
| 6. RIGHT HAND BOLT | 8. BRACE BOLT |
| 7. LEFT HAND BOLT | 9. WASHERS |
5. Tighten right hand bolt (6) to muffler to a torque of 64 to 75 Nm (47 to 55 lb-ft).
 6. Tighten mounting bolts (5) to front muffler bracket to a torque of 64 to 75 Nm (47 to 55 lb-ft).
 7. Tighten front bracket to engine lifting bracket mounting nuts (4) to a torque of 64 to 75 Nm (47 to 55 lb-ft).
 8. Insert washers (9), as required, to avoid interference with the brace and gear housing.
 9. Tighten brace mounting bolt (8) to gear housing to a torque of 64 to 75 Nm (47 to 55 lb-ft).
 10. Tighten rear brace left hand bolt (7) to muffler to a torque of 64 to 75 Nm (47 to 55 lb-ft).



Suggest:

If the above button click is invalid.

Please download this document

first, and then click the above link

to download the complete manual.

Thank you so much for reading

HOOD INSTALLATION

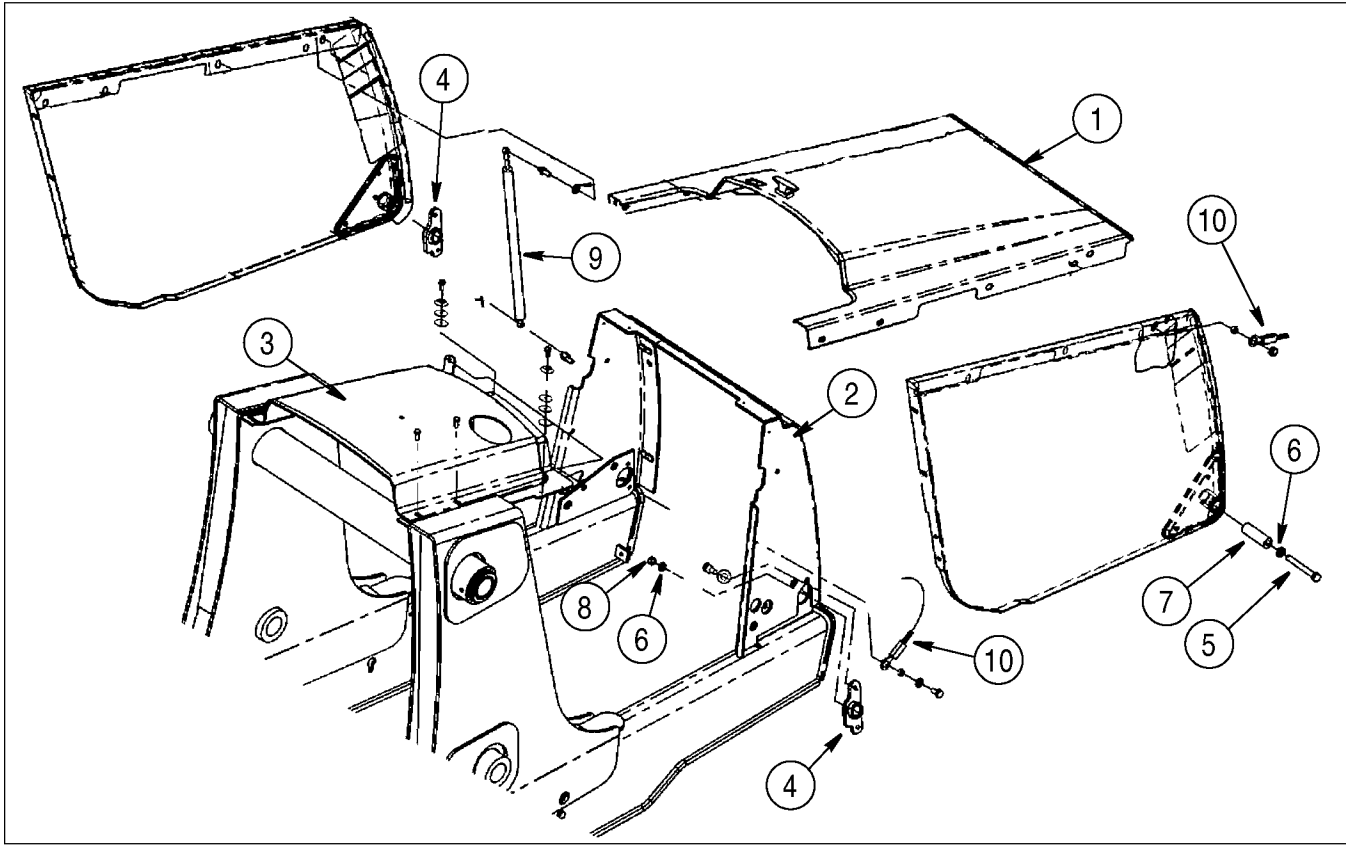

BC03K128

- | | |
|---------------------|---------------------------|
| 1. TILT HOOD | 6. FLAT WASHER |
| 2. RADIATOR WRAPPER | 7. PIVOT TUBE |
| 3. FIXED HOOD | 8. NUT |
| 4. PIVOT PLATE | 9. COUNTER BALANCE SPRING |
| 5. BOLT | 10. HOOD RETAINER CABLE |

NOTE: Hood is shown disassembled for clarity only.

1. Mount left and right pivot plates (4) onto frame finger tight.
2. Place tilt hood (1) onto radiator wrapper (2) and fixed hood (3).
3. Install pivot tube (7), bolt (5), washers (6), and nut (8), tighten nut.
4. Push tilt hood to the rear to minimize the gap between side panels and chassis uprights.
5. Tighten left and right pivot plates (4).
6. Raise tilt hood (1) just enough to attach the left and right counter balance springs (9) to ball studs, secure springs with retainer clips.
7. Attach hood retainer cable (10) to radiator wrapper.

<https://www.ebooklibonline.com>

Hello dear friend!

Thank you very much for reading.

Enter the link into your browser.

The full manual is available for immediate download.

<https://www.ebooklibonline.com>