

570N EP
Tier 4B (final)
Tractor Loader

SERVICE MANUAL

Part number 47821917
1st edition English
April 2015





SERVICE MANUAL

570N EP Four-Wheel Drive (4WD) TIER 4B (FINAL)
570N EP Two-Wheel Drive (2WD) TIER 4B (FINAL)

Link Product / Engine

Product	Market Product	Engine
570N EP Four-Wheel Drive (4WD) TIER 4B (FINAL)	North America	F5HFL463D*F005
570N EP Two-Wheel Drive (2WD) TIER 4B (FINAL)	North America	F5HFL463D*F005

<https://www.ebooklibonline.com>

Hello dear friend!

Thank you very much for reading.

Enter the link into your browser.

The full manual is available for immediate download.

<https://www.ebooklibonline.com>

Contents

INTRODUCTION

Engine	10
[10.001] Engine and crankcase	10.1
[10.216] Fuel tanks	10.2
[10.501] Exhaust Gas Recirculation (EGR) - Diesel Particulate Filter (DPF) exhaust treatment	10.3
[10.400] Engine cooling system	10.4
[10.414] Fan and drive	10.5
Transmission	21
[21.112] Power shuttle transmission.....	21.1
[21.134] Power shuttle transmission external controls	21.2
[21.154] Power shuttle transmission internal components	21.3
Front axle system	25
[25.100] Powered front axle	25.1
[25.102] Front bevel gear set and differential	25.2
[25.108] Final drive hub, steering knuckles, and shafts	25.3
[25.400] Non-powered front axle	25.4
Rear axle system	27
[27.100] Powered rear axle.....	27.1
[27.106] Rear bevel gear set and differential	27.2
[27.120] Planetary and final drives	27.3
Power Take-Off (PTO)	31
[31.104] Rear electro-hydraulic control.....	31.1
Hydraulic systems	35
[35.000] Hydraulic systems.....	35.1
[35.300] Reservoir, cooler, and filters.....	35.2

[35.104] Fixed displacement pump	35.3
[35.102] Pump control valves.....	35.4
[35.350] Safety and main relief valves	35.5
[35.204] Remote control valves	35.6
[35.114] Three-point hitch control valve	35.7
[35.116] Three-point hitch cylinder	35.8
[35.723] Front loader bucket hydraulic system	35.9
[35.734] Tool quick coupler hydraulic system	35.10
Wheels	44
[44.511] Front wheels.....	44.1
[44.520] Rear wheels.....	44.2
Cab climate control	50
[50.200] Air conditioning.....	50.1
Electrical systems	55
[55.100] Harnesses and connectors.....	55.1
[55.525] Cab engine controls.....	55.2
[55.991] Telematics	55.3
[55.DTC] FAULT CODES.....	55.4
Front loader and bucket.....	82
[82.100] Arm.....	82.1
[82.300] Bucket.....	82.2
Platform, cab, bodywork, and decals	90
[90.150] Cab.....	90.1
[90.114] Operator protections	90.2
[90.105] Machine shields and guards	90.3



INTRODUCTION

Safety rules

▲ DANGER

Improper operation or service of this machine can result in an accident.
Do not operate this machine or perform any lubrication, maintenance, or repair on it until you have read and understood the operation, lubrication, maintenance, and repair information.
Failure to comply will result in death or serious injury.

D0010A

▲ WARNING

Maintenance hazard!
Always perform all service procedures punctually at the intervals stated in this manual. This ensures optimum performance levels and maximum safety during machine operation.
Failure to comply could result in death or serious injury.

W0132A

▲ WARNING

Pressurized system!
Before attempting any service procedure, it is your responsibility to know the number of accumulators on the machine, and the correct procedure for releasing the pressure of each accumulator.
Failure to comply could result in death or serious injury.

W0136A

NOTICE: *Extreme working and environmental conditions require shortened service intervals.*

Use Case fluids, lubricants, and filters for the best protection and performance of your machine. All fluids, lubricants, and filters must be disposed of in compliance with environmental standards and regulations. Contact your dealer with any questions regarding the service and maintenance of this machine.

Read the safety decals and information decals on the machine. Read the Operator's Manual and safety manual. Understand the operation of the machine before you start any service.

Before you service the machine, put a 'Do Not Operate' tag on the steering wheel or over the key switch. Ensure the tag is at a location where everyone who might operate or service the machine may see clearly. One tag is included with your new machine. Additional tags are available from your dealer.

Plastic and resin parts

- Avoid using gasoline, paint thinner, etc. when cleaning plastic parts, console, instrument cluster, etc.
- Use only water, mild soap, and a soft cloth when you clean these parts.
- Using gasoline, thinners, etc. can cause discoloration, cracking, or deformation of the part being cleaned.

Safety rules Ductile iron



⚠ DANGER

Improper operation or service of this machine can result in an accident. Any unauthorized modifications made to this machine can have serious consequences. Consult an authorized dealer on changes, additions, or modifications that may be required for this machine. Do not make any unauthorized modifications. Failure to comply will result in death or serious injury.

D0030A

Before you weld, cut, or drill holes on any part of this machine, make sure the part is not cast ductile iron. See your dealer if you do not know if a part is cast ductile iron. The following are cast ductile iron parts:

- two wheel drive steering link
- dump links
- front axle
- Air Conditioning (A/C) compressor mounting bracket

Unauthorized modifications to cast ductile iron parts can cause injury or death. Welding, cutting, or drilling can cause cast ductile iron to break. Do not weld, cut, or drill to repair or to attach items to cast ductile iron parts on this machine.

Safety rules

Personal safety





This is the safety alert symbol. It is used to alert you to potential personal injury hazards. Obey all safety messages that follow this symbol to avoid possible death or injury.

Throughout this manual you will find the signal words DANGER, WARNING, and CAUTION followed by special instructions. These precautions are intended for the personal safety of you and those working with you.

Read and understand all the safety messages in this manual before you operate or service the machine.

 DANGER indicates a hazardous situation that, if not avoided, will result in death or serious injury.

 WARNING indicates a hazardous situation that, if not avoided, could result in death or serious injury.

 CAUTION indicates a hazardous situation that, if not avoided, could result in minor or moderate injury.

FAILURE TO FOLLOW DANGER, WARNING, AND CAUTION MESSAGES COULD RESULT IN DEATH OR SERIOUS INJURY.

Machine safety

NOTICE: Notice indicates a situation that, if not avoided, could result in machine or property damage.

Throughout this manual you will find the signal word Notice followed by special instructions to prevent machine or property damage. The word Notice is used to address practices not related to personal safety.

Information

NOTE: Note indicates additional information that clarifies steps, procedures, or other information in this manual.

Throughout this manual you will find the word Note followed by additional information about a step, procedure, or other information in the manual. The word Note is not intended to address personal safety or property damage.

Safety rules - Ecology and the environment

Soil, air, and water quality is important for all industries and life in general. When legislation does not yet rule the treatment of some of the substances that advanced technology requires, sound judgment should govern the use and disposal of products of a chemical and petrochemical nature.

Familiarize yourself with the relative legislation applicable to your country, and make sure that you understand this legislation. Where no legislation exists, obtain information from suppliers of oils, filters, batteries, fuels, anti-freeze, cleaning agents, etc., with regard to the effect of these substances on man and nature and how to safely store, use, and dispose of these substances.

Helpful hints

- Avoid the use of cans or other inappropriate pressurized fuel delivery systems to fill tanks. Such delivery systems may cause considerable spillage.
- In general, avoid skin contact with all fuels, oils, acids, solvents, etc. Most of these products contain substances that may be harmful to your health.
- Modern oils contain additives. Do not burn contaminated fuels and or waste oils in ordinary heating systems.
- Avoid spillage when you drain fluids such as used engine coolant mixtures, engine oil, hydraulic fluid, brake fluid, etc. Do not mix drained brake fluids or fuels with lubricants. Store all drained fluids safely until you can dispose of the fluids in a proper way that complies with all local legislation and available resources.
- Do not allow coolant mixtures to get into the soil. Collect and dispose of coolant mixtures properly.
- The air-conditioning system contains gases that should not be released into the atmosphere. Consult an air-conditioning specialist or use a special extractor to recharge the system properly.
- Repair any leaks or defects in the engine cooling system or hydraulic system immediately.
- Do not increase the pressure in a pressurized circuit as this may lead to a component failure.
- Protect hoses during welding. Penetrating weld splatter may burn a hole or weaken hoses, allowing the loss of oils, coolant, etc.

Battery recycling

Batteries and electric accumulators contain several substances that can have a harmful effect on the environment if the batteries are not properly recycled after use. Improper disposal of batteries can contaminate the soil, groundwater, and waterways. CASE CONSTRUCTION strongly recommends that you return all used batteries to a CASE CONSTRUCTION dealer, who will dispose of the used batteries or recycle the used batteries properly. In some countries, this is a legal requirement.



Mandatory battery recycling

NOTE: The following requirements are mandatory in Brazil.

Batteries are made of lead plates and a sulfuric acid solution. Because batteries contain heavy metals such as lead, CONAMA Resolution 401/2008 requires you to return all used batteries to the battery dealer when you replace any batteries. Do not dispose of batteries in your household garbage.

Points of sale are obliged to:

- Accept the return of your used batteries
- Store the returned batteries in a suitable location
- Send the returned batteries to the battery manufacturer for recycling

Product identification – machine overview

Left-hand side of the machine

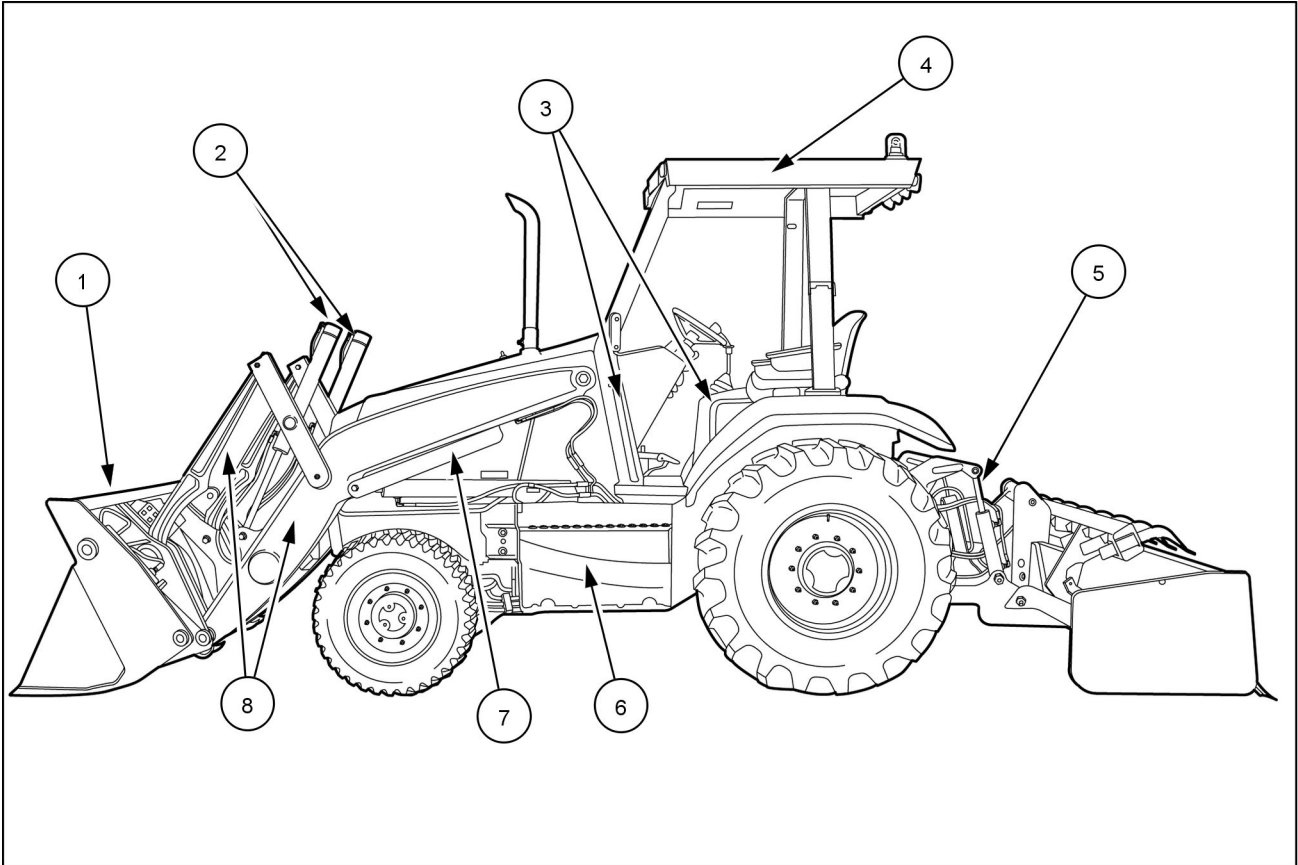

RAPH12UTL0116GA 1

1. Loader bucket
2. Bucket cylinders
3. Hand-holds
4. Canopy with optional beacon (cab not shown)
5. Three-point hitch with optional box grader
6. Fuel tank with entry step
7. Loader arm support strut
8. Loader arm and bucket linkage

Right-hand side of the machine

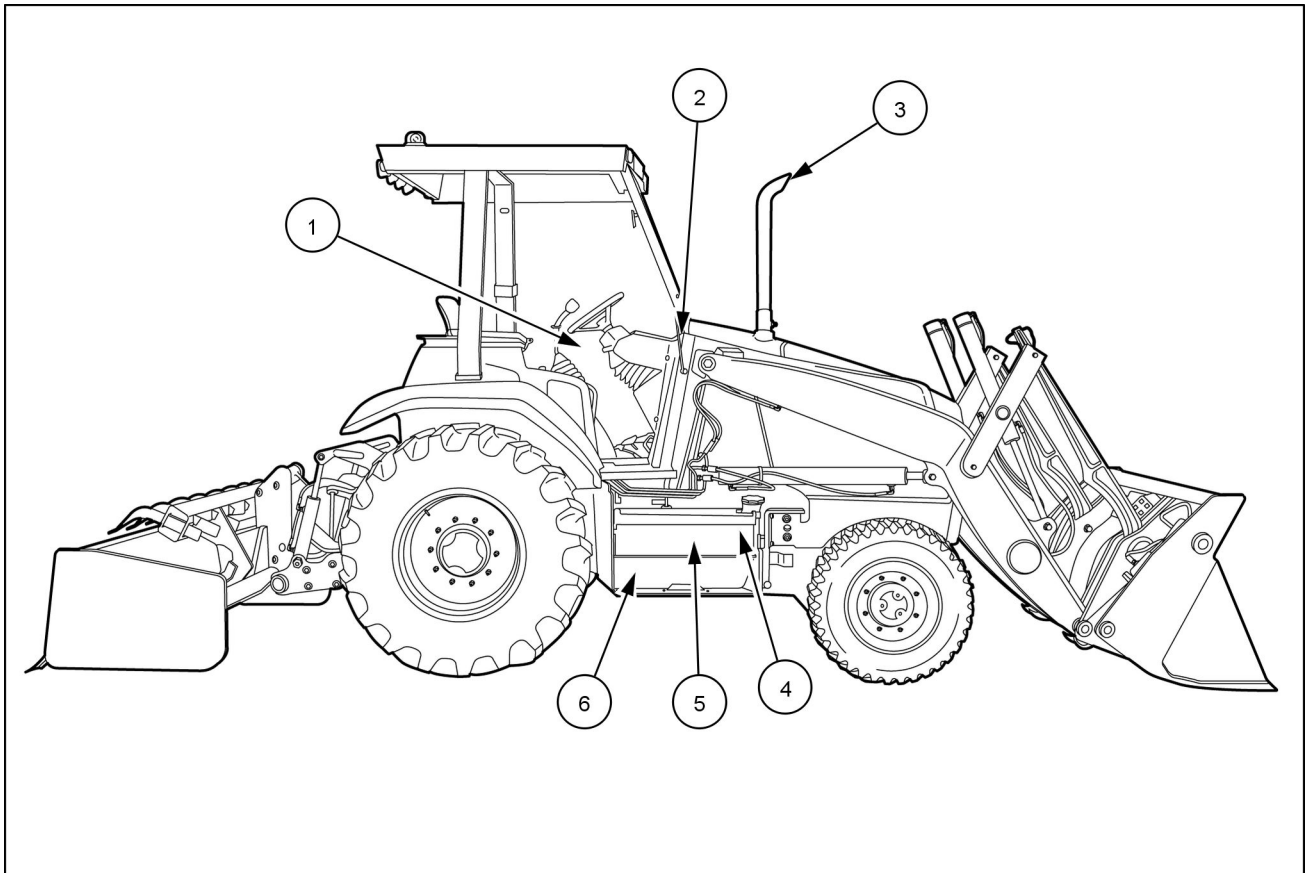

RAPH12UTL0113GA 2

1. Operator platform
2. Hand holds (only one on the right hand side)
3. Exhaust stack
4. Hydraulic tank
5. Tool box (optional equipment)
6. Battery compartment



SERVICE MANUAL

Engine

570N EP Four-Wheel Drive (4WD) TIER 4B (FINAL)
570N EP Two-Wheel Drive (2WD) TIER 4B (FINAL)

Engine - General specification

Model	Diesel, F5HFL463D*F005, Tier 4B (Final) emissions compliant
Type	Four cylinder, turbocharged
Firing order	1-3-4-2
Bore and stroke	99 mm x 110 mm (3.90 in x 4.33 in)
Displacement	3.4 L (207.5 in³)
Compression ratio	17 to 1
Fuel injection	Direct High Pressure Common Rail (HPCR)
Horsepower - rated at 2200 RPM	
Gross	55 kW (75 Hp)
Net with 33° fan	51 kW (69 Hp)
Net with viscous fan	53.5 kW (72.7 Hp)
Peak torque at 1400 RPM	
Gross	316 N·m (233 lb ft)
Net with 33° fan	298 N·m (220 lb ft)
Net with viscous fan	310 N·m (229 lb ft)
Maximum torque rise	35% ± 5 RPM
Engine speeds – standard powertrain configuration	
Rated speed, full load	2200 RPM
Low idle	900 - 1000 RPM
High idle, no load	2330 - 2430 RPM
Converter stall	2025 - 2200 RPM
Loader stall	2150 - 2300 RPM
Combined stall	1450 - 1720 RPM
Engine speeds – PTO or PTO ready powertrain configuration	
Rated speed, full load	2200 RPM
Low idle	900 - 1000 RPM
High idle, no load	2330 - 2430 RPM
Converter stall	1925 - 2075 RPM
Loader stall	2150 - 2300 RPM
Combined stall	1375 - 1625 RPM

Engine - Engine and crankcase

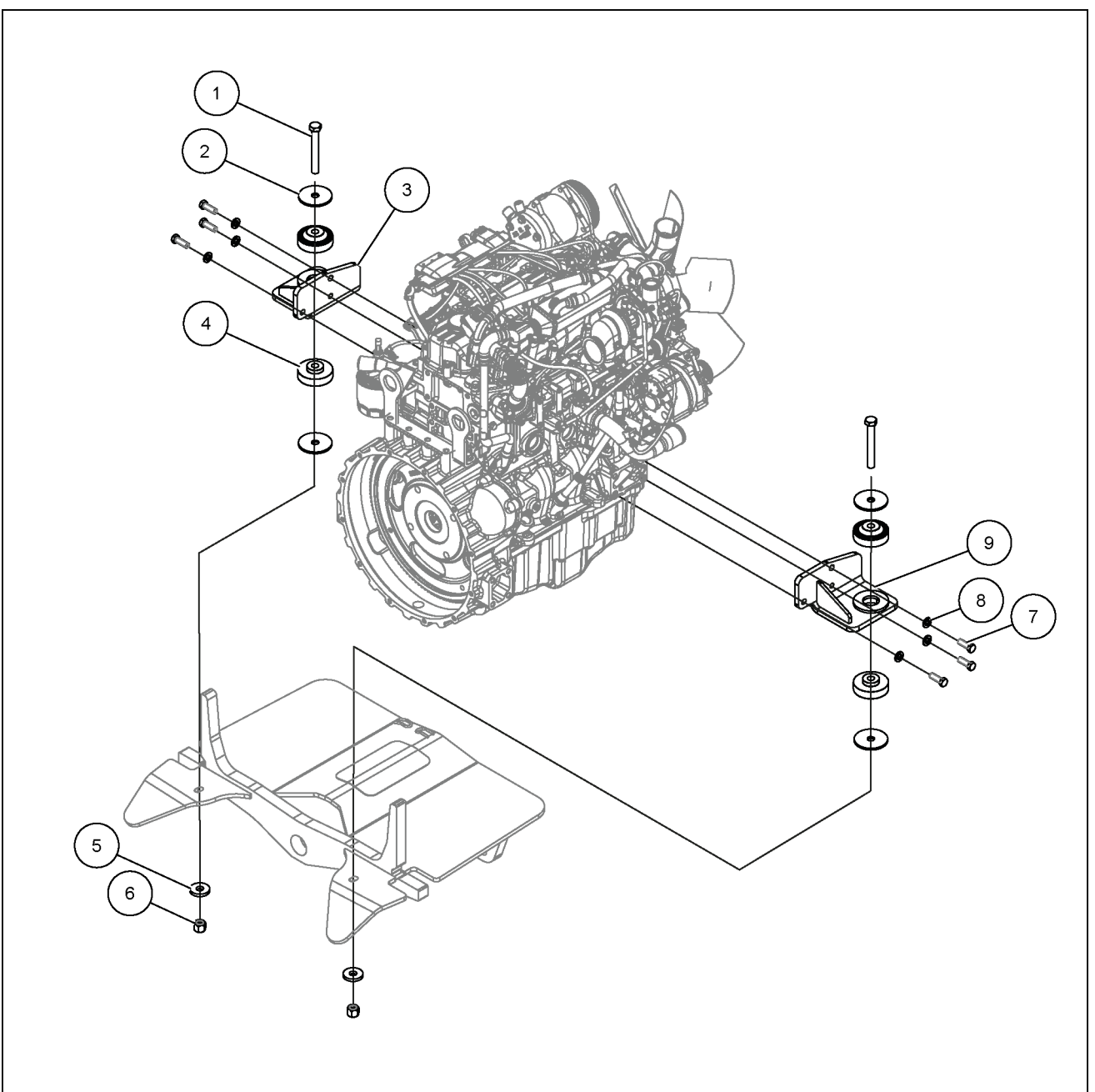

RAIL12UTL0338GA 1

Engine - Drain fluid

1. Start the engine and run until the engine is warm. A warm engine allows a more complete removal of foreign material.
2. Park on level ground, raise the loader arms, engage the safety support strut, and shut down the engine.
3. Clean the areas around the:
 - Engine fill cap **(1)**
 - Engine oil filter and head **(2)** (located underneath the fixed hood)
 - Engine oil dipstick **(3)**
 - Oil pan drain plug (not shown)

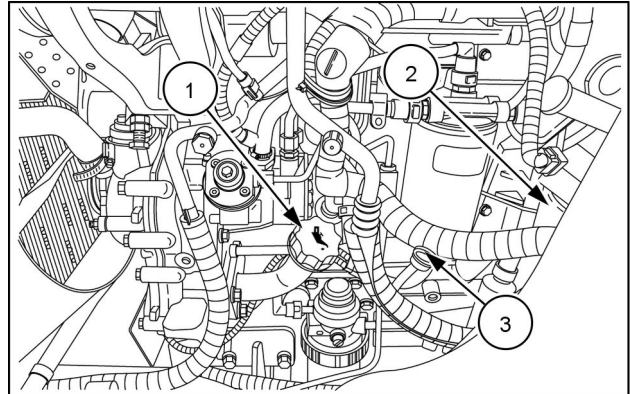

RAIL11TLB0008AA 1

4. Slowly open the drain plug for the engine oil pan and drain the oil into a suitable container.

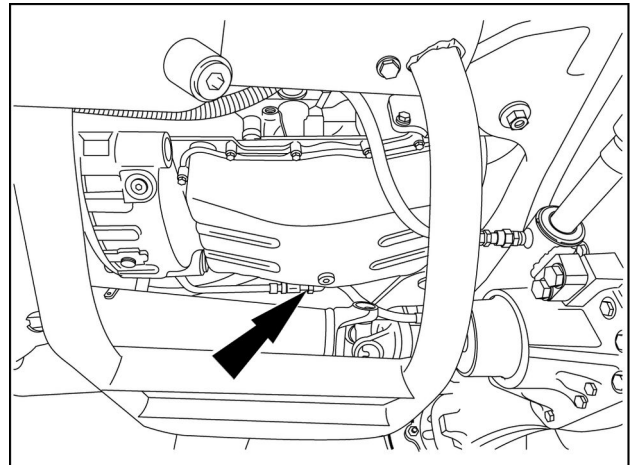

RCPH11TLB016AAD 2

5. Install the drain plug for the engine oil tank.

Engine - Filling

Engine oil specifications: **8.0 L (8.5 US qt)** of **CASE AKCELA UNITEK NO. 1™ SBL CJ-4 SAE 10W-40**. For machines operating in cold regions, see “Engine oil viscosity - Recommended engine oil for operating temperature ranges” **Engine lubrication system - General specification (10.304)**.

1. Clean the areas around the:

- Engine fill cap **(1)**
- Engine oil filter and head **(2)** (located underneath the fixed hood)
- Engine oil dipstick **(3)**
- Oil pan drain plug (not shown)

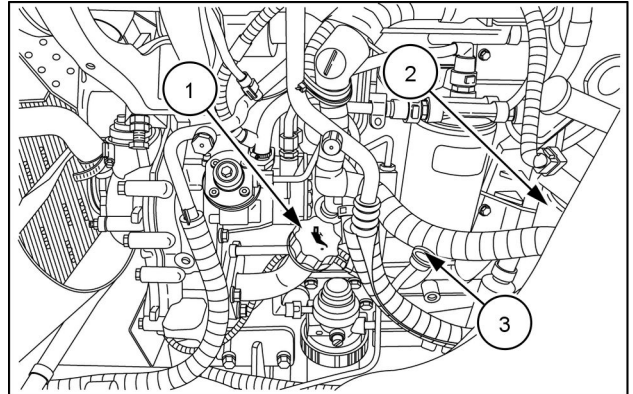

RAIL11TLB0008AA 1

2. Make sure that the oil drain plug is installed.

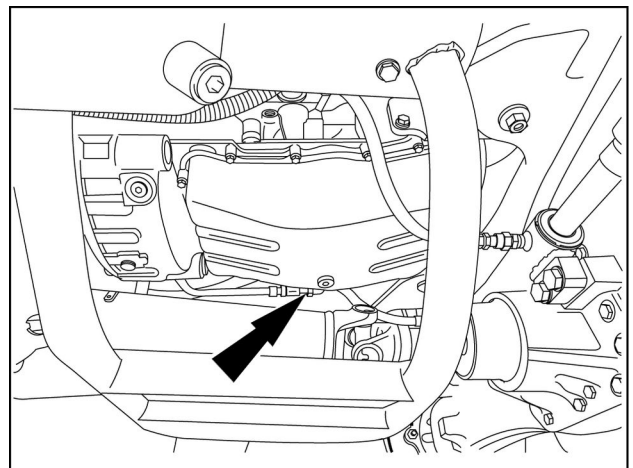

RCPH11TLB016AAD 2

3. Put new oil into the engine.

4. If applicable, clear the Oil life reset active warning symbol for the display screen. See “Oil life reset” **Engine oil system - Program (55.013)**.

Engine - Remove

Prior operation:

Remove the engine hood. See **Engine hood - Remove (90.105)**.

Prior operation:

Remove the Particulate Matter Catalyst tray. See **Diesel Oxidation Catalyst (DOC) - Remove (10.501)**

Prior operation:

Drain the engine cooling system. See **Radiator - Drain fluid (10.400)**.

Prior operation:

Remove the engine cooling system. See **Radiator - Remove (10.400)**.

Prior operation:

If equipped, evacuate the air-conditioning system. See **Air conditioning - Charging Air conditioner system evacuation and recharging (50.200)**

1. If equipped, disconnect the A/C high pressure line (1).
2. If equipped, disconnect electrical connectors (2) and (3).
3. If equipped, disconnect the A/C low pressure line (4).
4. If equipped, disconnect the A/C condenser voltage wire (5).

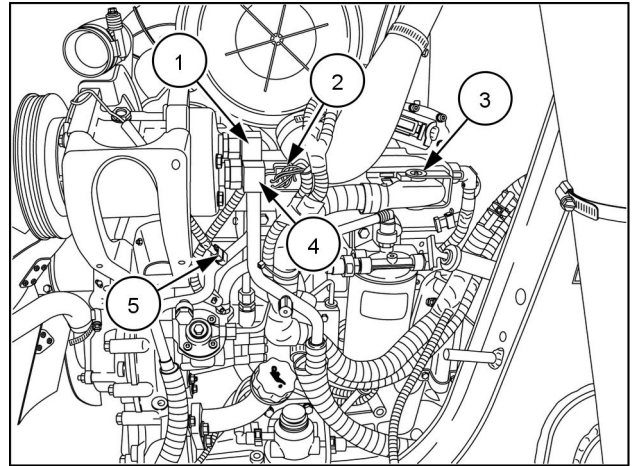

RAPH11TLB0045BA 1

5. Disconnect fuel lines (1) and (2).

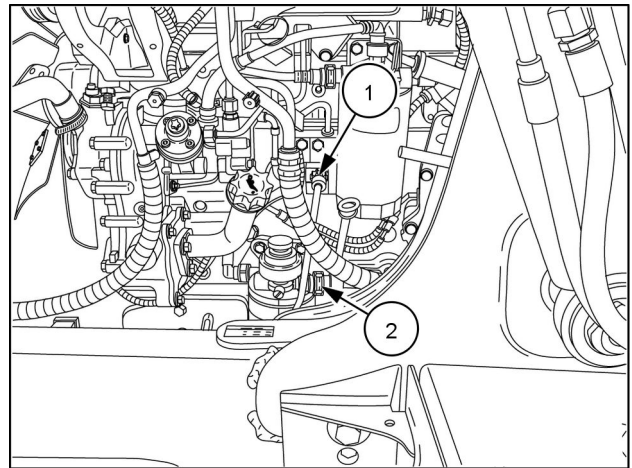

RAPH11TLB0041BA 2

6. Disconnect the water sensor electrical connector (not shown).

NOTE: Water sensor is located at the bottom of the primary fuel filter.

7. Disconnect the glow plug control unit electrical connector (1).

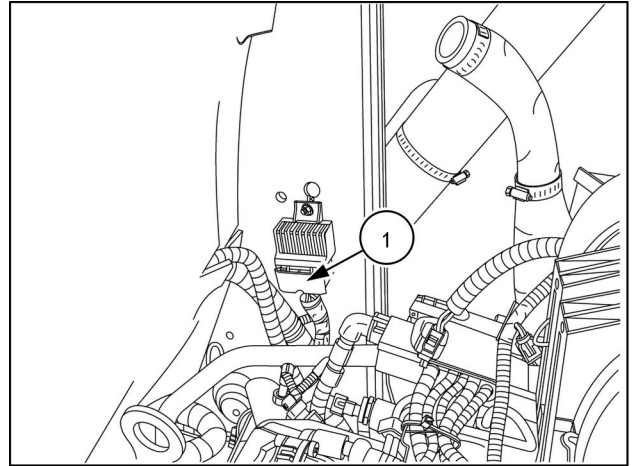

RAPH11TLB0021BA 3

8. Remove the supporting bracket (1) and hanging barrier curtain (2).

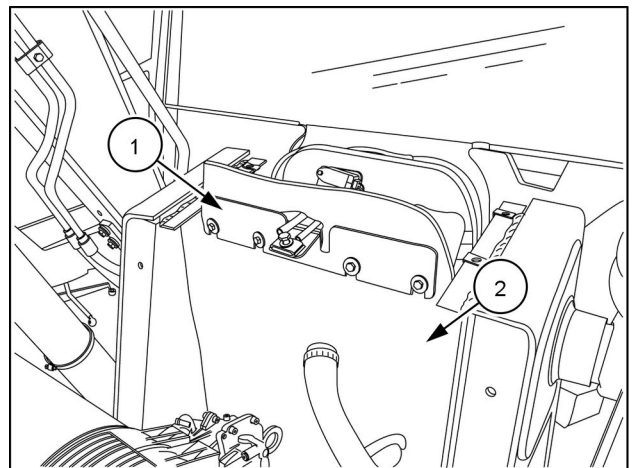

RAPH11TLB0040BA 4

9. Disconnect the heater hose (1).

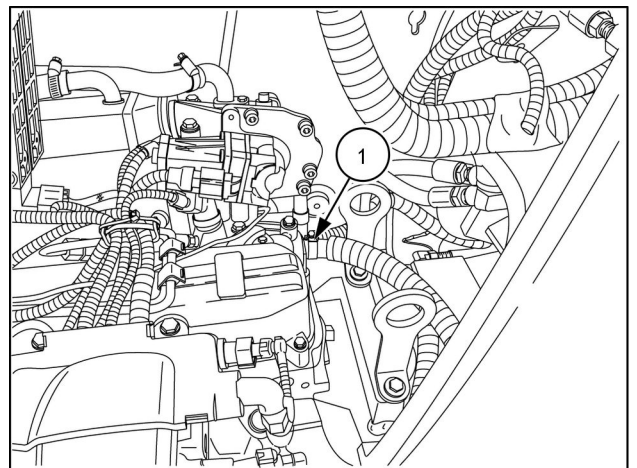

RAPH11TLB0039BA 5

10. Disconnect the air temperature sensor.

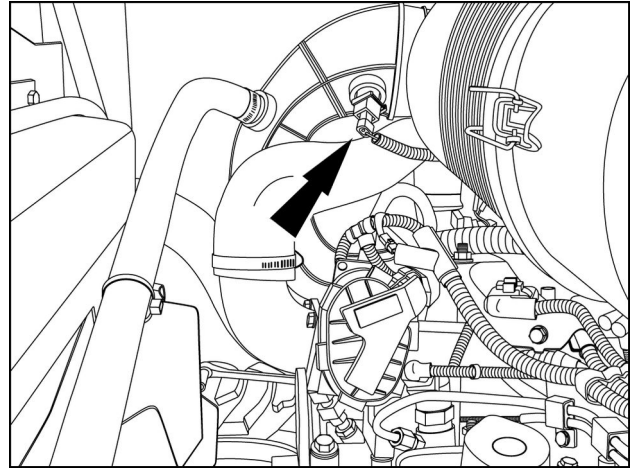

RAIL14FRK0115BA 6

11. Remove the air intake hose clamp.

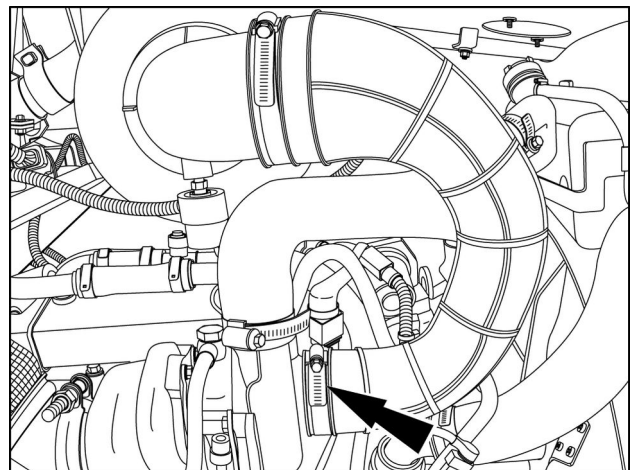

RAIL14FRK0104BA 7

NOTE: For assembly purposes, identify and label all electrical connectors.

12. Disconnect the wires from the air restriction indication switch.
13. Remove the air filter assembly and cap all openings.

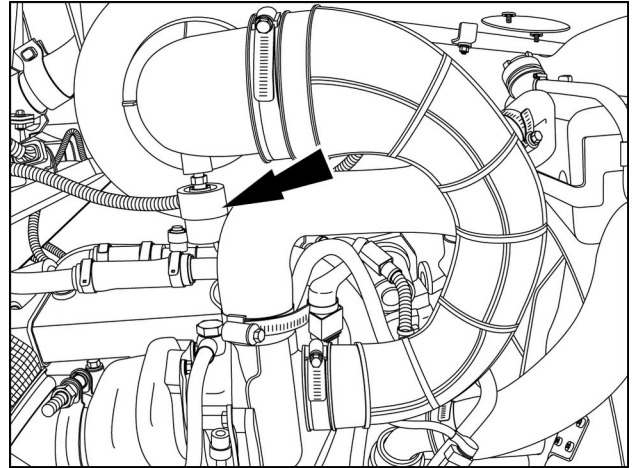

RAIL14FRK0104BA 8

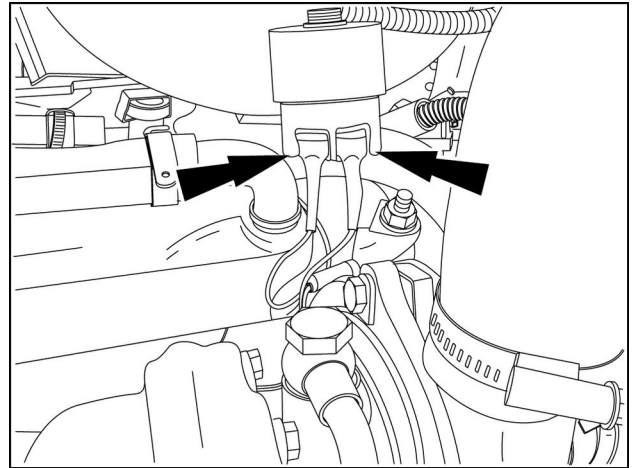

RAIL14FRK0122BA 9

14. Disconnect the wiring harness connector (1) and the positive battery cable (2) from the rear of the alternator.

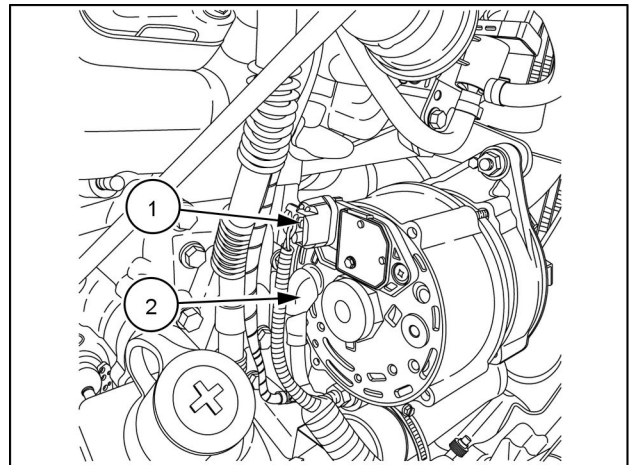

RAPH12FRK0163AA 10

15. If equipped, remove the battery disconnect switch bracket from the frame and set aside.

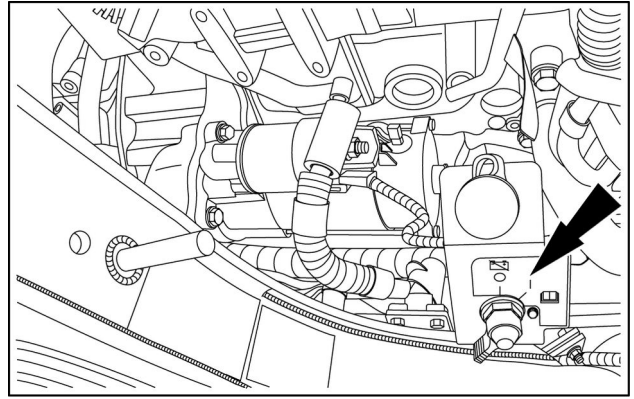

RAIL14TLB0403AA 11

16. Remove the nut (3), disconnect the wire harness (4) and positive battery cable (2) from the terminal on the starter (1).

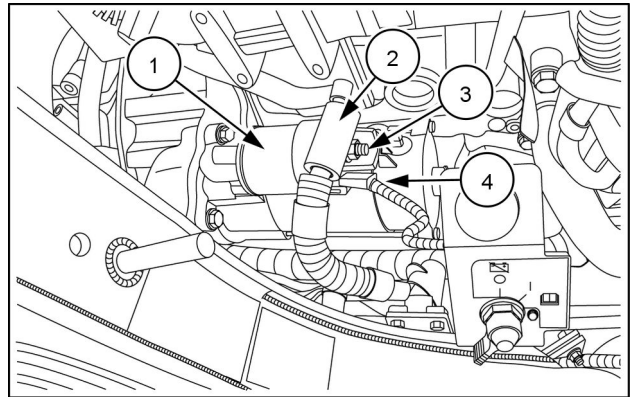

RAIL14TLB0403AA 12

17. Disconnect the ground strap.

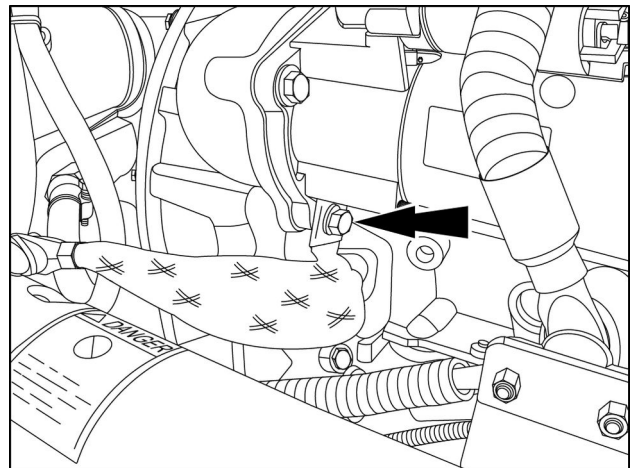

RAIL14FRK0129BA 13

18. On the right-hand side of the engine remove both caps to access the flex plate bolts.

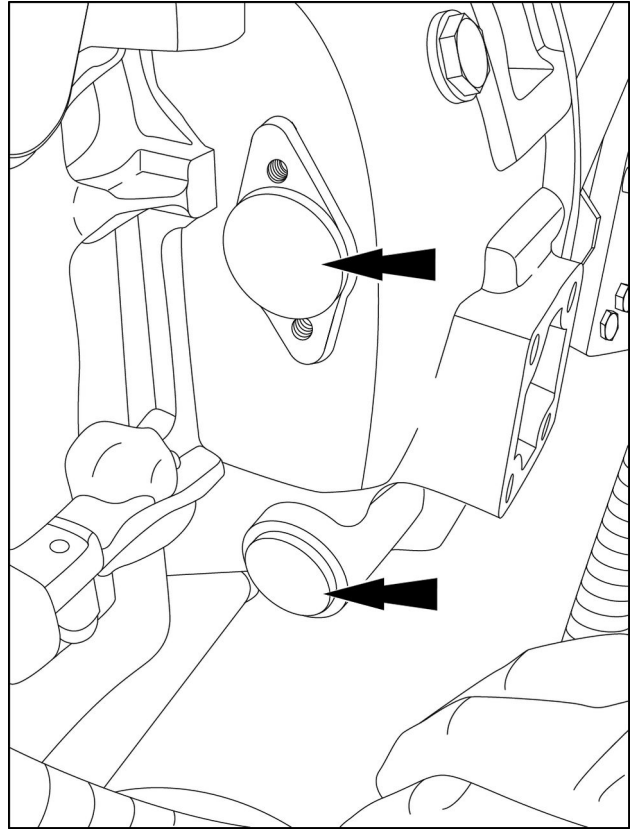

RAIL14FRK0141BA 14

19. Insert the engine turning tool **380000988** into the lower opening and rotate the flywheel until the flex plate bolt is visible in the top opening.

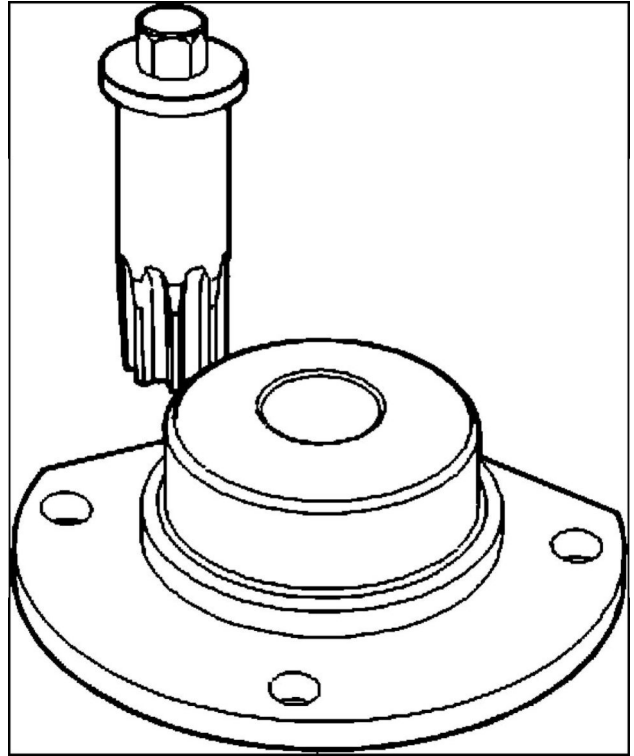

RAPH12FRK0979BA 15

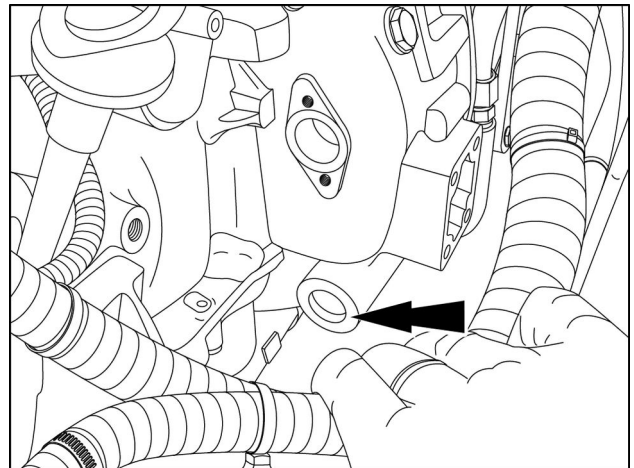

RAIL14FRK0139BA 16

20. Remove all the bolts that fasten the flywheel to the flex plate.

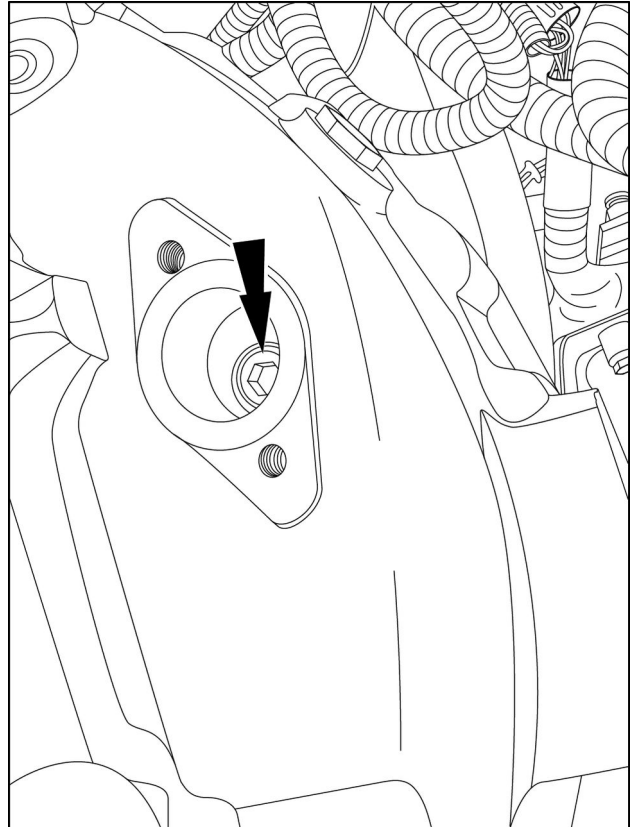

RAIL14FRK0140BA 17

21. Support the engine using safe, lifting equipment.

⚠ DANGER

Heavy parts!
Support designated component(s) with adequate lifting equipment.
Failure to comply will result in death or serious injury.

D0018A

Specification

Engine weight (approximate)	363 kg (800 lb)
-----------------------------	------------------------

22. Remove all the bolts and washers that fasten the transmission to the flywheel housing (two shown).

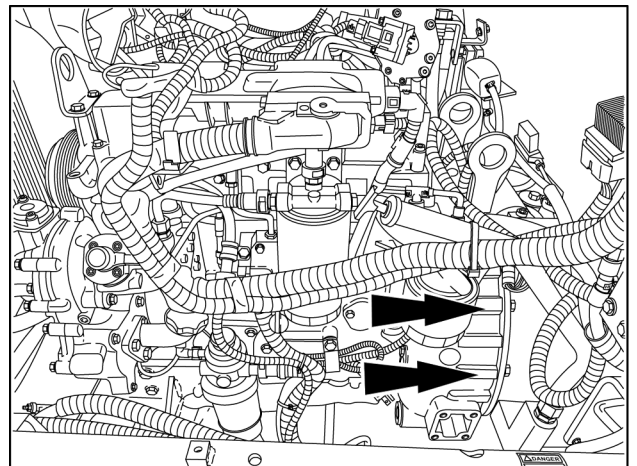

RAPH12FRK0977BA 18

23. Loosen the motor mount-to-frame bolts on both sides of the engine.
24. Remove all motor mount-to-engine bolts on both sides of the engine.

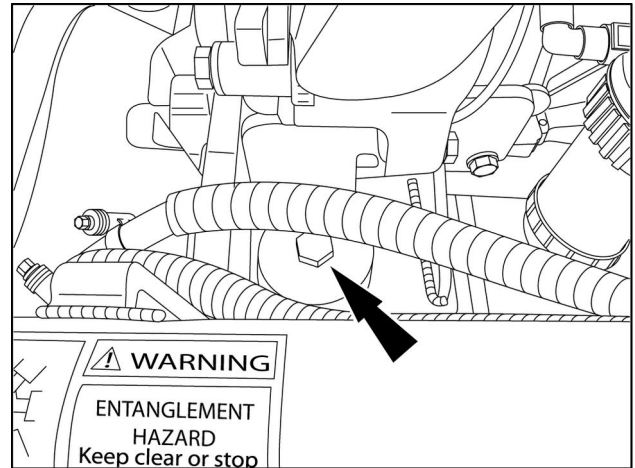

RAPH12FRK0103BA 19

NOTICE: Avoid machine damage. Maintain adequate clearance between the engine and machine frame. Make sure the engine components **DO NOT** come in contact or hang up on the frame or frame components during engine removal.

25. Carefully raise and remove the engine from the machine.
26. Place the engine on the repair stand and repair or replace as necessary.

Engine - Install

⚠ DANGER

Heavy objects!

Lift and handle all heavy components using lifting equipment with adequate capacity. Always support units or parts with suitable slings or hooks. Make sure the work area is clear of all bystanders.

Failure to comply will result in death or serious injury.

D0076A

Specification

Engine weight (approximate)	363 kg (800 lb)
-----------------------------	------------------------

1. Attach an appropriate lifting device to the three engine lift eyelets (1) on the engine as shown.

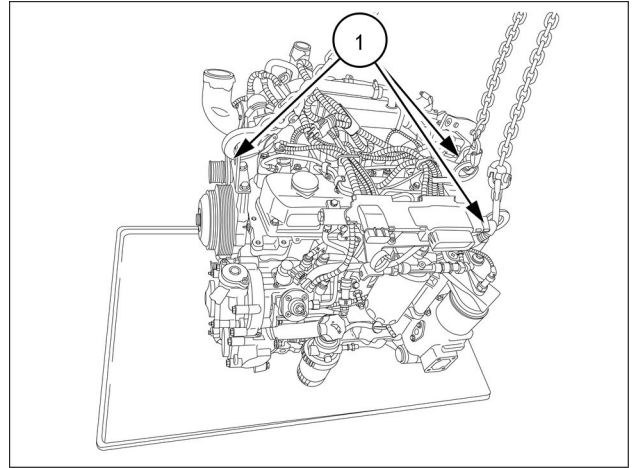

RAPH12FRK0643HA 1

NOTICE: Avoid machine damage. Maintain adequate clearance between the engine and machine frame. Make sure the engine components DO NOT come in contact or hang up on the frame or frame components during engine removal.

2. Carefully raise and position the engine in the machine.
3. Install all the bolts and washers that fasten the transmission to the flywheel housing (only two shown). Do not tighten at this time.

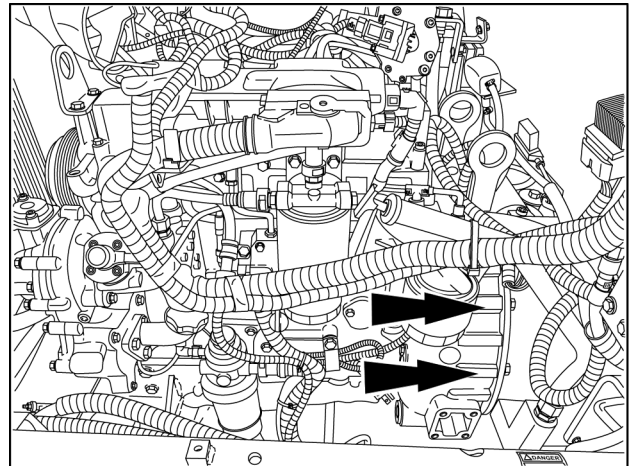

RAPH12FRK0977BA 2



Suggest:

If the above button click is invalid.

Please download this document

first, and then click the above link

to download the complete manual.

Thank you so much for reading

4. Install all motor mount-to-engine bolts on both sides of the engine. Tighten to specification.
5. Install the motor mount-to-frame bolts on both sides of the engine.

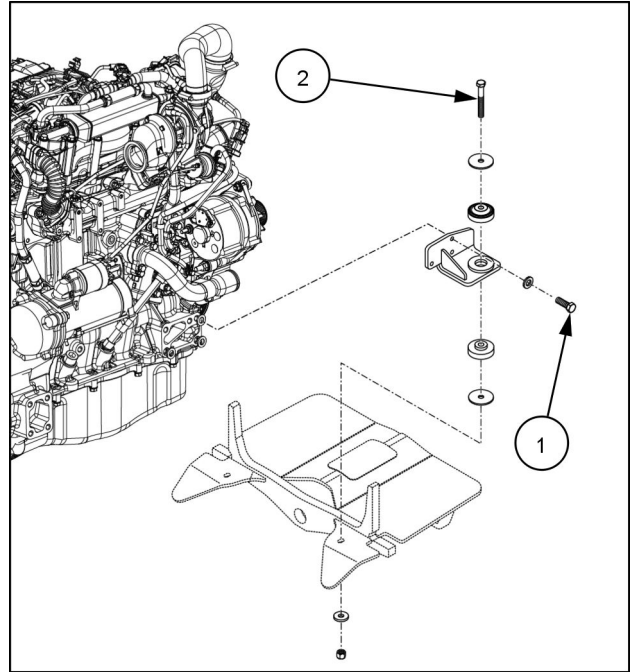

RAIL14TLB1008BA 3

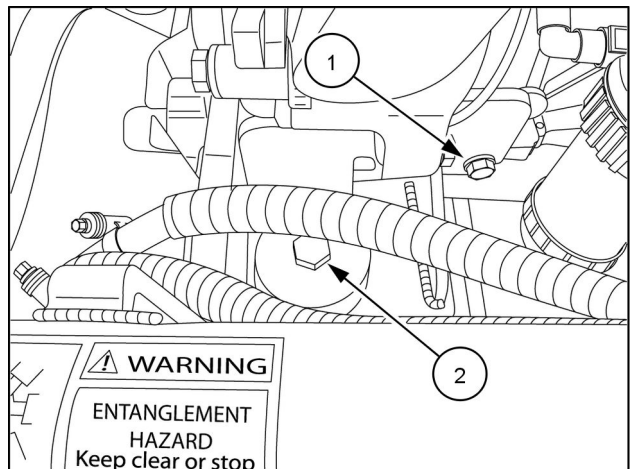

RAPH12FRK0103BA 4

Specification

Mount-to-engine torque	89 - 107 N·m (66 - 79 lb ft)
Mount-to-frame torque	178 - 240 N·m (131 - 177 lb ft)

6. Tighten all the bell housing bolts to specification.

NOTE: View is from underneath the machine.

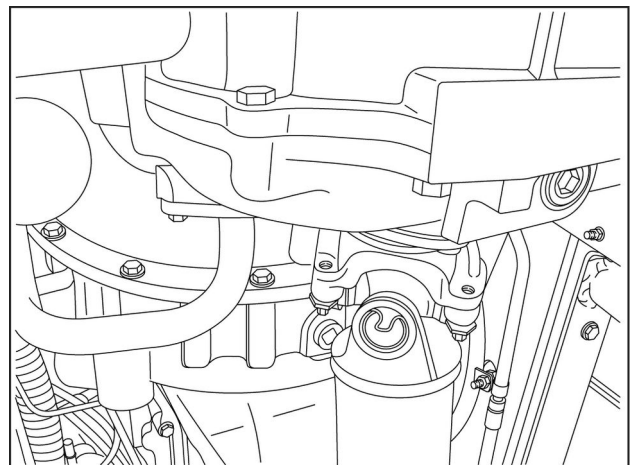

RAPH11TLB0020BA 5

<https://www.ebooklibonline.com>

Hello dear friend!

Thank you very much for reading.

Enter the link into your browser.

The full manual is available for immediate download.

<https://www.ebooklibonline.com>