

**CASE**  
**130 and 180**  
**Compact Tractors**

**Service Manual**

9-76391

Reprinted



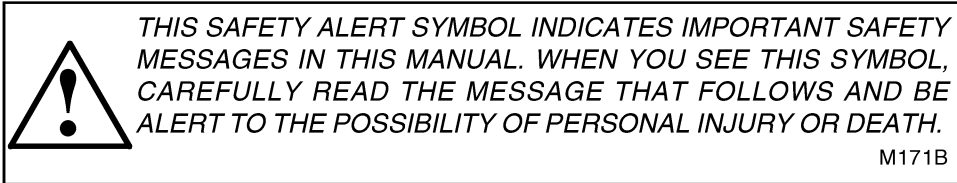



If Safety Decals on this machine use the words **Danger, Warning or Caution**, which are defined as follows:

- **DANGER:** Indicates an immediate hazardous situation which if not avoided, will result in death or serious injury. The color associated with Danger is RED.
- **WARNING:** Indicates an potentially hazardous situation which if not avoided, will result in serious injury. The color associated with Warning is ORANGE.
- **CAUTION:** Indicates an potentially hazardous situation which if not avoided, may result in minor or moderate injury. It may also be used to alert against unsafe practices. The color associated with Caution is YELLOW.

If Safety Decals on this machine are ISO two panel Pictorial, decals are defined as follows:

- The first panel indicates the nature of the hazard.
- The second panel indicates the appropriate avoidance of the hazard.
- Background color is YELLOW.
- Prohibition symbols such as   and  if used, are RED.



# WARNING

IMPROPER OPERATION OF THIS MACHINE CAN CAUSE INJURY OR DEATH. BEFORE USING THIS MACHINE, MAKE CERTAIN THAT EVERY OPERATOR:

- Is instructed in safe and proper use of the machine.
- Reads and understands the Manual(s) pertaining to the machine.
- Reads and understands ALL Safety Decals on the machine.
- Clears the area of other persons.
- Learns and practices safe use of machine controls in a safe, clear area before operating this machine on a job site.

It is your responsibility to observe pertinent laws and regulations and follow Case Corporation instructions on machine operation and maintenance.

# TABLE OF CONTENTS

## 130 AND 180 COMPACT TRACTORS

SERIES	SECTION	DESCRIPTION	FORM NUMBER
10		<b>GENERAL</b>	
	C	Specifications For K241S And K301S Engines .....	9-76411
20		<b>ENGINES</b>	
	M	Servicing The Kohler K241S And K301S Engines .....	9-76361
30		<b>FUEL SYSTEM</b>	
	N	Servicing The Carburetor And Fuel Pump .....	9-76361
40		<b>ELECTRICAL</b>	
	F	Electrical System .....	9-76371
50		<b>STEERING</b>	
	O	Servicing The Steering System .....	9-76311
60		<b>POWER TRAIN</b>	
	S	Servicing The Two Speed Transmission .....	9-76301
80		<b>HYDRAULICS</b>	
	B	Servicing The Hydraulic Pump .....	9-76291
	D	Servicing The Control Valve And Orbital Motor .....	9-76351
90		<b>ACCESSORIES</b>	
		Installing - Operating - Adjusting The 38" And 44"	
		Rotary Mowers And 44" Dozer Blade .....	9-76501
		Servicing The Rotary Mower And Dozer Blade .....	9-76461



**<https://www.ebooklibonline.com>**

Hello dear friend!

Thank you very much for reading.

Enter the link into your browser.

The full manual is available for immediate download.

**<https://www.ebooklibonline.com>**

**10**

**Series**

**General**

**SECTION**

**C**

**SPECIFICATIONS FOR**

**K 241S AND K 301S**

**ENGINES**

**USED ON**

**THE**

**130 AND 180**

**GARDEN TRACTORS**

# K241S engine

## K241S ENGINE SPECIFICATIONS

Type ----- Kohler, 1 Cylinder, 4 Stroke Cycle  
Air Cooled, "L" Head Engine  
Bore ----- 3.250 Inches  
Stroke ----- 2.880 Inches  
Piston Displacement ----- 23.9 Cubic Inches  
Compression Ratio ----- 6 to 1  
Max. Comp. at Cranking Speed (Engine at Operating  
Temperature ----- 110 to 120 PSI at Sea Level  
Crankcase Vacuum (Engine Running) --- 5 to 10 Inches Vacuum at Sea Level  
Ignition ----- 12 Volt Coil, Breaker Point

### CYLINDER BORE

Diameter of Cylinder Bore Std. A, B ----- 3.2505-3.2545 Inches  
.010 Oversize A, B + 10 ----- 3.2605-3.2615 Inches  
.020 Oversize A, B + 20 ----- 3.2705-3.2715 Inches  
.030 Oversize A, B + 30 ----- 3.2805-3.2815 Inches  
Cylinder Bore Must Be Bored or Honed Oversize If Taper or Out of Round  
Exceeds ----- .005 Inches

### PISTON AND PISTON PIN

Diameter of Std. Piston at Bottom of Skirt ----- 3.2470-3.2480 Inches  
Diameter of Std. Piston at Top of Skirt ----- 3.2425-3.2535 Inches  
(Measured Just Below Oil Ring)  
Diameter of Std. Piston at Top ----- 3.218-3.220 Inches  
Piston Pin ----- Full Floating Type, Retained in  
Place With Two Retainer Rings.  
Piston Pin Bore in Piston Std. ----- .8595-.8596 Inches  
Piston Pin Diameter Std. ----- .8591-.8593 Inches  
.005 Oversize ----- .8641-.8643 Inches  
Piston Pin Length ----- 2.738-2.753 Inches  
Piston Pin Fit in Piston (Select Fit) ----- .0000-.0003 Inches  
Piston Pin Fit in Connecting Rod ----- .0003-.0008 Inches

### PISTON RINGS

Rings Per Piston ----- (2 Compression-1 Oil)  
1st (Top) Compression-Chrome, Taper Face, Relief Indicates Top Side  
Side Clearance ----- .002-.004 Inches  
Width ----- .093-.094 Inches  
2nd Compression-Chrome, Relief Indicates Bottom Side  
Side Clearance ----- .0015-.0035 Inches  
Width ----- .093-.094 Inches  
3rd Oil Ring ----- Cast W/ Expander  
Side Clearance ----- .001-.003 Inches  
Width ----- .1860-.1870 Inches  
Ring End Gap - When Installed in Bore ----- .010-.020 Inches  
Replacement Ring Width  
1st. Comp. ----- .0925-.0935 Inches  
2nd. Comp. ----- .0665-.0675 Inches  
2nd. Comp. Rail ----- .0235-.0245 Inches  
3rd. Oil Rail ----- .0235-.0245 Inches  
3rd Oil Ring ----- .134-.135 Inches

### CONNECTING ROD

Connecting Rod Length from Center of Pin Hole  
To Center of Bearing Journal ----- 5.560-5.562 Inches  
Piston Pin Hole Diameter in Rod ----- .8596-.8599 Inches  
Inside Diameter of Rod Journal, Std. ----- 1.5005-1.5010 Inches  
Undersize ----- 1.4905-1.4910 Inches  
Connecting Rod to Crank Journal Clearance ----- .0005-.0015 Inches  
Connecting Rod to Crank End Play Clearance ----- .007-.016 Inches

### CRANKSHAFT AND BEARINGS

Type Main Bearings ----- Ball Bearings  
Crankshaft Rod Journal ----- 1.4995-1.5000 Inches

Crankshaft Rod Journal Width ----- 1.079-1.084 Inches  
Crankshaft End Play ----- .003-.020 Inches  
Measured at Bearing Plate and Shim to Proper End Play

### CAMSHAFT

Camshaft End Play ----- .005-.010 Inches  
Camshaft Pin Diameter ----- .4980-.4985 Inches  
Camshaft Inside Diameter ----- .4995-.5015 Inches  
Camshaft Pin to Camshaft Clearance ----- .001-.0035 Inches  
Camshaft Pin to Breaker Cam Clearance ----- .001-.0025 Inches

### VALVE LIFTERS

Valve Lifter Outside Diameter in Block ----- .6232-.6237 Inches  
Valve Lifter Bore in Block ----- .6245-.6255 Inches  
Valve Lifter to Block Clearance ----- .0008-.0023 Inches

### VALVES

Intake Valve Tappet Clearance (Cold) ----- .008-.010 Inches  
Exhaust Valve Tappet Clearance (Cold) ----- .017-.020 Inches  
Angle of Valve Face - Intake and Exhaust ----- 44 Degrees  
Valve Length - Intake and Exhaust ----- 4.572-4.582 Inches  
Max. Valve Face Runout - Intake ----- .0015 Inches  
Max. Valve Face Runout - Exhaust ----- .003 Inches  
Valve Head Diameter - Intake ----- 1.370-1.380 Inches  
Valve Head Diameter - Exhaust ----- 1.120-1.130 Inches  
Valve Stem Diameter - Intake ----- .3105-.3110 Inches  
Valve Stem Diameter - Exhaust ----- .3090-.3095 Inches  
Intake Valve Stem to Guide Clearance ----- .001-.0025 Inches  
Exhaust Valve Stem to Guide Clearance ----- .0025-.004 Inches

### VALVE SEATS

Seat Angle - Intake and Exhaust ----- 45 Degrees  
Max. Seat Runout - Intake and Exhaust ----- .002 Inches  
Seat Width - Intake ----- .037-.045 Inches  
Seat Width - Exhaust ----- .031-.062 Inches  
Exhaust Seat Insert ----- Replaceable  
Outside Diameter of Exhaust Insert ----- 1.2535-1.2545 Inches  
Exhaust Insert Height ----- .219-.221 Inches

### VALVE GUIDES

Valve Guide Length ----- 2.125 Inches  
Valve Guide Outside Diameter ----- .6260-.6265 Inches  
Valve Guide to Block (Press Fit) ----- .0005-.002 Inches  
Valve Guide Inside Diameter - Before Installing ----- .307-.308 Inches  
Ream Valve Guides After Installing to ----- .312-.313 Inches

### VALVE SPRINGS

Spring Free Length ----- 1.793 Inches  
Spring Pressure When Comp. to 1.469 In. (Valve Closed) --- 27 to 31 Lbs.  
Spring Pressure When Comp. to 1.165 In. (Valve Open) --- 54 to 62 lbs.

### GOVERNOR

Governor Stub Shaft Outside Diameter ----- .3735-.3740 Inches  
Governor Gear Bore for Stub Shaft ----- .3745-.3755 Inches  
Stub Shaft to Governor Gear Clearance ----- .0005-.002 Inches  
Governor Spring Free Length With 2 Lbs. Pre-Load ----- 2.62 Inches  
Governor Spring Extended to 2.88 Inches ----- 5.5 to 6.5 Pounds

## K301S ENGINE SPECIFICATIONS

Type -----	Kohler, 1 Cylinder, 4 Stroke Cycle, Air Cooled, "L" Head Engine
Bore -----	3.380 Inches
Stroke -----	3.250 Inches
Piston Displacement -----	29.07 Cubic Inches
Compression Ratio -----	6 to 1
Max. Comp. at Cranking Speed (Engine at Operating Temperature) -----	110 to 120 PSI at Sea Level
Crankcase Vacuum(Engine Running)---	5 to 10 Inches Vacuum at Sea Level
Ignition -----	12 Volt Coil, Breaker Points

### CYLINDER BORE

Diameter of Cylinder Bore Std. A, B-----	3.3745-3.3785 Inches
.010 Oversize A, B + 10 -----	3.3845-3.3855 Inches
.020 Oversize A, B + 20 -----	3.3945-3.3955 Inches
.030 Oversize A, B + 30 -----	3.4045-3.4055 Inches
Cylinder Bore Must Be Bored or Honed Oversize If Taper or Out of Round Exceeds -----	.005 Inches

### PISTON AND PISTON PIN

Diameter of Std. Piston at Top -----	3.356-3.360 Inches
Diameter of Std. Piston at Top of Skirt (Measured Just Below Oil Ring) -----	3.369-3.370 Inches
Diameter of Std. Piston at Bottom of Skirt -----	3.371-3.372 Inches
Piston Pin -----	Full Floating Type Retained In Place With Two Retainer Rings.
Piston Pin Bore In Piston, Std. -----	.8752-.8754 Inches
Piston Pin Diameter Std. -----	.8752-.8754 Inches
.005 Oversize -----	.8802-.8804 Inches
Piston Pin Length -----	2.735-2.750 Inches
Piston Pin Fit In Piston -----	One Thumb Push Fit
Piston Pin Fit In Connecting Rod -----	.0003-.0008 Inches

### PISTON RINGS

Rings Per Piston -----	(2 Compression-1 Oil)
1st(Top)Compression-Chrome, Tapered Face. Relief Indicates Top Side. Side Clearance -----	.002-.004 Inches
Width -----	.078 Inches
2nd - Compression ----- Chrome, Relief Indicates Bottom Side Side Clearance -----	.002-.004 Inches
Width -----	.078 Inches
3rd - Oil Ring ----- Cast W/Expander Side Clearance -----	.001-.003 Inches
Width -----	.1870 Inches
Ring End Gap When Installed In Bore -----	.010-.020 Inches
Replacement Ring Width	
1st Comp. -----	.077-.078 Inches
2nd Comp. -----	.077-.078 Inches
3rd Oil Rail -----	.0235-.0245 Inches
3rd Oil Ring -----	.134-.135 Inches

### CONNECTING ROD

Connecting Rod Length From Center of Pin Hole To Center of Bearing Journal -----	5.295-5.297 Inches
Piston Pin Hole Diameter In Rod -----	.8757-.8760 Inches
Inside Diameter of Rod Journal, Std. -----	1.5005-1.5010 Inches
Undersize -----	1.4905-1.4910 Inches
Connecting Rod To Crank Journal Clearance -----	.0005-.0015
Connecting Rod To Crank End Play Clearance -----	.007-.016 Inches

### CRANKSHAFT AND BEARINGS

Type Main Bearings -----	Ball Bearings
Crankshaft Rod Journal -----	1.4995-1.5000 Inches
Crankshaft Rod Journal Width -----	1.079-1.084 Inches
Crankshaft End Play -----	.003-.020 Inches
Measured at Bearing Plate and Shim to Prover End Play.	

### CAMSHAFT

Camshaft End Play -----	.005-.010 Inches
-------------------------	------------------

# K301S engine

Camshaft Pin Diameter -----	.4980-.4985 Inches
Camshaft Inside Diameter -----	.4995-.5015 Inches
Camshaft Pin to Camshaft Clearance -----	.001-.0035 Inches
Camshaft Pin to Breaker Cam Clearance -----	.001-.0025 Inches

### VALVE LIFTERS

Valve Lifter Outside Diameter In Block -----	.6232-.6237 Inches
Valve Lifter Bore In Block -----	.6245-.6255 Inches
Valve Lifter To Block Clearance -----	.008-.0023 Inches

### VALVES

Intake Valve Tappet Clearance (Cold) -----	.008-.010 Inches
Exhaust Valve Tappet Clearance (Cold) -----	.017-.020 Inches
Angle of Valve Face - Intake and Exhaust -----	44 Degrees
Valve Length - Intake and Exhaust -----	4.572-4.582 Inches
Max. Valve Face Runout - Intake -----	.0015 Inches
Max. Valve Face Runout - Exhaust -----	.003 Inches
Valve Head Diameter - Intake -----	1.370-1.380 Inches
Valve Head Diameter - Exhaust -----	1.120-1.130 Inches
Valve Stem Diameter - Intake -----	.3105-.3110 Inches
Valve Stem Diameter - Exhaust -----	.3090-.3095 Inches
Intake Valve Stem to Guide Clearance -----	.001-.0025 Inches
Exhaust Valve Stem to Guide Clearance -----	.0025-.004 Inches

### VALVE SEATS

Seat Angle - Intake and Exhaust -----	45 Degrees
Max. Seat Runout Intake and Exhaust -----	.002 Inches
Seat Width - Intake -----	.037-.045 Inches
Seat Width - Exhaust -----	.031-.062 Inches
Exhaust Seat Insert -----	Replaceable
Outside Diameter of Exhaust Insert -----	1.2535-1.2545 Inches
Exhaust Insert Height -----	.219-.221 Inches

### VALVE GUIDES

Valve Guide Length -----	2.125 Inches
Valve Guide Outside Diameter -----	.6260-.6265 Inches
Valve Guide to Block (Press Fit) -----	.0005-.002 Inches
Valve Guide Inside Diameter - Before Installing -----	.307-.308 Inches
Ream Valve Guides After Installing to -----	.312-.313 Inches

### VALVE SPRINGS

Spring Free Length -----	1.793 Inches
Spring Pressure When Comp. to 1.469 In. (Valve Closed) -----	27 to 31 Lbs.
Spring Pressure When Comp. to 1.165 In. (Valve Open) -----	54 to 62 Lbs.







### GOVERNOR

Governor Stub Shaft Outside Diameter -----	.3735-.3740 Inches
Governor Gear Bore for Stub Shaft -----	.3745-.3755 Inches
Stub Shaft to Governor Gear Clearance -----	.0005-.002 Inches
Governor Spring Free Length with 2 Lb. Pre-Load -----	2.62 Inches
Governor Spring Extended to 2.88 Inches -----	5.5 to 6.5 Inches

## GENERAL TORQUE SPECIFICATION TABLE (Revised 5-64)

USE THE FOLLOWING TORQUES WHEN SPECIAL TORQUES ARE NOT GIVEN

**NOTE:** These values apply to fasteners as received from supplier, dry, or when lubricated with normal engine oil. They do not apply if special graphited or moly-disulphide greases or other extreme pressure lubricants are used. This applies to both UNF and UNC threads.

SAE Grade No.	5		8 *			
Bolt head identification marks as per grade Note: Manufacturing Marks Will Vary						
	Torque Foot Pounds			Torque Foot Pounds		
Bolt Size	Min.	Max.	Min.	Max.		
1/4"	9	11	12	15		
5/16	15	18	24	28		
3/8	35	40	45	50		
7/16	54	60	70	80		
1/2	80	90	110	125		
9/16	110	120	160	180		
5/8	150	165	220	240		
3/4	260	280	380	420		
7/8	360	400	600	660		
1"	540	600	900	1000		
1-1/8	720	800	1280	1440		
1-1/4	1000	1100	1800	2000		
1-3/8	1460	1680	2380	2720		
1-1/2	1940	2200	3160	3560		

\* Thick nuts must be used with Grade 8 bolts

## GENERAL ENGINE TORQUE SPECIFICATION TABLE

Thread Size	Torque Inch Pounds		Torque Foot Pounds	
	UNC	UNF	UNC	UNF
Bolt Size				
1/4"	70	85		
5/16	150	165		
3/8			22	25
7/16			35	45
1/2			50	70

## SPECIAL ENGINE TORQUE SPECIFICATIONS

Cylinder Head Bolts\* ----- Torque to 280 Inch Lbs., Loosen, Retorque to 300 Inch Lbs.

Connecting Rod Bolt\* ----- Torque to 300 Inch Lbs.

Flywheel Nut ----- Torque to 100 Ft. Lbs.

Spark Plug ----- Torque to 27 Ft. Lbs.

\*Lubricate With Grease Upon Assembly

**20**

**Series**

**Engines**

**SECTION**

**M**

**SERVICING THE**

**KOHLER**

**K241S AND K301S**

**ENGINES**

## TABLE OF CONTENTS

INTRODUCTION .....	M-3
CHECKING COMPRESSION PRESSURE .....	M-3
CHECKING CRANKCASE VACUUM .....	M-3
CYLINDER HEAD VALVES, GUIDES AND SPRINGS .....	M-4
Removal, Inspection, Installation .....	M-4
TAPPET ADJUSTMENT .....	M-4
INSPECTION OF THE VALVES, GUIDES AND SPRINGS .....	M-6, M-7
REFACING INTAKE AND EXHAUST VALVES .....	M-8
INTAKE AND EXHAUST VALVE SEATS .....	M-9
Grinding and Inspection .....	M-9
ENGINE AND ATTACHING PARTS .....	M-10
Removal and Installation .....	M-10
ENGINE BLOCK .....	M-12
Disassembly .....	M-12
PISTON AND CONNECTING ROD .....	M-14
Disassembly, Inspection and Assembly .....	M-14, M-15
CAMSHAFT - CRANKSHAFT AND ENGINE BLOCK .....	M-16, M-17
Inspection .....	M-16, M-17
ENGINE BLOCK .....	M-18
Assembly .....	M-18

## Introduction

This manual covers servicing the Kohler 10HP 241 S and 12HP 301 S engines. There are some minor differences between these engines such as the bore and stroke. The difference will be indicated in the manual when they appear. These engines are of the 4 cycle type, splash oil lubrication, cast iron block and electric starting.

### **IMPORTANT**

**REFER TO THE SPECIFICATIONS SECTION OF THIS MANUAL FOR DIMENSIONS, TOLERANCES, ETC. WHEN SERVICING THIS ENGINE. THESE DATA ARE NOT INCLUDED IN THIS SECTION.**

## **CHECKING COMPRESSION PRESSURE**

Should you receive a service complaint dealing with excessive oil consumption, loss of power, hard starting, rough running or excessive smoke, check the compression pressure and the crankcase vacuum.

1. Steam clean engine thoroughly.
2. Warm up engine to operating temperature.
3. Remove the spark plug and shut off the fuel valve.
4. With the speed control lever in neutral or brake position, use a compression gauge similar to that shown in figure M-1.
5. Crank the engine with the starter and check the compression pressure, refer to Specification Section. If the pressure is 20 PSI or more below the specified pressure,

leaking valves or excessive ring clearance is indicated.

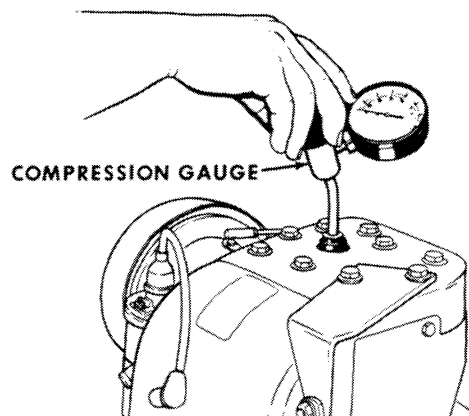

Figure M-1

## **CHECKING CRANKCASE VACUUM**

The crankcase breather maintains a partial vacuum in the crankcase. To check vacuum proceed as follows:

1. Drill and tap a 1/8" NPT in a 3/4" pipe plug or use a 1/8" to 3/4" pipe reducing bushing. Install in place of the engine oil dipstick and plug.
2. Attach vacuum gauge to pipe plug, Figure M-2. Start engine and run at low idle speed. Refer to Specification Section for proper vacuum.

No or low vacuum indicates a faulty breather, excessive blowby, leaking valves or worn oil seals.

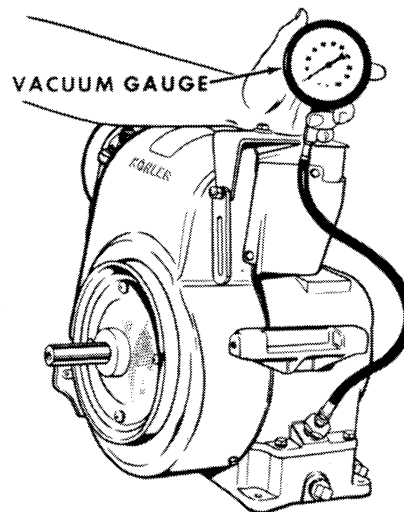

Figure M-2

# CYLINDER HEAD VALVES, GUIDES AND SPRINGS

(Refer to Figure M-3)

## Removal

Steam clean engine before doing any disassembly or service work.

Close the fuel tank shut off valve and disconnect the fuel line at the carburetor. Disconnect the choke and throttle connections at the carburetor. Disconnect governor linkage and remove carburetor (1) and baffle (2).

Remove and disassemble breather (25-31), cylinder head bolts (4). Remove the engine air deflector (5), cylinder baffle (6) and head baffles (7). Remove the generator adjusting bracket (8).

Remove the spark plug (9), wire (10), cylinder head (11) and gasket (12) from

cylinder block (13). Using a valve spring compressor, inset A, compress the valve springs (17) and remove the valve retainer locks (15). Remove the valve retainers (16), springs, spring retainers (18), and valves (19).

To remove valve guides (20), drive them down into the tappet chamber and carefully break them off. Drive the balance of the guides down and remove. **CAUTION** Be very careful not to damage the cylinder block when breaking off the guides. The exhaust valve seat (21) can be removed by using a seat removing tool, refer to inset B. Remove tappet adjusting screws (22) if they are to be replaced.

## Inspection

Remove all carbon from head, bore and valve guides. Blow out with compressed air. Refer to Pages M-6 and M-7 for inspection of valves, seats.

Inspect the tappet adjusting screws for wear and replace if worn.

Check the cylinder head for warpage by using a face plate. The head should make contact at all gasket surfaces. If it doesn't, replace cylinder head.

## Installation

Drive new valve guides (20) in place until they are flush with the bottom of the valve chamber. The guides must be reamed to size after installing, refer to Specification Section for proper dimension. Install exhaust seat (21) by cooling it in dry ice and drive into the block.

Install valves (19), spring retainers (18) springs (17) and valve retainers (16). Compress valve springs and install locks (15).

Install new head gasket (12) after soaking it in oil. Install head (11) baffles (6) and (7), air deflector (5) generator bracket (8) and head bolts (4).

Tighten head bolts to proper torque. Back off the bolts and retorqued to proper torque.

Refer to Specifications Section.

Clean, regap and install spark plug (9). Adjust tappets, refer to tappet adjustment. Install the breather assembly in the following order, stud (24) gasket (25), plate (26) with small drilled hole down, reed valve (27) and baffle (28).

Clean and lubricate filter (29) with engine oil and install. Install outer gasket (30), seal (31), cover (32) washer (33), and nut (34). Tighten the nut only enough to make a good seal.

Install baffle (2) carburetor (1) and gasket. Connect throttle and choke connections. Connect governor linkage and fuel line. Open fuel tank shutoff.

## TAPPET ADJUSTMENTS

Hand crank the engine to set piston at the DC mark of the compression stroke, inset C. Outward pressure will be felt when the thumb is placed over the spark plug opening when the piston is coming up on the compression stroke. A lighter pressure is also felt on the exhaust stroke. DO NOT CONFUSE THE TWO. Refer to Specification Section for proper tappet clearance. Using a feeler gauge, set tappets, inset D.

# Removal, Inspection and Installation

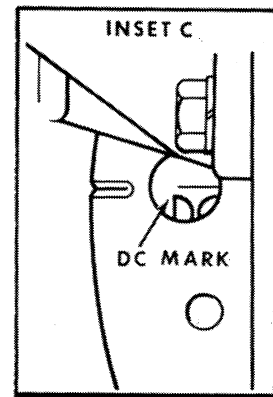
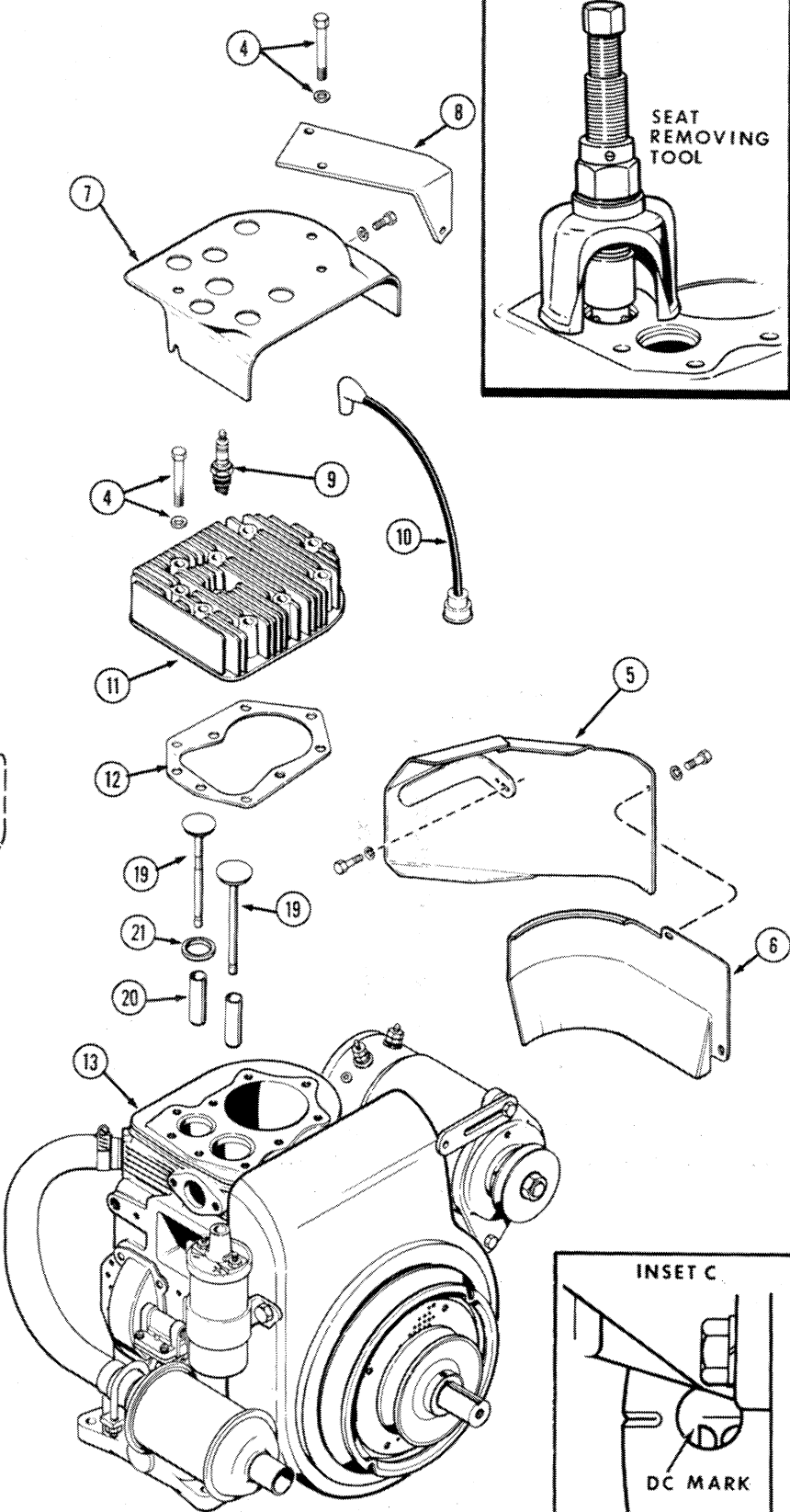
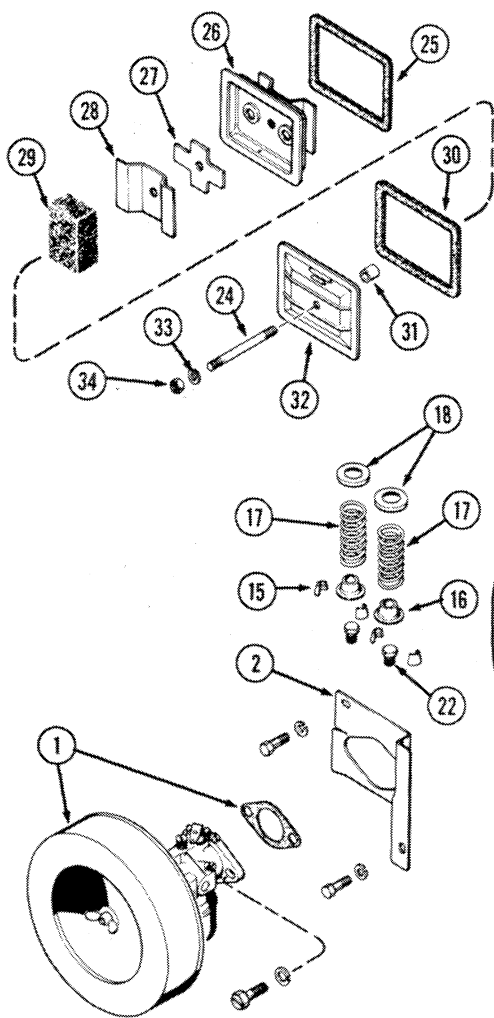
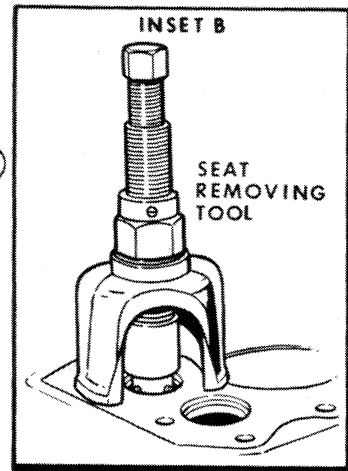
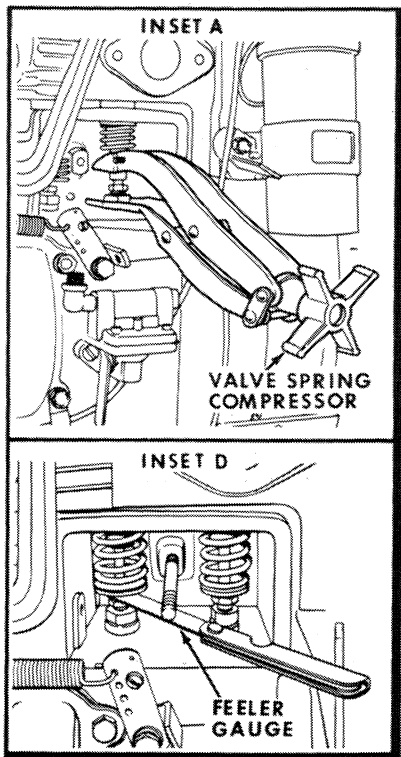

Figure M-3

# INSPECTION OF THE VALVES, GUIDES AND SPRINGS

Valve springs should be checked for flat squared ends, broken or cracked coils and correct spring pressure. Use a Valve Spring Tension Tester. Refer to "Specification" Section.

Valve guides can be checked for wear by using a bore gauge and micrometer, Figure M-4.

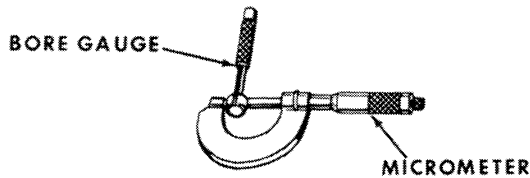

Figure M-4

The valve guide should be checked at the top, middle and bottom of the bore for wear, Figure M-5.

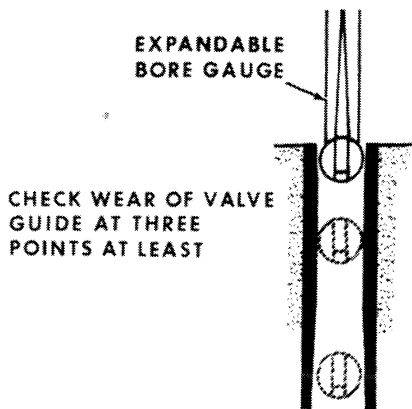

Figure M-5

The inside diameter wear limits of the valve guide should not exceed the specification given in the "Specification" Section, at any point along the bore of the guide. Replace guide if it does. Check the new valve guides after installation to make sure that the bore is not less than the inside diameter given in the "Specification" Section. Using an Arbor equal to the inside diameter of the valve guide will keep the guide from collapsing when pressed in place.

Clean the valves with a power driven fine wire brush being very careful not to scratch the valve stems. Reference is made to the different parts of the valve, Figure M-6.

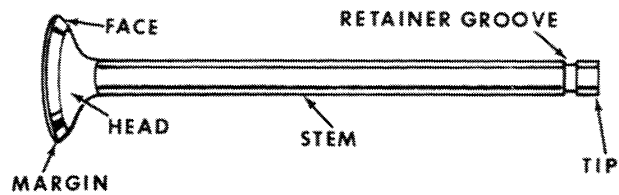

Figure M-6

Inspect the valves for excessive wear or necked stems, Figure M-7. This can be caused by lack of lubrication, plugged or dirty cooling fins or operating the engine under continuous overload at excessive engine RPM. If these conditions exist the valves and guides should be replaced.

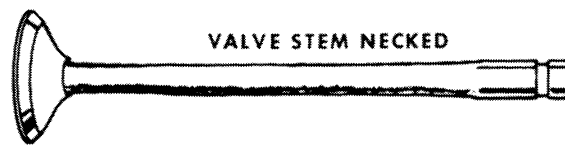

Figure M-7

Inspect the valves for deep grooves in the face, Figure M-8. This can be caused by abrasives entering the engine through the intake system or not servicing the air cleaner regularly. A leaking breather gasket can also cause this condition. If grinding the valve face will not correct this condition, replace the valves.

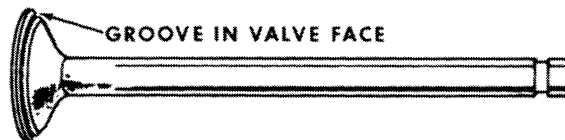

Figure M-8

Inspect the valve face and stem for rust or pitting, Figure M-9. Rust or pitting can usually be removed by grinding the valve face. If rust or pitting on the valve stem exist the valve should be replaced. These conditions can be caused by using poor quality engine oil or fuel that doesn't meet the specification given in the Operator's Manual. Rust could be caused by improper storing of the engine.

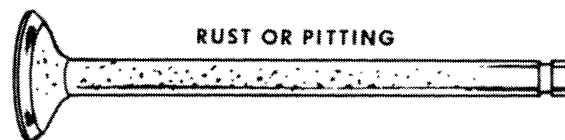

Figure M-9



**Suggest:**

**If the above button click is invalid.**

**Please download this document**

**first, and then click the above link**

**to download the complete manual.**

**Thank you so much for reading**

## INSPECTION OF THE VALVES, GUIDES AND SPRINGS (Contd)

Heavy carbon or varnish deposits on the valve, Figure M-10, should be removed before valves are ground. This condition is usually caused by worn piston rings and bore which allow too much oil to reach the combustion chamber. This condition could also be caused by worn valve guides. These conditions should be corrected or the same trouble with the valves will happen again.

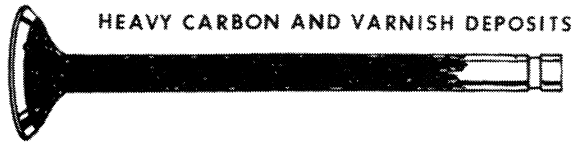

Figure M-10

Inspect the valve head for dishing and the valve face for deep burned spots, Figure M-11. These conditions can't be corrected by grinding the valves. The valves should be replaced. These conditions are usually caused by running the engine under excessive load, at high engine temperatures.

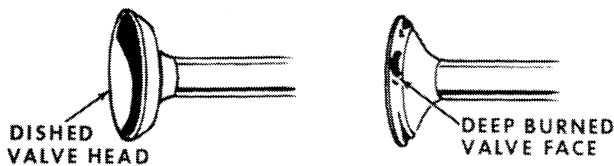

Figure M-11

Valves with worn lock grooves or the stem is worn or dished beyond the chamfer must be replaced, Figure M-12.

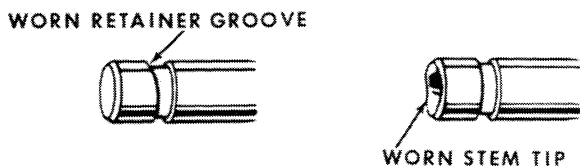

Figure M-12

The checking of the valve stem diameter can best be done with a good accurate micrometer Figure M-13.

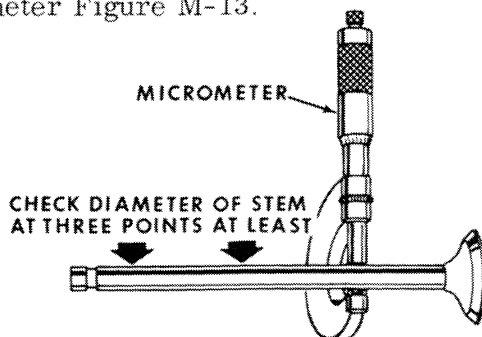

Figure M-13

The valve stem should not vary more than the wear limits given in the "Specification" Section at any point on the valve stem. If this condition exists, the valves must be replaced.

The checking of the valve face runout should be done after the valves have been ground. A Vee block type holder with a dial indicator, Figure M-14, should be used to check the valve face runout. The valve face should not vary more than the specification given in the "Specification" Section. The valve stem runout can also be checked with this Vee block and dial indicator.

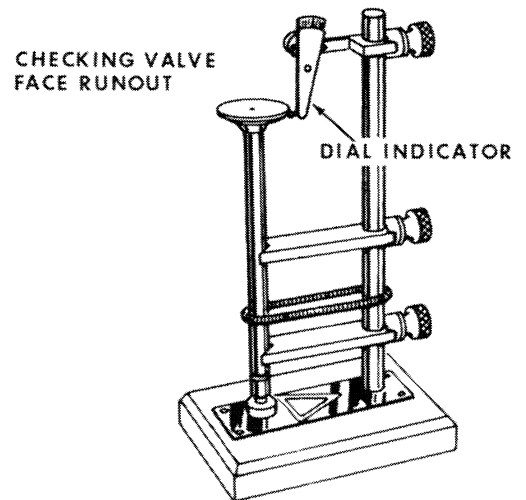

Figure M-14

### **IMPORTANT**

Small amounts of very fine pitting, Figure M-15, may be found on the surfaces of the valve faces and seats after the valves are cleaned.



Figure M-15

These are normal and will not affect engine performance. This fine pitting is caused by a normal oxidation process and can happen on any engine during the run-in-period. It is not necessary to grind valves or seats if this fine pitting is found as the pitting will generally reoccur after the engine is run for a few hours.

**<https://www.ebooklibonline.com>**

Hello dear friend!

Thank you very much for reading.

Enter the link into your browser.

The full manual is available for immediate download.

**<https://www.ebooklibonline.com>**