

6

5

3



Service Manual

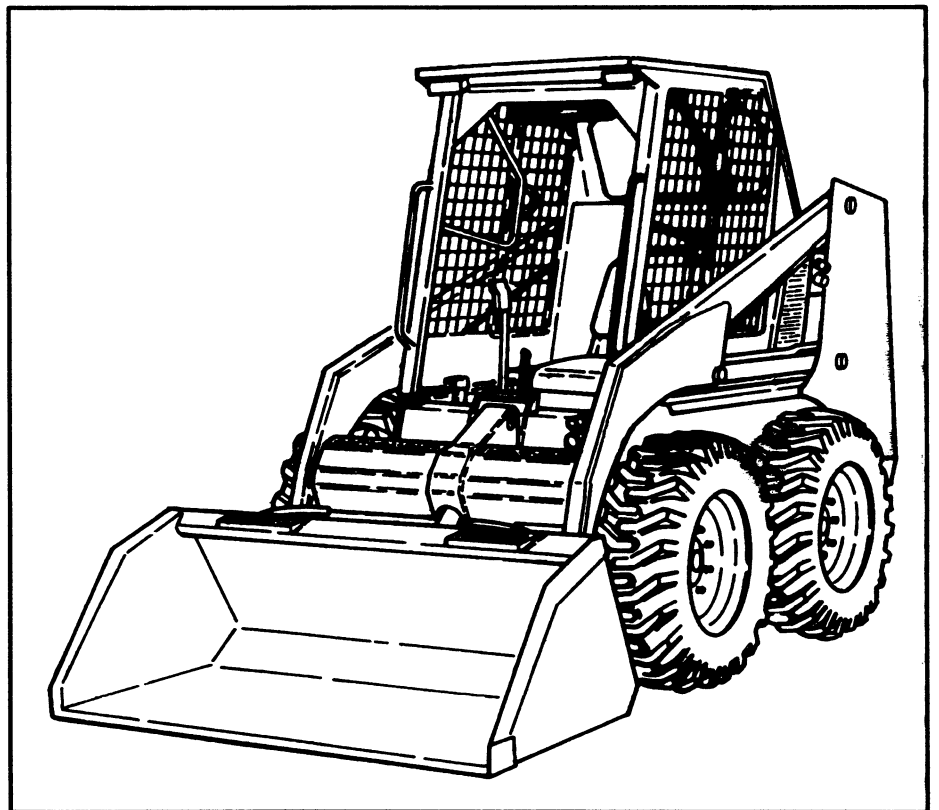

EQUIPPED WITH
BOBCAT INTERLOCK
CONTROL SYSTEM (BICS™)

**MELROE
INGERSOLL-RAND**

6724493 (12-95) Revised (1-97)

Printed in U.S.A.



© Melroe Company 1997

MAINTENANCE SAFETY



WARNING

Instructions are necessary before operating or servicing machine. Read and understand the Operation & Maintenance Manual, Operator's Handbook and signs (decals) on machine. Follow warnings and instructions in the manuals when making repairs, adjustments or servicing. Check for correct function after adjustments, repairs or service. Untrained operators and failure to follow instructions can cause injury or death.

W-2003-0903



Safety Alert Symbol: This symbol with a warning statement, means: "Warning, be alert! Your safety is involved!" Carefully read the message that follows.

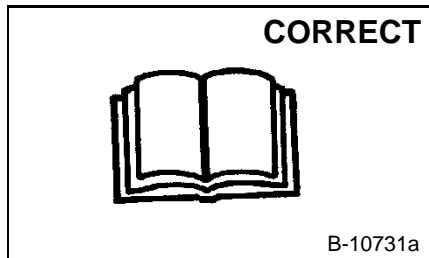

B-10731a

Never service the Bobcat Skid-Steer Loader without instructions.

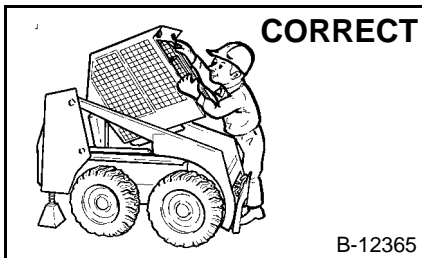

B-12365

Use the correct procedure to lift or lower operator cab.

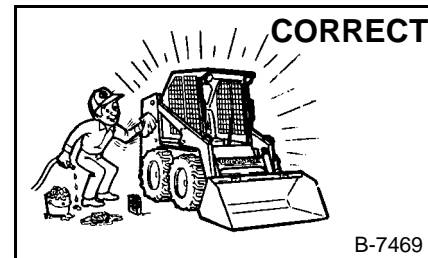

B-7469

Cleaning and maintenance are required daily.

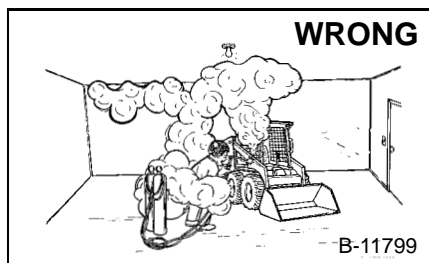

B-11799

- Have good ventilation when welding or grinding painted parts.
- Wear dust mask when grinding painted parts. Toxic dust and gas can be produced.
- Avoid exhaust fume leaks which can kill without warning. Exhaust system must be tightly sealed.

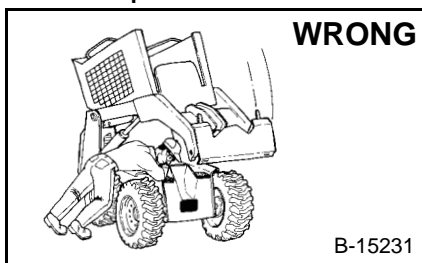

B-15231

Disconnecting or loosening any hydraulic tubeline, hose, fitting, component or a part failure can cause lift arms to drop. Do not go under lift arms when raised unless supported by an approved lift arm support device. Replace it if damaged.

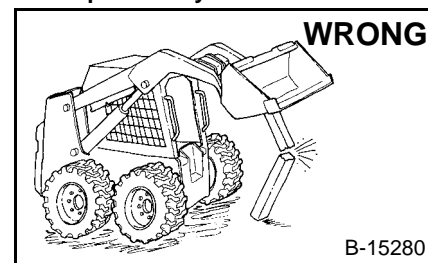

B-15280

- Never work on loader with lift arms up unless lift arms are held by an approved lift arm support device. Replace if damaged.
- Never modify equipment or add attachments not approved by Bobcat Company.

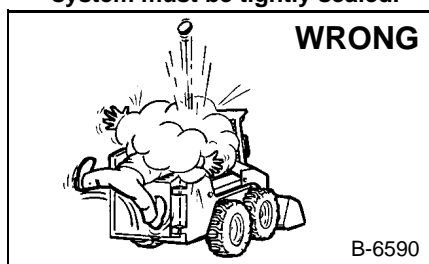

B-6590

- Stop, cool and clean engine of flammable materials before checking fluids.
- Never service or adjust loader with the engine running unless instructed to do so in the manual.
- Avoid contact with leaking hydraulic fluid or diesel fuel under pressure. It can penetrate the skin or eyes.
- Never fill fuel tank with engine running, while smoking or when near open flame.

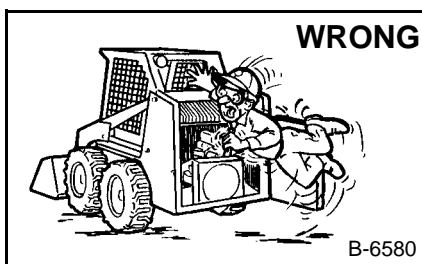

B-6580

- Keep body, jewelry and clothing away from moving parts, electrical contact, hot parts and exhaust.
- Wear eye protection to guard from battery acid, compressed springs, fluids under pressure and flying debris when engines are running or tools are used. Use eye protection approved for type of welding.
- Keep rear door closed except for service. Close and latch door before operating the loader.

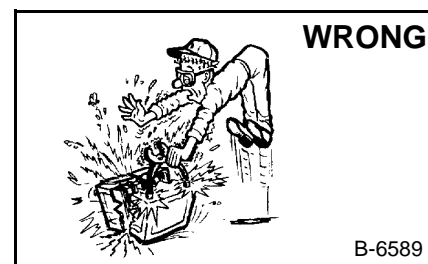

B-6589

- Lead-acid batteries produce flammable and explosive gases.
- Keep arcs, sparks, flames and lighted tobacco away from batteries.
- Batteries contain acid which burns eyes or skin on contact. Wear protective clothing. If acid contacts body, flush well with water. For eye contact flush well and get immediate medical attention.

Maintenance procedures which are given in the Operation & Maintenance Manual can be performed by the owner/operator without any specific technical training. Maintenance procedures which are **not** in the Operation & Maintenance Manual must be performed **ONLY BY QUALIFIED BOBCAT SERVICE PERSONNEL**. Always use genuine Bobcat replacement parts. The Service Safety Training Course is available from your Bobcat dealer.

MSW01-0805

ALPHABETICAL INDEX

AIR CLEANER	7-1	OIL COOLER	3-1
AIR CLEANER SERVICE	1-1	OPERATOR CAB	1-1, 5-1
ALTERNATOR	6-1	OPERATOR CAB GAS CYLINDER	5-1
ALTERNATOR BELT	1-1	OPERATOR SEAT	5-1
AXLE SEAL	4-1		
AXLE, SPROCKET AND BEARINGS	4-1	PARKING BRAKE	4-1
		PARKING BRAKE DISC	4-1
BATTERY	6-1	PEDAL INTERLOCK LINKAGE	2-1
BICS™ SYSTEM CONTROLLER	8-1	PEUGEOT ENGINE TOOL KIT	7-1
BLOWER HOUSING/FAN GEAR BOX	7-1	PISTONS AND CONNECTING RODS	7-1
BOB-TACH	5-1		
BOBCAT INTERLOCK CONTROL		RADIATOR	7-1
SYSTEM (BICS™)	8-1	REAR DOOR	5-1
		REAR GRILL	5-1
CHAINCASE COVERS	4-1	RELAY SWITCHES	6-1
CHAINCASE FLUID	4-1	REMOTE START SWITCH	1-1
CONTROL PEDALS	2-1		
CONTROL PANEL	3-1	SEAT BAR	5-1
CRANKSHAFT AND BEARINGS	7-1	SEAT BAR RESTRAINT SYSTEM	1-1
CRANKSHAFT PULLEY	7-1	SEAT BAR SENSOR	8-1
CYLINDER HEAD	7-1	SEAT SENSOR	8-1
CYLINDER LOCATION & COMPRESSION	7-1	SERVICE SCHEDULE	1-1
		SPARK ARRESTOR MUFFLER	1-1
DECIMAL & MILLIMETER EQUIVALENTS	9-1	SPRING LOADED DRIVE IDLER	3-1
DRIVE BELT	1-1	STANDARD INSTRUMENT PANEL	6-1
DRIVE BELT HOUSING	3-1	STANDARD TORQUE SPECIFICATIONS	
DRIVE BELT TENSIONER PULLEY	3-1	FOR BOLTS	9-1
DRIVE CHAIN	4-1	STARTER	6-1
		STEERING LINKAGE	3-1
ELECTRICAL SYSTEM INFORMATION	6-1	STOPPING THE BOBCAT LOADER	1-1
ENGINE	7-1	TILT CYLINDER	2-1
ENGINE BLOCK	7-1	TILT LOCK VALVE	8-1
ENGINE COOLING SYSTEM	1-1	TIMING BELT	7-1
ENGINE LUBRICATION SYSTEM	1-1	TIRE MAINTENANCE	1-1
ENGINE MUFFLER	7-1	TOWING THE LOADER	1-1
ENGINE SPECIFICATIONS	9-1	TORQUE SPECIFICATIONS FOR LOADER	9-1
ENGINE SPEED CONTROL	7-1	TRACTION LOCK	8-1
ENGINE TORQUE	7-1	TRANSPORTING THE LOADER	1-1
		TROUBLESHOOTING	2-1, 3-1 6-1, 7-1
FAN GEARBOX	1-1, 7-1		
FINAL DRIVE TRANSMISSION (CHAINCASE)	1-1	U.S. TO METRIC CONVERSION	9-1
FRONT LIGHTS	6-1		
FUEL INJECTION PUMP	7-1		
FUEL INJECTOR NOZZLE	7-1		
FUEL SYSTEM	1-1		
FUEL TANK	5-1		
GLOW PLUGS	7-1		
GLOW PLUG RELAY	6-1		
HYDRAULIC CONTROL VALVE	2-1		
HYDRAULIC CYLINDER IDENTIFICATION	2-1		
HYDRAULIC CYLINDERS	2-1		
HYDRAULIC FILTER HOUSING	2-1		
HYDRAULIC FLUID RESERVOIR	2-1		
HYDRAULIC/HYDROSTATIC			
FLUID SPECIFICATIONS	9-1		
HYDRAULIC PUMP	2-1		
HYDRAULIC SYSTEM INFORMATION	2-1		
HYDRAULIC/HYDROSTATIC SYSTEM	1-1		
HYDROSTATIC DRIVE MOTOR	3-1		
HYDROSTATIC SYSTEM INFORMATION	3-1		
INJECTION PUMP TIMING	7-1		
LIFT ARMS	5-1		
LIFT ARM SUPPORT DEVICE	1-1		
LIFT CYLINDER(S)	2-1		
LIFT LOCK BY-PASS VALVE	8-1		
LIFTING AND BLOCKING THE LOADER	1-1		
LIFTING THE LOADER	1-1		
LOADER SPECIFICATIONS	9-1		
LUBRICATING THE LOADER	1-1		
MOTOR CARRIER	4-1		

<https://www.ebooklibonline.com>

Hello dear friend!

Thank you very much for reading.

Enter the link into your browser.

The full manual is available for immediate download.

<https://www.ebooklibonline.com>

CONTENTS

FOREWORD	ii
SAFETY INSTRUCTIONS	v
SERIAL NUMBER LOCATIONS	vii
DELIVERY REPORT	vii
BOBCAT LOADER IDENTIFICATION	viii
PREVENTIVE MAINTENANCE	1-1
HYDRAULIC SYSTEM	2-1
HYDROSTATIC SYSTEM	3-1
DRIVE SYSTEM	4-1
MAIN FRAME	5-1
ELECTRICAL SYSTEM	6-1
ENGINE SERVICE	7-1
SYSTEMS ANALYSIS	8-1
SPECIFICATIONS	9-1

**PREVENTIVE
MAINTENANCE**

**HYDRAULIC
SYSTEM**

**HYDROSTATIC
SYSTEM**

**DRIVE
SYSTEM**

**MAIN
FRAME**

**ELECTRICAL
SYSTEM**

**ENGINE
SERVICE**

**SYSTEMS
ANALYSIS**







SPECIFICATION

**CALIFORNIA
PROPOSITION 65 WARNING**
Diesel engine exhaust and some of its
constituents are known to the State of California
to cause cancer, birth defects and other
reproductive harm.

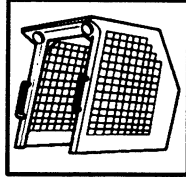
FOREWORD

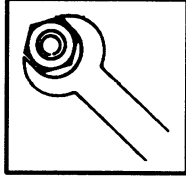
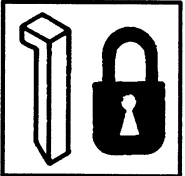
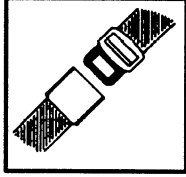
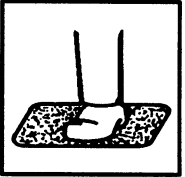
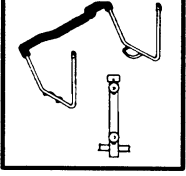
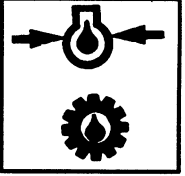
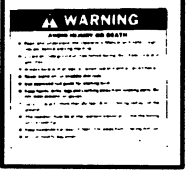
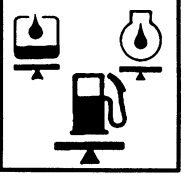
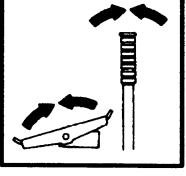
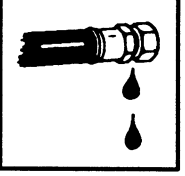
This manual is for the Bobcat loader mechanic. It provides necessary servicing and adjustment procedures for the Bobcat loader and its component parts and systems. Refer to the Operation & Maintenance Manual for operating instructions, starting procedure, daily checks, etc.

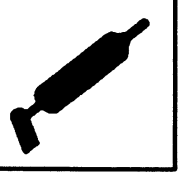
A general inspection of the following items must be made after the loader has had service or repair:

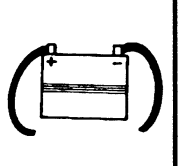
- | | | | |
|---|---|--|---|
| 1. Check that the ROPS/FOPS (Including sidescreens) is in good condition and is not modified. |  | 9. Enclosure door latches must open and close freely. |  |
| 2. Check that ROPS mounting hardware is tightened and is Melroe approved. |  | 10. Bob-Tach wedges and linkages must function correctly and be in good condition. |  |
| 3. The seat belt must be correctly installed, functional and in good condition. |  | 11. Safety treads must in good condition. |  |
| 4. The seat bar and pedal interlocks must be correctly adjusted, clean and lubricated. |  | 12. Check for correct function of indicator lamps (Optional on some models). |  |
| 5. Machine signs must be legible and in the correct location. |  | 13. Check hydraulic fluid level, engine oil level and fuel supply. |  |
| 6. Steering levers and foot pedals must return to neutral. |  | 14. Inspect for fuel, oil or hydraulic fluid leaks. |  |
| 7. Check for correct function of the work lights. |  | 15. Lubricate the loader. |  |
| 8. The parking brake must function correctly. |  | 16. Check the condition of the battery and cables. |  |

17. Inspect the air cleaner for damage or leaks. Check the condition of the element.

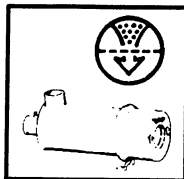

18. Check the electrical charging system.

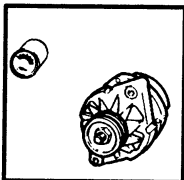

19. Check tires for wear and pressure.

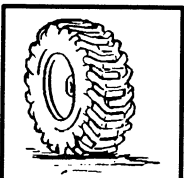

20. Inspect for loose or broken parts or connections.

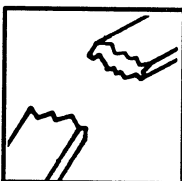

21. Operate the loader and check all functions.

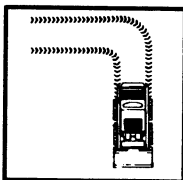

22. Check for any field modification not completed.



23. Check for correct function of the Bobcat Interlock Control System (BICS™) before the machine is returned to the customer.

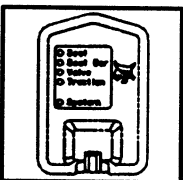

Recommend to the owner that all necessary corrections be made before the machine is returned to service.

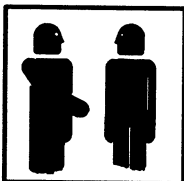

SAFETY INSTRUCTIONS

WARNING

Instructions are necessary before operating or servicing machine. Read and understand the Operation & Maintenance Manual, Handbook and signs (decals) on machine. Follow warnings and instructions in the manuals when making repairs, adjustments or servicing. Check for correct function after adjustments, repairs or service. Untrained operators and failure to follow instructions can cause injury or death.

W-2003-0199

The following publications provide information on the safe use and maintenance of the loader and attachments:

- The Delivery Report is used to assure that complete instructions have been given to the new owner and that the machine is in safe operating condition.
- The Operation & Maintenance Manual delivered with the loader gives operating information as well as routine maintenance and service procedures. It is a part of the loader and must stay with the machine when it is sold. Replacement Operation & Maintenance Manuals can be ordered from your Bobcat loader dealer.
- The loader has machine signs (decals) which instruct on the safe operation and care. The signs and their locations are shown in the Operation & Maintenance Manual. Replacement signs are available from your Bobcat loader dealer.
- The loader has a plastic Operator's Handbook fastened to the operator cab. Its brief instructions are convenient to the operator. The Handbook is available from your dealer in an English edition or a combination English, French, German, Italian, Dutch, Spanish, Portuguese, Danish, Swedish & Finnish.
- The EMI Safety Manual (available in Spanish) delivered with the loader gives general safety information.
- The Service Manual and Parts Manual are available from your dealer for use by mechanics to do shop-type service and repair work.
- The Skid-Steer Loader Operator Training Course is available through your local dealer. This course is intended to provide rules and practices for correct operation of the Bobcat loader. The course is available in English and Spanish versions.
- The Bobcat Skid-Steer Loader Safety Video is available from your Bobcat Dealer.

SAFETY INSTRUCTIONS (Cont'd)

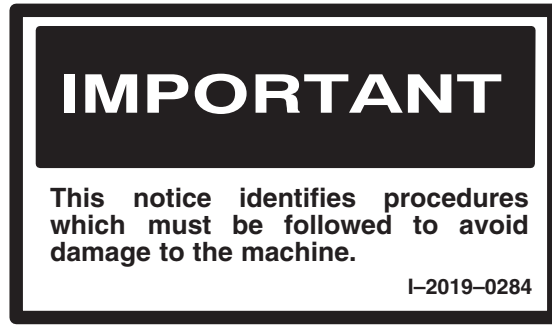

 **Safety Alert Symbol:** This symbol with a warning statement, means: “Warning, be alert! Your safety is involved!” Carefully read the message that follows.

- Wear tight fitting clothing. Always wear safety glasses when maintaining or servicing loader. Safety glasses, hearing protection or loader special applications kit are required for some work. See your dealer for Bobcat Safety equipment.
- Know where fire extinguisher and first aid kits are located and how to use them.
- Do not use the Bobcat loader where exhaust, arcs, sparks or hot components can contact flammable material, explosive dust or gases.
- The engine compartment and engine cooling system must be inspected every day and cleaned if necessary to prevent fire hazard and overheating.
- Check all electrical wiring and connections for damage. Keep the battery terminals clean and tight. Repair or replace any damaged part.
- Check fuel and hydraulic tubes, hoses and fittings for damage and leakage. Never use open flame or bare skin to check for leaks. Tighten or replace any parts that show leakage. Always clean fluid spills. Do not use gasoline or diesel fuel for cleaning parts. Use commercial nonflammable solvents.
- Follow any environmental safety regulations when disposing of used fluids such as engine oil, grease or anti-freeze.
- Do not use ether or starting fluids on this engine. It has glow plugs. These starting aids can cause explosion and injure you or bystanders.
- Always clean the loader and disconnect the battery before doing any welding. Cover rubber hoses, battery and all other flammable parts. Keep a fire extinguisher near the loader when welding. Have good ventilation when grinding or welding painted parts. Wear dust mask when grinding painted parts. Toxic dust or gas can be produced.
- Stop the engine and let it cool before adding fuel. No smoking!
- Use the procedure in the Operation & Maintenance or Service Manuals for connecting the battery.
- Use the procedure in the Operation & Maintenance or Service Manuals for cleaning the spark arrestor muffler.

A fire extinguisher is available from your local dealer. The fire extinguisher can be installed in the location shown [A].



SERIAL NUMBER LOCATIONS

Always use the serial number of the loader when requesting service information or when ordering parts. Early or later models (identification made by serial number) may use different parts, or it may be necessary to use a different procedure in doing a specific service operation.

LOADER SERIAL NUMBER

The loader serial number plate is located on the inside of the left upright, above the grill [A].

Explanation of loader Serial Number:

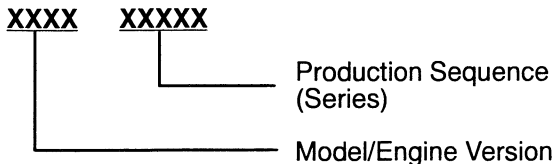

The four digit Model/Engine Combination module number identifies the model number and engine combination.

The five digit Production Sequence Number identifies the order which the loader is produced.

ENGINE SERIAL NUMBER

The serial number (Item 1) [B] is located on the engine block between engine oil fill and the injection pump.

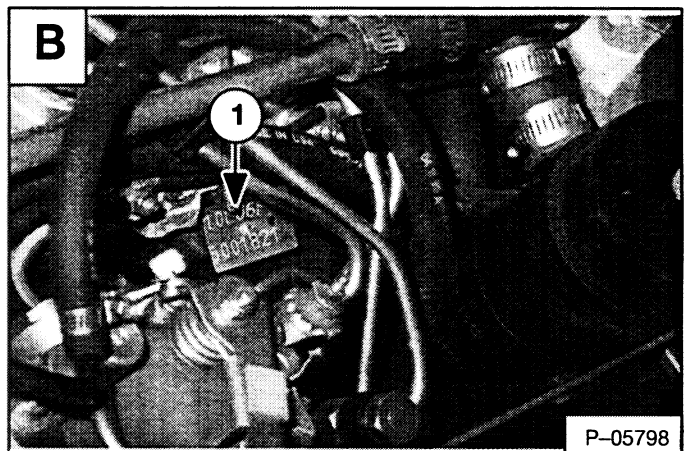
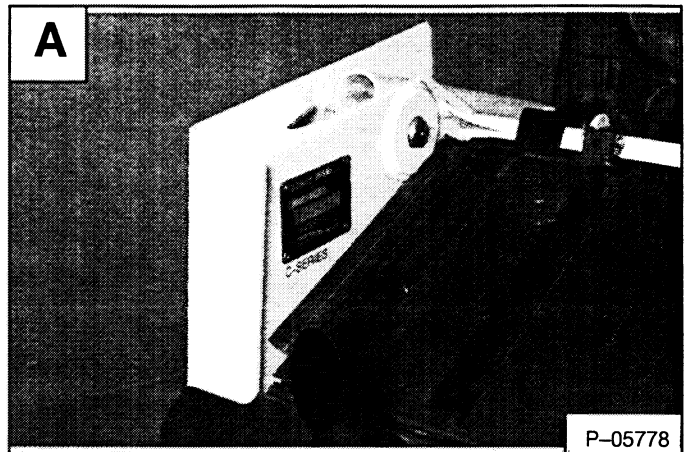

DELIVERY REPORT

The Delivery Report must be filled out by the dealer and signed by the owner or operator when the Bobcat loader is delivered. The form contents must be explained to the owner. Make sure it is filled out completely [C].

BOBCAT LOADER IDENTIFICATION

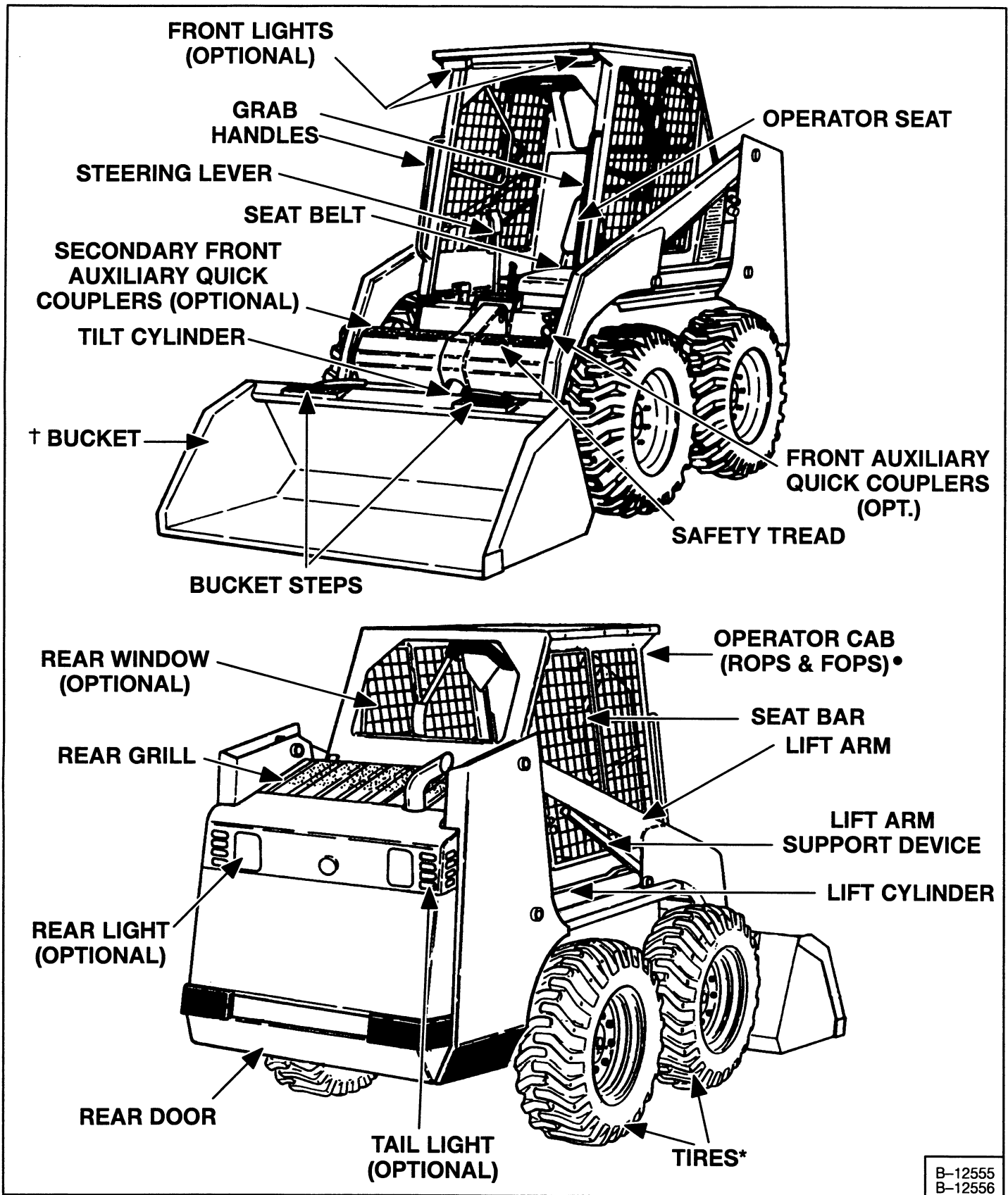

B-12555
B-12556

* TIRES – Flotation tires (optional) are shown. The Bobcat loader is factory equipped with standard tires.

† BUCKET – Several different buckets and other attachments are available for the Bobcat loader.

• ROPS, FOPS – Roll Over Protective Structure, Falling Object Protective Structure, per SAE J1040 and ISO 3471, and Falling Object Protective Structure per SAE J1043 and ISO 3449, Level I. Level II is available. The Bobcat loader is base-equipped with a standard operator cab as shown. Extra insulated cab is available as an option (Reduced noise level).

PREVENTIVE MAINTENANCE

	Page Number
AIR CLEANER SERVICE	
Replacing Filter Element	1-15
ALTERNATOR BELT	
Adjusting the Alternator Belt	1-22
Bob Tach	1-22
DRIVE BELT	
Adjusting the Drive Belt Equipped with the Fixed Drive Idler	1-29
Adjusting the Drive Belt Equipped with the Spring Loaded Drive Idler	1-31
Drive Belt Replacement	1-33
ENGINE COOLING SYSTEM	
Cleaning the Cooling System	1-20
Checking the Coolant Level	1-20
Removing Coolant From the Cooling System	1-21
ENGINE LUBRICATION SYSTEM	
Checking Engine Oil	1-18
Replacing Oil & Filter	1-18
FAN GEARBOX	
Checking and Maintaining	1-22
FINAL DRIVE TRANSMISSION (CHAINCASE)	
Checking and Adding Oil	1-28
Removing Oil From the Chaincase	1-28
FUEL SYSTEM	
Filling the Fuel Tank	1-16
Fuel Filter	1-16
Fuel Specifications	1-16
Removing Air From the Fuel System	1-17
HYDRAULIC/HYDROSTATIC SYSTEM	
Checking and Adding Fluid	1-23
Replacing Hydraulic/Hydrostatic Filter	1-23
Hydraulic Reservoir Breather Cap	1-25
Replacing Hydraulic Fluid	1-24
LIFT ARM SUPPORT DEVICE	
Disengaging the Lift Arm Support Device	1-7
Engaging the Lift Arm Support Device	1-7
LIFTING AND BLOCKING THE LOADER	
Procedure	1-4
LIFTING THE LOADER	
Four Point Lift	1-6
Single Point Lift	1-6
LUBRICATING THE LOADER	
Procedure	1-34

PREVENTIVE MAINTENANCE (Cont'd)

	Page Number
OPERATOR CAB	
Description	1-8
Lowering the Operator Cab	1-9
Raising the Operator Cab	1-8
Lowering the Operator Cab (Hand Controls)	1-11
Raising the Operator Cab (Hand Controls)	1-10
Emergency Exit	1-12
Pivot Pins	1-35
 REMOTE START SWITCH	
Procedure	1-36
 SEAT BAR RESTRAINT SYSTEM	
Description (Foot Controls)	1-13
Seat Bar Inspection (Foot Controls)	1-13
Seat Bar Maintenance (Foot Controls)	1-13
Description (Hand Controls)	1-14
Seat Bar Inspection (Hand Controls)	1-14
Seat Bar Maintenance (Hand Controls)	1-14
 SERVICE SCHEDULE	
Chart	1-3
 SPARK ARRESTOR MUFFLER	
Cleaning Procedure	1-26
 STOPPING THE BOBCAT LOADER	1-5
 TIRE MAINTENANCE	
Tire mounting	1-27
Tire Rotation	1-27
Wheel Nuts	1-27
 TOWING THE LOADER	
Procedure	1-5
 TRANSPORTING THE LOADER	
Procedure	1-5

SERVICE SCHEDULE

Maintenance work must be done at regular intervals. Failure to do so will result in excessive wear and early failures. The service schedule is a guide for correct maintenance of the Bobcat loader.



WARNING

Instructions are necessary before operating or servicing machine. Read Operation Maintenance Manual, Handbook and signs (decals) on machine. Follow warnings and instructions in the manual when making repairs, adjustments or servicing. Check for correct function after adjustments, repairs or service. Failure to follow instructions can cause injury or death.

W-2003-1289

SERVICE SCHEDULE		HOURS				
ITEM	SERVICE REQUIRED	8-10	50	100	250	1000
Engine Oil	Check the oil level and add oil as needed.					
Air Cleaner	Check condition indicator or display panel. Service only when required.					
Engine Cooling System	Clean debris from oil cooler, radiator & grill. Check coolant level cold in recovery tank. Fill with recommended coolant as needed.					
Lift Arms, Cyl., Bob-Tach Pivot Pins and Wedges	Lubricate with multi-purpose lithium based grease (13 places).					
Engine Air System	Check for damaged components.					
Tires	Check for damaged tires and correct air pressure.					
Seat Belt, Seat Bar & Pedal Interlocks	Check the condition of seat belt. Check the seat bar & pedal interlocks for correct operation. Clean dirt and debris from moving parts.					
Bobcat Interlock Control System (BICS™)	Check BICS functions. Clean dirt, debris or objects from under or behind seat as required.					
Safety Signs and Safety Tread	Check for damaged signs (decals) and safety tread. Replace any signs or safety treads that are damaged or worn.					
Operator Cab	Check the fastening bolts, washers & nuts. Check the condition of cab.					
Fuel Filter	Remove the trapped water.					
Hyd. Fluid, Hoses & Tubelines	Check fluid level & add as needed. Check for damage & leaks. Repair & replace as needed.					
Final Drive Trans. (Chaincase)	Check oil level.					
Battery	Check cables, connections & electrolyte level. Add distilled water as needed.					
Control Pedals & Steering	<input type="checkbox"/> Check for correct operation. Repair or adjust as needed.					
Wheel Nuts	Check for loose wheel nuts & tighten to 105-115 ft.-lbs. (142-156 Nm) torque.					
Parking Brake	Check operations & adjust as needed.					
Alternator Belt	Check tension & adjust as needed.					
Engine Oil & Filter	Replace oil & filter.					
Spark Arrestor Muffler	* Clean the spark chamber.					
Engine/Hydro. Drive Belt	Check for wear or damage. Adjust as needed.					
Fuel Filter	Replace filter element.					
Steering Shaft	● Grease two fittings.					
Hyd./Hydro. Filter	Replace the filter element.					
Hyd. Reservoir Breather Cap	Replace the reservoir breather cap.					
Fan Drive Gearbox	Check gear lube level.					
Final Drive Trans.	Replace the oil in the chaincase.					
Hyd. Reservoir	Replace the fluid.					
Hydraulic Motors	Replace the case drain filters (2).					
Bobcat Interlock Control System (BICS™)	Check lift arm by-pass control.					

- Check wheel nut torque every 8 hours for the first 24 hours.
- Also replace hydraulic/hydrostatic filter element when the transmission warning light comes ON.
- Or every 12 months.
- * Inspect the new belt after first 50 hours.

PREVENTIVE MAINTENANCE

WARNING

Instructions are necessary before operating or servicing machine. Read Operation & Maintenance Manuals, Handbook and signs (decals) on machine. Follow warnings and instructions in the manuals when making repairs, adjustments or servicing. Check for correct function after adjustments, repairs or service. Failure to follow instructions can cause injury or death [A].

W-2003-1289

LIFTING AND BLOCKING THE LOADER

Procedure

Always park the loader on a level surface.

WARNING

Put jackstands under the front axles and rear corners of the frame before running the engine for service. Failure to use jackstands can allow the machine to fall or move and cause injury or death.

W-2017-0286

Put floor jack under the rear of the loader [B].

Lift the rear of the loader and install jackstands [B].

Put the floor jack under the front the loader [C].

Lift the front of the loader and put jackstands under the axle tubes [C].

NOTE: Make sure the jackstands do not touch the tires.

A



B-07023

B

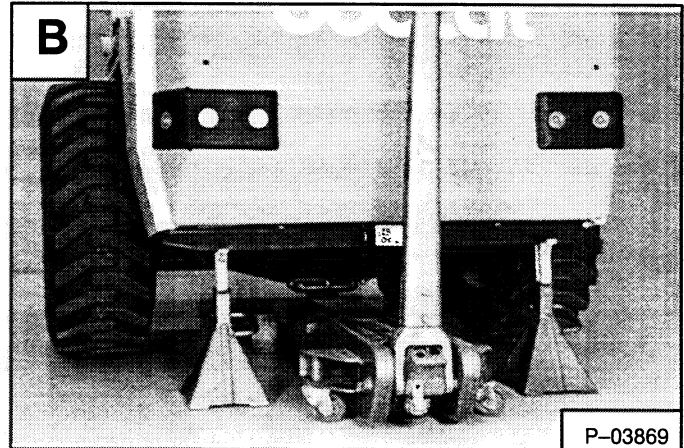

P-03869

C

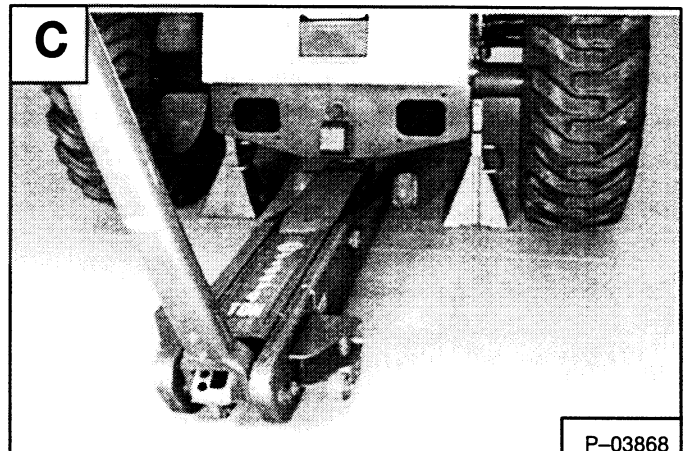

P-03868

TRANSPORTING THE LOADER

Procedure

! WARNING

Adequately designed ramps of sufficient strength are needed to support the weight of the machine when loading onto a transport vehicle. Wood ramps can break and cause personal injury.

W-2058-0494

A loader with an empty bucket or no attachment must be loaded backward onto the transport vehicle [A].

Be sure the transport and towing vehicles are of adequate size and capacity.

Use the following procedure to fasten the Bobcat loader to the transport vehicle to prevent the loader from moving during sudden stops or when going up or down slopes [B].

Lower the bucket or attachment to the floor. Stop the engine. Engage the parking brake. Install chains at the front and rear loader tie down positions (Inset) [B]. Fasten each end of the chain to the transport vehicle.

TOWING THE LOADER

Procedure

To prevent damage to the loader's hydrostatic system, the loader must be towed only a short distance at slow speed. (Example: Moving the loader onto a transport vehicle.)

The towing chain (or cable) must be rated at 1-1/2 times the weight of the loader. (See *SPECIFICATIONS*, Page 9-1.)

- Turn the key switch to ON and press the Traction Lock Override button.
- Tow the Bobcat at 2 MPH (3,2 km/hr.) or less for not more than 25 feet (7,6 meters).

If the electrical system is not functioning part of the brake system must be disassembled to move the loader. (See *TRACTION LOCK Removal and Installation* procedure Page 8-1.)

STOPPING THE BOBCAT LOADER

When the steering levers are moved to the neutral position, the hydrostatic transmission will act as a *service brake* and stop the loader.

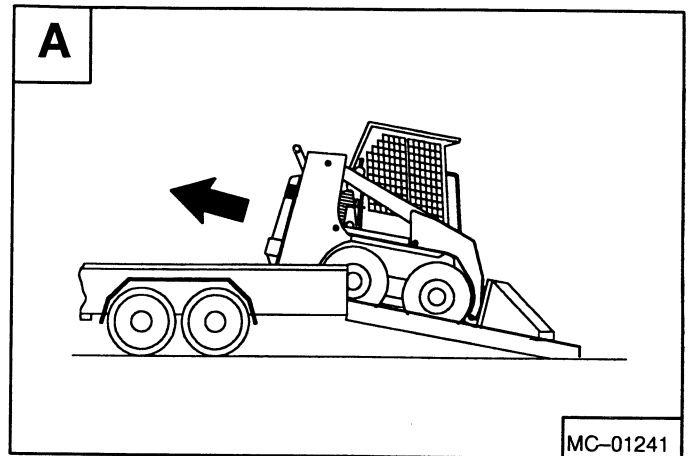

MC-01241

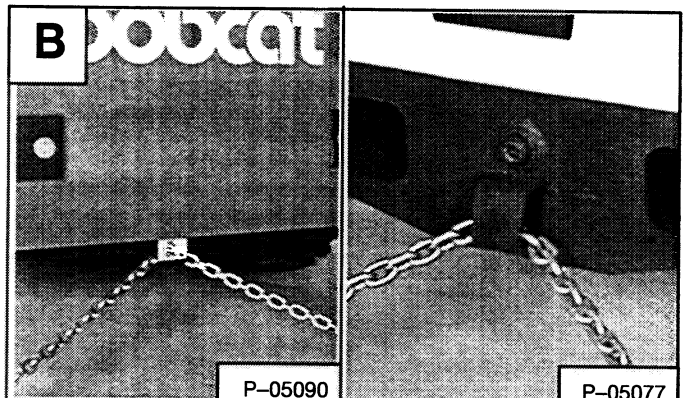

P-05090

P-05077

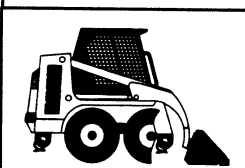
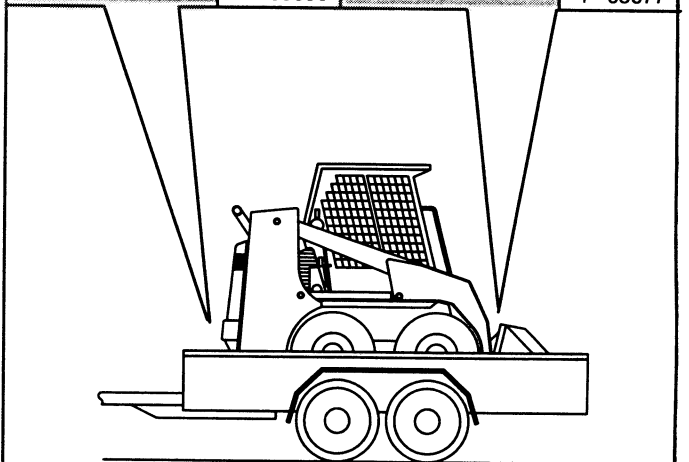

6707867

MC-01242

LIFTING THE LOADER

Four Point Lift

⚠ WARNING

AVOID INJURY OR DEATH

- Before lifting, check fasteners on four point lift.
- Never allow riders in the cab or bystanders within 15 feet (5 meters) while lifting the machine.

W-2046-1290

The loader can be lifted with the four point lift which is available as a kit from your Bobcat loader dealer.

Attach cables or chains to lift eyes as shown [A].

Single Point Lift

⚠ WARNING

AVOID INJURY OR DEATH

- Before lifting, check fasteners on single point lift and operator cab.
- Assemble front cab fasteners as shown in manual.
- Never allow riders in the cab or bystanders within 15 feet (5 meters) while lifting the machine.

W-2007-1285

The loader can also be lifted with the single point lift which is available as a kit from your Bobcat loader dealer.

Install the kit and lift as shown [B].

The single point lift, supplied by Melroe Company is designed to lift and support the Bobcat loader without affecting roll over and falling object protection features of the operator cab.

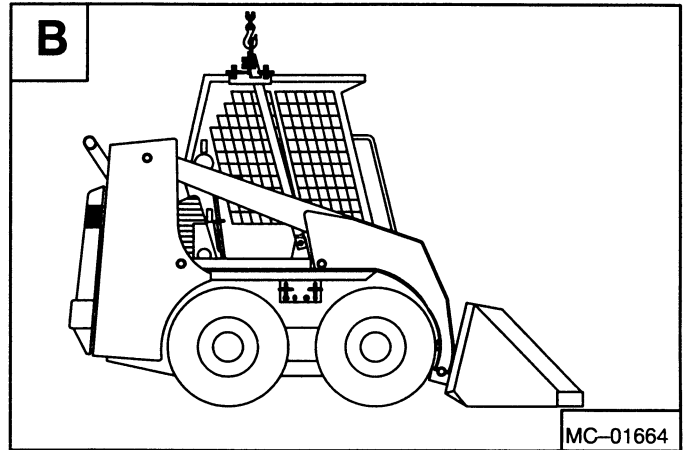
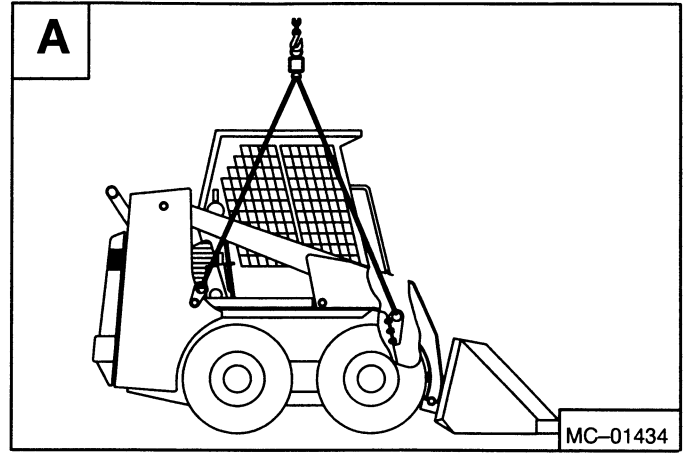

LIFT ARM SUPPORT DEVICE

! WARNING

Never work on a machine with the lift arms up unless the lift arms are secured by a lift arm support device. Failure to use an approved lift arm support device can allow the lift arms or attachment to fall and cause injury or death.

W-2059-0991

Engaging the Lift Arm Support Device

Maintenance and service work can be done with the lift arms lowered. If the lift arms must be raised for Service, use the following procedure:

Put jackstands under the rear corners of the loader.

Disconnect the spring from the lift arm support device retaining pin (Item 1) [A], hold onto the lift arm support device (Item 2) [A] and remove the retaining pin.

Lower the lift arm support device on top of the lift cylinder. Hook the free end of the spring (Item 1) [B] to the lift arm support device so there will be no interference with the support device engagement.

With the operator in the seat, seat belt fastened and seat bar lowered, start the engine.

Raise the lift arms, until the lift arm support device drops onto the lift cylinder rod [C].

Lower the lift arms slowly until the support device is held between the lift arm and the lift cylinder. Stop the engine. Raise the seat bar and move pedals until both pedals lock.

Install pin (Item 1) [C] into the rear of the lift arm support device below the cylinder rod.

Disengaging the Lift Arm Support Device

Remove the pin from the lift arm support device.

Connect the spring (Item 1) [D] from the lift arm support device to the bracket below the lift arms.

With the operator in the seat, seat belt fastened and seat bar lowered, start the engine.

Raise the lift arms a small amount and the spring will lift the support device off the lift cylinder rod. Lower the lift arms. Stop the engine.

Raise the seat bar and move pedals until both pedals lock.

Disconnect the spring from the bracket.

Raise the support device into storage position and insert pin through lift arm support device and bracket [A].

Connect spring to pin [A].

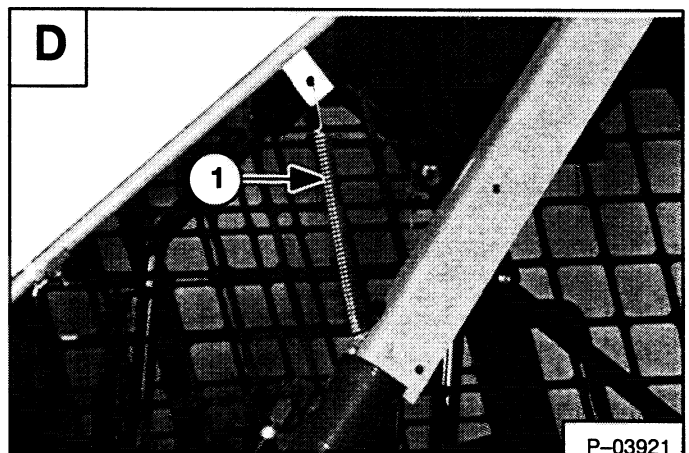
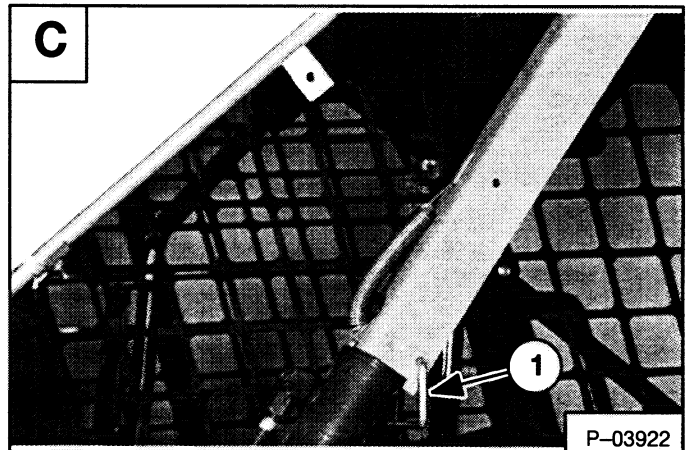
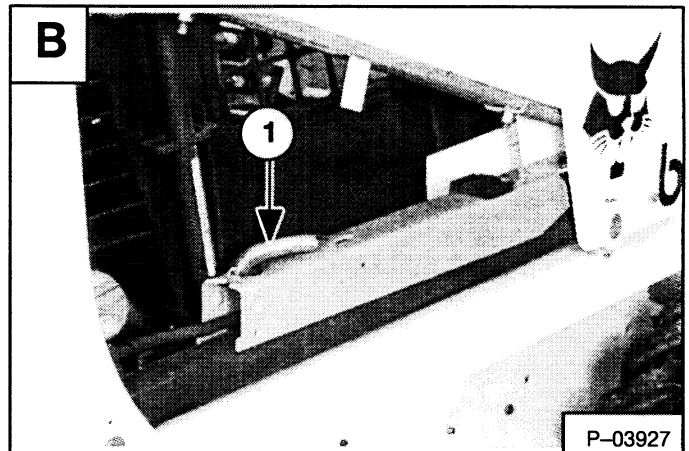
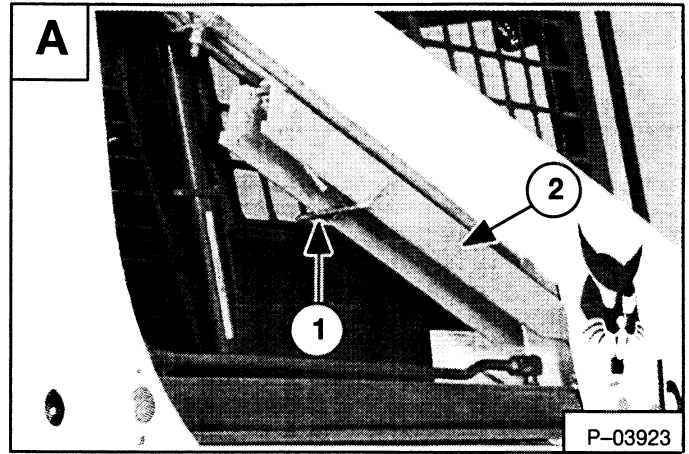

OPERATOR CAB

Description

The Bobcat loader has an operator cab (ROPS and FOPS) as standard equipment to protect the operator from rollover and falling objects. Check with your dealer if the operator cab has been damaged. The seat belt must be worn for roll over protection.

ROPS/FOPS Roll Over Protective Structure per SAE J104 and ISO 3471, and Falling Object Protective Structure per SAE J1043 and ISO 3449, Level I. Level II is available.

Level I – Protection from falling bricks, small concrete blocks and hand tools encountered in operations such as highway maintenance, landscaping, and other construction site services.

Level II – Protection from falling trees, rocks; for machines involved in site clearing, overhead demolition or forestry.

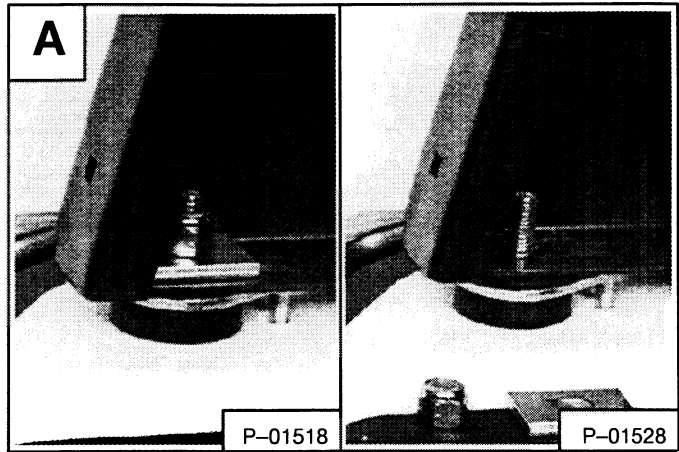

⚠ WARNING

Never modify operator cab by welding, grinding, drilling holes or adding attachments unless instructed to do so by Melroe Company. Changes to the cab can cause loss of operator protection from rollover and falling objects, and result in injury or death.

W-2069-1285

Raising the Operator Cab

Stop the loader on a level surface. Lower the lift arms. If the lift arms must be up while raising the operator cab, install the lift arm support device. (See Page 1-7.)

⚠ WARNING

Before the cab or the lift arms are raised for service, jackstands must be put under the rear corners of the frame. Failure to use jackstands may allow the machine to tip backward causing injury or death.

W-2014-1285

IMPORTANT

Use care when raising or lowering the operator cab to prevent damaging the shaft of the lift lock by-pass valve.

I-2070-0495

Loosen the nut (both sides) at the front corner of the operator cab [A].

Remove the nut and plate (both sides) [A].

Lift on the grab handle and bottom of the operator cab slowly until the cab latching mechanism engages and the cab is all the way up [B].

OPERATOR CAB (Cont'd)

Lowering the Operator Cab

NOTE: Make sure the seat bar is fully raised or lowered when lowering the cab. Always use the grab handles to lower the cab.

Pull down on the bottom of the operator cab until it stops at the latching mechanism. Release the latching mechanism and pull the cab all the way down [A].

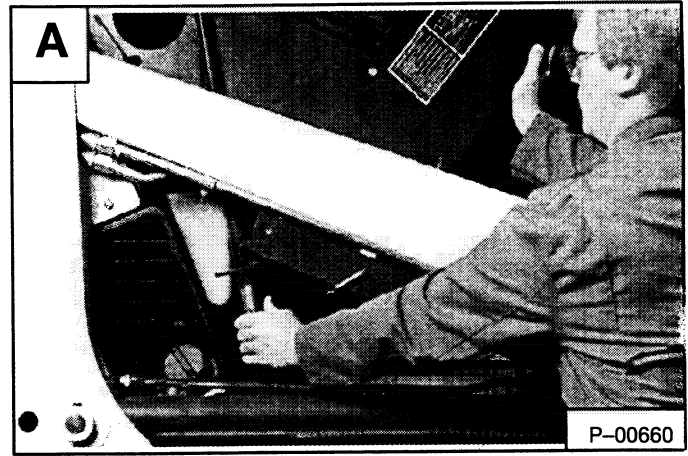

Install the plate and nut (both sides) [B].

Tighten the nuts to 40–50 ft.-lbs. (54–68 Nm) torque.

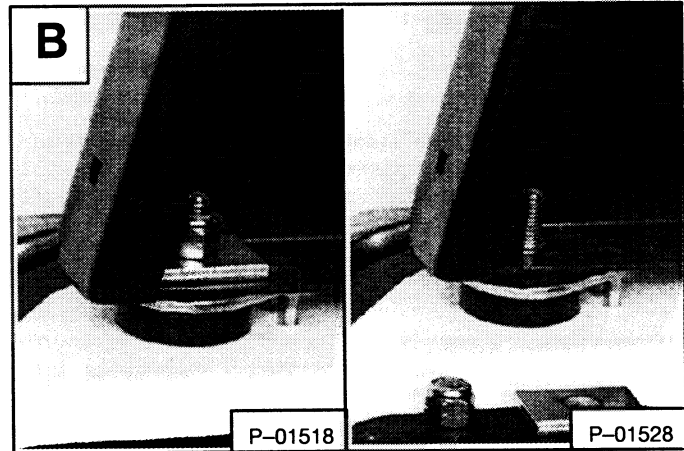

OPERATOR CAB (Hand Controls)

Raising the Operator Cab

Stop the loader on the level surface. Lower the lift arms. Stop the engine. If the lift arms must be up while raising the operator cab, install the lift arm support device. (See Page 1-1.)

! WARNING

Before the cab or the lift arms are raised for service, jackstands must be put under the rear corners of the frame. Failure to use jackstands can allow the machine to tip backward causing injury or death.

W-2014-0895

Disconnect the control linkage joint from the bottom hole (work position) and move to the TOP hole on the control handle (both sides) [A].

Both control handles must be in the vertical position so there will be no cab interference with the steering levers when the operator cab is raised or lowered.

! WARNING

AVOID INJURY OR DEATH

Accidental movement of the loader, the lift arms or the attachment can occur if the lift or tilt control handles are not positioned correctly before lifting or lowering the cab.

Move control linkage to top hole in handles as shown, so cab does not hit handles when being lifted or lowered.

W-2157-0594

Loosen and remove the nut (both sides) from the front corner of the operator cab [B].

! WARNING

Never modify operator cab by welding, grinding, drilling holes or adding attachments unless instructed to do so by Melroe Company. Changes to the cab can cause loss of operator protection from rollover and falling objects, and result in injury or death.

W-2069-1285

! WARNING

AVOID INJURY OR DEATH

When operator cab is equipped with a cab enclosure kit (front door, side windows and top window) and other accessories, the cab will not stay in the fully raised position. Use a chain hoist to secure cab in fully raised position or lower cab until it rests against the cab latch on the gas spring.

W-2156-0594

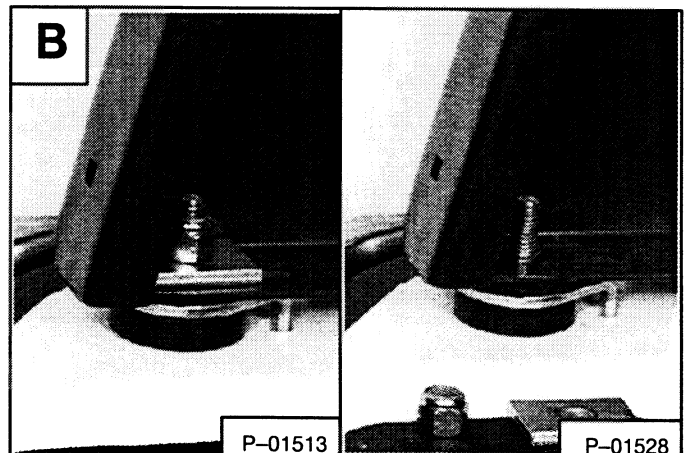
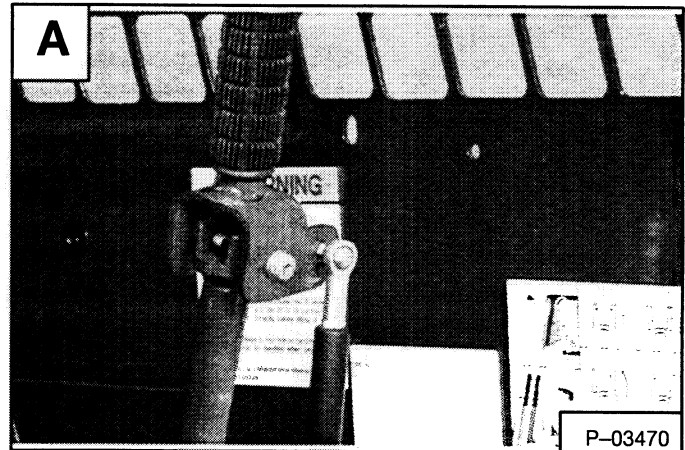

OPERATOR CAB (Cont'd)

Raising the Operator Cab (Hand Controls) (Cont'd)

Lift on the grab handle and bottom of the operator cab slowly until the cab latching mechanism engages and the cab is all the way up [A].



Lowering the Operator Cab (Hand Controls)

NOTE: Make sure the seat bar is fully raised or lowered when lowering the cab. Use the grab handles to lower the cab.

Pull down on the bottom of the operator cab until it stops at the latching mechanism. Release the latching mechanism and pull the cab all the way down [B].



Install the plate and nut (both sides) [C].

Tighten the nuts to 40–50 ft.-lbs. (54–68 Nm) torque.

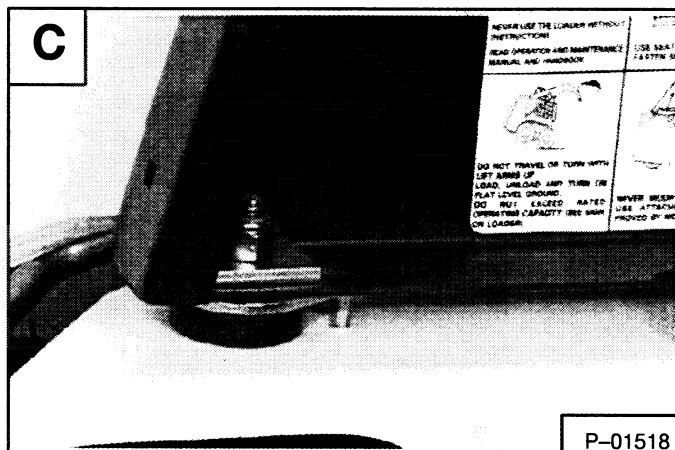

Move the control linkage from the top hole to the BOTTOM hole (work position) on the control handle (both sides) [D].



Emergency Exit

The front opening on the operator cab and rear window provide exits.

To exit through the rear window, use the following procedure:

Pull on the tag on the top of the rear window to remove the rubber cord **[A]**.

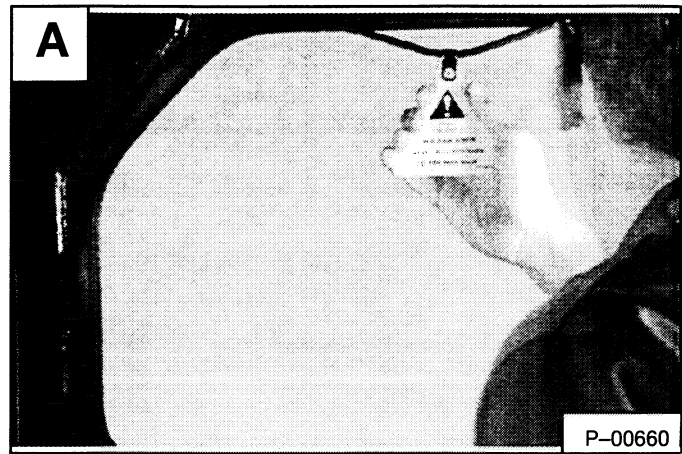

Push the rear window out of the rear of the operator cab.

Exit through the rear of the operator cab **[B]**.

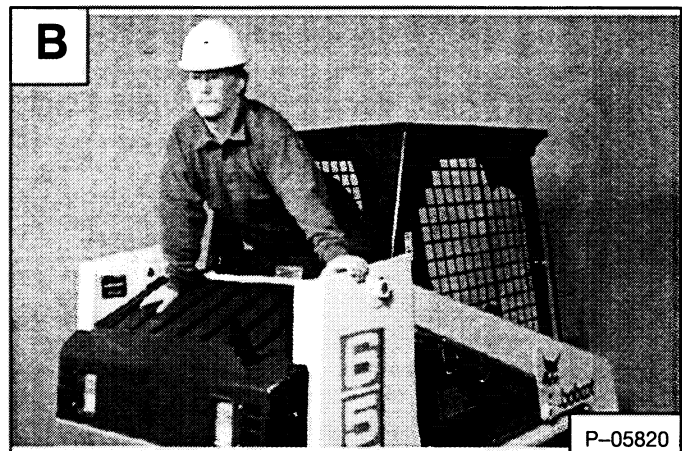

SEAT BAR RESTRAINT SYSTEM

Description (Foot Controls)

The seat bar restraint system has a pivoting seat bar with arm rests and has spring loaded interlocks for the lift and tilt control pedals. The operator controls the use of the seat bar. The seat bar in the down position helps to keep the operator in the seat. The interlocks require the operator to lower the seat bar in order to operate the foot pedal controls. When the seat bar is up, the lift and tilt pedals are locked when returned to the neutral position.

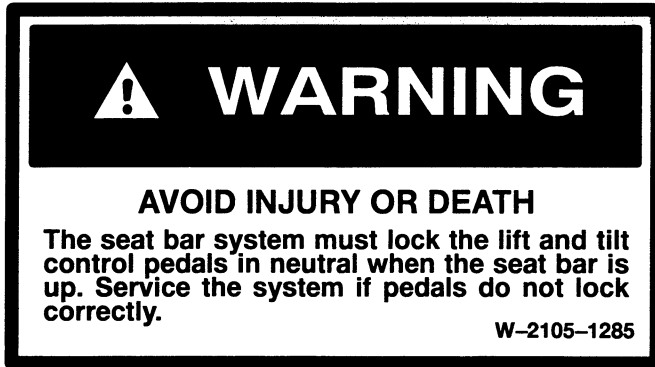

Seat Bar Inspection (Foot Controls)

Sit in the seat and fasten the seat belt. Engage the parking brake. Pull the seat bar all the way down. Start the engine. Operate each foot pedal to check both the lift and tilt functions. Raise the lift arms until the bucket is about 2 feet (600 mm) off the ground.

Raise the seat bar. Try to move each foot pedal. Pedals must be firmly locked in neutral position. There must be no motion of the lift arms or tilt (bucket) when the pedals are pushed.

Pull the seat bar down, lower the lift arms. Operate the lift pedals. While the lift arms are going up, raise the seat bar and the lift arms should stop.

Lower the seat bar, lower the lift arms and place the bucket flat on the ground. Stop the engine. Raise the seat bar and operate the foot pedals to be sure that the pedals are firmly locked in the neutral position. Unbuckle the seat belt.

Seat Bar Maintenance (Foot Controls)

See the *SERVICE SCHEDULE* in this manual and on the loader for correct service interval.

Clean any debris or dirt from the moving parts [A] & [B]. Inspect the linkage bolts and nuts for tightness. The correct torque is 25–28 ft.-lbs. (34–38 Nm).

If the seat bar system does not function correctly, check for free movement of each linkage part. Check for excessive wear. Adjust pedal control linkage. Replace parts that are worn or damaged. Use only genuine Melroe replacement parts.

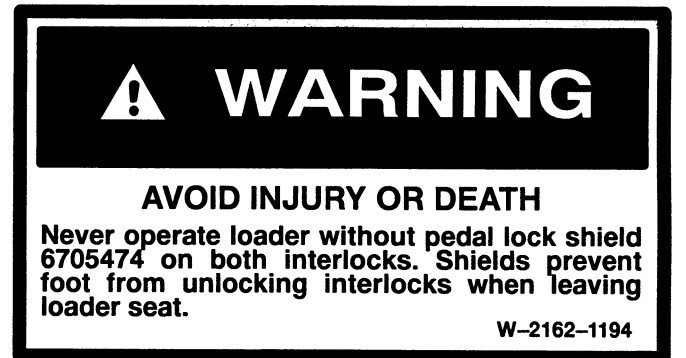
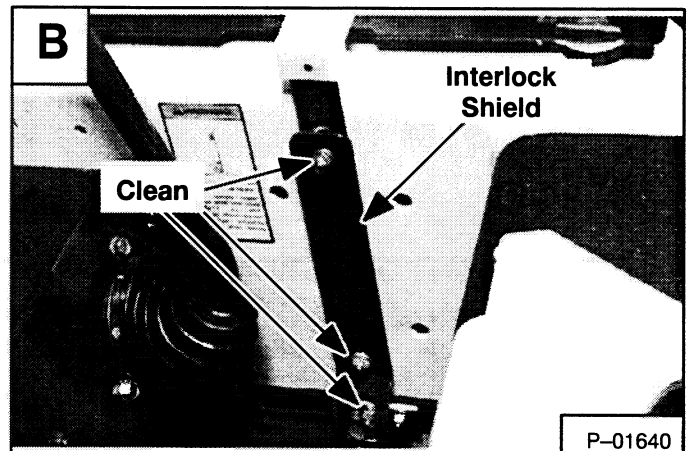
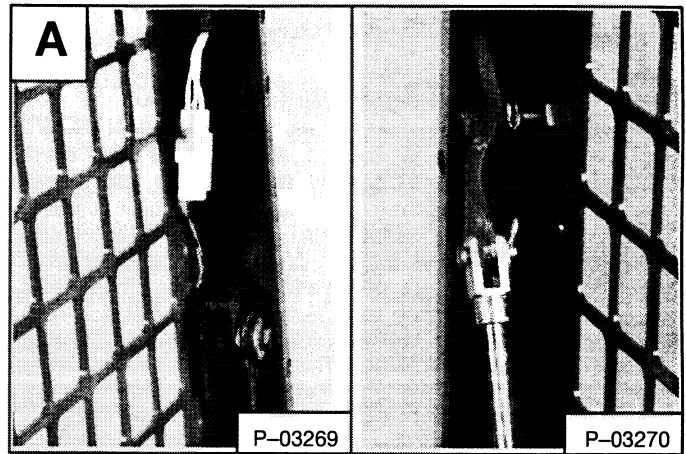



Suggest:

If the above button click is invalid.

Please download this document

first, and then click the above link

to download the complete manual.

Thank you so much for reading

SEAT BAR RESTRAINT SYSTEM

Description (Hand Controls)

The seat bar restraint system has a pivoting seat bar with arm rests and has spring loaded interlocks for the lift and tilt hand controls. The operator controls the use of the seat bar. The seat bar in the down position helps to keep the operator in the seat. The interlocks require the operator to lower the seat bar in order to operate the hand controls. When the seat bar is up, the lift and tilt controls are locked when returned to the neutral position.



Seat Bar Inspection (Hand Controls)

Sit in the seat and fasten the seat belt. Engage the parking brake. Pull the seat bar all the way down. Start the engine. Operate each hand control to check both the lift and tilt functions. Raise the lift arms until the bucket is about 2 feet (600 mm) off the ground.

Raise the seat bar. Try to move each hand control. The controls must be firmly locked in neutral position. There must be no motion of the lift arms or tilt (bucket) when the controls are pushed.

Pull the seat bar down, lower the lift arms. Operate the lift control. While the lift arms are going up, raise the seat bar and the lift arms should stop.

Lower the seat bar, lower the lift arms and place the bucket flat on the ground. Stop the engine. Raise the seat bar and operate the hand controls to be sure that they are firmly locked in the neutral position. Unbuckle the seat belt.

Seat Bar Maintenance (Hand Controls)

See the *SERVICE SCHEDULE* in this manual and on the loader for correct service interval.

Clean any debris or dirt from the moving parts [A] & [B]. Inspect the linkage bolts and nuts for tightness. The correct torque is 25–28 ft.-lbs. (34–38 Nm).

If the seat bar system does not function correctly, check for free movement of each linkage part. Check for excessive wear. Adjust hand control linkage. Replace parts that are worn or damaged. Use only genuine Melroe replacement parts.

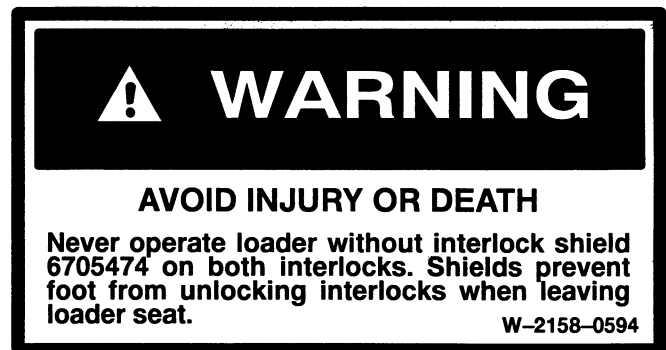
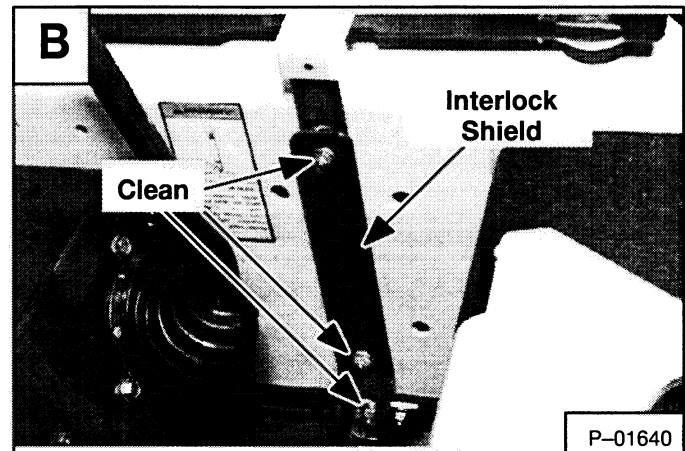
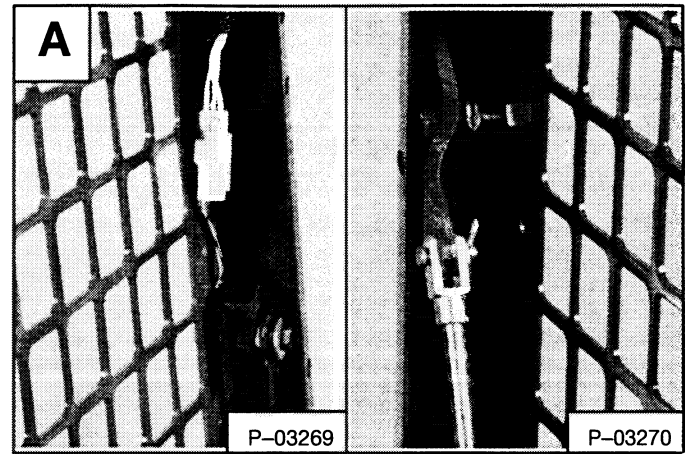

<https://www.ebooklibonline.com>

Hello dear friend!

Thank you very much for reading.

Enter the link into your browser.

The full manual is available for immediate download.

<https://www.ebooklibonline.com>