

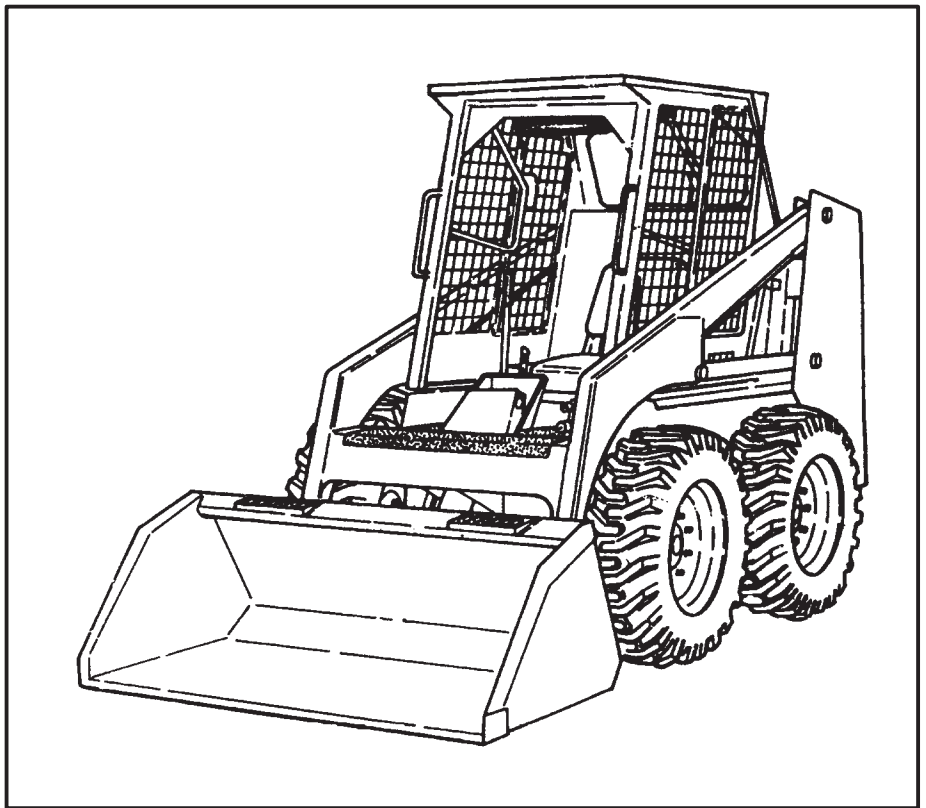
6  
4  
1

6  
4  
2

6  
4  
3



# Service Manual



**MELROE**  
**INGERSOLL-RAND**

6566135(10-86)

Printed in U.S.A.



© Melroe Company 1996

# MAINTENANCE SAFETY



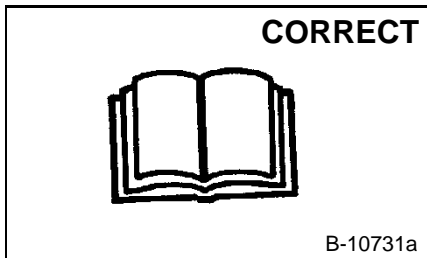
## WARNING

Instructions are necessary before operating or servicing machine. Read and understand the Operation & Maintenance Manual, Operator's Handbook and signs (decals) on machine. Follow warnings and instructions in the manuals when making repairs, adjustments or servicing. Check for correct function after adjustments, repairs or service. Untrained operators and failure to follow instructions can cause injury or death.

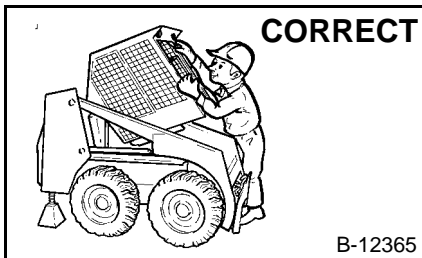
W-2003-0903



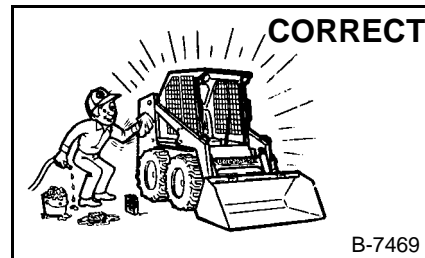
**Safety Alert Symbol:** This symbol with a warning statement, means: "Warning, be alert! Your safety is involved!" Carefully read the message that follows.



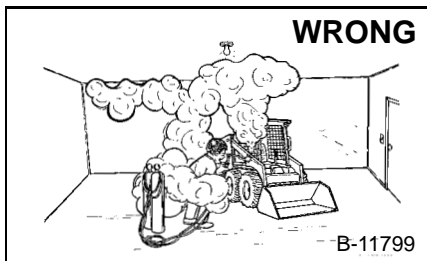
Never service the Bobcat Skid-Steer Loader without instructions.



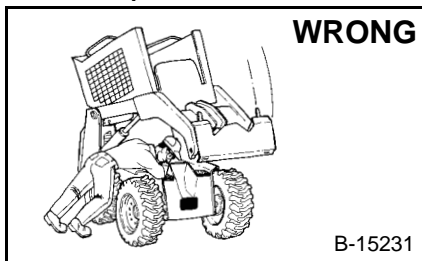
Use the correct procedure to lift or lower operator cab.



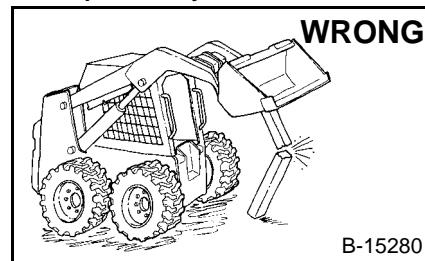
Cleaning and maintenance are required daily.



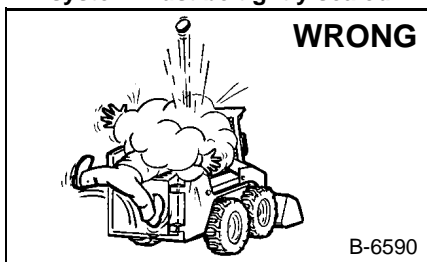
- Have good ventilation when welding or grinding painted parts.
- Wear dust mask when grinding painted parts. Toxic dust and gas can be produced.
- Avoid exhaust fume leaks which can kill without warning. Exhaust system must be tightly sealed.



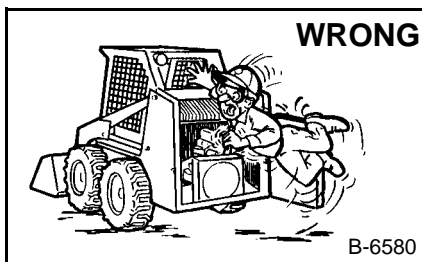
Disconnecting or loosening any hydraulic tubeline, hose, fitting, component or a part failure can cause lift arms to drop. Do not go under lift arms when raised unless supported by an approved lift arm support device. Replace it if damaged.



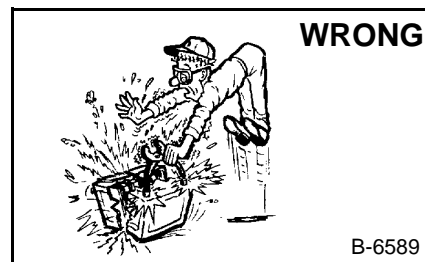
- Never work on loader with lift arms up unless lift arms are held by an approved lift arm support device. Replace if damaged.
- Never modify equipment or add attachments not approved by Bobcat Company.



- Stop, cool and clean engine of flammable materials before checking fluids.
- Never service or adjust loader with the engine running unless instructed to do so in the manual.
- Avoid contact with leaking hydraulic fluid or diesel fuel under pressure. It can penetrate the skin or eyes.
- Never fill fuel tank with engine running, while smoking or when near open flame.



- Keep body, jewelry and clothing away from moving parts, electrical contact, hot parts and exhaust.
- Wear eye protection to guard from battery acid, compressed springs, fluids under pressure and flying debris when engines are running or tools are used. Use eye protection approved for type of welding.
- Keep rear door closed except for service. Close and latch door before operating the loader.



- Lead-acid batteries produce flammable and explosive gases.
- Keep arcs, sparks, flames and lighted tobacco away from batteries.
- Batteries contain acid which burns eyes or skin on contact. Wear protective clothing. If acid contacts body, flush well with water. For eye contact flush well and get immediate medical attention.

Maintenance procedures which are given in the Operation & Maintenance Manual can be performed by the owner/operator without any specific technical training. Maintenance procedures which are **not** in the Operation & Maintenance Manual must be performed **ONLY BY QUALIFIED BOBCAT SERVICE PERSONNEL**. Always use genuine Bobcat replacement parts. The Service Safety Training Course is available from your Bobcat dealer.

## SAFETY INSTRUCTIONS

### SAFETY IS YOUR RESPONSIBILITY

We care about your safety.

The Bobcat loader is designed to give maximum operator safety; but no machine design can prevent operator error or carelessness.

### BEFORE YOU WORK ON THE BOBCAT LOADER

This SERVICE MANUAL was written to give the serviceman (mechanic) instructions for safe adjustments and/or repairs of the Bobcat loader.

Read the complete sequence in the paragraph (Example: 4-3.1 Axle and Bearing Removal Steps 1 thru 14) so you know the complete removal procedure before the work is actually started.

Always use jackstands and lift arm stops so you have a safe working area around the Bobcat loader.



B-03926



**For your safety, warnings are on the loader and in the manual. Failure to follow these warnings can cause injury or death.**



**This notice shows important procedures which must be followed to prevent damage to the loader.**

**<https://www.ebooklibonline.com>**

Hello dear friend!

Thank you very much for reading.

Enter the link into your browser.

The full manual is available for immediate download.

**<https://www.ebooklibonline.com>**

## FORWARD

This Service Manual gives the instructions for correct servicing, adjustment and overhauling of the Bobcat loader Hydraulic/Hydrostatic System, Drive System, Main Frame, Electrical System and Engine Service.

Make reference to the Operator's Manual for operating instructions (Starting, Daily Checks, Loader Operation, etc.).

A general inspection of the following items must be made when the Bobcat loader has had service or repair.

1. Check hydraulic/hydrostatic fluid level, engine oil level and fuel supply.
2. Inspect for any sign of fuel, oil or hydraulic fluid leaks.
3. Lubricate the loader.
4. Check the condition of the battery(ies) and the cables.
5. Inspect the air cleaner system for damage or leaks.
6. Check the warning lights to see if they light.
7. Check tires for wear and pressure.
8. Check the Bob-Tach for wear and see if the wedges are damaged.
9. Check the safety items for condition (Operator Guard, Seat Belt, Seat Bar, Safety Signs (Decals), Safety Treads, etc.).
10. Make an inspection for loose or broken parts or connections.
11. Operate the loader, checking all functions.

Check the above items. If any are in need of repair or adjustment, contact the owner.

## CONTENTS

	Page Number
ALPHABETICAL INDEX .....	9
DRIVE SYSTEM .....	4
ELECTRICAL SYSTEM .....	6
ENGINE SERVICE .....	7
HYDRAULIC SYSTEM .....	2
HYDROSTATIC SYSTEM .....	3
MAIN FRAME .....	5
PREVENTIVE MAINTENANCE .....	1
TECHNICAL DATA .....	8

**PREVENTIVE  
MAINTENANCE**

**HYDRAULIC  
SYSTEM**

**HYDROSTATIC  
DRIVE SYSTEM**

**DRIVE  
SYSTEM**

**MAIN  
FRAME**

**ELECTRICAL  
SYSTEM**

**ENGINE  
SERVICE**

**TECHNICAL  
DATA**

**ALPHABETICAL  
INDEX**

## PREVENTIVE MAINTENANCE

## PREVENTIVE MAINTENANCE

	Paragraph Number	Page Number
AUXILIARY CONTROL LOCKBOLT .....	1-15	1-20
BOB-TACH .....	1-13	1-19
DRIVE BELTS .....	1-6	1-12
ELECTRICAL SYSTEM .....	1-7	1-13
ENGINE COOLING SYSTEMS .....	1-5	1-10
ENGINE SERVICE .....	1-3	1-4
FINAL DRIVE .....	1-9	1-17
FUEL SYSTEM .....	1-4	1-8
HYDRAULIC/HYDROSTATIC SYSTEM .....	1-8	1-15
INTRODUCTION .....	1-1	1-1
LIFT ARM STOP .....	1-16	1-20
LUBRICATION OF THE BOBCAT LOADER .....	1-11	1-18
OPERATOR GUARD .....	1-12	1-19
PIVOT PINS .....	1-14	1-20
SERVICE SCHEDULE .....	1-2	1-3
TIRE MAINTENANCE .....	1-10	1-17



### WARNING

Instructions are necessary before operating or servicing machine. Read Operation & Maintenance Manual, and signs (decals) on machine. Follow warnings and instructions in the manuals when making repairs, adjustments or servicing. Check for correct function after adjustments, repairs or service. Failure to follow instructions can cause injury or death.

W-2144-0189

# 1-PREVENTIVE MAINTENANCE

## 1-1 INTRODUCTION

The Preventive Maintenance Section of this Service Manual gives general maintenance procedures for the Bobcat loader. The other sections of the Service Manual will give the detailed description needed for disassembly and assembly and when replacement parts are needed.

### 1-1.1 Serial Number Identification

It is important to make correct reference to the Serial Number of the Bobcat loader and/or engine when making repairs or ordering parts. It is possible that the present loaders do not use all the same parts as the earlier loaders. It is possible that different procedures are used for service repair.

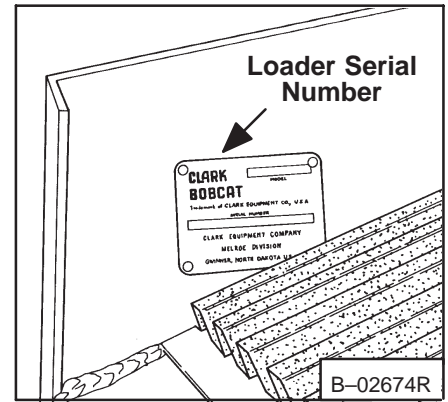


Fig. 1-1 Loader Serial Number

### 1-1.2 Loader Serial Number

The Bobcat loader serial number plate location is on the inside of the left upright, above the grill (Fig. 1-1).

Explanation of the Serial Number:

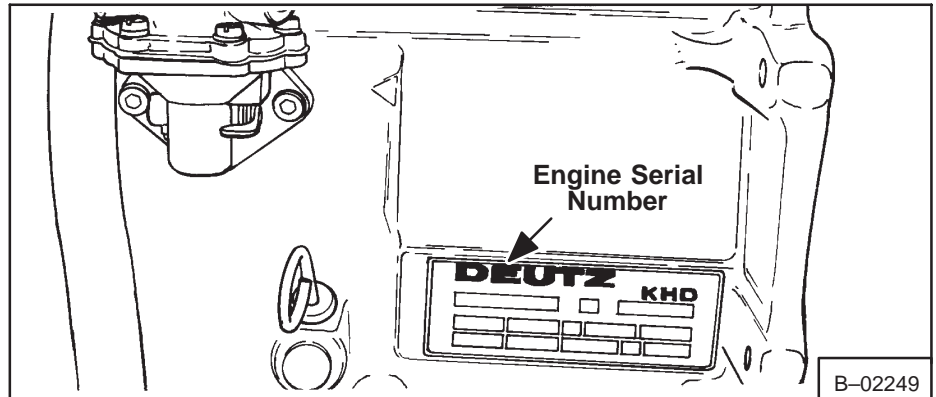
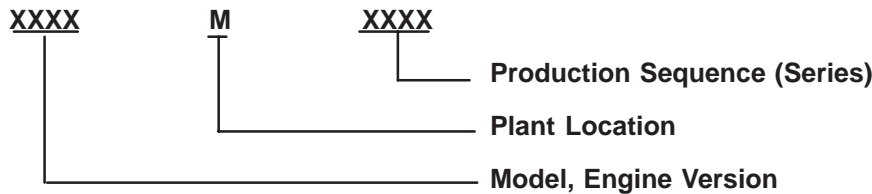


Fig. 1-2 (641) Engine Serial Number

### 1-1.3 Engine Serial Number

**641 Deutz:** (Fig. 1-2) The engine serial number location is on the right side of the cylinder block. Use all the numbers when ordering parts for this engine.

**642 Ford:** (Fig. 1-3) The engine serial number location is on the right side of the valve cover. Use all the numbers when ordering parts for this engine.

**643 Kubota:** (Fig. 1-4) The engine serial number location is on the left side above the speed control arm. Use all the numbers when ordering parts for this engine.

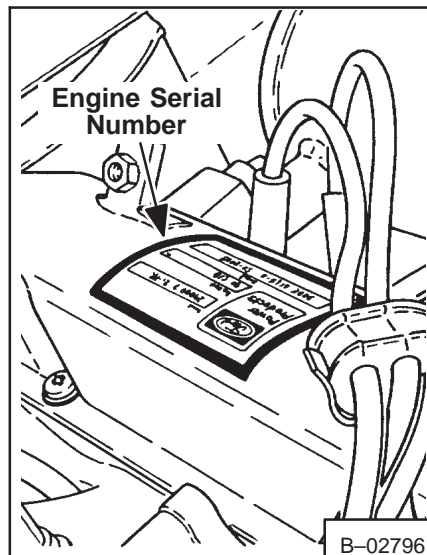


Fig. 1-3 (642) Engine Serial Number

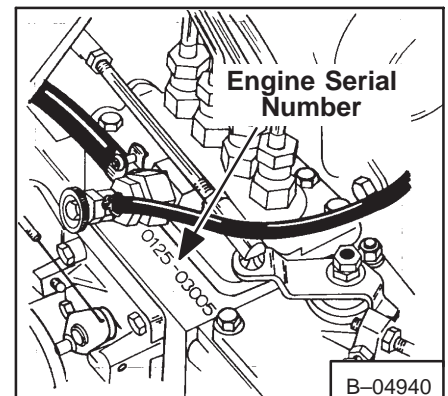


Fig. 1-4 (643) Engine Serial Number

## 1-2 SERVICE SCHEDULE

Maintenance work must be done at regular intervals. Failure to do so will result in damage to the Bobcat loader or the engine. The *SERVICE SCHEDULE* is a guide for correct maintenance of the Bobcat loader. DO NOT change this service schedule unless the frequency of service is increased when the Bobcat loader is operated in very hot, cold, dusty or corrosive conditions.

SERVICE SCHEDULE				HOURS							
641	642	643	ITEM	SERVICE REQUIRED	8-10	50	100	250	300	500	1000
			Engine Air Cleaner	Clean dust cup. Check condition of system. Check condition indicator.							
			Engine Cooling System	Check coolant level. Add coolant when level is low. Remove debris from the radiator grill area.							
			Tires	Check air pressure & check for damage.							
			Wheel Nuts	Tighten nuts 70 ft.-lbs. (95 Nm) torque.							
			Engine Oil	Check & add oil as needed.							
			All Pivot Points	Add lubricant to all fittings.							
			Engine Cooling Inlet	Check rear door grill & blower inlets for restriction of air flow. Clean cooling fins & blower housing when necessary.							
			Indicators, etc.	Check for correct operation of all.							
			Operator Cab	Check condition of cab & fastening bolts.							
			Seat Belt & Seat Bar	Check condition of strap & buckle & replace if damaged. Check working condition of seat bar.							
			Hydraulic Fluid	Check & add recommended fluid as needed.							
			Safety Signs (Decals)	Check for damage decals or decals that are gone. Replace as needed.							
			Engine Oil & Filter	Change the oil & the filter.							
			Battery	Check water level & cables.							
			Hydraulic Tubes & Hoses	Check for damage or leaks. Replace as needed.							
			V-Belts	Check tension & make adjustments.							
			Crankcase Breather	Clean breather cap every oil change.							
			Bob-Tach	Check locking levers & wedges for condition & operation.							
			Brakes	Check operation & adjust as needed.							
			Chaincase Fluid	Check fluid level & add as needed.							
			Hydraulic Filter (10 Micron)	Replace the filter element (S/N 14999 & Below).							
			Engine Cylinder Head Bolts	Tighten to correct torque after first 100 hours & adjust the valves as needed.							
			Engine Air Cleaner	Check system for leaks. Replace element when condition indicator shows red.							
			Crankcase Breather	Remove the breather & clean.							
			Governor	Check oil level in the reservoir.							
			Main Frame Upright	Check the torque of the bolts that hold the transmission assembly to the upright.							
			Spark Arrestor Muffler	Remove the plug & clean the spark chamber.							
			Steering Lever Pivots	Grease pivot points.							
			Engine Cylinder Compression	Check compression. Repair as needed.							
			Engine Fuel Filter	Replace the filter element.							
			Universal Joint	Grease U-joint.							
			Starting Motor	Remove, clean & service as needed.							
			Engine Fuel Filter (Inline)	Replace the element.							
			40 Micron Filter, Bronze (if so equipped)	Replace the filter in port block.							
			Hydraulic/Hydrostatic Reservoir	Replace breather cap.							
			Engine Compression	The minimum compression reading must be at least 75% of maximum compression reading.							
			Chaincase	Replace fluid.							
			Hydraulic System	Replace the fluid and filter. Clean cap and vent.							

! **WARNING**

AVOID INJURY OR DEATH

Stop, cool and clean engine of flammable material. Never service or adjust loader with engine running unless instructed to do so in manual.

W-2061-0887

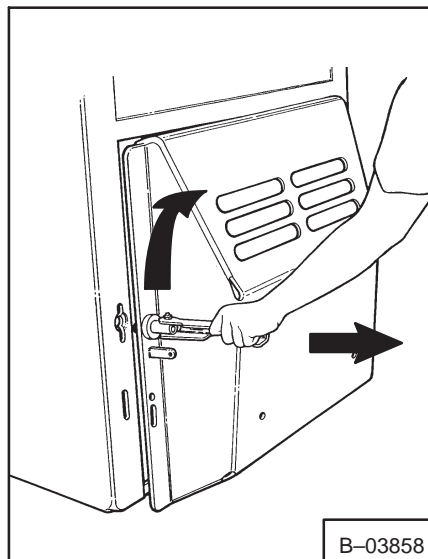


Fig. 1-7 Releasing Rear Door

### 1-3.1 Opening and Adjusting The Rear Door

Open the rear door to service the engine. Pull the door latch up and to the left to release the door latch (Fig. 1-7). The door can then be fully opened to get to the engine.

The door latch is adjusted by loosening the set screw. Turn the nut on the end of the latch pin (Fig. 1-8). The door must contact the machine at the bottom (Fig. 1-9) and the top with the lever in the position shown in figure 1-9. It will take approximately 50 lbs. of force to push the latch down. When the latch is adjusted correctly, tighten the set screw. The set screw must be aligned with the flat surface of the bolt.

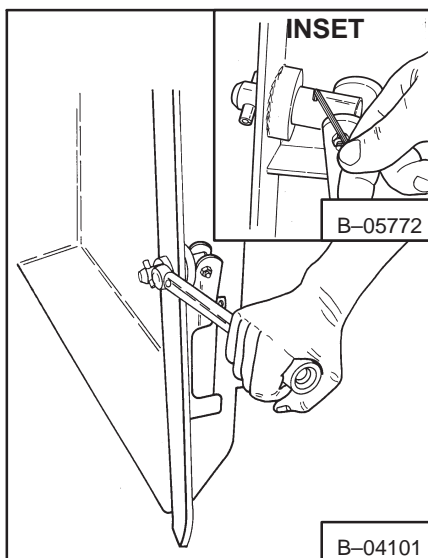


Fig. 1-8 Locking Nut

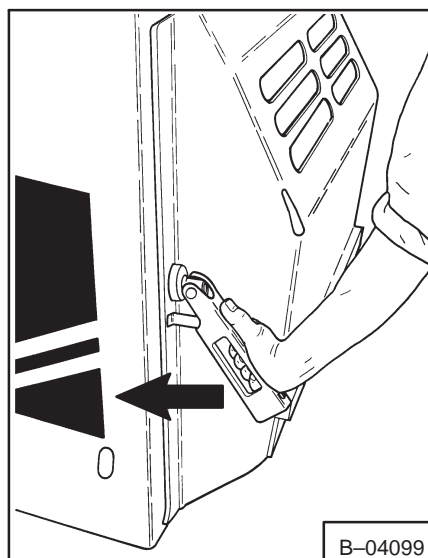


Fig. 1-9 Closing Door

! **WARNING**

Keep the rear door closed when operating the machine. Failure to do so could seriously injure a bystander.

W-2020-1285

### 1-3.2 Engine Lubrication System

To check the oil level, stop the engine and remove the dipstick from the engine (Fig. 1-10, 1-11, 1-12, Items 1).

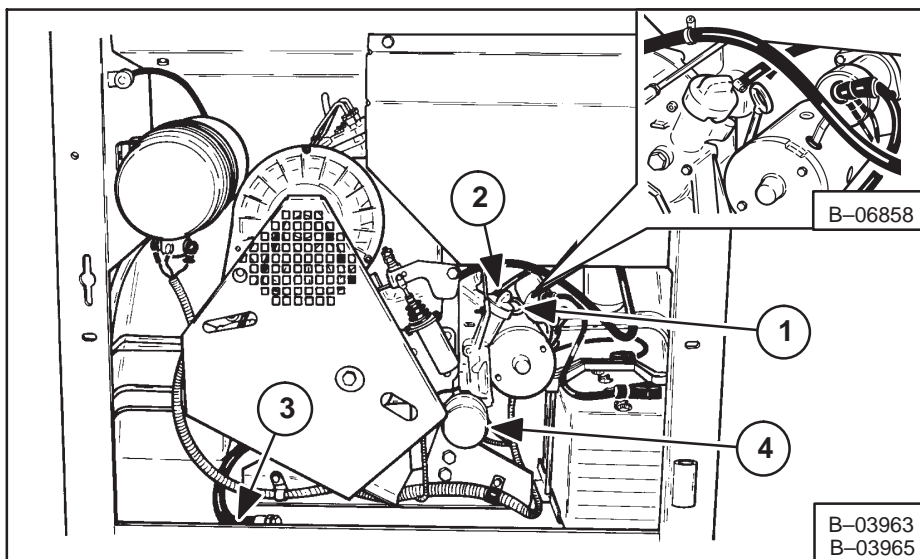


Fig. 1-10 Engine Servicing (641)

The oil level must be kept between the two marks on the dipstick.

Use a good quality motor oil that has the correct API Service Classification (See the Chart on page 1-6).

To add oil remove the fill cap (Fig. 1-10, 1-11, 1-12, Items 2)

**642 Loader Only:** Check the governor oil level every 100 hours of loader operation. Use the following procedure to check the oil level:

1. Remove the check plug (Fig. 1-12A, Item 1).

2. If oil flows, the level is correct.

3. If no oil flows, remove the fill plug (Fig. 1-12A, Item 2) and add SAE 10W-30 or 10W-40 oil until it flows from the check plug hole.

4. Install and tighten the check plug and the fill plug.

### 1-3.3 Replacement Of Engine Oil And Filter

Replace the engine oil and filter every 50 hours of loader operation.

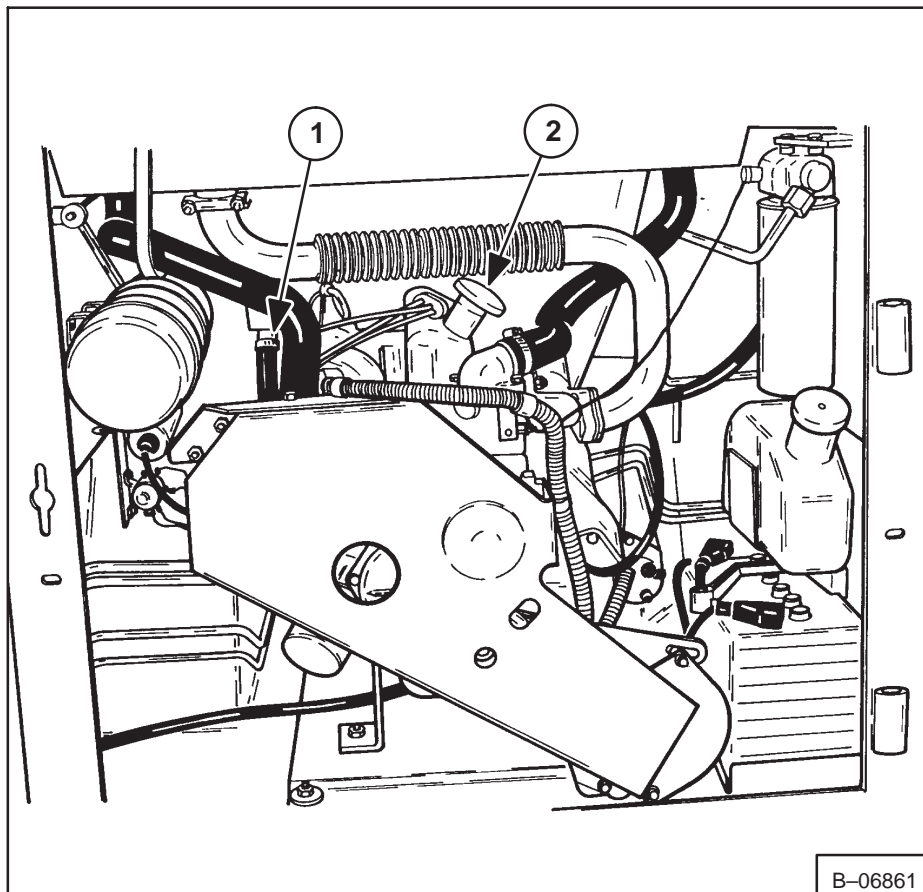


Fig. 1-11 Engine Servicing (642)

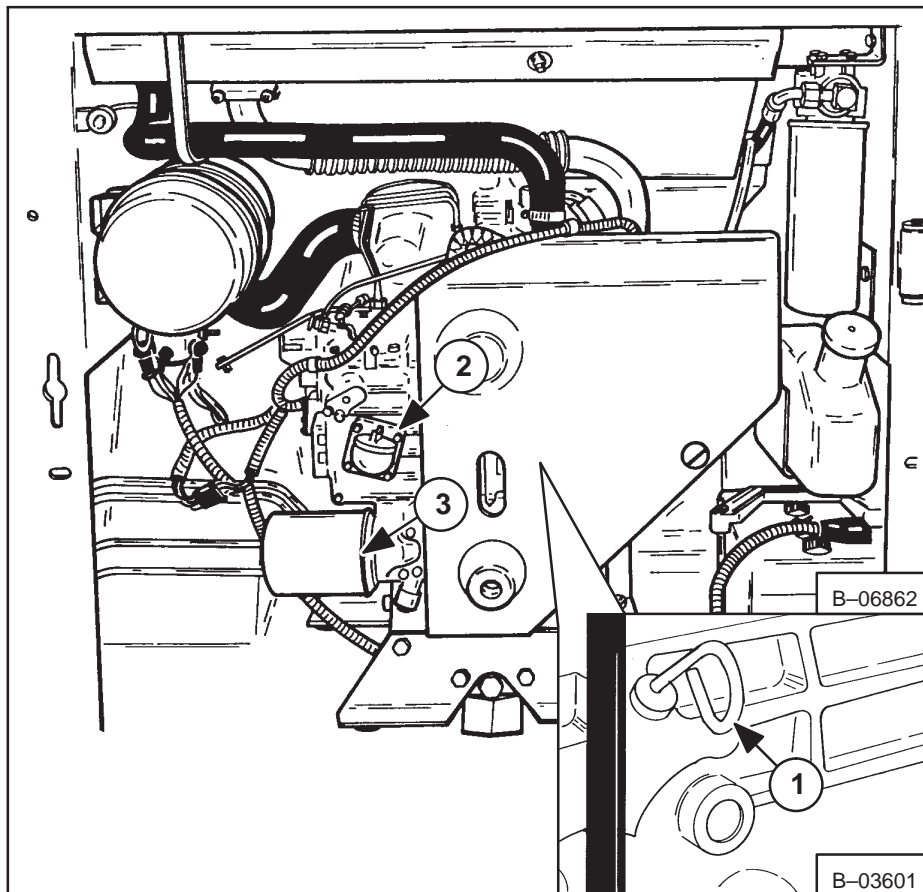
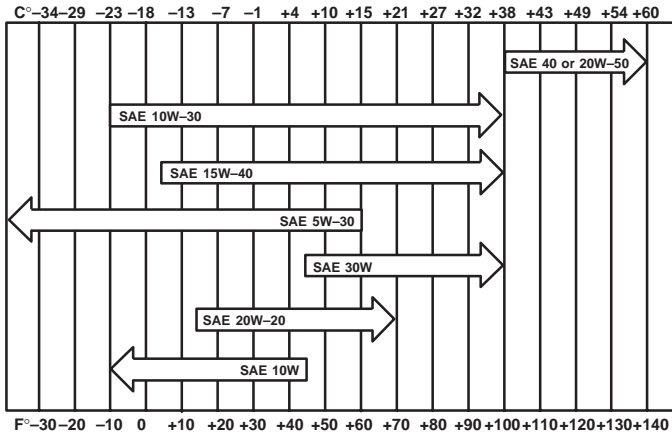
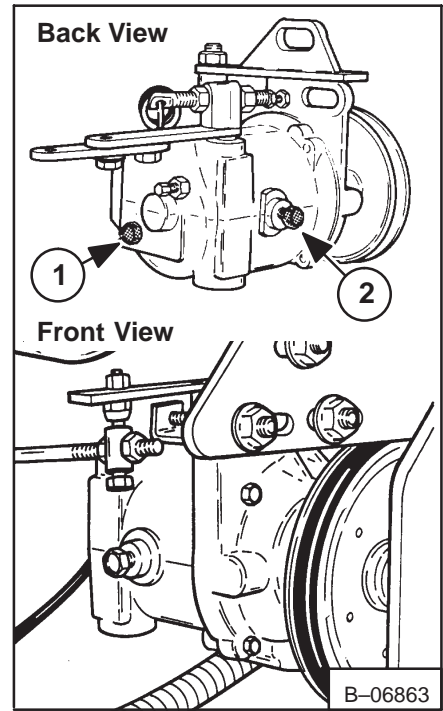


Fig. 1-12 Engine Servicing (643)

**RECOMMENDED SAE VISCOSITY NUMBER  
(LUBRICATION OILS FOR ENGINE CRANKCASE)**



**TEMPERATURE RANGE ANTICIPATED BEFORE NEXT OIL CHANGE  
(GASOLINE: USE API CLASSIFICATION SE OR SF)  
(DIESEL: USE API CLASSIFICATION CC OR CD)**

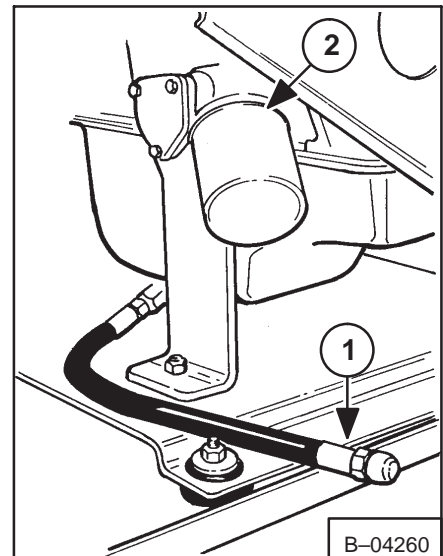


**Fig. 1-12A** Governor Oil Level Check

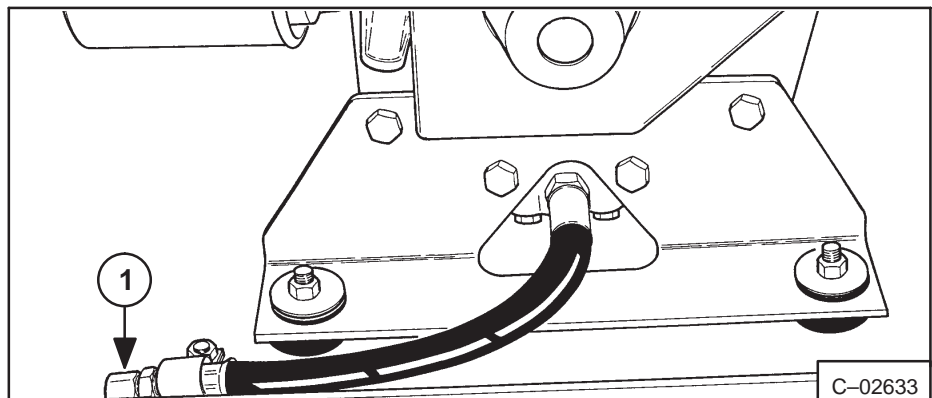
To replace engine oil and filter:

1. Operate the engine for approximately 15 minutes. Stop the engine.
2. Remove the oil plug (641, Fig. 1-10, Item 3) (642, Fig. 1-13, Item 1) (643, Fig. 1-14, Item 1).
3. Remove the oil filter (641, Fig. 1-10, Item 4) (642, Fig. 1-13, Item 2) (643, Fig. 1-12, Item 3).
4. Clean the filter housing surface. Put clean oil on the gasket of the new filter. Install the filter and tighten the filter hand tight.
5. Install the oil plug. Remove the oil filler cap (641, Fig. 1-19, Item 2) (642, Fig. 1-11, Item 2) (643, Fig. 1-12, Item 3).
6. Put in the correct oil (See the chart above). Put in the correct amount of oil (641, See Paragraph 8A-1.8, Page 8A-2) (642, See Paragraph 8B-1.8, Page 8B-2) (643, See Paragraph 8C-1.7, Page 8C-2).
7. Start the engine and let it run for 5 minutes. Stop the engine. Check for leaks at the filter. Check the oil level and add oil until the oil level is at the top mark on the dipstick.

**NOTE: DO NOT over-fill the crankcase with oil.**



**Fig. 1-13** Oil Plug (642)



**Fig. 1-14** Oil Plug (643)

### 1-3.4 Air Cleaner Service

It is important to service the air cleaner system at regular intervals for good engine performance and long service life.

Do not replace the filter element unless the red ring shows in the condition indicator (641 & 643, Fig. 1-15, Item 1; and 642, Fig. 1-16, Item 1).

The air cleaner system must be clean and must not be damaged for good engine performance and long service life.

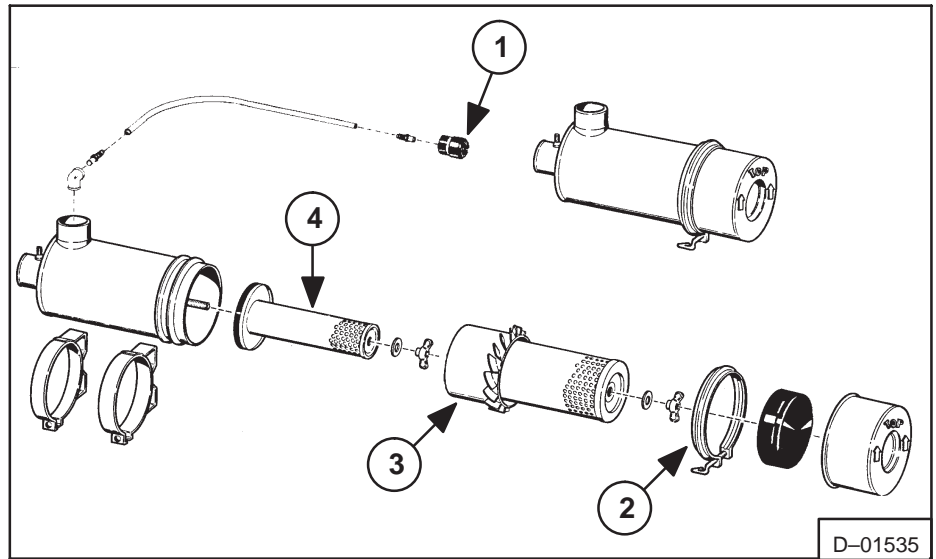


Fig. 1-15 Air Cleaner Service (641, 643)

Service the 641 and 643 air cleaners as follows:

1. Loosen the clamp on the dust cup (Fig. 1-15, Item 2). Remove the dust cup and the element.
2. Clean the inside of the filter housing so the element has a smooth surface to contact the seal (Fig. 1-15, Item 3).
3. Install the outer element.

**NOTE: Replace the inner element (Fig. 1-15, Item 4) approximately every third time unless the red ring still shows in the condition indicator after replacing the outer element.**

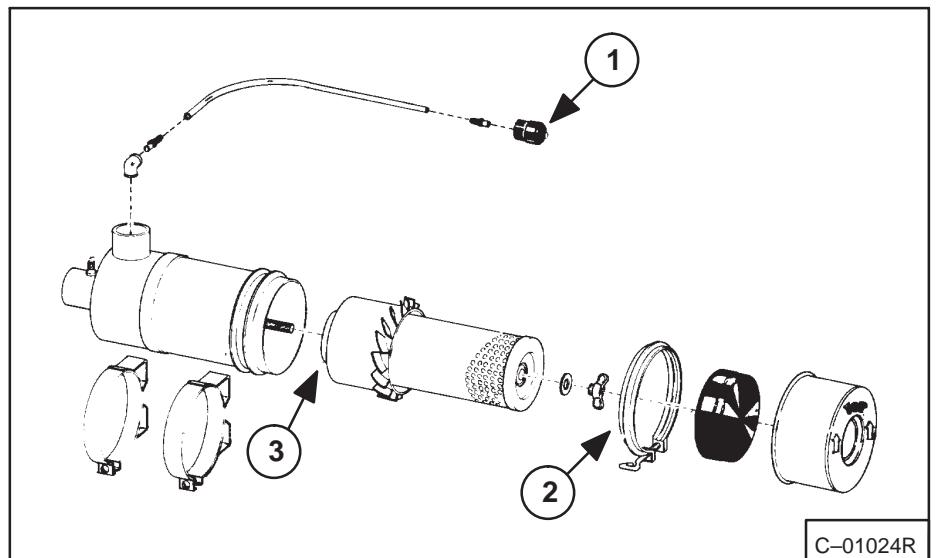


Fig. 1-16 Air Cleaner Service (642)

4. Install the dust cup with the arrows on the bottom of the cup up and tighten the clamp.
5. Push the button on the condition indicator to remove the red ring.
6. Check that the hoses and the clamps are tight.

Service the 642 air cleaner as follows:

1. Loosen the clamp on the dust cup (Fig. 1-16, Item 2). Remove the dust cup and the element.
2. Clean the inside of the filter housing so the element has a smooth surface to contact the seal (Fig. 1-16, Item 3).

3. Install the new filter element.
4. Install the dust cup so the arrow on the bottom of the cup is up and tighten the clamp.
5. Push the button, at the condition indicator (Fig. 1-16, Item 1) to remove the red ring.
6. Check that the hoses and the clamps are tight.

#### 1-4 FUEL SYSTEM

##### (641 & 643)

Use number 2 diesel fuel in the engine. During very cold temperature conditions number 1 fuel is recommended.

##### (642)

Use only 90-94 octane leaded fuel in the engine.

##### (641, 642 & 643)



Remove the filler cap to service the fuel tank as follows (Fig. 1-17 & 1-18, Items 1):

1. Use a clean approved safety container to add fuel.
2. The key switch must be off and the engine must be cool.
3. Add fuel only in an area that has a free movement of air and no open flames or sparks. NO SMOKING (Fig. 1-19).
4. Use only clean fuel of the correct specifications.
5. Tighten the cap on the fuel tank (Fig. 1-17 & 1-18, Items 1).

#### 1-4.1 Fuel Filter (641)

The fuel filter is installed on the right upright in the engine compartment. To replace the element:

1. Close the fuel line shut off valve (Fig. 1-17, Item 2).

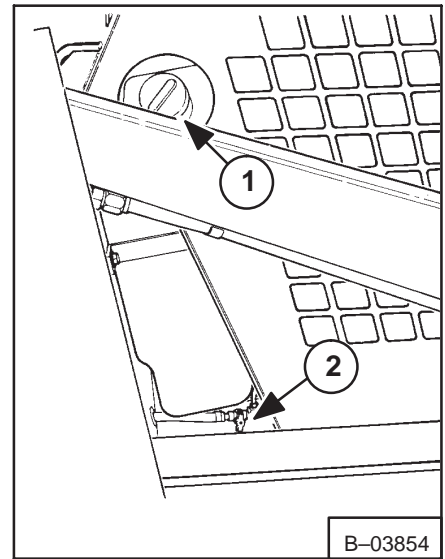


Fig. 1-17 Fuel Filling Location (641,643)

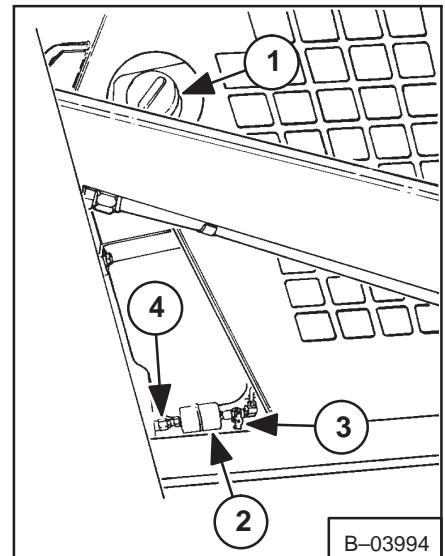


Fig. 1-18 Fuel Filling Location (642)

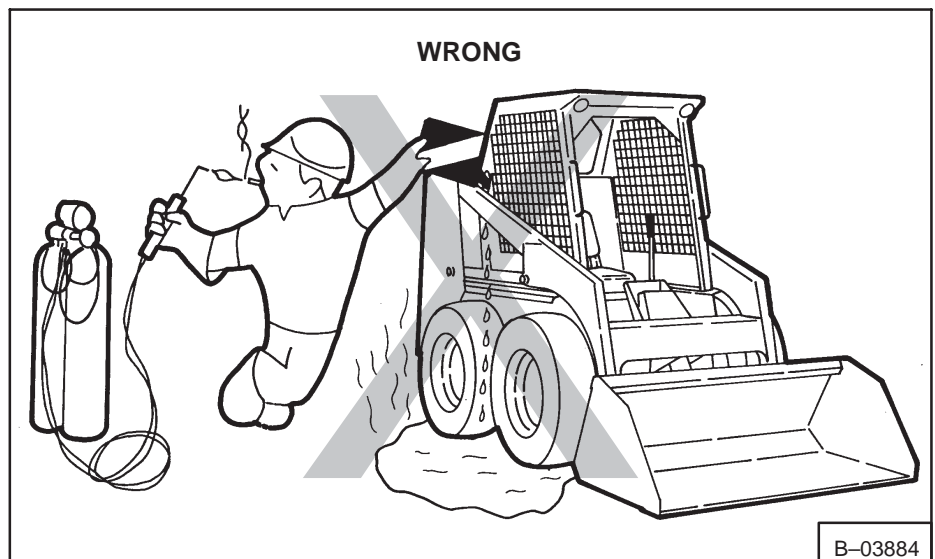


Fig. 1-19 Fuel Filling Procedure

2. Remove the filter by removing the bolt (Fig. 1–20, Item 1).
3. Put lubricant on the rubber gasket of the fuel filter.
4. After installing the new element, open the fuel valve and check for leaks.

#### 1–4.1 (Cont'd) Fuel Filter (642)

There is a fuel filter in the fuel line by the fuel shut-off valve (Fig. 1–18, Item 2).

Check or replace the fuel filter as follows:

1. Close the valve on the fuel line (Fig. 1–18, Item 3).
2. Loosen the nut and remove the tubeline (Fig. 1–18, Item 4).
3. Remove the filter element from the valve (turn the element clockwise).
4. Force air through the element in the direction of the arrow to check the filter.
5. Make sure the arrow is pointing in the direction of the carburetor when you install the element.
6. Install the element. Connect the tubeline and tighten the nut. Open the valve and check for leaks.

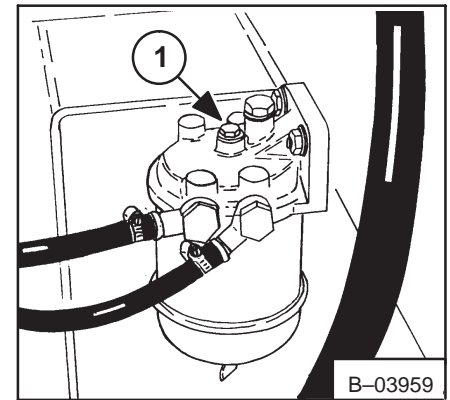


Fig. 1–20 Fuel Filter Service (641)

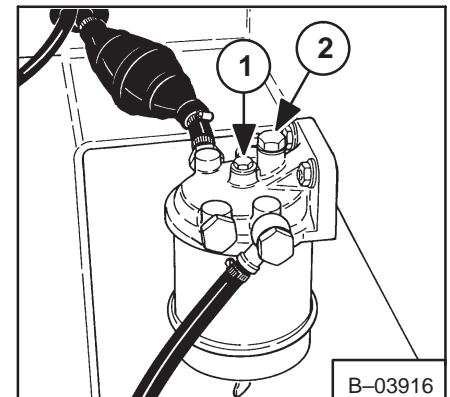


Fig. 1–21 Fuel Filter (643)

#### 1–4.1 (Cont'd) Fuel Filter (643)

The fuel filter on the 643 is installed on the right upright in the engine compartment. To replace the element:

1. Close the fuel line shut-off valve (Fig. 1–17, Item 2).
2. Remove the filter by removing the top screw (Fig. 1–21, Item 1).
3. Check the seal for damage and the surface where the seal makes contact. Repair as needed.
4. After installing the new element open the fuel shut-off valve. Loosen the plug on the top of the filter head (Fig. 1–21, Item 2). DO NOT tighten the plug until the fuel flows from around the plug. Then tighten the plug.
5. Check for leaks.

#### 1–4.2 Removing Air From The Fuel System (641)

After replacement of the fuel filter element or when the fuel tank has run out of fuel, air must be removed from the fuel system before running the engine.

To remove air:

1. Loosen the slotted plug on the injector pump (Fig. 1–22, Item 1) and activate the priming lever on the fuel pump until fuel is flowing from the loosened plug containing no air.

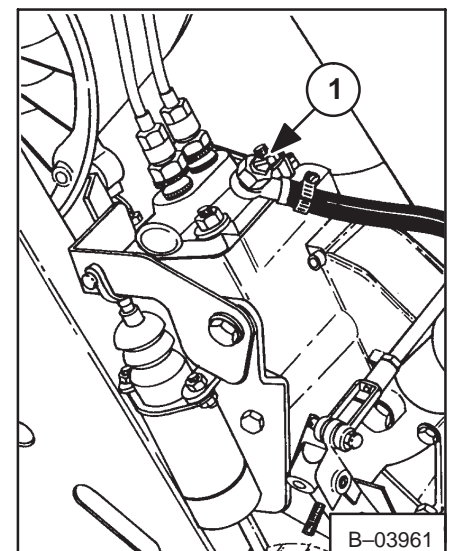


Fig. 1–22 Loosen The Slotted Plug (641)

- Loosen the pressure fitting at each injector (Fig. 1-23, Item 1) and turn the engine until fuel flows from the fittings containing no air. Tighten the fittings.

### 1-4.2 Removing Air From The Fuel System (643) (Cont'd)

After replacement of the fuel filter element, or when the fuel tank has run out of fuel, air must be removed from the fuel system before starting the engine.

To remove the air:

- Put the throttle at minimum RPM. Loosen the valve (Fig. 1-24, Item 1) on the top of the injector pump and squeeze the bulb several times (Fig. 1-21, Item 3). Turn the engine over with the starter. When the engine starts and runs smoothly, close the valve.

### 1-5 ENGINE COOLING SYSTEMS

#### (641)

The air cooled engine must have good air circulation to cool. Keep all shrouding installed except when cleaning the engine cooling fins.

Keep the rear door grill area free of debris and the shrouding free of leaks or dents. If the engine overheats an inspection of the cooling system must be made. Check for debris on the grill area and around the cylinder cooling fins. To clean the cooling fins, remove the blower housing cover (Fig. 1-25, Item 1). Use an air hose to remove debris from the cylinder head and blower fan (Fig. 1-25, Item 2).

#### (642, 643)

The cooling system has a coolant recovery tank. The location of the tank is on the right upright in the engine compartment (Fig. 1-26, Item 1). Remove the cap from the coolant recovery tank to check the coolant level. When the engine is cool, the coolant recovery tank must be 1/3 full. Add coolant to the coolant recovery tank when the coolant level is low.

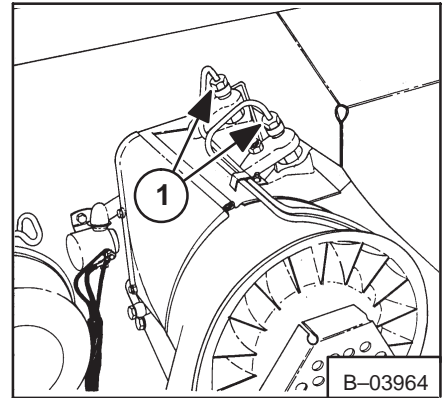


Fig. 1-23 Injector Lines (641)

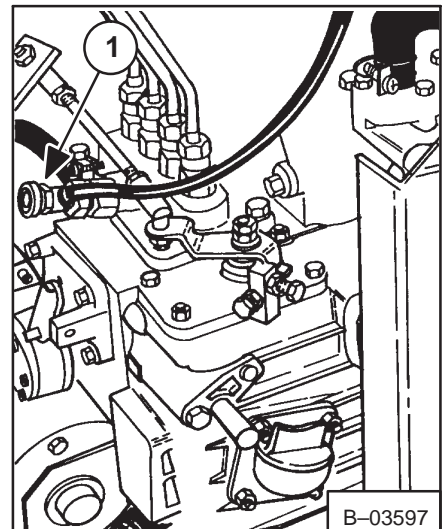


Fig. 1-24 Removing Air From Fuel System (643)

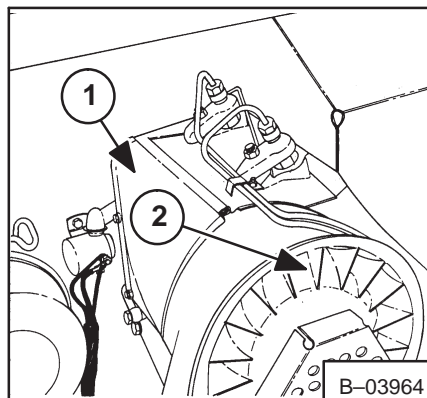


Fig. 1-25 Cleaning Cooling Fins (641)

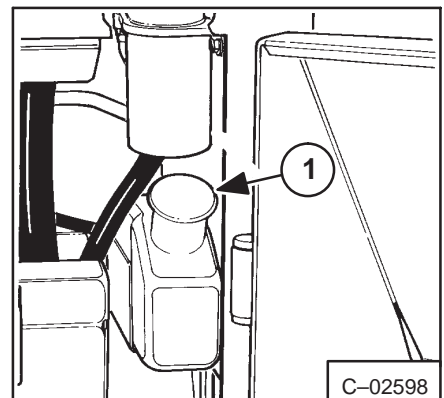


Fig. 1-26 Coolant Tank (642, 643)

## 1-5.1 Removing Coolant From The Cooling System

To remove coolant (642):

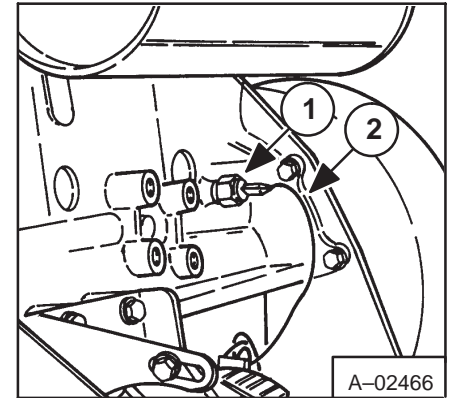


Fig. 1-27 Sender Switch (642)

1. Put a funnel under the temperature sender switch (Fig. 1-27, Item 1) to keep coolant from getting into the engine compartment.
2. Remove the grill (Fig. 1-28, Item 1).
3. Remove the radiator cap (Fig. 1-28, Item 2). The grill must be removed to do this.
4. Remove the wire (Fig. 1-27, Item 2) connected to the sender switch. Remove the sender switch (Fig. 1-27, Item 1).

To fill the cooling system (642):

1. Install the sender switch (Fig. 1-27, Item 1).
2. Connect the wire (Fig. 1-27, Item 2) to the sender switch.
3. Premix 50% water and 50% anti-freeze in a separate container (See Paragraph 8B-1.8, Page 8B-2 for capacity).
4. Fill the radiator with the mixed coolant and install the radiator cap.
5. Install the grill (Fig. 1-28, Item 1).
6. Fill the coolant recovery tank 1/3 full.

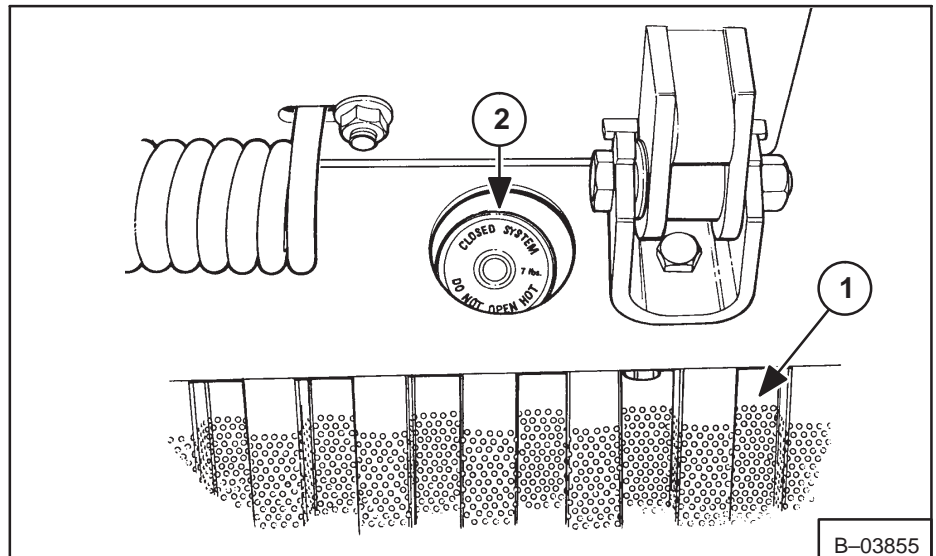


Fig. 1-28 Grill And Radiator Cap

**NOTE: Protect the cooling system from freezing temperatures and overheating by adding premixed 50/50 ethylene glycol and water to the system.**

To remove coolant from the cooling system (643):

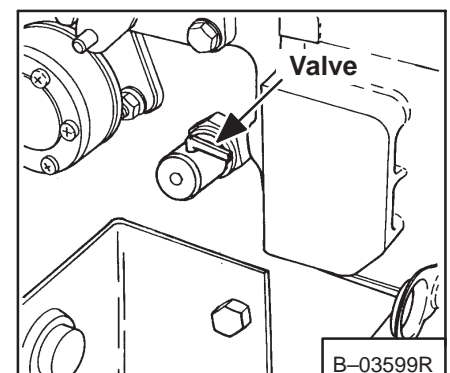


Fig. 1-29 Valve For Removing Coolant (643)

The valve to remove the coolant is on the left side of the engine block (Fig. 1-29).

Revised Dec. 83

1. Connect a hose to the valve or use a funnel to keep coolant from getting into the engine compartment.
2. Remove the grill (Fig. 1-28, Item 1).
3. Remove the radiator cap (Fig. 1-28, Item 2). The grill must be removed to do this.

Turn the valve so that the lever is toward the outlet of the valve.

To fill the cooling system (643):

1. Close the drain valve (Fig. 1-29).
2. Premix 50% water and 50% anti-freeze in separate container (See Paragraph 8C-1.7, Page 8C-2 for capacity).
3. Fill the radiator and install the radiator cap.
4. Install the grill (Fig. 1-28, Item 1).
5. Fill the coolant recovery tank 1/3 full.

**NOTE: Protect the cooling system from freezing temperatures and overheating by adding premixed 50/50 ethylene glycol and water to the system.**

## 1-6 DRIVE BELTS

To adjust the belt tension:

### (641)

1. Stop the engine.
2. Loosen the adjustment bolt and move the alternator to adjust tension at 0.500 inch (13 mm) (Fig. 1-30). Then tighten the adjustment bolt.

### (642)

1. Stop the engine.
2. Remove the belt shield (Fig. 1-31).
3. Loosen the bolts for adjustment of the governor (Fig. 1-32, Item 1). Use a bar and adjust belt tension to 0.500 inch (13 mm) movement at the middle of the belt with 20 lbs. (9,07 kg) pressure (Fig. 1-32). Tighten the bolts.
4. Loosen the bolts for alternator adjustment (Fig. 1-32, Items 2 & 3). Move the alternator until the belt has 0.250 inch of movement at the middle of the belt with 20 lbs. (9,07 kg) pressure. Tighten bolts.
5. Install the belt shield.

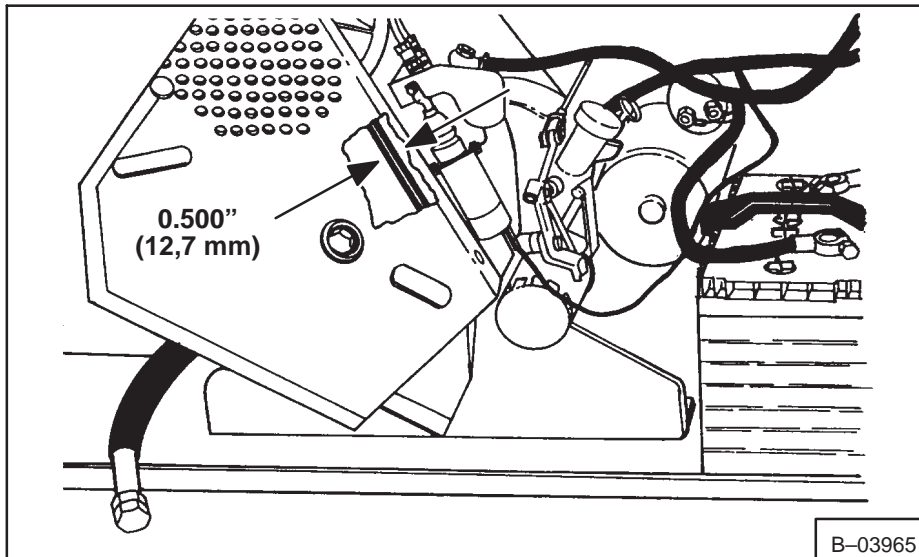


Fig. 1-30 Drive Belt Adjustment (641)

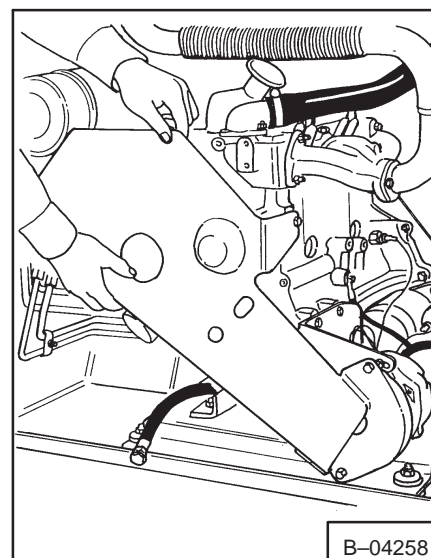


Fig. 1-31 Removing Belt Shield (642)

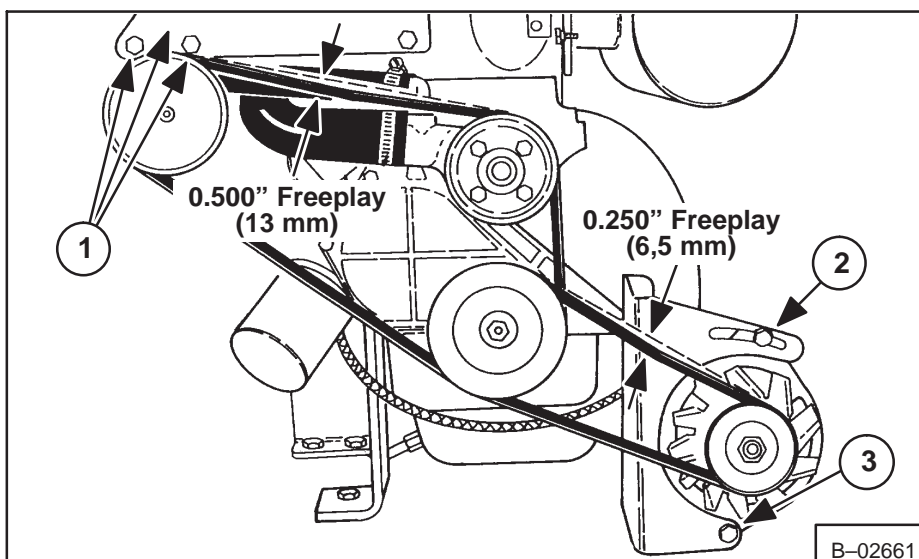


Fig. 1-32 Drive Belt Adjustment (642)

**NOTE:** When the governor has been moved, the rod to the throttle must be adjusted (See Paragraph 7B-2.4, Page 7B-3).

(643)

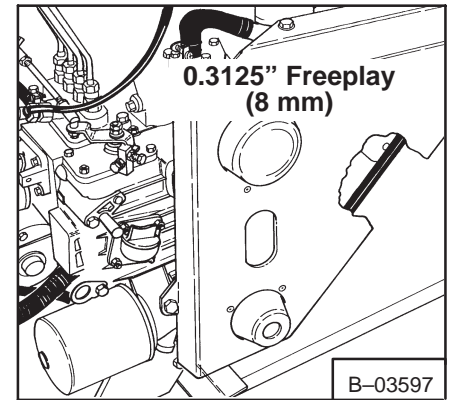
1. Stop the engine.
2. Loosen the adjustment bolt and move the alternator to adjust tension at 0.3125 inch (8 mm). Then tighten the adjustment bolt.

**1-7 ELECTRICAL SYSTEM SERVICE (See Section 6 (Electrical System) for more information.)**

1. Battery cables must be clean and tight. Remove any acid or corrosion from the battery and cables with a baking soda and water solution (Fig. 1-34). Cover the terminals with Clark Battery Saver to prevent corrosion. Install the covers on the terminals.
2. Two 25 ampere fuses are installed in the dash panel. If the fuses become damaged, replace them with the same type and size fuses.

### 1-7.1 Using An Extra Battery

If it is necessary to use an extra battery to start the engine. **BE CAREFUL!** This is a two person operation. There must be one person in the operator's seat and one person to connect and disconnect the battery cables.



**Fig. 1-33 Adjusting Drive Belt (643)**

**! WARNING**

Batteries contain acid which burns eyes and skin on contact. Wear goggles, protective clothing and rubber gloves to keep acid off body.

In case of acid contact, wash immediately with water. In case of eye contact get prompt medical attention and wash eye with clean, cool water for at least 15 minutes.

If electrolyte is taken internally drink large quantities of water or milk! **DO NOT** induce vomiting. Get prompt medical attention.

W-2065-1296

**! WARNING**

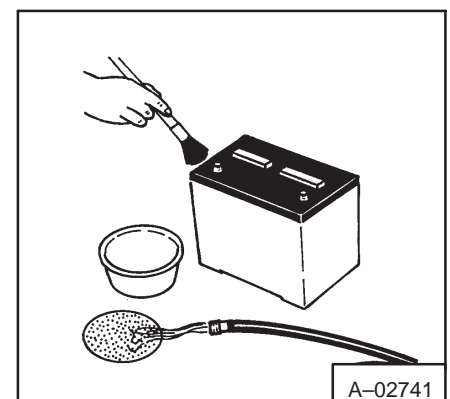
Keep arcs, sparks, flames and lighted tobacco away from batteries. When *jumping* from booster battery make final connection (negative) at engine frame.

Do not jump start or charge a frozen or damaged battery. Warm battery to 60°F. (16°C.) before connecting to a charger. Unplug charger before connecting or disconnecting cables to battery. Never lean over battery while boosting, testing or charging.

Battery gas can explode and cause serious injury.

W-2066-1296

1. The ignition must be in the off position.
2. Use an extra battery of the same voltage as the loader battery.
3. Battery terminals have identification marks. The positive terminal is marked (+) and the negative terminal is marked (-).
4. The negative terminal (-) of the battery must be connected to the engine.



**Fig. 1-34 Cleaning Battery Posts**



## WARNING

Keep arcs, sparks, flames and lighted tobacco away from batteries. When *jumping* from booster battery make final connection (negative) at engine frame.

Do not jump start or charge a frozen or damaged battery. Warm battery to 60°F. (16°C.) before connecting to a charger. Unplug charger before connecting or disconnecting cables to battery. Never lean over battery while boosting, testing or charging.

Battery gas can explode and cause serious injury.

W-2066-1296

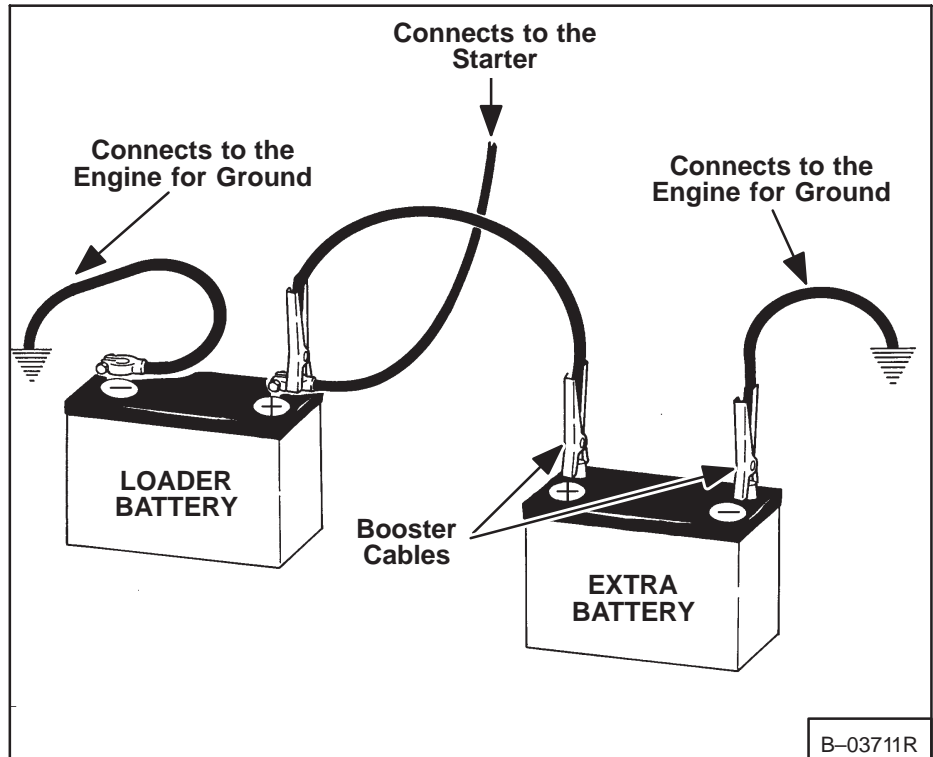


Fig. 1-35 Connecting Booster Cables

5. Connect the end of the first cable to the positive terminal (+) of the booster battery. Connect the other end of the same cable to the positive terminal (+) of the loader battery (Fig. 1-35).
6. Connect the end of the second cable to the negative terminal (-) of the booster battery. Connect the other end of the second cable to the engine. DO NOT connect the cable directly to the negative terminal (-) of the loader battery. Connecting the cable directly to the negative terminal (-) of the loader battery can cause a spark and destroy the battery and cause personal injury.
7. Keep the cables away from the fans and belts.

**NOTE:** The operator must be in the operator's seat and have the seat belt fastened.

8. Start the engine.
9. After the engine has started, remove the cable connected to the engine.
10. Then remove the cable from the loader battery post positive terminal (+).

## IMPORTANT

Damage to the alternator can occur if:

- Engine is operated with battery cables disconnected.
- Battery cables are connected when using a fast charger or when welding on the loader. (Remove both cables from the battery.)
- Extra battery cables (booster cables) are connected wrong.

I-2023-1285

### 1-7.2 Installing A New Battery

1. Remove the battery cables (Fig. 1-36). Remember the position of the positive terminal and the negative terminal so you can connect the cables correctly after the new battery is installed.

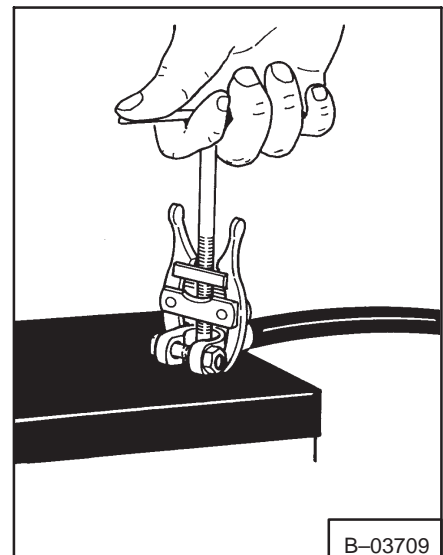


Fig. 1-36 Removing Cables

2. Remove the battery holddown clamp (Fig. 1–37, Item 1). Remove the battery from the engine compartment.
3. Clean the terminal posts (Fig. 1–38) of the new battery in the engine compartment. Install the holddown clamp.

**NOTE: DO NOT touch any metal with the battery terminals.**

4. Install and tighten the battery cables. Connect the ground (negative) cable last to prevent sparks.

### 1–8 HYDRAULIC/HYDROSTATIC SYSTEM (For more information see sections 2 and 3).

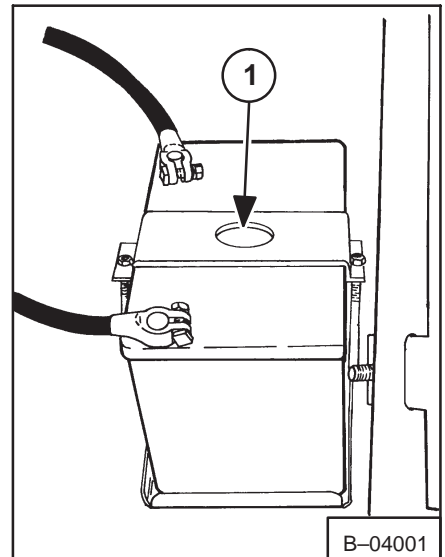
The hydraulic and hydrostatic systems use the same hydraulic oil reservoir.

The system has an engine driven vane pump that supplies hydraulic oil to the control valve and the lift and tilt cylinders.

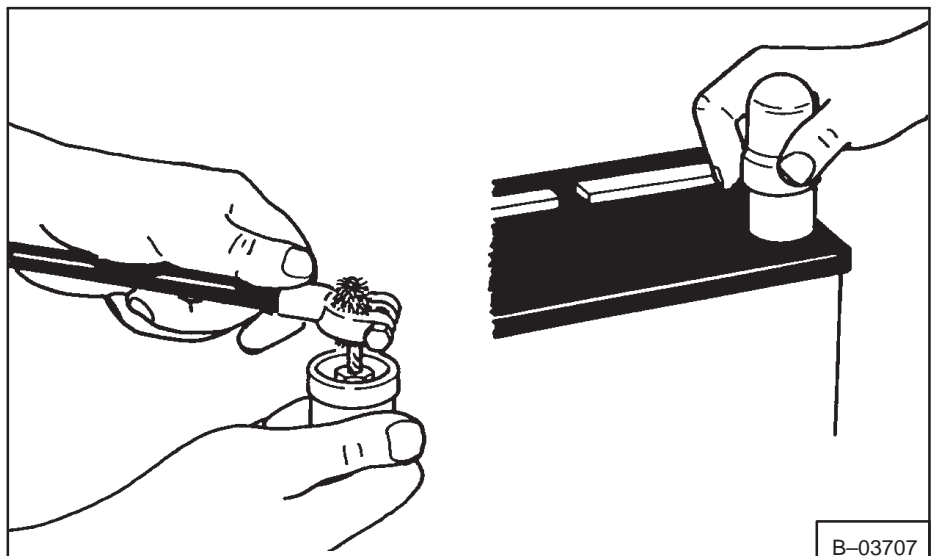
Oil also goes from the control valve to the hydrostatic transmission pumps to provide charge pressure and cooling.

A 10 micron filter is installed on the right side of the engine compartment (Fig. 1–39, Item 1). This filter is used to clean the oil for the hydrostatic transmission.

The location of the oil cooler is above the engine. The oil cooler is used for cooling the hydraulic oil before it returns to the vane pump.



**Fig. 1–37** Battery Holddown Clamp



**Fig. 1–38** Cleaning Battery Terminals

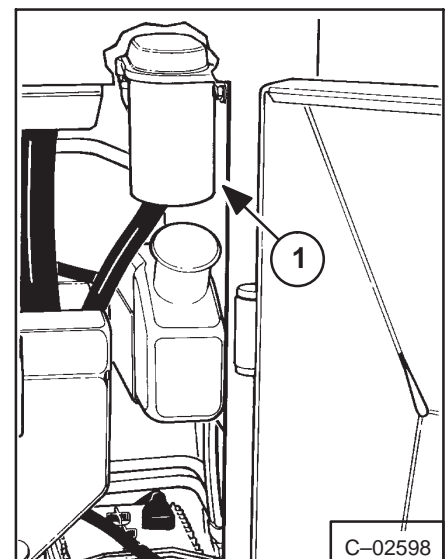
#### 1–8.1 HYDRAULIC/HYDROSTATIC OIL RESERVOIR

Use only recommended oil in the hydraulic system (Clark Bobcat fluid [P/N 6563328] or 10W–30, 10W–40 class SE motor oil [5W–30 at temperatures below 10°F. (–23°C.)])

#### 1–8.2 Checking And Adding Oil

To check the oil level in the hydraulic reservoir:

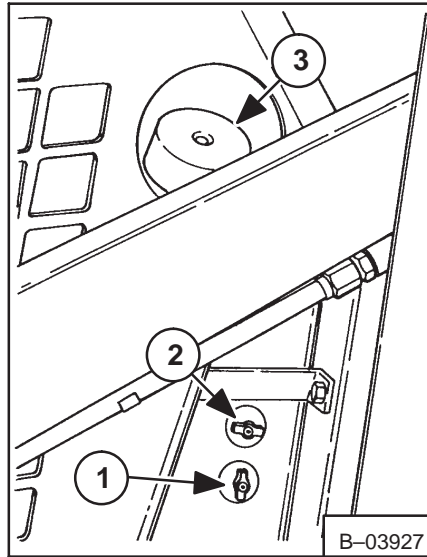
1. Put the loader on a level surface.



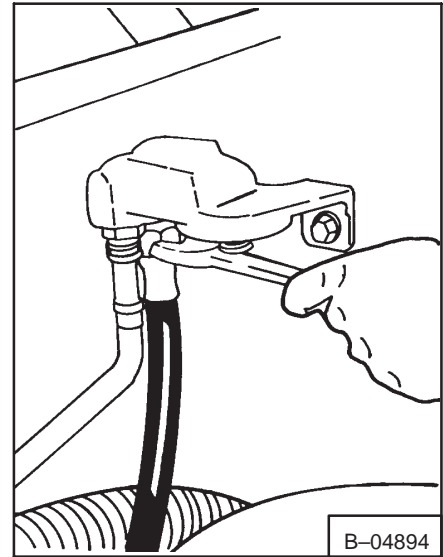
**Fig. 1–39** 10 Micron Filter

- Open the bottom check valve on the side of the reservoir (Fig. 1-40, Item 1). The oil level is good if the oil flows. If no oil flows, close the valve and proceed with step 3.

- Open the top check valve (Fig. 1-40, Item 2). Remove the fill cap from the reservoir (Fig. 1-40, Item 3). Add oil to the reservoir until oil flows at the top check valve. Close the valve and replace the fill cap.



**Fig. 1-40** Hydraulic Level Check

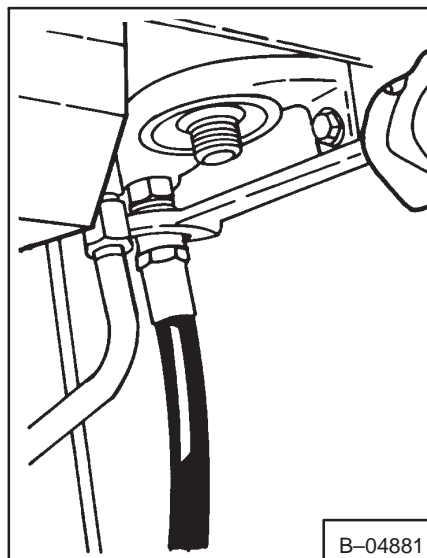


**Fig. 1-41** Removing Hose (641)

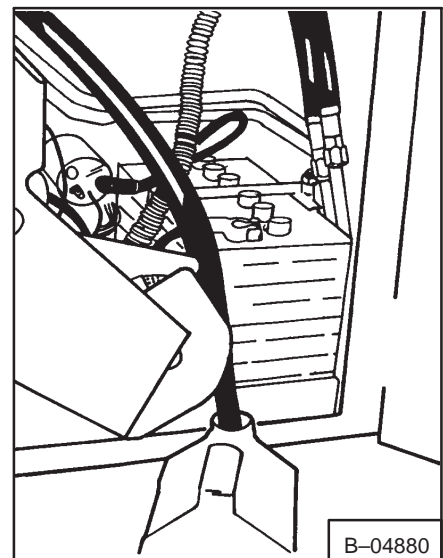
### 1-8.3 Removing Hydraulic Oil

Remove the oil from the hydraulic reservoir and replace it with new oil every 1000 hours of operation. Also replace the oil after it has become dirty and after any major repairs.

- Remove the hydraulic filter element. Remove the hose from the filter housing (641, Fig. 1-41) (642 & 643, Fig. 1-42). Let the oil flow into a container (Fig. 1-43).

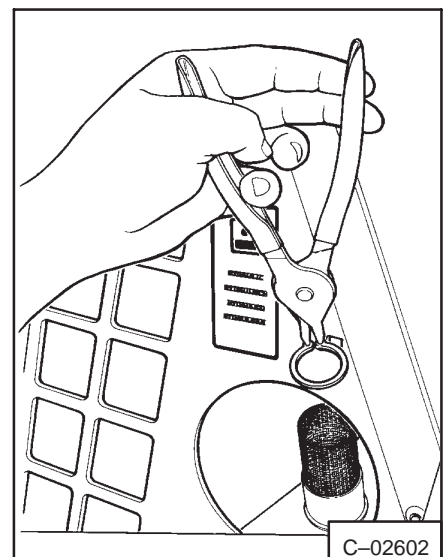


**Fig. 1-42** Removing Hose (642 & 643)



**Fig. 1-43** Draining Oil

- Connect the hose to the filter housing when the reservoir is empty. Install a new filter element.
- Remove the snap ring and remove the screen from the fill pipe (Fig. 1-44). Wash the screen in clean solvent and install it in the fill pipe.
- Open the top check valve (Fig. 1-40, Item 2). Remove the fill cap from the reservoir (Fig. 1-40, Item 3). Add oil to the reservoir until the oil flows at the top check valve (Refer to Technical Data for type of oil to use). Close the check valve and replace the fill cap. **DO NOT** fill above the top check plug level.



**Fig. 1-44** Snap Ring

### 1-8.4 Replacement Of The Hydraulic Filter

Replace the hydraulic filter every 100 hours of operation.

To replace the hydraulic filter element:

1. Remove the filter element (Fig. 1-45, Item 1). Let the oil flow into the container.
2. Clean the surface of the filter head where the filter element makes contact with the filter head.
3. Lubricate the rubber gasket on the filter element with oil.
4. Install the filter element. Tighten the filter by hand only.
5. Check for leaks after you operate the Bobcat loader.

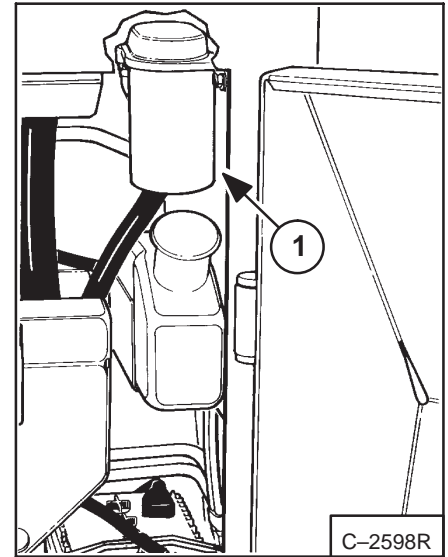


Fig. 1-45 Filter Element

### 1-9 FINAL DRIVE TRANSMISSION (CHAINCASE)

The chaincase contains the final drive sprocket and the chains. The chaincase is filled with the same type of oil as the hydraulic/hydrostatic system for chain lubrication. Refer to *TECHNICAL DATA* Section 8.

To check the chaincase oil level:

1. Put the Bobcat loader on a level surface.
2. Remove the plug at the front of the transmission housing (Fig. 1-46, Item 1).
3. Add oil through the check plug hole until the oil flows from the check plug hole. Install the plug.

See Paragraph 4-5.1, Page 4-13 to drain the chaincase.

### 1-10 TIRE MAINTENANCE

Check the tires regularly for wear, damage and correct pressure. See *TECHNICAL DATA* Section 8.

Check for loose wheel nuts. Correct torque is 65 ft.-lbs. (88 Nm) torque.

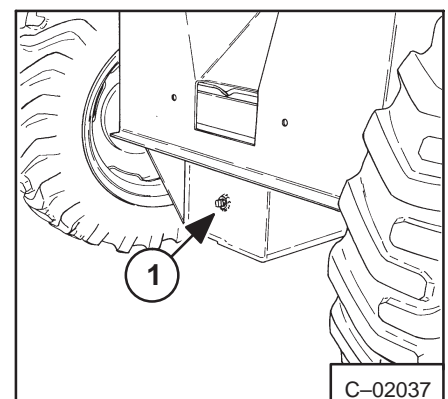


Fig. 1-46 Chaincase Plug

## 1-10.1 Tire Rotation

When two tires become worn more than the other two tires put the two worn tires on the same side. The front tires must be moved to the rear and the rear tires to the front to keep the tire wear even (Fig. 1-47).

When new tires are installed, always keep the tires of the same size on the same side of the Bobcat loader.

**NOTE:** Both wheels, on each side of the Bobcat loader are connected together and are driven at the same speed, so the tires must be the same size.

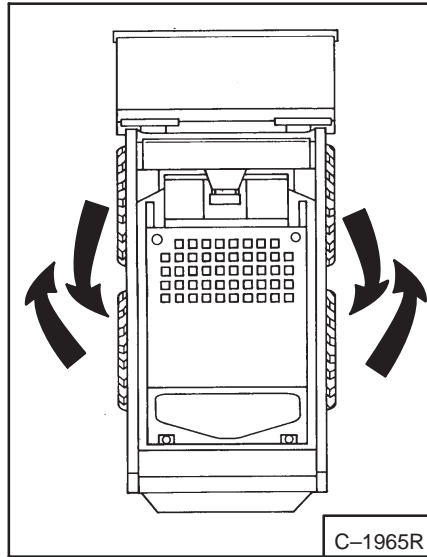


Fig. 1-47 Tire Rotation

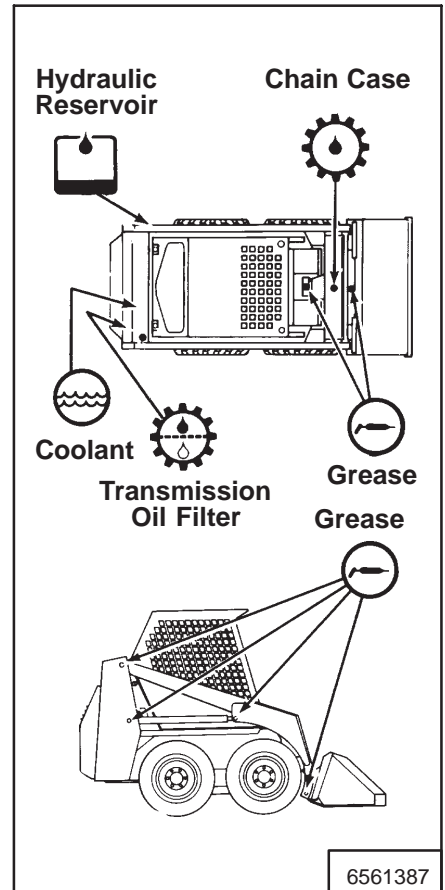


Fig. 1-48 Lubrication Points

## 1-11 LUBRICATION OF THE BOBCAT LOADER

Lubricate the Bobcat loader as specified in the Service Schedule on page 1-3 for best performance of the Bobcat loader.

See figure 1-48 for the location of grease fittings.

Always use a good quality lithium based multi-purpose grease when you lubricate the Bobcat loader. Apply lubricant until the extra grease shows.

Grease the universal joints and spline (Fig. 1-49, Item 1) every 250 hours.

Lubricate the seat rails for easy movement when you adjust the seat (Fig. 1-50, Item 1).

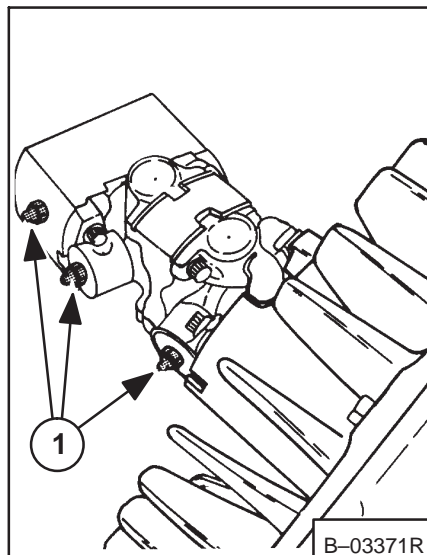


Fig. 1-49 Grease Universal Joints

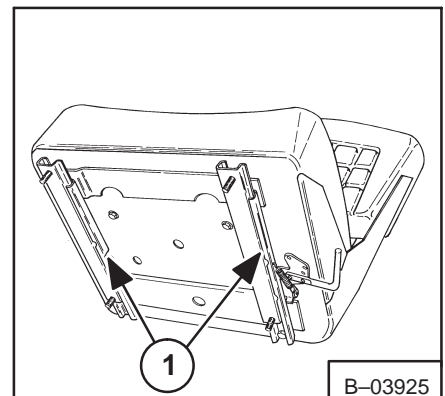


Fig. 1-50 Lubricating Seat

Add oil as needed to the steering control shaft (Fig. 1-51, Item 1). Add grease to steering pivot bearings (Item 2) every 250 hours.

### 1-12 OPERATOR GUARD

The Bobcat loader has an operator guard as standard equipment. The operator guard protects the operator from rollover and falling objects.

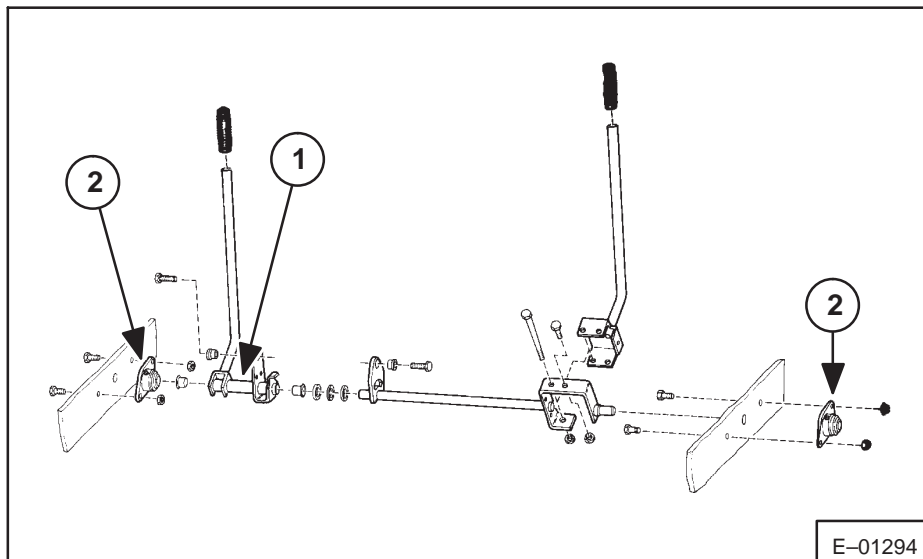


Fig. 1-51 Steering Control Lubrication

**WARNING**

**Never change the operator guard by welding, grinding, drilling holes or adding attachments that are not approved. This can weaken the operator guard and cause personal injury or death.**

W-2217-1195

Check with your authorized dealer if the operator guard has been damaged.

Make sure the operator guard fastening bolts and nuts are tight (Fig. 1-52).

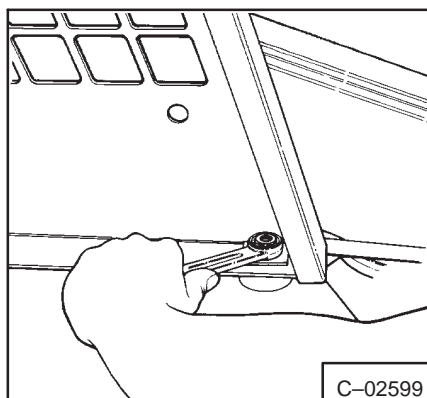


Fig. 1-52 Tightening Operator Guard Bolts

### 1-13 BOB-TACH

Check the Bob-Tach for wear or damage.

Check for free movement of wedges and Bob-Tach levers.

When the Bob-Tach levers (Fig. 1-53, Item 1) are pushed down into the locked position, the wedges must extend far enough to engage into the holes of the attachment (Fig. 1-54).

Replace wedges that are bent or broken.

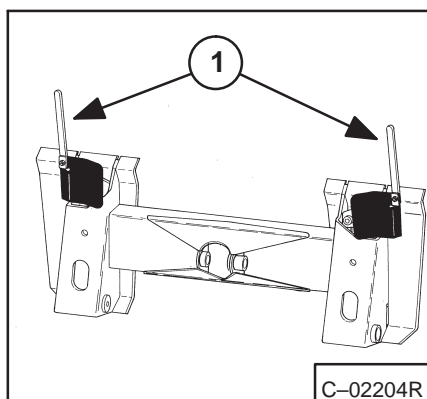


Fig. 1-53 Bob-Tach

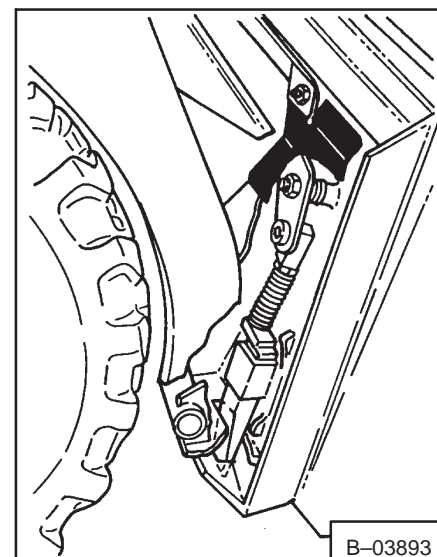


Fig. 1-54 Wedges



**Suggest:**

**If the above button click is invalid.**

**Please download this document**

**first, and then click the above link**

**to download the complete manual.**

**Thank you so much for reading**

## 1-14 PIVOT PINS

All pivot points, lift arms, Bob-Tach and cylinders have large pins that are held in position with lockbolts (Fig. 1-55, Item 1). Check that the lockbolts are tightened to 8-10 ft.-lbs. (11-13 Nm) torque. Do not overtighten.

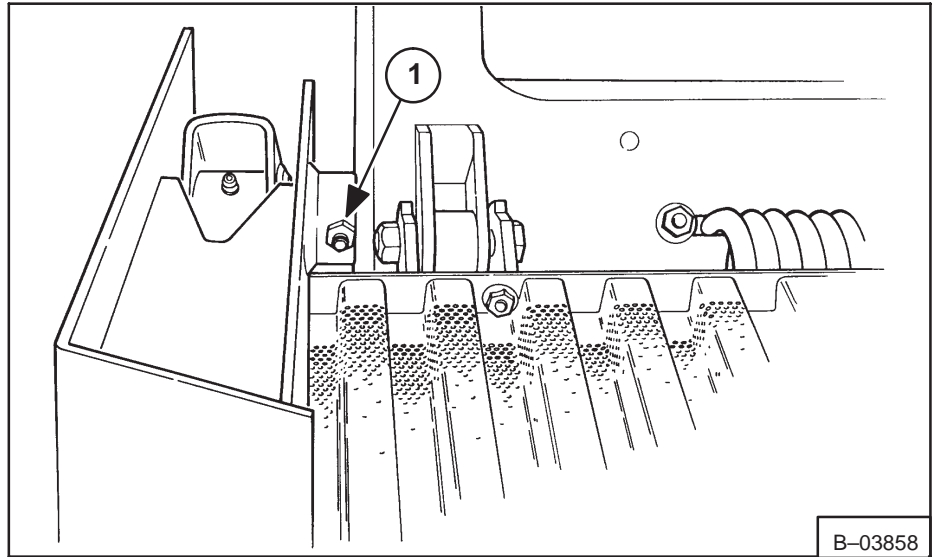


Fig. 1-55 Pivot Pin Lockbolts

## 1-15 AUXILIARY CONTROL LOCKBOLT

The auxiliary control has a lockbolt (Fig. 1-56, Item 1) that must be removed before you can use the auxiliary hydraulics (Fig. 1-57). The operator guard must be lifted before removing the lockbolt.

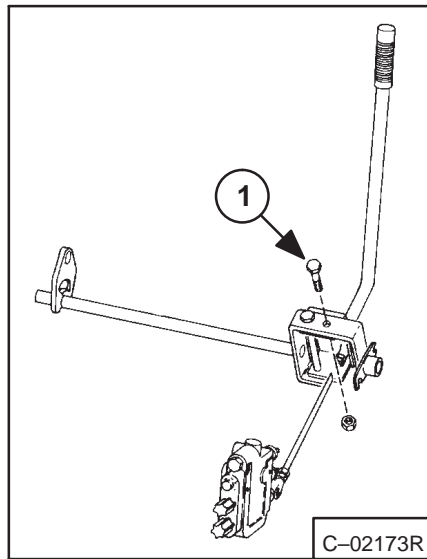


Fig. 1-56 Auxiliary Lockbolt

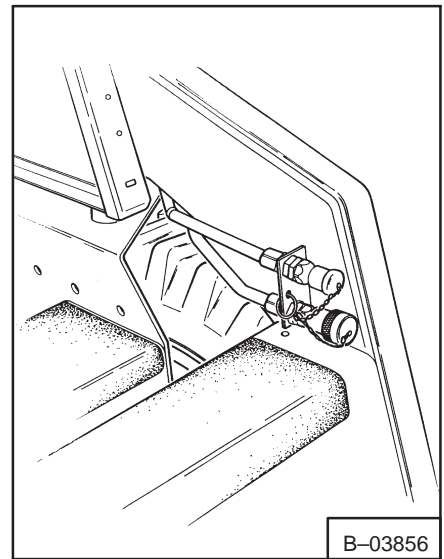


Fig. 1-57 Auxiliary Hydraulics

## 1-16 LIFT ARM STOP (Fig. 1-58)

1. Two persons are needed to install the lift arm stop. One person must be in the operator's seat, with the seat belt fastened, until the lift arm stop is installed.

2. Start the engine and raise the lift arms all the way up.
3. Have a second person install the lift arm stop over the rod end of one lift cylinder.

**NOTE:** Make sure the lift arm stop is tight against the cylinder rod.

4. Lower the lift arms until the top is held between the lift arms and the lift cylinder.
5. Stop the engine.

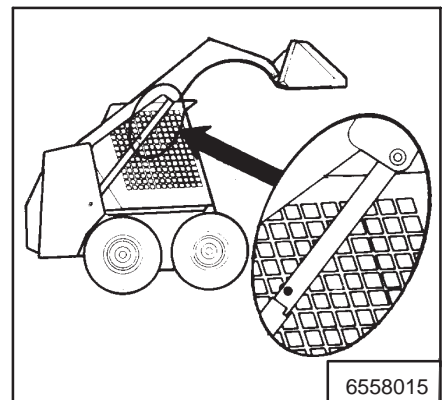


Fig. 1-58 Lift Arm Stop

**<https://www.ebooklibonline.com>**

Hello dear friend!

Thank you very much for reading.

Enter the link into your browser.

The full manual is available for immediate download.

**<https://www.ebooklibonline.com>**