

6
0
0

6
0
0
D

6
1
0

6
1
1



Service Manual

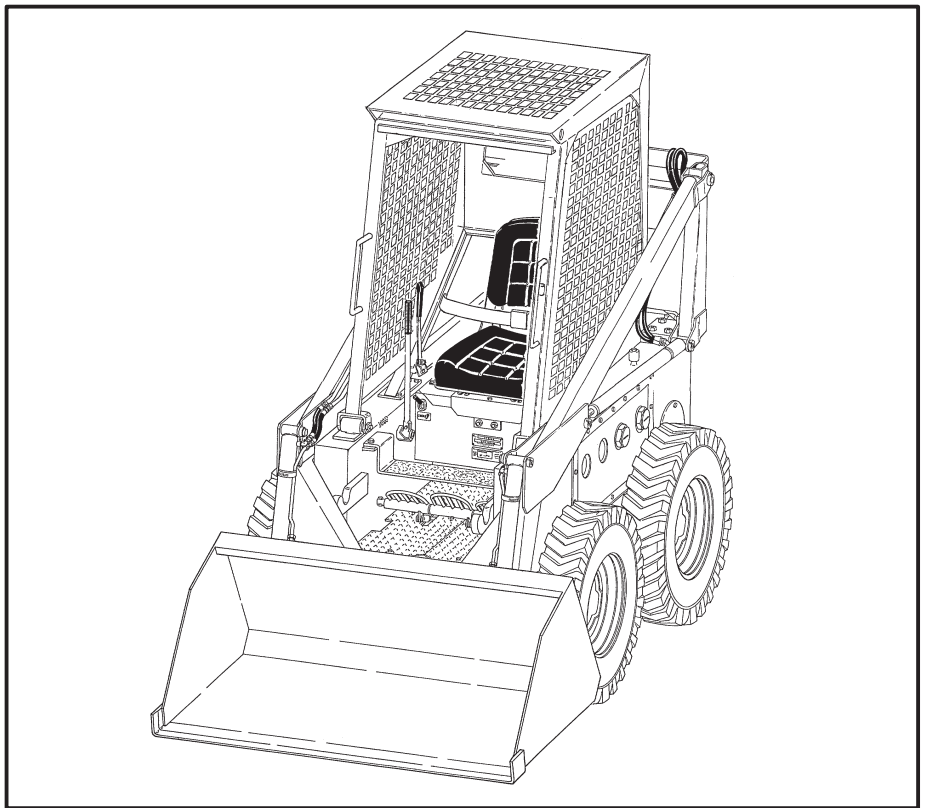

MELROE
INGERSOLL-RAND

6556276(6-87)

Printed in U.S.A.



© Melroe Company 1987

MAINTENANCE SAFETY



WARNING

Instructions are necessary before operating or servicing machine. Read and understand the Operation & Maintenance Manual, Operator's Handbook and signs (decals) on machine. Follow warnings and instructions in the manuals when making repairs, adjustments or servicing. Check for correct function after adjustments, repairs or service. Untrained operators and failure to follow instructions can cause injury or death.

W-2003-0903



Safety Alert Symbol: This symbol with a warning statement, means: "Warning, be alert! Your safety is involved!" Carefully read the message that follows.

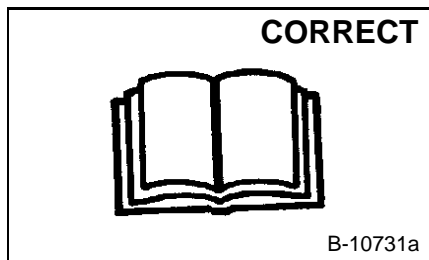

⚠ Never service the Bobcat Skid-Steer Loader without instructions.

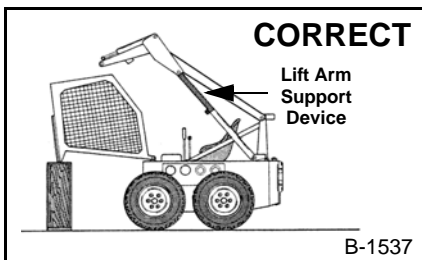

⚠ Use the correct procedure to lift or lower operator cab. Always use an approved lift arm support device to hold lift arms in raised position.

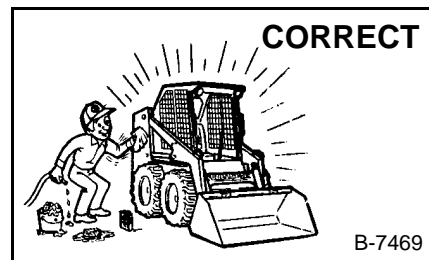

⚠ Cleaning and maintenance are required daily.

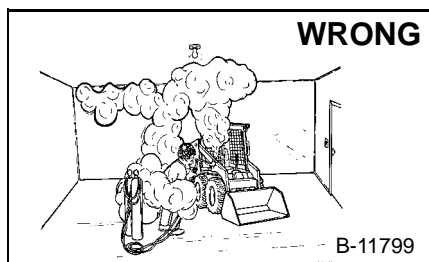

⚠ Have good ventilation when welding or grinding painted parts.
 ⚠ Wear dust mask when grinding painted parts. Toxic dust and gas can be produced.
 ⚠ Avoid exhaust fume leaks which can kill without warning. Exhaust system must be tightly sealed.

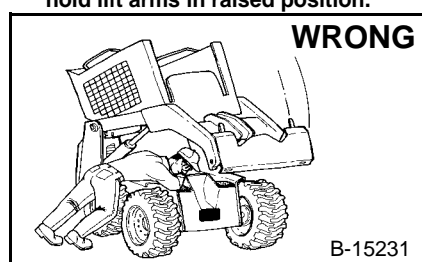

⚠ Disconnecting or loosening any hydraulic tubeline, hose, fitting, component or a part failure can cause lift arms to drop. Do not go under lift arms when raised unless supported by an approved lift arm support device. Replace it if damaged.

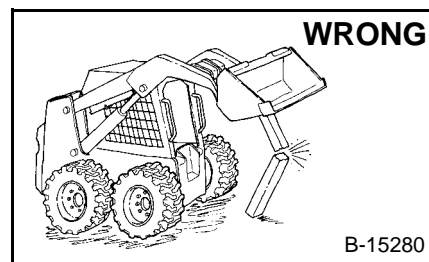

⚠ Never work on loader with lift arms up unless lift arms are held by a lift arm support device.
 ⚠ Never modify equipment or add attachments not approved by Bobcat Company.

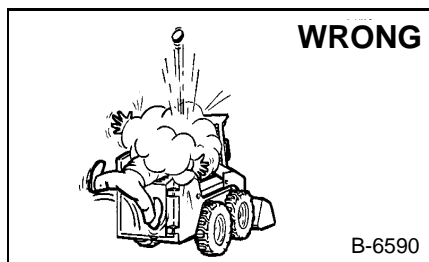

⚠ Stop, cool and clean engine of flammable materials before checking fluids.
 ⚠ Never service or adjust loader with the engine running unless instructed to do so in the manual.
 ⚠ Avoid contact with leaking hydraulic fluid or diesel fuel under pressure. It can penetrate the skin or eyes.
 ⚠ Never fill fuel tank with engine running, while smoking or when near open flame.

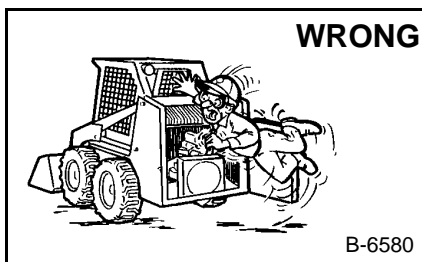

⚠ Keep body, jewelry and clothing away from moving parts, electrical contact, hot parts and exhaust.
 ⚠ Wear eye protection to guard from battery acid, compressed springs, fluids under pressure and flying debris when engines are running or tools are used. Use eye protection approved for type of welding.
 ⚠ Keep rear door closed except for service. Close and latch door before operating the loader.

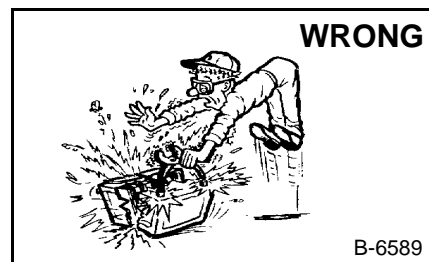

⚠ Lead-acid batteries produce flammable and explosive gases.
 ⚠ Keep arcs, sparks, flames and lighted tobacco away from batteries.
 ⚠ Batteries contain acid which burns eyes or skin on contact. Wear protective clothing. If acid contacts body, flush well with water. For eye contact flush well and get immediate medical attention.

Maintenance procedures which are given in the Operation & Maintenance Manual can be performed by the owner/operator without any specific technical training. Maintenance procedures which are **not** in the Operation & Maintenance Manual must be performed **ONLY BY QUALIFIED BOBCAT SERVICE PERSONNEL**. Always use genuine Bobcat replacement parts. The Service Safety Training Course is available from your Bobcat dealer.

FOREWORD

This manual provides instruction for proper routine servicing and adjustment of the Bobcat, and detailed overhaul instructions of the power train, loader hydraulic/hydrostatic system and general mainframe components.

Refer to the Owner's Manual for general operating instructions (Starting Procedure, Daily Check, Bucket Operation, Minor Maintenance, etc.).

A general inspection of the following items should be made whenever the machine has undergone service or repair:

1. Check hydraulic fluid level, engine oil level and fuel supply.
2. Inspect for any sign of fuel, oil or hydraulic fluid leaks.
3. Lubricate the machine.
4. Check battery condition, electrolyte level and cables.
5. Inspect air cleaner system for damage or leaks. Check element and make replacement, if necessary.
6. Check alternator drive belt for condition and tension.
7. Check for loose drive chains by lifting the rear of the machine and turning the rear wheels by hand.
8. Check tires for wear and pressure.
9. Check the Bob-Tach attachment for condition. Inspect the wedges for damage or wear.
10. Inspect safety items for condition (ROPS Guard, Seat Belt, Safety Treads, Lights, etc.).
11. Make a visual inspection for loose or broken parts or connections.
12. Operate the loader, checking all functions.

Advise the owner if any of the above items are in need of repair.

CONTENTS

ALPHABETICAL INDEX	9-1
DEUTZ ENGINE SERVICE	6-1
DRIVE SYSTEM	3-1
GENERAL SERVICE	1-1
HYDRAULIC SYSTEM	4-1
PETTER ENGINE SERVICE	7-1
SPECIFICATIONS	8-1
TROUBLESHOOTING	2-1
WISCONSIN ENGINE SERVICE	5-1

**GENERAL
SERVICE**

**TROUBLE-
SHOOTING**

**DRIVE
SYSTEM**

**HYDRAULIC
SYSTEM**

**WISCONSIN
ENGINE SERVICE**

**DEUTZ ENGINE
SERVICE**

**PETTER ENGINE
SERVICE**

SPECIFICATIONS

**ALPHABETICAL
INDEX**

GENERAL SERVICE

GENERAL SERVICE

	Paragraph Number	Page Number
CHANGING AND ADDING HYDRAULIC OIL	1-3	1-2
CRANKCASE AIR VENT (DEUTZ)	1-15	1-7
CRANKCASE AIR VENT (WISCONSIN)	1-14	1-7
DISTRIBUTOR MAINTENANCE (WISCONSIN)	1-22	1-10
ENGINE AIR CLEANER	1-6	1-4
ENGINE COOLING SYSTEM	1-19	1-8
ENGINE OIL	1-9	1-5
ENGINE OIL FILTER (DEUTZ)	1-12	1-6
ENGINE OIL FILTER (WISCONSIN)	1-11	1-6
FUEL ADJUSTMENT (PETTER)	1-18	1-8
FUEL FILTERS	1-17	1-7
FUEL SPECIFICATIONS	1-16	1-7
HEAVY DUTY AIR CLEANER	1-8	1-4
HYDRAULIC FLUID FILTER CHANGE	1-5	1-3
IGNITION TIMING (WISCONSIN ENGINE)	1-21	1-9
LOADER LUBRICATION	1-2	1-2
OIL FILTER (PETTER)	1-13	1-6
OIL SPECIFICATIONS FOR ENGINES	1-10	1-5
OIL TYPE AIR CLEANER	1-7	1-4
REMOVING WATER FROM HYDRAULIC TANKS	1-4	1-2
SPARK PLUG (WISCONSIN)	1-23	1-10
TIRES	1-1	1-2
WATER SCRUBBER MUFFLER (600 DIESEL)	1-20	1-8

<https://www.ebooklibonline.com>

Hello dear friend!

Thank you very much for reading.

Enter the link into your browser.

The full manual is available for immediate download.

<https://www.ebooklibonline.com>

SERVICE SCHEDULE			HOURS							
MODEL	ITEM	SERVICE REQUIRED	8-10	40-50	80-100	200	300	500	1000	2000
G,D,P,E	All Loader Pivots	Grease fittings (10) until excess shows.								
G,D,P	Engine Air Cleaner (Dry Type)	Clean cup as necessary. Change cartridge only when indicator show red ring.								
D	Oil Bath Air Cleaner	Check condition of oil								
G,D,P	Engine Oil	Add to full mark. Do not overfill. Use correct oil for engine.								
G,D,P*	Engine Air Inlet Screen	Check and clean as necessary.								
G,D,P	Cooling Fins & Shroud	Backflush with air as necessary.								
G,D,P	Starting Motor	Flush with air as necessary.								
E	Cable Swivel	Put grease in fittings (2) until it shows.								
G,D,P,E	Variable Sheaves	Put grease in fittings (2); drive and driven sheave.								
G,D,P,E	Control Levers & Pedals	Put grease in fittings (7) until it shows.								
G,D,P	Engine Oil	Make replacement. Refer to Engine Manual.								
G,D,P	Engine Oil Filter	Make replacement of element.								
G	Distributor Cam (Wisconsin)	Put drop of oil in spring cap oil cup.								
G,D,P,E**	Final Drive Chains	Make adjustment as necessary.								
D	Oil Bath Air Cleaner (Bureau of Mines)	Clean and refill with engine oil.								
G,D,P	Engine Air Cleaner (Dry Type)	Check operation of condition indicator.								
G,D,P,E	Hydraulic Oil Filter	Make replacement at 100 hours.								
G,D,P	Crankcase Breather	Inspect. Service as necessary.								
G,D,P,E	Steering Clutches	Make adjustment when lever travel exceeds 3-4 inches from neutral in either direction (fully engaged).								
D	Engine Valve Tappets	Check clearance. Make adjustment if necessary.								
G	Plugs & Points	Clean. Gap install new as necessary. Tighten spark plugs.								
G	Generator (M-444)	Add lubricant.								
D	Engine Fuel Filter	Clean or install new element.								
D	Engine Blower V-Belt Tension	Check. Make adjustment as necessary.								
P	Engine Valve Tappets	Check clearance. Make adjustment if necessary.								
G	Engine Cylinder	If over 90 PSI compression remove carbon from combustion chambers.								
G,D,P	Engine Shroud	Remove to clean engine cooling fins.								
G,D,P,E	Drive Belt & Sheaves	Check for tension, alignment and wear.								
G,D,P	Starting Motor	Remove, clean and service.								
G	Engine	Remove head. Clean carbon from combustion chambers. Make adjustment of valves if necessary.								
D	Crankshaft Breather	Clean copper mesh element.								
G,P,D,P	Hydraulic, Transmission Sump	Remove condensation. Check level. Add as necessary.								
P	Engine Fuel Filter	Clean or install new element.								
P	Oil Pump Strainer	Clean.								
P	Engine Cylinders	Remove carbon from combustion chambers.								
E	Motor Bearings	Add lubricant. For interval, follow instructions plate on motor.								
G,D,P,E	Hydraulic, Transmission Sump	Make replacement of oil. Approximately 18 gallons are needed.								

Model Code: G, Gasoline & LP Gas; D, Deutz Diesel; P, Petter Diesel; E, Electric

* On fertilizer, grain or other extremely dusty operations, clean more often as required.

** Adjust after first 50 hours of operation. Check daily if solid type tires are used.

GENERAL SERVICE

1-1 TIRES

Tire air pressure on standard 7:00 x 15,6 ply should be 55 PSI (379 kPa). Flotation tire air pressure should be 25 PSI (172 kPa). Air pressure must be the same in all tires for longer life.

Tires can be filled with calcium chloride for more load stability and traction. They must not be filled to more than 80% of capacity of tire.

NOTE: Flotation tires should not be filled with calcium chloride except in pulpwood operation.

Tire rotation should be done when 1/8 inch (3,2 mm) difference is found in wear of tire (Fig 1-1).

When putting new tire on loader, check that size is the same as other tires on loader.

1-2 LOADER LUBRICATION

See Fig. 1-2 for lubricate fitting locations. Use a good lithium base grease. Check service schedule (Page 1-1) for correct time intervals.

1-3 CHANGING AND ADDING HYDRAULIC OIL

The loader holds 18 gallons of hydraulic oil which need not be changed unless loader is run under very dirty conditions for a long period of time. Otherwise change oil every 1000 hours or if oil has become dirty or white in color.

Check oil level every 50 hours of operation, on a level surface. When low add approved oil and fill to the upper check plug (Fig. 1-3).

1-4 REMOVING WATER FROM HYDRAULIC TANKS

Water should be removed every 1000 hours of operation or more often if loader is operated in a climate where much water is present in the air.

To remove water from the reservoir:

1. Use tilt control to raise front wheels of the loader several inches off of the ground.
2. Allow the loader to stand for 3-4 hours.
3. Remove drain plug (Fig. 1-3) for water to run off .

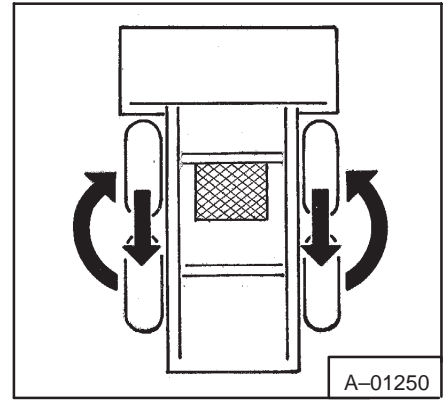

Fig. 1-1 Tire Rotation

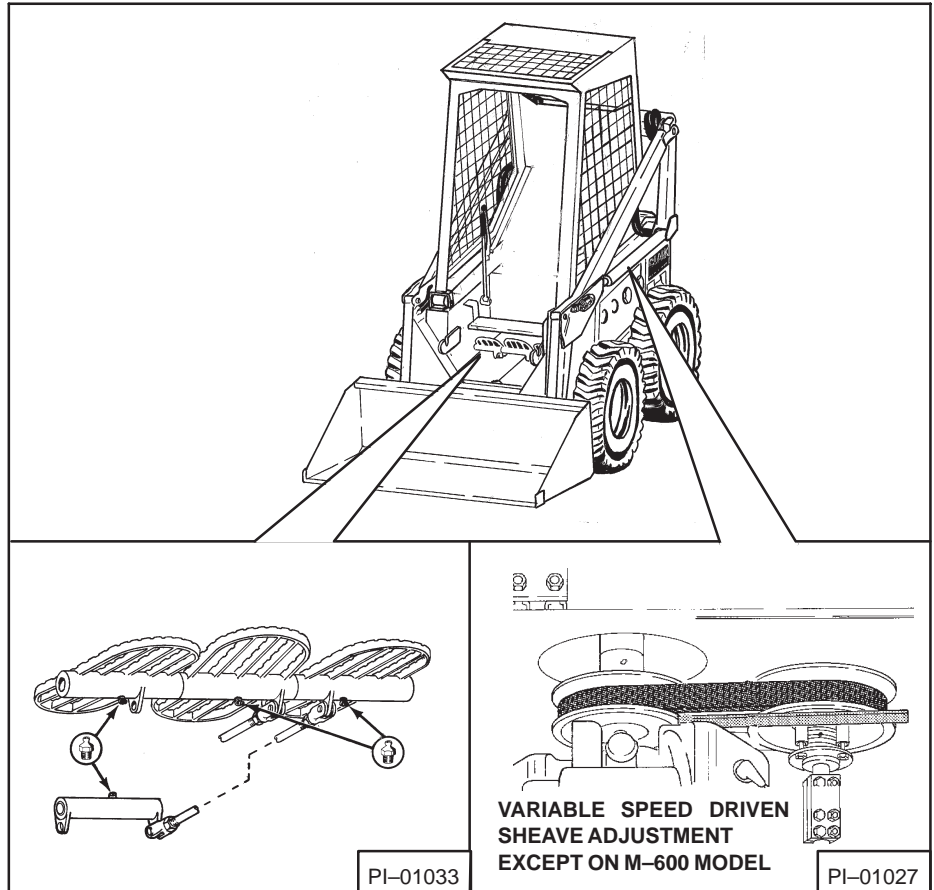

Fig. 1-2 Loader Lubrication

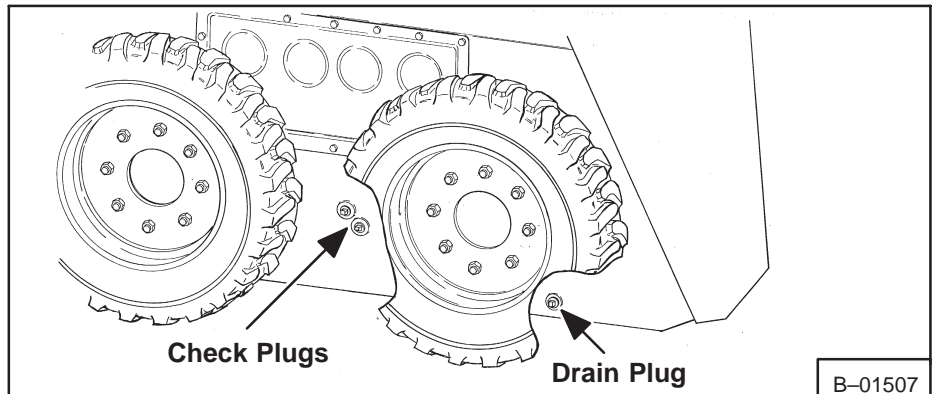

Fig. 1-3 Reservoir Check and Drain Plugs

1-4a BOB-TACH FRAME

Check Bob-Tach and weld areas as necessary (Fig. 1-3a).

1-5 HYDRAULIC FLUID FILTER CHANGE

See *SERVICE SCHEDULE* Page 1-1 for time interval.

1. Lower lift arms. Lift front of the loader 5-6 inches (127-152 mm) on 600 Electric and Petter diesel. Lift rear of machine 5-6 inches on 600, 610 and Deutz diesel. This will prevent oil from running out when filter is removed.
2. Remove floor panels and disconnect linkage (600 Electric and Petter diesel).
3. Remove seat and engine cover (600, 610 and Deutz 610).
4. Remove element, seals and spring from housing (Fig. 1-4).
5. Remove seal from center shaft (Fig. 1-4, Item 1).
6. Clean parts in a cleaning fluid and dry.
7. Assemble new filter (Fig. 1-4).
8. Check housing seal (Fig. 1-4, Item 2).
9. Install filter assembly to loader and tighten nut to 12 ft.-lbs. (83 kPa) (Fig. 1-5).
10. Lower the loader and run engine at idle until hydraulics work smoothly.
11. Check for leaks and check level of fluid. It should need 2 quarts (1.9 ltr.) for filter element. Fill to the upper check plug (Fig. 1-6).

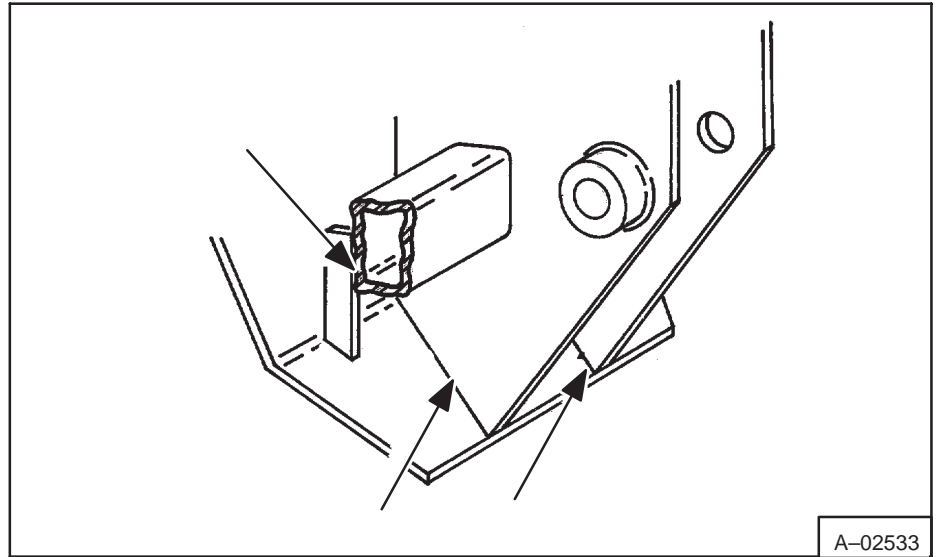

Fig. 1-3a Weld Areas

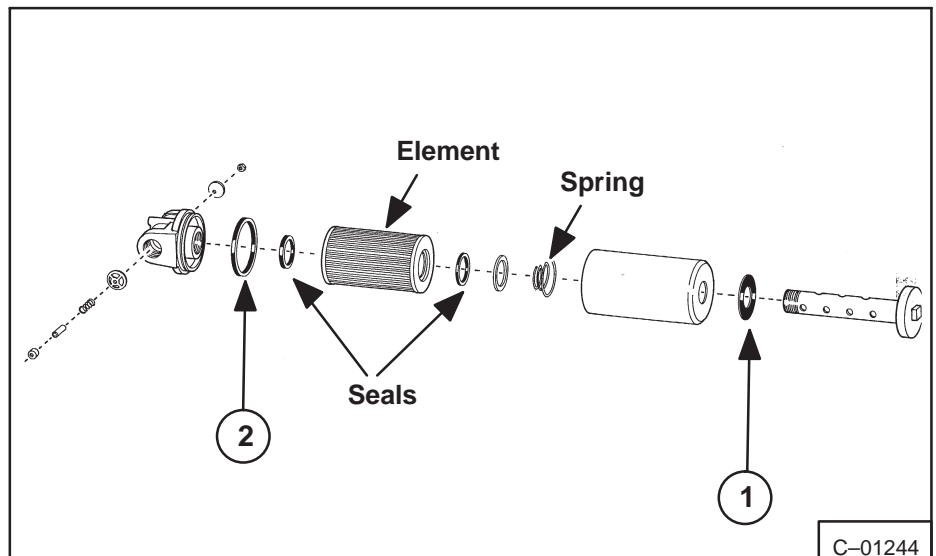

Fig. 1-4 Hydraulic Fluid Filter Assembly

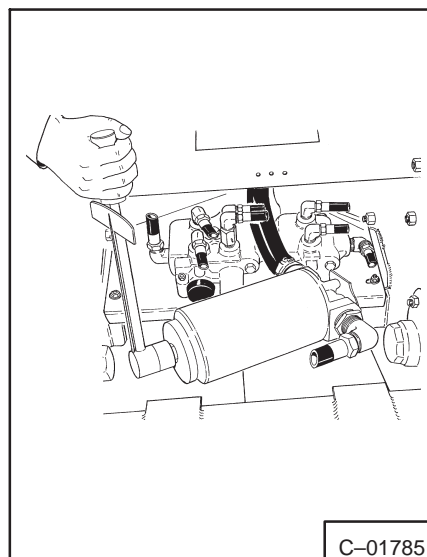

Fig. 1-5 Installing Filter Assembly

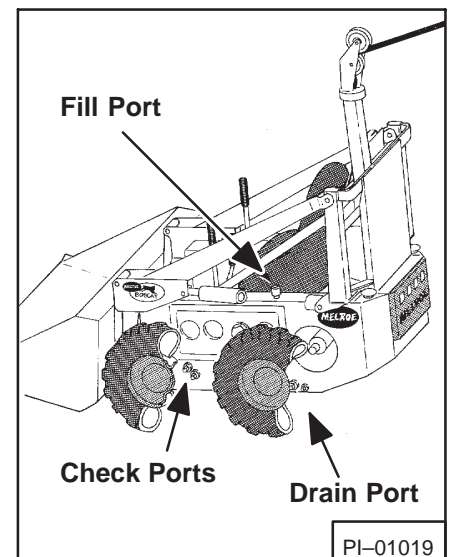

Fig. 1-6 Hydraulic fluid Level Check

1-6 ENGINE AIR CLEANER

1. See *SERVICE SCHEDULE* (Page 1-1) for intervals.
2. Clean all foreign material from outside of housing.
3. Remove old element (Fig. 1-7).
4. Install new element (Fig. 1-7).
5. Set indicator ring back to normal (Fig. 1-8).
6. Inspect air cleaner for leaks:
 - a. Dust cap holder
 - b. Filter gasket
 - c. Dust cap
 - d. Dust cap sealing edge
 - e. Filter leaks
 - f. Hose and connections.
 - g. Check system by removing dust cover and hold hand over inlet with engine running at idle to 1/4 throttle. Engine should stop (Fig. 1-11). Reset indicator and install dust cover.

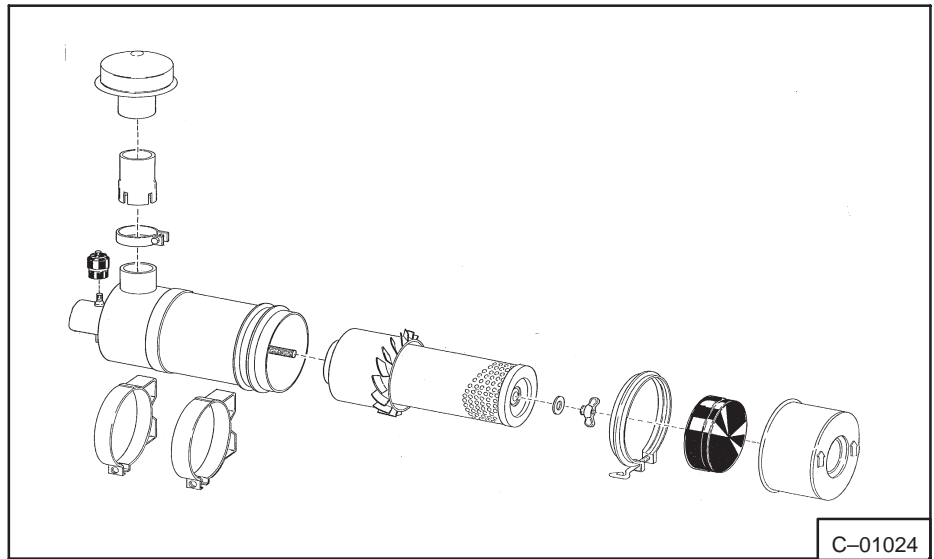

Fig. 1-7 Air Cleaner Assembly

1-7 OIL TYPE AIR CLEANER

1. Stop loader and let stand for one hour.
2. Remove bottom cup and clean.
3. Fill cup with oil to correct level (Fig. 1-9).
4. Install cup.

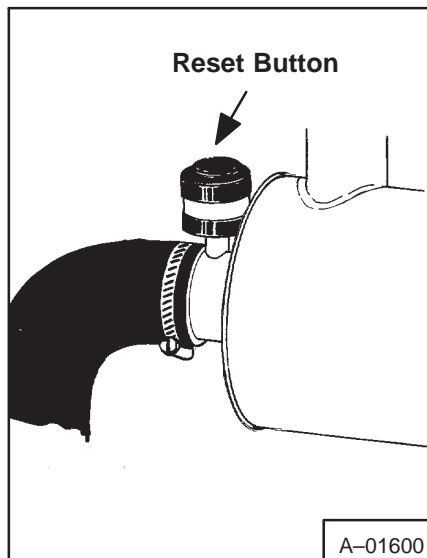

Fig. 1-8 Condition Indicator

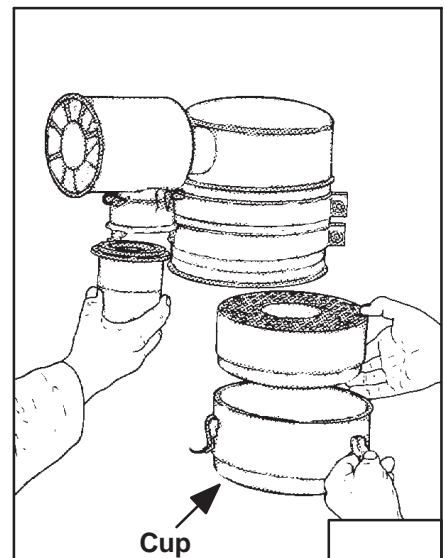

Fig. 1-9 Oil Bath Air Cleaner

1-8 HEAVY DUTY AIR CLEANER

1. An indicator located on front of air cleaner indicates condition of filter (Fig. 1-10).
2. When red ring is in window, remove element and install new element (Fig. 1-10).

NOTE: Do not clean or install old element.

3. Inspect hoses and connection for leaks.
4. Inspect and clean vanes on air cleaner (Fig. 1-10).

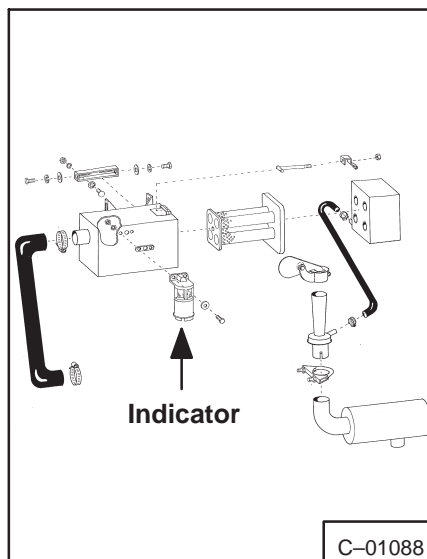

Fig. 1-10 Heavy Duty Air Cleaner

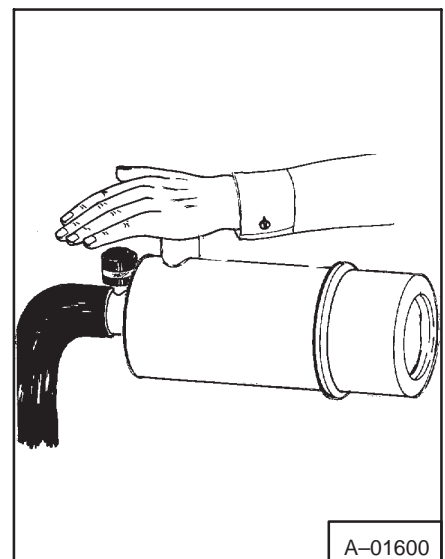

Fig. 1-11 Checking System

1-9 ENGINE OIL

1. Check *SERVICE SCHEDULE* on page 1-1 for time interval.
2. Empty oil when engine is warmed up.
3. Capacity of oil for engine follows:

Wisconsin=7 pints (3,3 L)+1 pint (.5 L) when filter is changed.

Deutz=4-1/2 quarts (4,2 L) with filter.

Petter=5-1/2 quarts (5,1 L) with filter.

1-10 OIL SPECIFICATIONS FOR ENGINES

Replace the engine oil and filter every 50 hours of loader operation.

RECOMMENDED SAE VISCOSITY NUMBER (LUBRICATION OILS FOR ENGINE CRANKCASE)

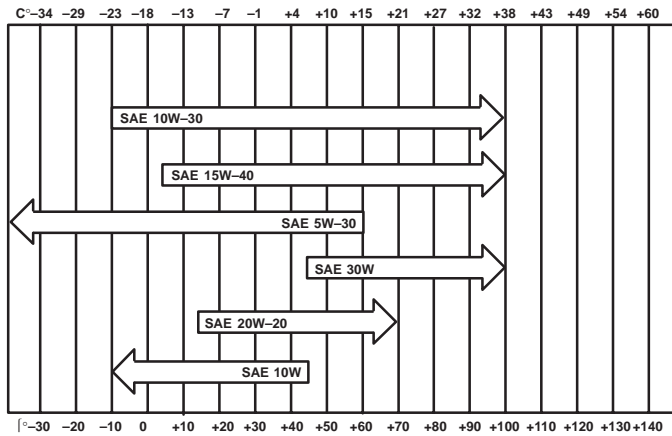

TEMPERATURE RANGE ANTICIPATED BEFORE NEXT OIL CHANGE
(GASOLINE: USE API CLASSIFICATION SE)
(DIESEL: USE API CLASSIFICATION CD)

1-11 ENGINE OIL FILTER (Wisconsin)

Check *SERVICE SCHEDULE* Page 1-1 for time interval.

1. Remove filter element (Fig. 1-12).
2. Install new filter and hand tighten (Fig. 1-13).
3. Start engine and check for leaks.
4. Run engine at full throttle for 1 minute then stop engine.
5. Tighten filter by hand.

1-12 ENGINE OIL FILTER (Duetz Diesel – Fig. 1-13)

Change the filter element at every engine oil change. To change the filter, use this procedure:

1. Remove and discard the oil filter cartridge.
2. Install a new filter cartridge, turn it on hand tight.
3. Start the engine and run it at idle for five minutes while checking for oil leaks at the filter.
4. Run the engine at full throttle (2400 RPM) for at least one minute, then stop engine.
5. Tighten the cartridge again (hand tight).

OIL FILTER (Petter)

See *SERVICE SCHEDULE* Page 1-1 for time interval.

1. Remove filter cover (Fig. 1-14).
2. Remove oil filter element.
3. Clean filter housing and remove dirt and oil.
4. Install new element and tighten cover to 10 ft.-lbs. (13,55 Nm).

NOTE: After installing oil filter on engines, run engine and check for leaks. Stop engine and check oil level.

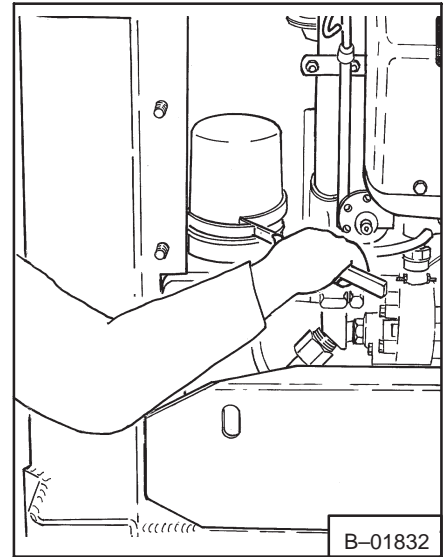

Fig. 1-12 Remove Engine Oil Filter

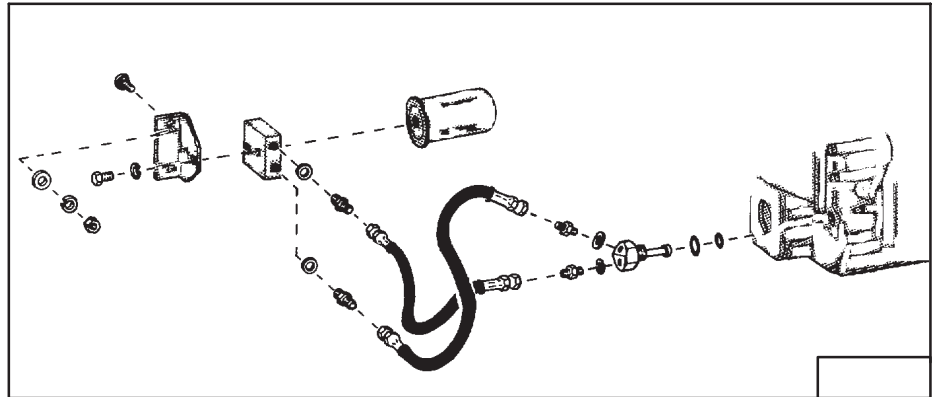

Fig. 1-13 Install Engine Oil Filter (Deutz)

! **WARNING**

Cold weather starting (below 32°F.) with heavier than 10W engine oil can stretch the filter cartridge causing a leak. Tighten the filter cartridge after every few cold starts to be sure it stays tight.

W-2265-0997

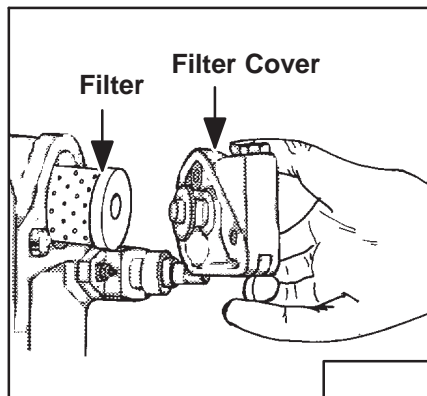

Fig. 1-14 Remove Filter cover (Petter)

1-14 CRANKCASE AIR VENT (Wisconsin)

See *SERVICE SCHEDULE* Page 1-1 for time interval. Inspect fittings and hoses for leaks (Fig. 1-15).

1-15 CRANKCASE AIR VENT (Deutz)

See *SERVICE SCHEDULE* Page 1-1 for time interval. The vent housing contains a copper element as a filter.

1. Remove bolts that hold crankcase vent housing in place (Fig. 1-16).
2. Remove housing and vent tube assembly from engine (Fig. 1-17). Lay it face up and install clean copper element.
3. Install vent tube on engine. Check that housing is correct on engine. Seal it using an industrial cement before tightening bolt.

NOTE: Remove vent tube from engine every 500 hours and wash element in cleaning solvent.

1-16 FUEL SPECIFICATIONS

Wisconsin engine uses regular gasoline.

Deutz engine uses a number 2 diesel fuel for temperatures above 30°F.

Petter engine uses number 2 diesel fuel.

1-17 FUEL FILTER

L.P. Gas: A filter with an ignition switch actuated shut-off lock is located between the inlet hose and vaporizer. This must be serviced regularly. Remove the old element and install new element when servicing (Fig. 1-18).

Deutz: Remove fuel filter and install new filter every 200 hours (Fig. 1-19). Air removal from fuel lines is necessary after filter service.

Petter: Remove fuel filter and install new filter every 1000 hours (Fig. 1-20). Air removal from fuel line is necessary after filter service.

Wisconsin: Remove in-line filter every 200 hours. Check condition by blowing through element, in same direction as arrow. Make replacement of dirty element.

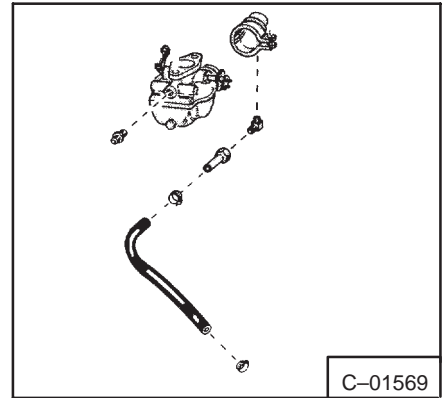

Fig. 1-15 Crankcase Air Vent (Wisconsin)

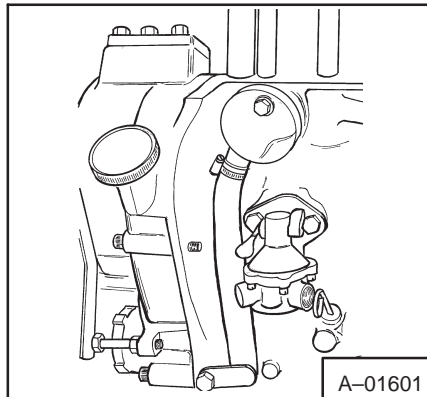

Fig. 1-16 Crankcase Breather (Deutz)

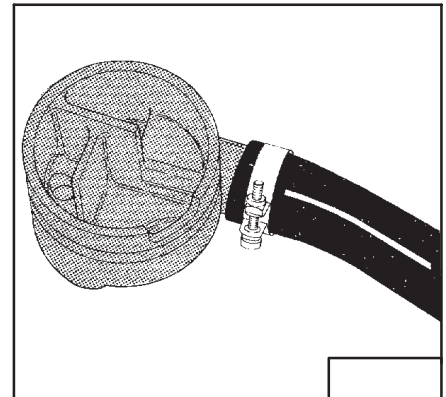

Fig. 1-17 Deutz Breather W/Element

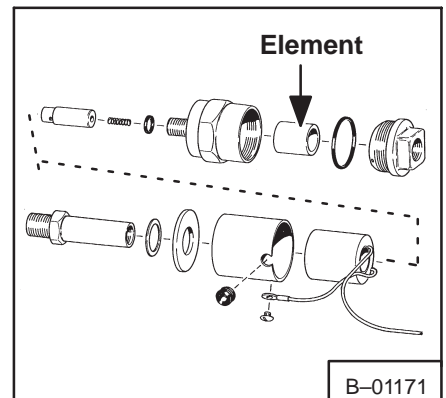

Fig. 1-18 LP Gas Fuel Filter

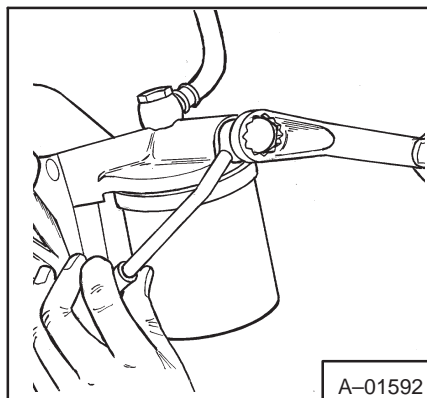

Fig. 1-19 Deutz Fuel Filter

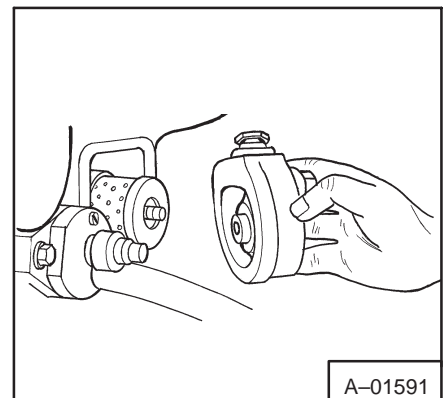

Fig. 1-20 Petter Fuel Filter

1-17a EXCESS FUEL LEVER ADJUSTMENT (Deutz Engine)

Engine does not start because excess fuel lever does not operate correctly. The excess fuel button must be pushed fully down, when the throttle lever is pulled all the way backward while stopping the engine, this is done through movement of the excess fuel lever (Fig. 1-20a).

Check the operation of the lever by pulling the throttle lever fully backward. While the throttle is held in this position check to see if the excess fuel button is pushed down by the adjustment bolt (Fig. 1-20b, Item 1). Make an adjustment of the bolt if necessary to fully push the excess fuel button down. Install a longer bolt if no more adjustment can be made.

If necessary make additional adjustment by bending the cam plate end of the excess fuel lever (Fig. 1-20a, Item 2) down. (Do not bend the plate so much as to prevent full movement of the fuel rack lever (Fig. 1-20a, Item 3).

After adjustment is made check the operation by pulling throttle lever all the way backward as in stopping the engine. Then move throttle forward to the 1/2 throttle position. Check the excess fuel button. It must continue to be in the down position for starting the engine. If the button is not down, more adjustment of the excess fuel lever is necessary.

1-17b FUEL PUMP (Wisconsin)

If fuel pump pressure is too high the engine will get too much fuel. Check fuel pump pressure by installing a tee in the fuel line between fuel pump and carburetor and connecting a gauge to the tee. Run the engine at full RPM. Correct pressure is 2-3 PSI. If pressure is too high, install new spring from fuel pump repair kit. (See Parts Manual.)

NOTE: Too low pressure will cause vaporlock.

Make adjustment of float level to 1-5/32 inch (28,58 mm).

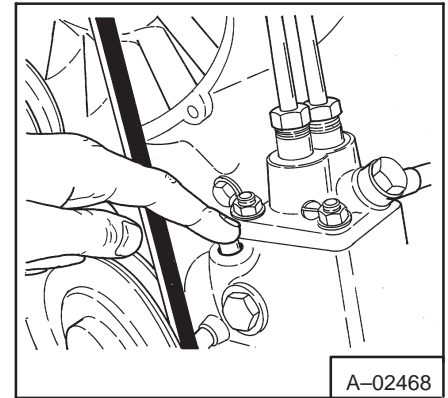

Fig. 1-20a Excess Fuel Button

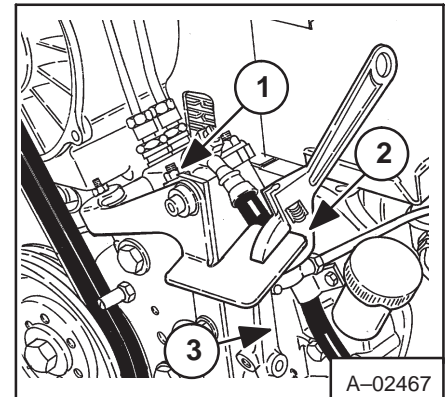

Fig. 1-20b Excess Fuel Lever Adjustment

1-18 FUEL ADJUSTMENT (Petter)

1. Stop engine.
2. Remove cover plug (Fig-1-21).

NOTE: When loader is not equipped with a hole in loader side wall at fuel adjustment screw location see Fig. 1-21 for hole drilling instructions. The hole will make fuel adjusting easier.

3. Put a screw driver into hole (Fig.1-21). Turn in to reduce fuel supply, turn out to increase fuel supply.
4. Install plug. Start engine and check its operation. Set for a maximum power and minimum smoke.

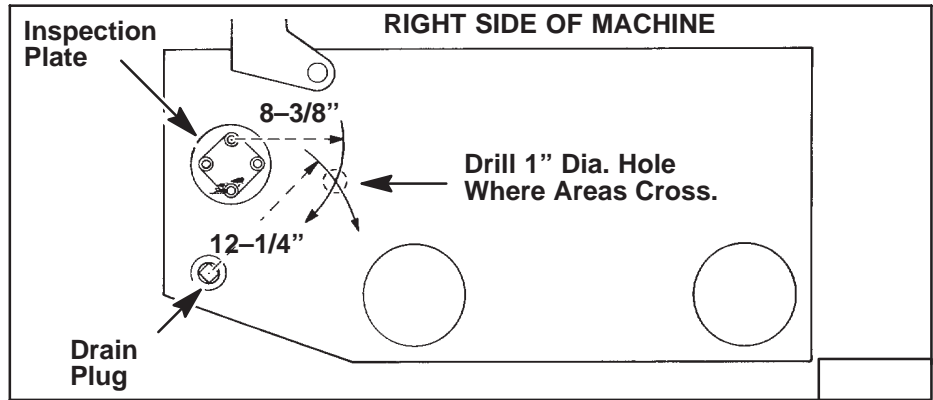

Fig. 1-21 Locating Fuel Adjustment Hole (Petter)

1-19 ENGINE COOLING SYSTEM

1. All air cooled engines must have proper air circulation to cool well.
2. Keep blower fan and screen clear of foreign material and housing free of leaks and dents.
3. Remove housing and clean cooling fins when need (Fig. 1-22, 1-23, & 1-24).

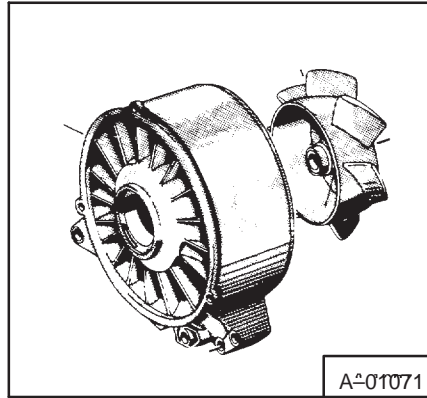

Fig. 1-22 Deutz Cooling Fan

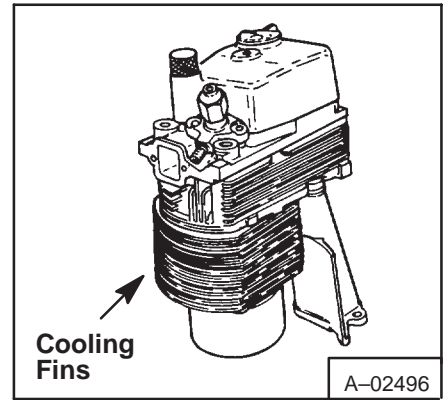

Fig. 1-23 Clean Cooling Fins (Petter)

! WARNING

Never run the engine with holes in cooling housing or with any part of cooling housing removed.

W-2266-0997

1-20 WATER SCRUBBER MUFFLER (600 Diesel)

The following applies to United States Bureau of Mines approved model 600 equipped with an exhaust gas conditioner (Water Scrubber Muffler).

1. Exhaust pipe and connections from engine to exhaust gas conditioner must be kept tight and free from leaks at all times.
2. Empty scrubber at bottom outlet with engine running, after each shift (10 hours).
3. Fill with clean water until water level reaches level check valve located on front of scrubber (Fig.1-25).
4. Flush scrubber twice weekly by filling it with water while engine is running at high idle. This will agitate water and any excess will be blown out with exhaust gas.

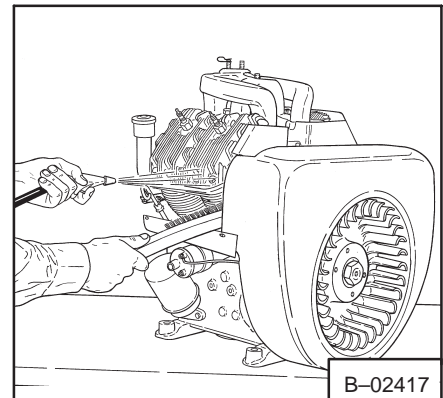

Fig. 1-24 Cleaning Cooling Fins (Wisc.)

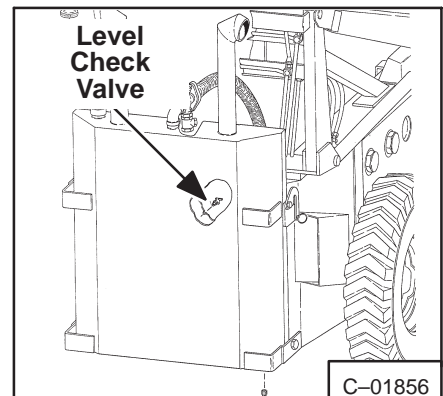

Fig. 1-25 Check Level Scrubber Muffler

5. Check exhaust, check valve (located between engine and exhaust gas conditioner) (Fig. 1-26). Check each day to make sure it will open when suction is applied to exhaust pipe. The check valve is intended to keep water from entering engine in event engine turns over backwards (opposite of normal rotation).

1-21 IGNITION TIMING (Wisconsin Engine)

Find the timing notch on air screen of flywheel and make sure it is positioned in line with the large DC letters on flywheel, behind screen (Fig. 1-27).

NOTE: Ignition point gap must be correct before timing engine.

To check timing:

1. Connect timing light to number one spark plug.
2. Start engine and run at over 1800 RPM.
3. Point timing light so that it will show the notch on flywheel screen (Fig. 1-28).
 - a. VF4D engine (Model 600 Bobcat) is timed at 27° before dead center. Check to see that timing notch is in line with the timing mark on flywheel housing (Fig. 1-27, Item 1).
 - b. VH4D engine (Model 610 Bobcat) is timed at 23° before dead center. Check to see that timing notch is in line with the lower half of the timing hole in flywheel housing (Fig. 1-27, Item 2).
4. To adjust timing, loosen the distributor clamp screw and turn the distributor body until timing is correct (Fig. 1-29).
5. When timing is correct, tighten the distributor clamp screw.

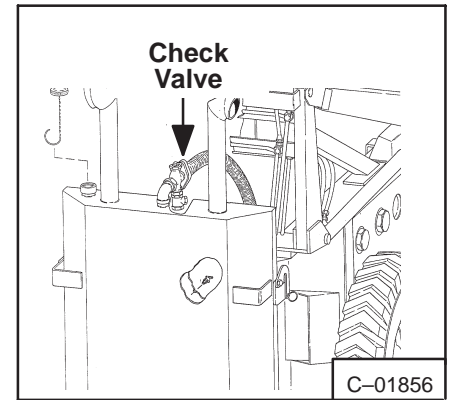

Fig. 1-26 Exhaust Check Valve

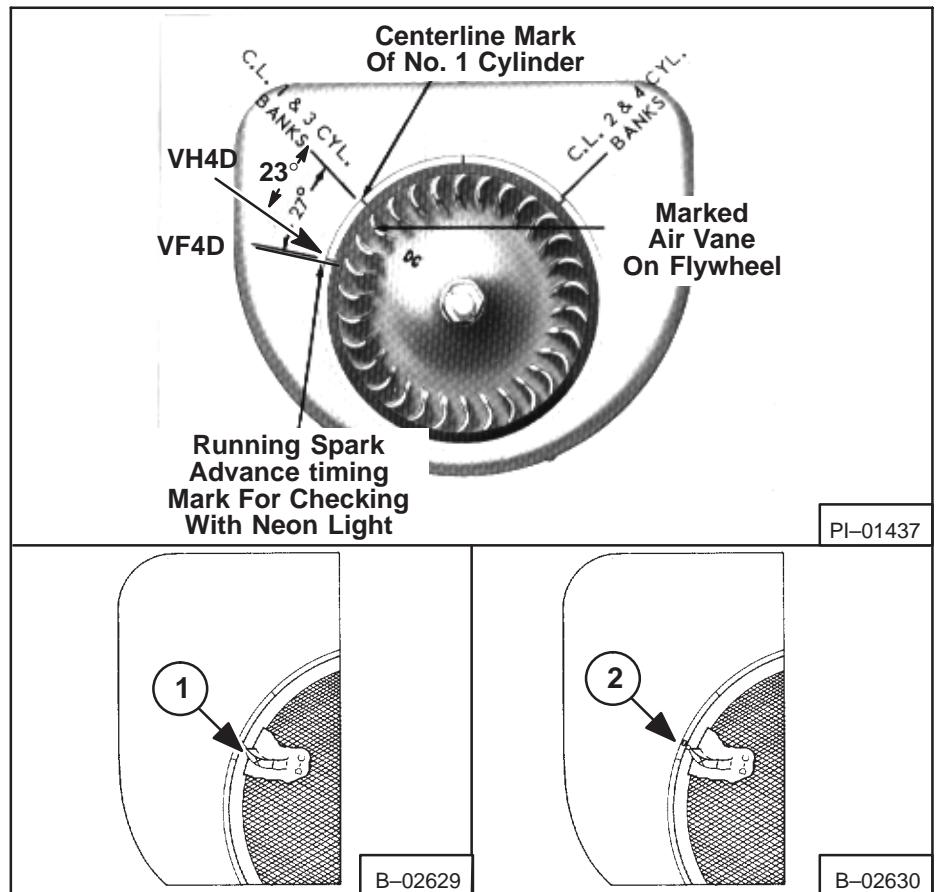

Fig. 1-27 Ignition Timing

WARNING

Engine must be running at over 1800 RPM when making timing adjustment. Wrong engine timing can damage engine.

W-2267-0997

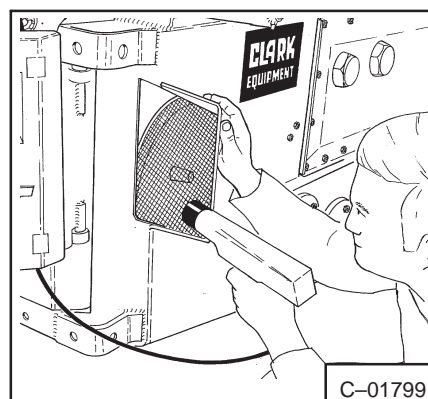

Fig. 1-28 Check Notch W/ Timing Light

1-22 DISTRIBUTOR MAINTENANCE (Wisconsin)

1. Turn the engine over by hand until the breaker arm block is on a high point of cam (Fig. 1-29).
2. Loosen the stationary contact lock nut and turn screw in or out until contact gap is correct (Fig. 1-29).
3. Tighten the lock nut and check gap (Fig. 1-29).

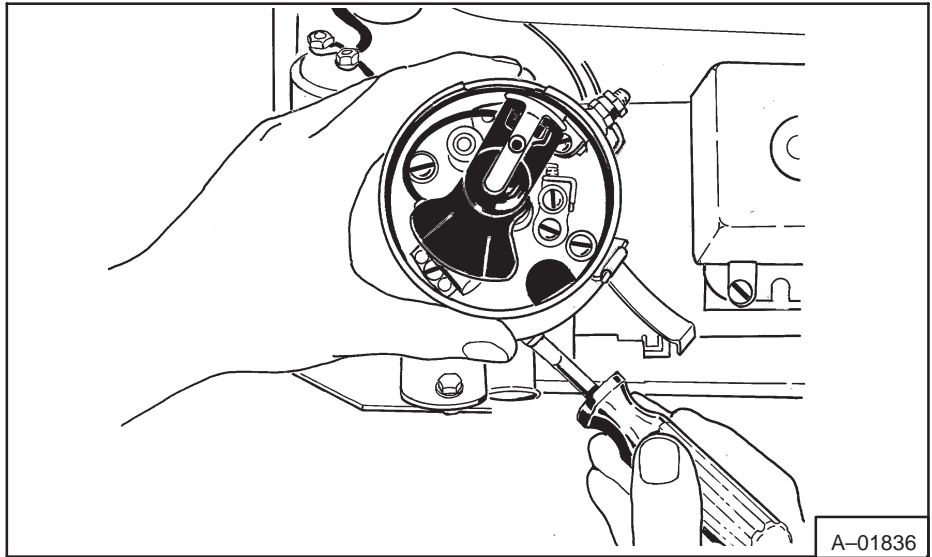

Fig. 1-29 Distributor Maintenance

1-23 SPARK PLUG (Wisconsin)

The spark plug gap should be .030 inch. Plug should be kept clean both inside and out (Fig. 1-30). When insulation is broken, install a new plug of correct heat range. Tighten the spark plug to 25-30 ft.-lbs. (34-40 Nm) torque.

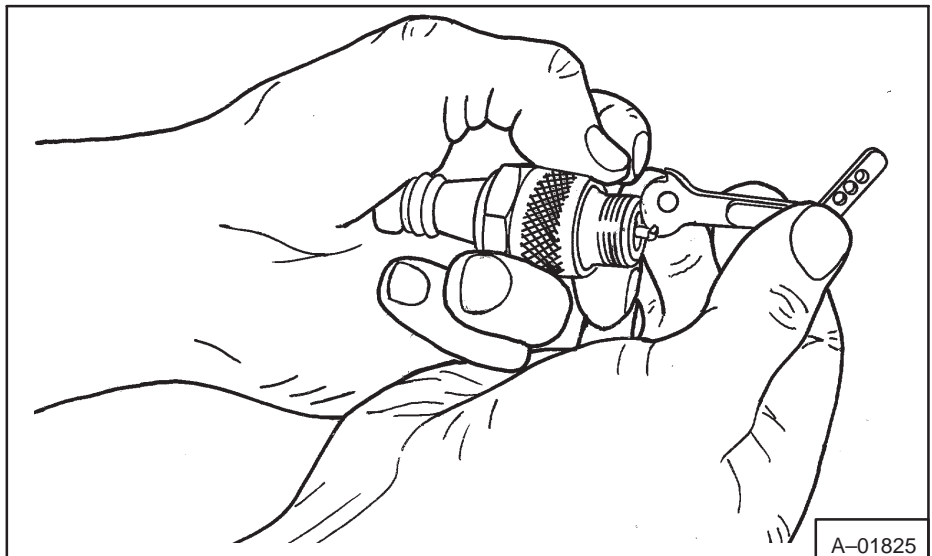

Fig. 1-30 Spark Plug Gap

1-24 ELECTRICAL SYSTEMS

CHECKING REGULATOR AND RECTIFIER

NOTE: Read this completely before attempting any checks.

VF4D Wisconsin engines have the rectifier and regulator modules mounted to the shroud at the rear of the engine. On some engines the rectifier and regulator modules are behind the distributor. They are hard to check the service. You may want to move the modules out onto the shroud. To do this:

1. Disconnect the connectors by squeezing the outer ends of the receptacles and pulling apart.
2. Remove the modules from their position behind the distributor.
3. Install the modules on the shroud at the rear of the engine. Install the rectifier slightly higher and to the left of the regulator module.

NOTE: The rectifier and regulator modules are grounded to the engine frame. You will need to remove paint from the shroud to get a metal to metal contact between the base of the modules and the shroud. Do not install the modules anywhere other than on the engine.

4. Use a jumper harness (Fig. 1-31, Item 1) to connect the stator leads to the rectifier and regulator modules [A]. The keyed connectors prevent incorrect wiring.

Examine the leads for broken wires, or loose connections. If none are found, disconnect the battery and disconnect the rectifier and regulator modules from the jumper harness. Make sure the bases of the modules are making good contact with the engine shroud.

Use a ohmmeter to check for defects in the rectifier and regulator. All the checks can be completed without removing anything from the machine. If a meter connection is shown going to ground, it means engine ground. Be sure you have a good ground connection.

NOTE: If your ohmmeter does not give you the readings shown in Figures 1-32 thru 1-41, reverse the leads going into your meter. If the readings still differ from the readings listed, replace the part tested.

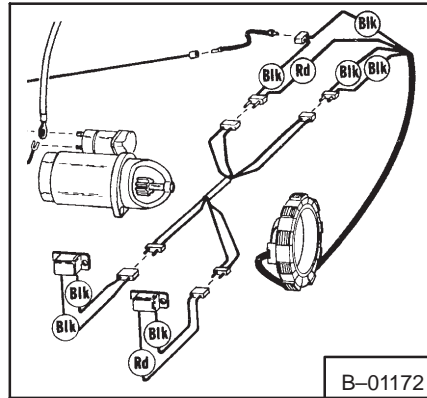

Fig. 1-31 Wiring Diagram

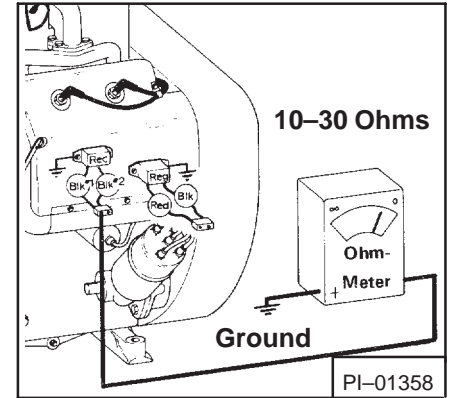

Fig. 1-32 Rectifier Check #1

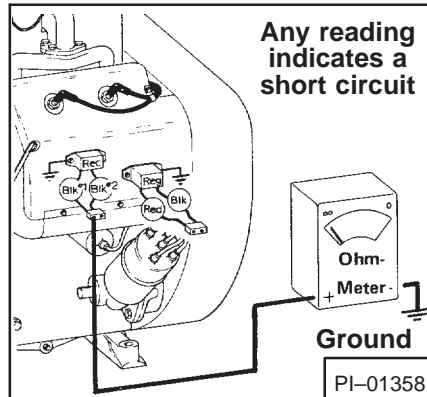

Fig. 1-33 Rectifier Check #2

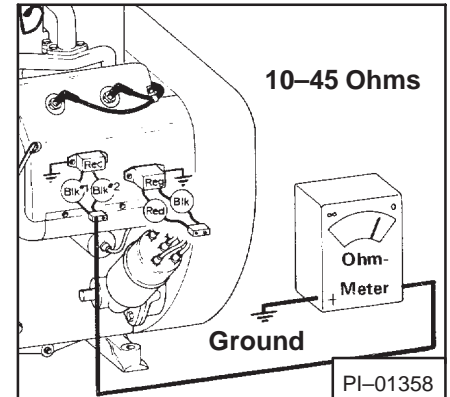

Fig. 1-34 Rectifier Check #3

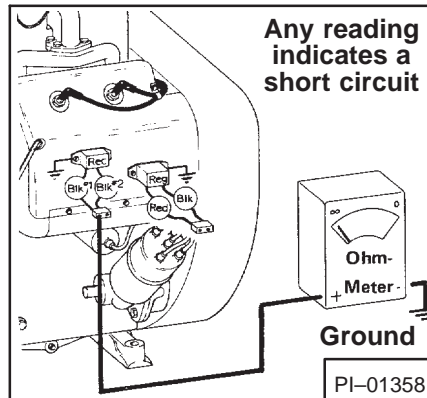

Fig. 1-35 Rectifier Check #4

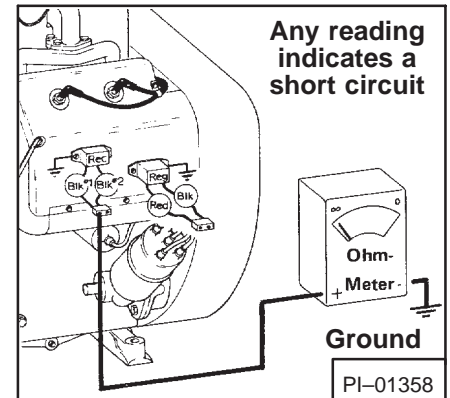

Fig. 1-36 Regulator Check #1

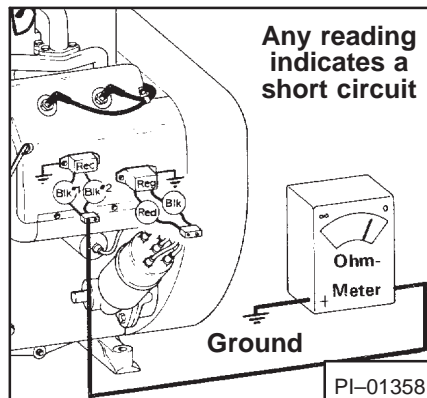

Fig. 1-37 Regulator Check #2

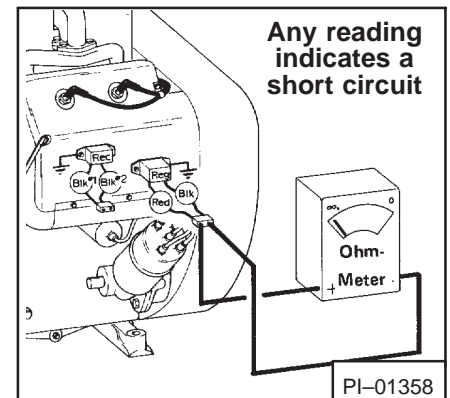

Fig. 1-38 Regulator Check #3

STATOR CHECKS

Use a test light (or continuity tester) to check for shorts from the stator leads to ground. The test light will give indication of any shorts by illuminating the bulb. If the bulb indicating there is a short, the stator will need show that replacement. If the bulb does not illuminate when checking any of the stator leads to ground, check to make sure there is continuous circuit, go onto the voltage check. Use a voltmeter to check the stator. Run the engine at full RPM when taking these readings.

NOTE: The voltmeter readings can be different from the ones shown in Figures 1-42 thru 1-46. Use the reading given only as a guide.

If the stator is bad the readings will be a lot different from the readings shown. They will be lower readings.

NOTE: If the engine is not run at full RPM the readings can be different.

If all checks are made and all readings are acceptable, but the battery doesn't charge, there is probably a bad connection in the wiring harness or the battery terminal.

NOTE: The blue wire, as referred to in these tests, is the wire next to the red wire. It is blue coming off the stator, but can be any color next to the connector.

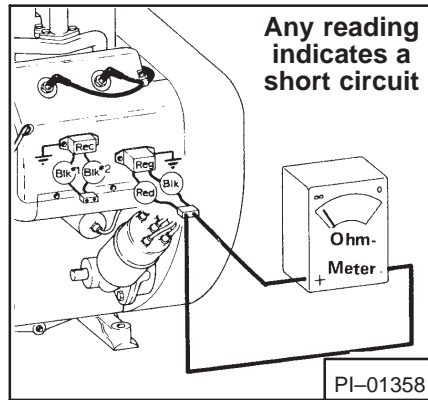

Fig. 1-39 Regulator Check #4

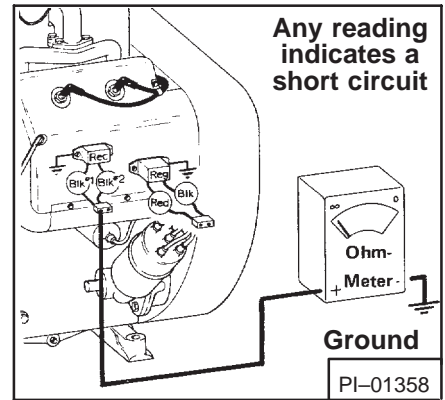

Fig. 1-40 Regulator Check #5

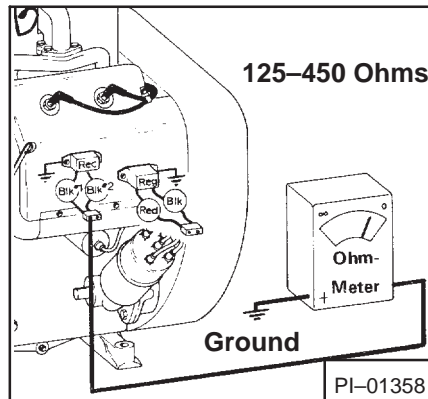

Fig. 1-41 Regulator Check #6

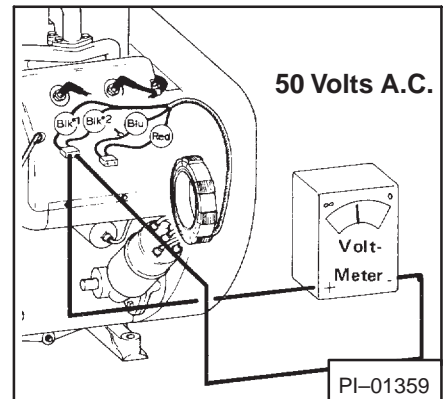

Fig. 1-42 Stator Check #1

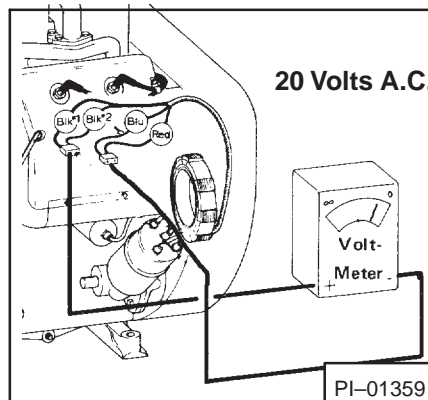

Fig. 1-43 Stator Check #2

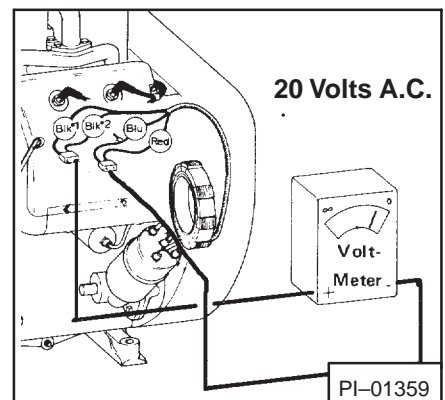

Fig. 1-44 Stator Check #3

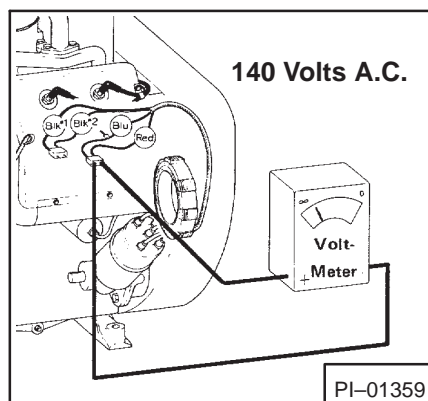

Fig. 1-45 Stator Check #4

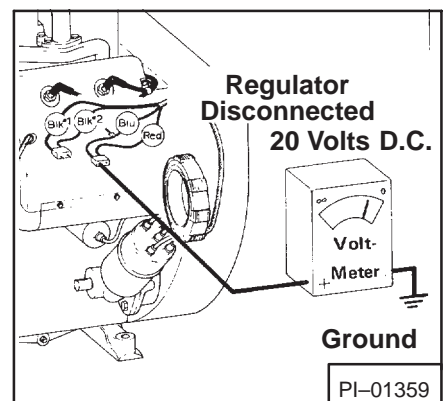

Fig. 1-46 Stator Check #5

ALTERNATOR CHECK

The following test can be made with the alternator in the machine. Disconnect all wires from the alternator except the ground wire. Connect a jumper wire from the field connector to the battery connector. Also connect a voltmeter and ammeter into the circuit as shown in the wiring diagram (Fig. 1-48).

With the engine at full RPM and a carbon pile rheostat (equivalent to 25 amp. current draw) connected across the battery, the alternator must give an output of at least 14 amps (maximum rated output is 22 amps). If the alternator does not give at least 14 amps, it is defective and should be serviced at an authorized Delco-Remy Service Center.

If the alternator charging rate is within limits, but the battery is still undercharged or overcharged, the following voltage regulator tests should be made.

NOTE: An overcharged battery condition is usually indicated by the battery using an excessive amount of water, or by being hot on top.

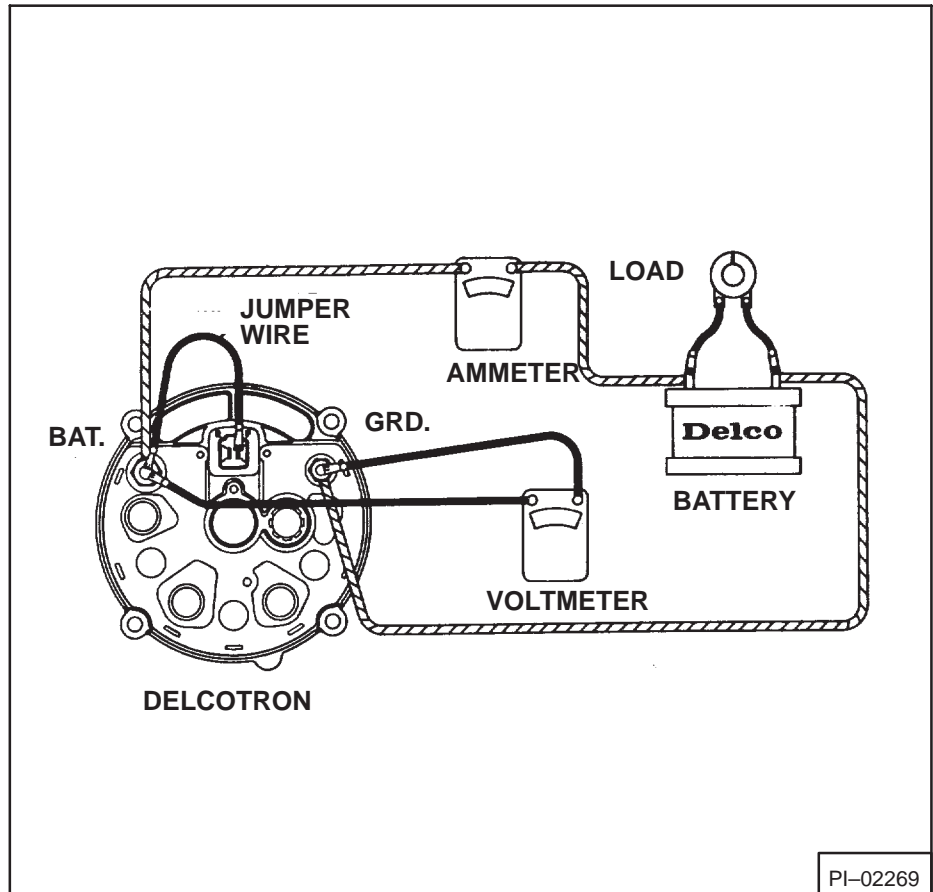

Fig. 1-48 Alternator Check

REGULATOR CHECK #1

Use a 12 volt test light. Fasten one wire of test light to #3 connector on the regulator and fasten the other end to ground. The test light must come on. If the light does not come on, there is an open circuit between the battery and #3 connector.

REGULATOR CHECK #2

Connect the voltmeter red lead (positive) to the #2 terminal on the regulator. Connect the voltmeter black lead (ground) to the base of the regulator (Fig. 1-50). The ignition switch must be turned on. The voltmeter must show 12 to 14 volts. If the voltmeter shows a very low or zero reading the circuit is open between #2 terminal on the regulator and the ignition switch and the wiring must be replaced.

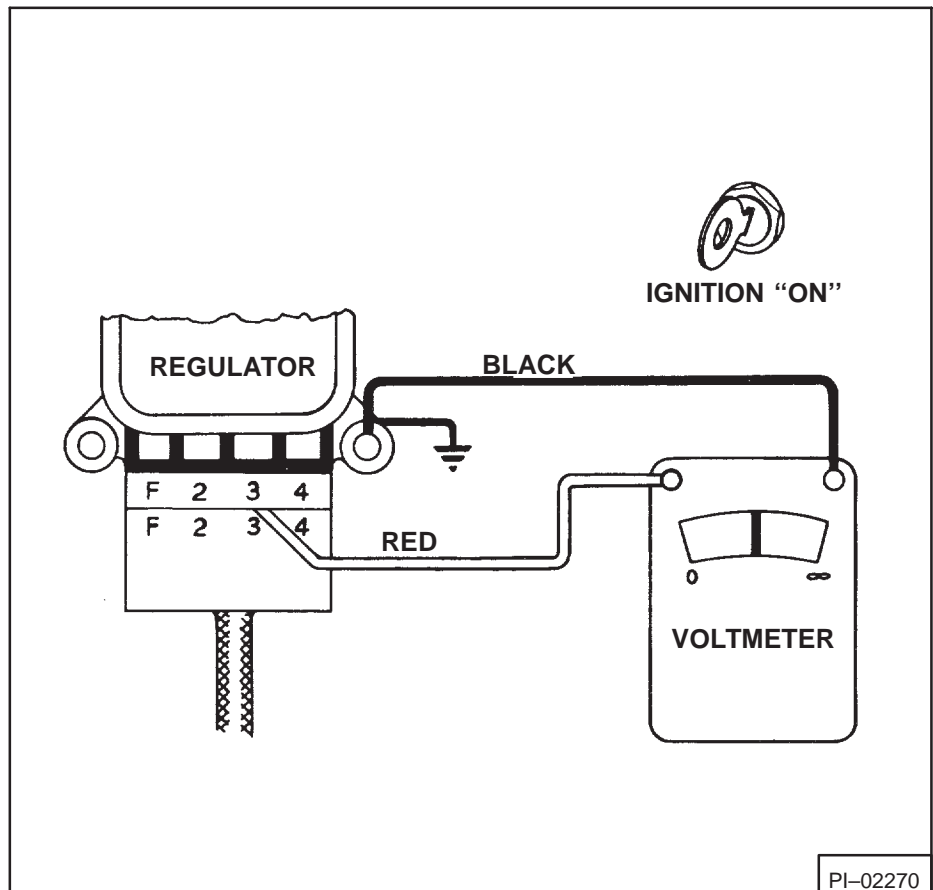

Fig. 1-49 Regulator Check #1

A 12 volt test light can also be used. Connect one wire of the test light to #2 terminal on the regulator and connect the other wire to the regulator base (ground). With the ignition switch on, the test light must come on. If it does not, the circuit is open between #2 terminal and the ignition switch. A noise will be heard whenever the #2 wire leading to the regulator is disconnected or reconnected. The noise is caused from the contact points opening and closing.

REGULATOR CHECK #3

Disconnect the wire leading to the F (field) terminal on the regulator. Connect the read wire (positive) of a voltmeter to the F (field) connector on the regulator. Connect the black wire (ground) to the regulator base (Fig. 1-51). The ignition switch must be turned on. A zero reading is an indication that the contact closing voltage setting is incorrect and the regulator unit must be adjusted or replaced.

A 12 volt test light can also be used. Connect one wire to the F terminal on the regulator. Connect the other wire to the regulator base (ground). The ignition switch must be on. The test light must come on if the light does not come on, adjust the voltage setting or replace the regulator.

If the battery is undercharged and has low voltage, the upper contacts in the voltage regulator are closing too soon.

If the battery is overcharged and losing water because of too high a charging rate, the upper contacts in the voltage regulator are not closing soon enough.

If either condition exists, have the regulator adjusted to specifications at an authorized Delco-Remy Service Center.

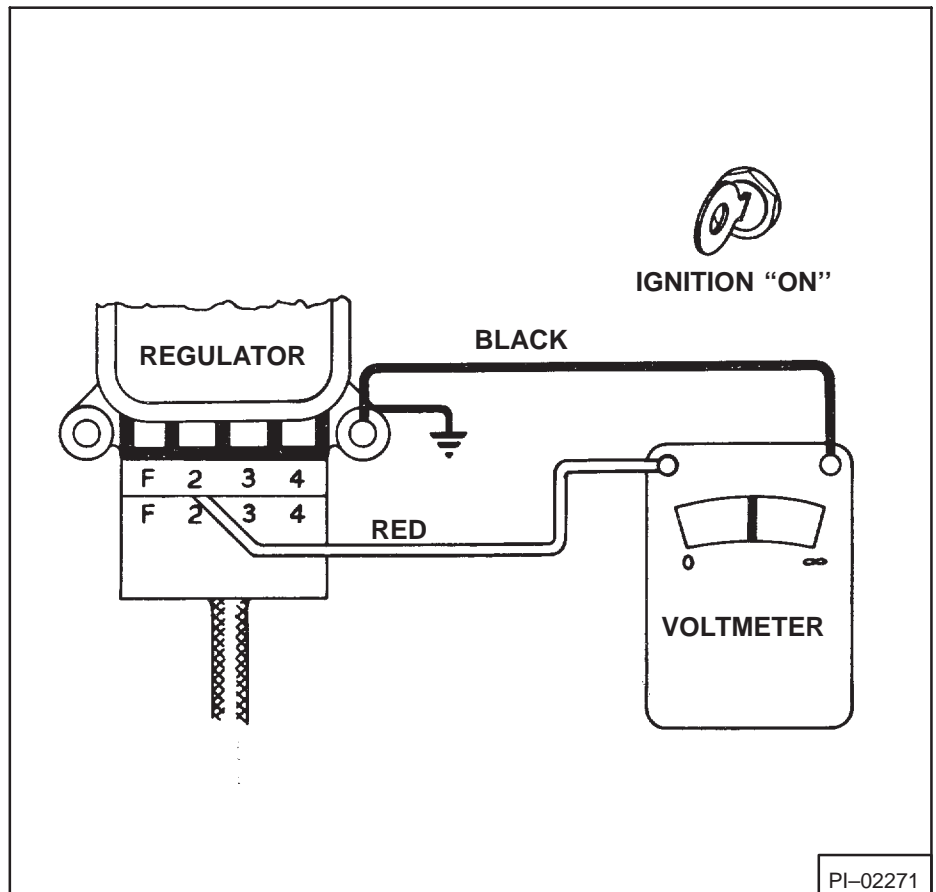

Fig. 1-50 Regulator Check #2

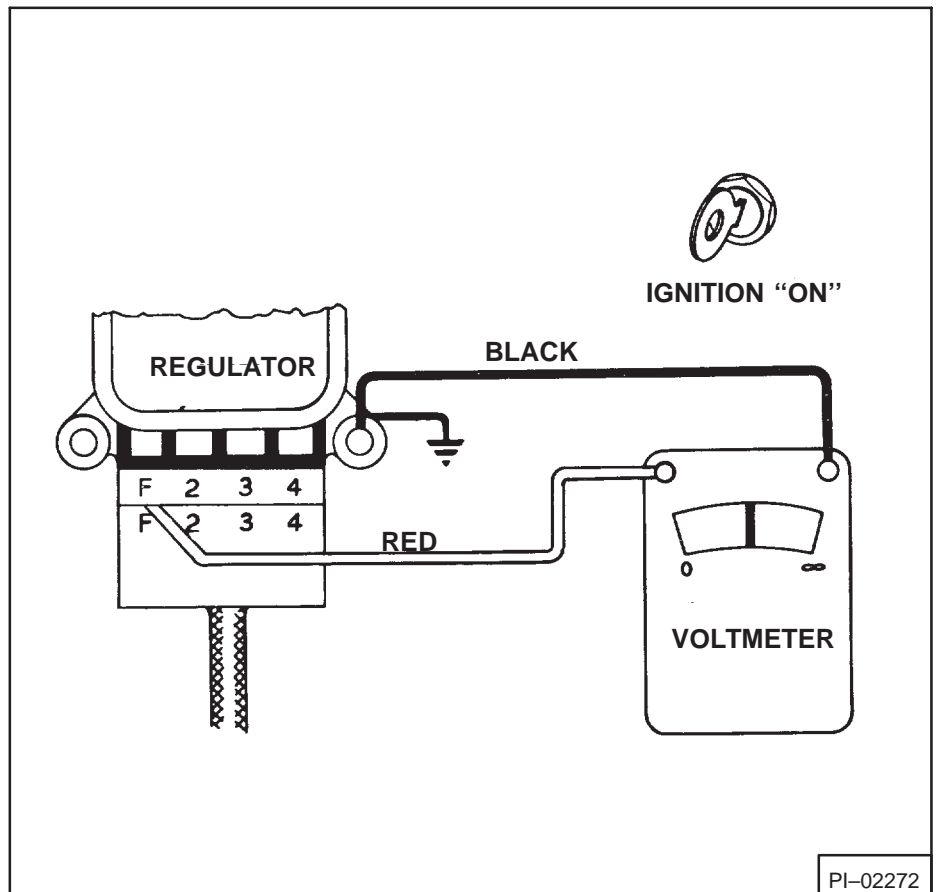

Fig. 1-51 Regulator Check #3



Suggest:

If the above button click is invalid.

Please download this document

first, and then click the above link

to download the complete manual.

Thank you so much for reading

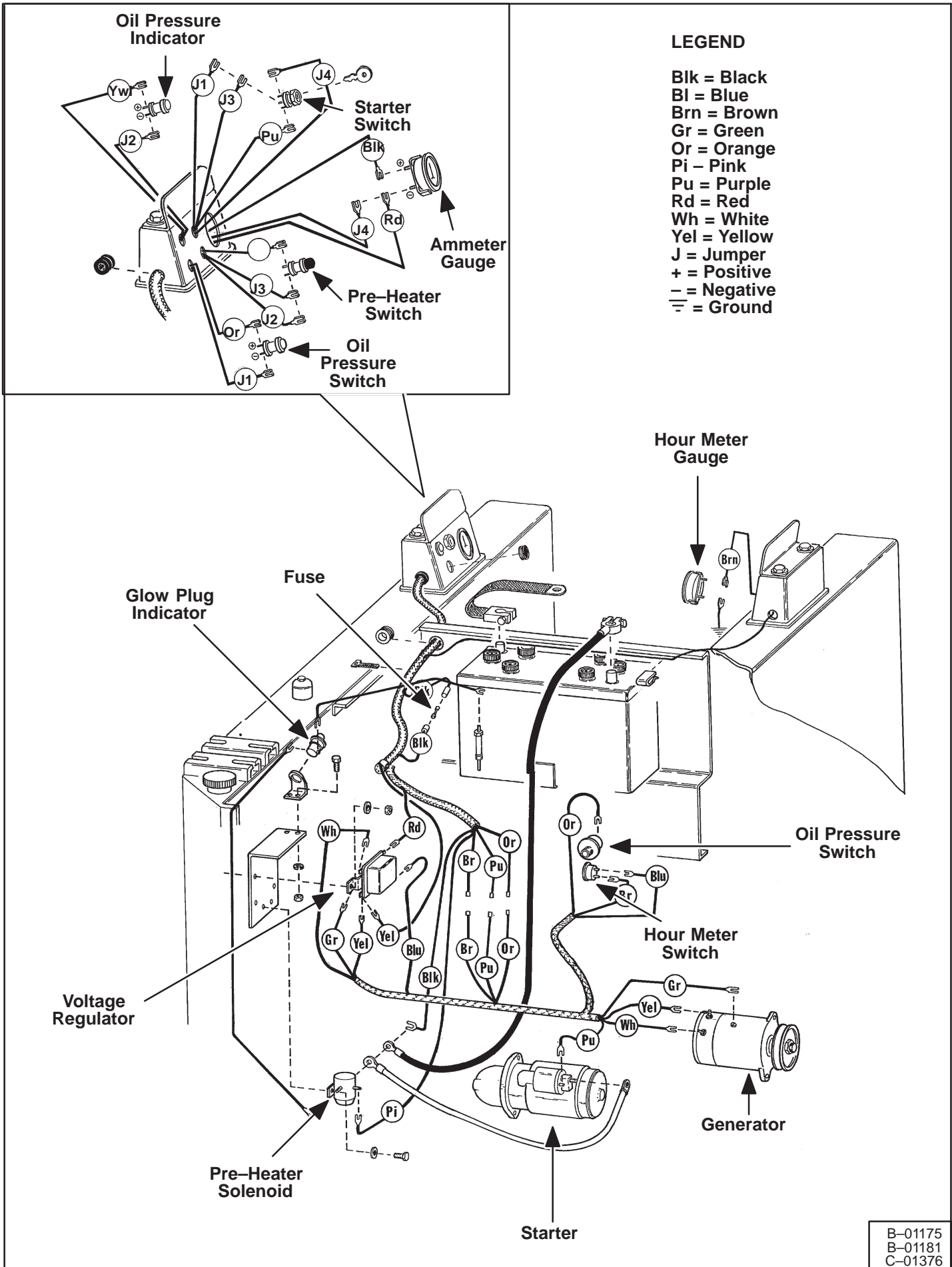

Fig. 1-52 Electrical Circuitry (Deutz W/Generator)
(Added 1-78)

B-01175
B-01181
C-01376

<https://www.ebooklibonline.com>

Hello dear friend!

Thank you very much for reading.

Enter the link into your browser.

The full manual is available for immediate download.

<https://www.ebooklibonline.com>