

Rowtrac™ 370 / 420 / 470 / 500
Steiger® 370 / 420 / 470 / 500 / 540 / 580 / 620
Quadtrac® 470 / 500 / 540 / 580 / 620
Tractor
PIN ZFF308001 and above

SERVICE MANUAL

Part number 47924544
1st edition English
October 2015
© 2015 CNH Industrial America LLC. All Rights Reserved.



Link Product / Engine

Product	Market Product	Engine
QuadTrac® 470 Quadtrac® [ZFF308001 -]	Europe	F3HFE613D*B001
QuadTrac® 540 Quadtrac® [ZFF308001 -]	Europe	F3DFE613J*B001
QuadTrac® 540 Quadtrac® scraper [ZFF308001 -]	Europe	F3DFE613J*B001
QuadTrac® 580 Quadtrac® [ZFF308001 -]	Europe	F3DFE613G*B001
QuadTrac® 580 Quadtrac® scraper [ZFF308001 -]	Europe	F3DFE613G*B001
QuadTrac® 620 Quadtrac® [ZFF308001 -]	Europe	F3DFE613F*B001
Steiger® 370 Heavy duty wheeled [ZFF308001 -]	Europe	F2CFE614A*B
Steiger® 420 Heavy duty wheeled [ZFF308001 -]	Europe	F3HFE613G*B001
Steiger® 470 Heavy duty wheeled [ZFF308001 -]	Europe	F3HFE613D*B001
Steiger® 470 Wheeled scraper [ZFF308001 -]	Europe	F3HFE613D*B001
Steiger® 500 Heavy duty wheeled [ZFF308001 -]	Europe	F3HFE613B*B001
Steiger® 500 Wheeled scraper [ZFF308001 -]	Europe	F3HFE613B*B001
Steiger® 500 QT Quadtrac® [ZFF308001 -]	Europe	F3HFE613B*B001
Steiger® 500 QT Quadtrac® scraper [ZFF308001 -]	Europe	F3HFE613B*B001
Steiger® 540 Heavy duty wheeled [ZFF308001 -]	Europe	F3DFE613J*B001
Steiger® 540 Wheeled scraper [ZFF308001 -]	Europe	F3DFE613J*B001
Steiger® 580 Heavy duty wheeled [ZFF308001 -]	Europe	F3DFE613G*B001
Steiger® 580 Wheeled scraper [ZFF308001 -]	Europe	F3DFE613G*B001
Steiger® 620 Heavy duty wheeled [ZFF308001 -]	Europe	F3DFE613F*B001
Steiger® 620 Wheeled scraper [ZFF308001 -]	Europe	F3DFE613F*B001

Contents

INTRODUCTION

Engine	10
[10.001] Engine and crankcase	10.1
[10.216] Fuel tanks	10.2
[10.202] Air cleaners and lines	10.3
[10.310] Aftercooler.....	10.4
[10.400] Engine cooling system	10.5
[10.414] Fan and drive	10.6
[10.500] Selective Catalytic Reduction (SCR) exhaust treatment.....	10.7
Power coupling	19
[19.110] Flywheel damper	19.1
Transmission	21
[21.113] Powershift transmission	21.1
[21.135] Powershift transmission external controls.....	21.2
[21.155] Powershift transmission internal components.....	21.3
Front axle system	25
[25.100] Powered front axle	25.1
[25.102] Front bevel gear set and differential	25.2
[25.310] Final drives	25.3
Rear axle system	27
[27.100] Powered rear axle.....	27.1
[27.106] Rear bevel gear set and differential	27.2
[27.120] Planetary and final drives	27.3
Power Take-Off (PTO)	31
[31.104] Rear electro-hydraulic control.....	31.1
[31.110] One-speed rear Power Take-Off (PTO)	31.2

<https://www.ebooklibonline.com>

Hello dear friend!

Thank you very much for reading.

Enter the link into your browser.

The full manual is available for immediate download.

<https://www.ebooklibonline.com>

[31.220] Gearbox	31.3
Brakes and controls	33
[33.110] Parking brake or parking lock	33.1
[33.202] Hydraulic service brakes	33.2
Hydraulic systems.....	35
[35.000] Hydraulic systems.....	35.1
[35.102] Pump control valves.....	35.2
[35.105] Charge pump.....	35.3
[35.106] Variable displacement pump	35.4
[35.204] Remote control valves	35.5
[35.220] Auxiliary hydraulic pump and lines	35.6
[35.300] Reservoir, cooler, and filters.....	35.7
[35.304] Combination pump units	35.8
[35.600] High flow hydraulics	35.9
Hitches, drawbars, and implement couplings.....	37
[37.100] Drawbars and towing hitches	37.1
Frames and ballasting	39
[39.100] Frame	39.1
[39.110] Drawbar and hitch assembly	39.2
Steering.....	41
[41.101] Steering control	41.1
[41.200] Hydraulic control components.....	41.2
[41.206] Pump	41.3
Wheels	44
[44.511] Front wheels.....	44.1
[44.520] Rear wheels.....	44.2
Tracks and track suspension	48

[48.100] Tracks	48.1
[48.130] Track frame and driving wheels	48.2
[48.134] Track tension units	48.3
[48.138] Track rollers	48.4
Cab climate control	50
[50.104] Ventilation	50.1
[50.200] Air conditioning	50.2
[50.300] Cab pressurizing system	50.3
Electrical systems	55
[55.000] Electrical system	55.1
[55.100] Harnesses and connectors	55.2
[55.301] Alternator	55.3
[55.302] Battery	55.4
[55.010] Fuel injection system	55.5
[55.014] Engine intake and exhaust system	55.6
[55.024] Transmission control system	55.7
[55.045] Front axle control system	55.8
[55.046] Rear axle control system	55.9
[55.048] Rear Power Take-Off (PTO) control system	55.10
[55.050] Heating, Ventilation, and Air-Conditioning (HVAC) control system	55.11
[55.051] Cab Heating, Ventilation, and Air-Conditioning (HVAC) controls	55.12
[55.404] External lighting	55.13
[55.522] Cab Power Take-Off (PTO) controls	55.14
[55.640] Electronic modules	55.15
[55.035] Remote control valve electric control	55.16
[55.130] Rear three-point hitch electronic control system	55.17
[55.988] Selective Catalytic Reduction (SCR) electrical system	55.18
[55.DTC] FAULT CODES	55.19

Platform, cab, bodywork, and decals	90
[90.100] Engine hood and panels	90.1
[90.102] Engine shields, hood latches, and trims	90.2
[90.124] Pneumatically-adjusted operator seat.....	90.3
[90.150] Cab.....	90.4
[90.151] Cab interior.....	90.5



INTRODUCTION

Foreword - Important notice regarding equipment servicing

STEIGER®	
----------	--

All repair and maintenance work listed in this manual must be carried out only by qualified dealership personnel, strictly complying with the instructions given, and using, whenever possible, the special tools.

Anyone who performs repair and maintenance operations without complying with the procedures provided herein shall be responsible for any subsequent damages.

The manufacturer and all the organizations of its distribution chain, including - without limitation - national, regional, or local dealers, reject any responsibility for damages caused by parts and/or components not approved by the manufacturer, including those used for the servicing or repair of the product manufactured or marketed by the manufacturer. In any case, no warranty is given or attributed on the product manufactured or marketed by the manufacturer in case of damages caused by parts and/or components not approved by the manufacturer.

The manufacturer reserves the right to make improvements in design and changes in specifications at any time without notice and without incurring any obligation to install them on units previously sold. Specifications, descriptions, and illustrative material herein are as accurate as known at time of publication but are subject to change without notice.

In case of questions, refer to your CASE IH Sales and Service Networks.

Safety rules

STEIGER®

Personal safety





This is the safety alert symbol. It is used to alert you to potential personal injury hazards. Obey all safety messages that follow this symbol to avoid possible death or injury.

Throughout this manual you will find the signal words DANGER, WARNING, and CAUTION followed by special instructions. These precautions are intended for the personal safety of you and those working with you.

Read and understand all the safety messages in this manual before you operate or service the machine.

 DANGER indicates a hazardous situation that, if not avoided, will result in death or serious injury.

 WARNING indicates a hazardous situation that, if not avoided, could result in death or serious injury.

 CAUTION indicates a hazardous situation that, if not avoided, could result in minor or moderate injury.

FAILURE TO FOLLOW DANGER, WARNING, AND CAUTION MESSAGES COULD RESULT IN DEATH OR SERIOUS INJURY.

Machine safety

NOTICE: Notice indicates a situation that, if not avoided, could result in machine or property damage.

Throughout this manual you will find the signal word Notice followed by special instructions to prevent machine or property damage. The word Notice is used to address practices not related to personal safety.

Information

NOTE: Note indicates additional information that clarifies steps, procedures, or other information in this manual.

Throughout this manual you will find the word Note followed by additional information about a step, procedure, or other information in the manual. The word Note is not intended to address personal safety or property damage.

Safety rules - Ecology and the environment

STEIGER®

Soil, air, and water quality is important for all industries and life in general. When legislation does not yet rule the treatment of some of the substances that advanced technology requires, sound judgment should govern the use and disposal of products of a chemical and petrochemical nature.

Familiarize yourself with the relative legislation applicable to your country, and make sure that you understand this legislation. Where no legislation exists, obtain information from suppliers of oils, filters, batteries, fuels, anti-freeze, cleaning agents, etc., with regard to the effect of these substances on man and nature and how to safely store, use, and dispose of these substances.

Helpful hints

- Avoid the use of cans or other inappropriate pressurized fuel delivery systems to fill tanks. Such delivery systems may cause considerable spillage.
- In general, avoid skin contact with all fuels, oils, acids, solvents, etc. Most of these products contain substances that may be harmful to your health.
- Modern oils contain additives. Do not burn contaminated fuels and or waste oils in ordinary heating systems.
- Avoid spillage when you drain fluids such as used engine coolant mixtures, engine oil, hydraulic fluid, brake fluid, etc. Do not mix drained brake fluids or fuels with lubricants. Store all drained fluids safely until you can dispose of the fluids in a proper way that complies with all local legislation and available resources.
- Do not allow coolant mixtures to get into the soil. Collect and dispose of coolant mixtures properly.
- The air-conditioning system contains gases that should not be released into the atmosphere. Consult an air-conditioning specialist or use a special extractor to recharge the system properly.
- Repair any leaks or defects in the engine cooling system or hydraulic system immediately.
- Do not increase the pressure in a pressurized circuit as this may lead to a component failure.
- Protect hoses during welding. Penetrating weld splatter may burn a hole or weaken hoses, allowing the loss of oils, coolant, etc.

Battery recycling

Batteries and electric accumulators contain several substances that can have a harmful effect on the environment if the batteries are not properly recycled after use. Improper disposal of batteries can contaminate the soil, groundwater, and waterways. CASE IH strongly recommends that you return all used batteries to a CASE IH dealer, who will dispose of the used batteries or recycle the used batteries properly. In some countries, this is a legal requirement.



Mandatory battery recycling

NOTE: *The following requirements are mandatory in Brazil.*

Batteries are made of lead plates and a sulfuric acid solution. Because batteries contain heavy metals such as lead, CONAMA Resolution 401/2008 requires you to return all used batteries to the battery dealer when you replace any batteries. Do not dispose of batteries in your household garbage.

Points of sale are obliged to:

- Accept the return of your used batteries
- Store the returned batteries in a suitable location
- Send the returned batteries to the battery manufacturer for recycling



SERVICE MANUAL

Engine

QuadTrac® 470 Quadtrac® [ZFF308001 -], QuadTrac® 540 Quadtrac® [ZFF308001 -], QuadTrac® 540 Quadtrac® scraper [ZFF308001 -], QuadTrac® 580 Quadtrac® [ZFF308001 -], QuadTrac® 580 Quadtrac® scraper [ZFF308001 -], QuadTrac® 620 Quadtrac® [ZFF308001 -], Steiger® 370 Heavy duty wheeled [ZFF308001 -], Steiger® 420 Heavy duty wheeled [ZFF308001 -], Steiger® 470 Heavy duty wheeled [ZFF308001 -], Steiger® 470 Wheeled scraper [ZFF308001 -], Steiger® 500 Heavy duty wheeled [ZFF308001 -], Steiger® 500 QT Quadtrac® [ZFF308001 -], Steiger® 500 QT Quadtrac® scraper [ZFF308001 -], Steiger® 500 Wheeled scraper [ZFF308001 -], Steiger® 540 Heavy duty wheeled [ZFF308001 -], Steiger® 540 Wheeled scraper [ZFF308001 -], Steiger® 580 Heavy duty wheeled [ZFF308001 -], Steiger® 580 Wheeled scraper [ZFF308001 -], Steiger® 620 Heavy duty wheeled [ZFF308001 -], Steiger® 620 Wheeled scraper [ZFF308001 -]

Engine - Change fluid - Changing engine oil and filter

STEIGER®

NOTE: Reduce to 300 hours or less if **CASE IH AKCELA UNITEK NO. 1™ SBL CJ-4** is not used.

Change the engine oil and filter every 600 hours or once a year or before storage, whichever occurs first. Your dealer has approved oil and filters. Do not use other types of oil or filters.

NOTE: For best results change the oil and filter while the engine is still warm to the touch from operation (not hot). The tractor must be on a level surface.

Remove the engine side shields.

9L engine

1. Remove the oil pan drain plug and drain the oil from the engine into a container.
2. After all oil has drained, install new washer 98474302 on drain plug, center washer on plug and install drain plug. Torque drain plug to **30 N·m (22 lb ft)**.
3. Clean the area around the filter head and housing on the left side of the engine. Place a container under the oil filter and turn the filter housing counterclockwise to loosen with a **51 mm (2 in)** wrench. After all oil has drained from the filter, remove the housing with filter.

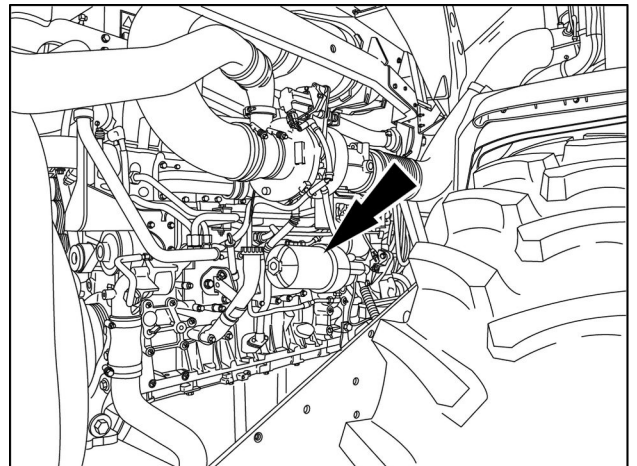

RAIL13TR04406AA 1

4. Install the new filter cartridge and O-ring. Lightly oil new O-ring.
4. Reinstall the filter assembly onto the tractor. Do not over tighten or O-ring will leak.

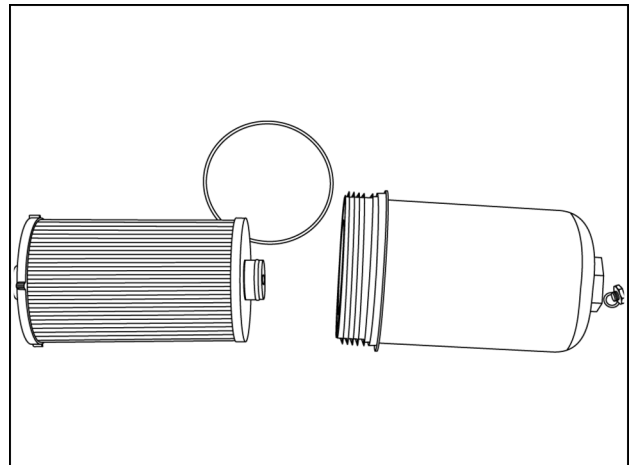

RCPH10FWD928BAM 2

5. Fill with new oil into the engine oil fill **(1)**.

NOTE: Total oil refill capacity will be determined by how completely the crankcase drains. Do not fill above the high mark on the dipstick **(2)** when refilling.

6. Operate the engine for five minutes at **1000 RPM**. Check for oil leaks at the filter base and drain plug.
7. Stop the engine. Wait approximately five minutes for the oil to return to the oil pan. Check the oil level on the dipstick **(2)** and add oil if needed.

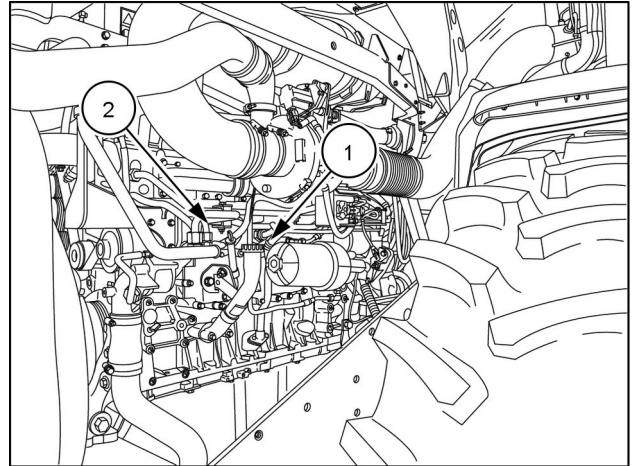

RAIL13TR0406AA 3

13L engines

1. Remove the oil pan drain plug and drain the oil from the engine into a container.
2. After all oil has drained, install new washer 98474302 on drain plug, center washer on plug and install drain plug. Torque drain plug to **30 N·m (22 lb ft)**.
3. Place a container under the oil filter on the left side of the engine. Use a **19 mm (0.75 in)** socket to open drain on bottom of housing. This will allow oil to drain from the housing. After oil is drained, turn the filter housing counterclockwise to loosen with a **51 mm (2 in)** wrench and remove the filter housing.

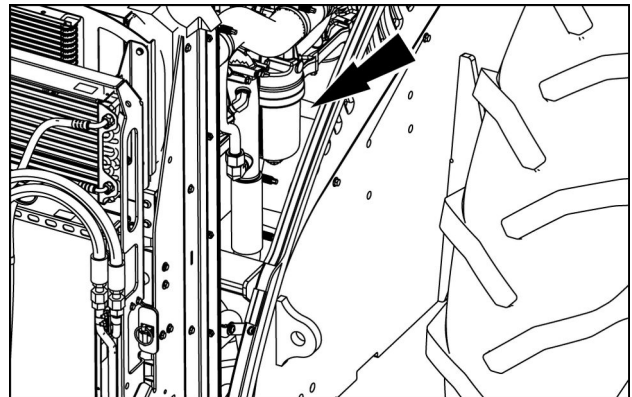

RAIL14TR00085AA 4

4. Install the new filter cartridge and O-ring.
4. Reinstall the filter assembly. Do not over tighten or the O-ring will leak.

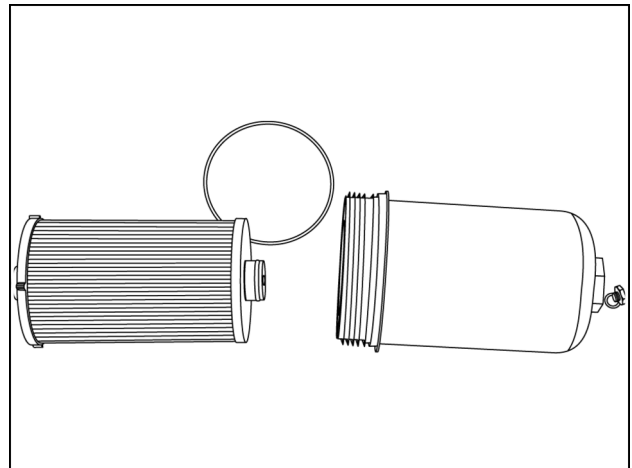

RCPH10FWD928BAM 5

5. Fill with new oil into the engine oil fill **(1)**.

NOTE: Total oil refill capacity will be determined by how completely the crankcase drains. Do not fill above the high mark on the dipstick **(2)** when refilling.

6. Operate the engine for five minutes at **1000 RPM**. Check for oil leaks at the filter base and drain plug.
7. Stop the engine. Wait approximately five minutes for the oil to return to the oil pan. Check the oil level on the dipstick **(2)** and add oil if needed.

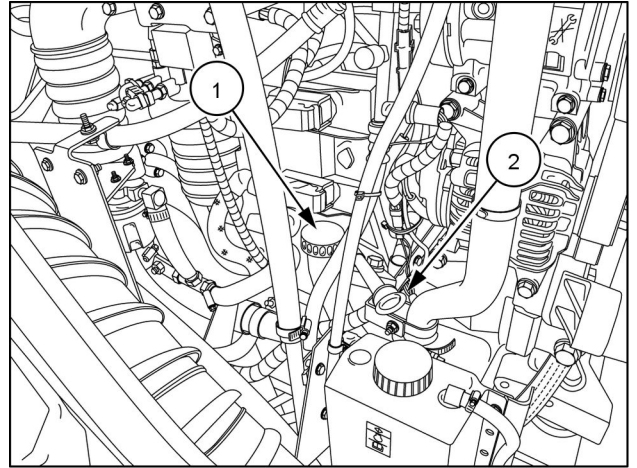

RAIL13TR01857AA 6

Engine - Remove - 9L

Steiger® 370

Prior operation:

Hood support - Remove – Row crop frame, 9L engine (90.102)

1. Disconnect the driveshaft from the engine.

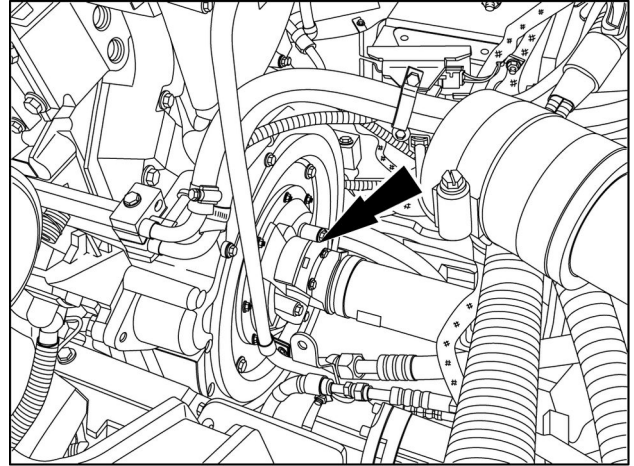

RAIL13TR02967AA 1

2. Label and disconnect the heater hoses from the tubes.

NOTE: Plug and cap all disconnected hoses and tubes.

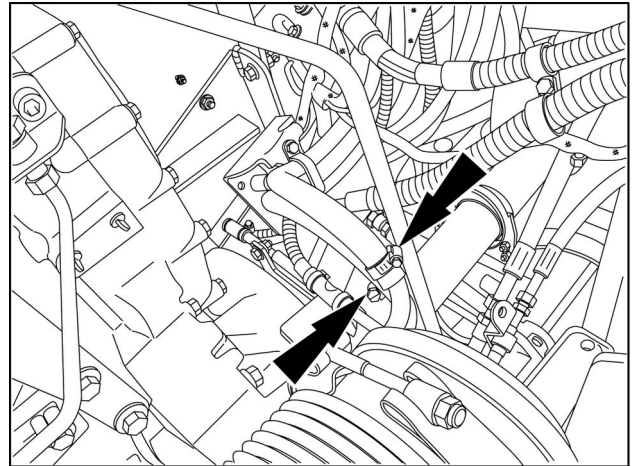

RAIL13TR02966AA 2

3. Label and disconnect the two hoses for the diesel emissions fluid tank solenoid.

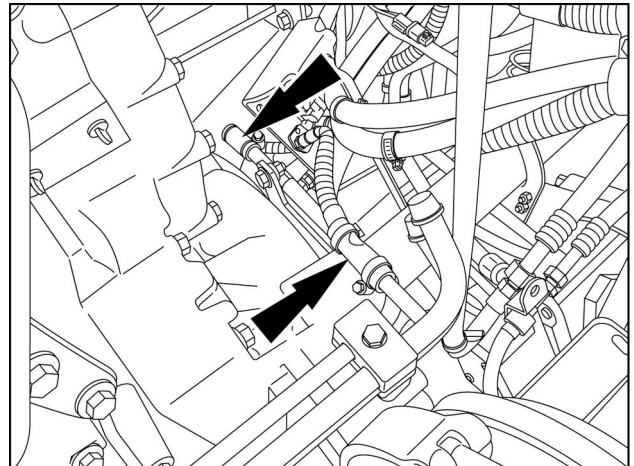

RAIL13TR02969AA 3

4. Loosen the hose clamp (1) at the turbo.
5. Remove the air intake tube (2) from the engine.

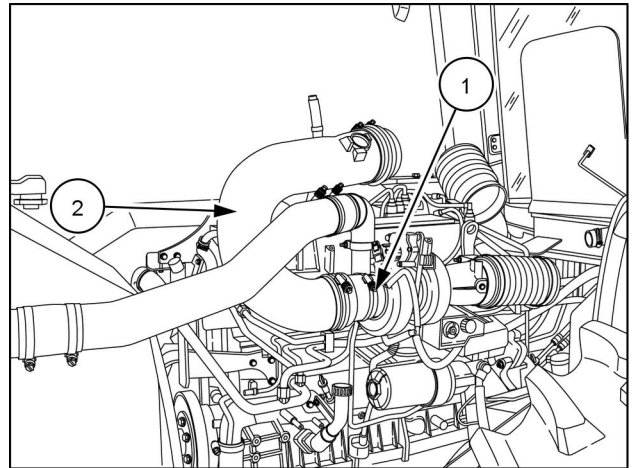

RAIL13TR03051AA 4

6. Disconnect the power cable (1) from the starter.
7. Disconnect the wire (2) from the starter.
8. Remove the bolt (3) and disconnect the ground strap from the engine block.

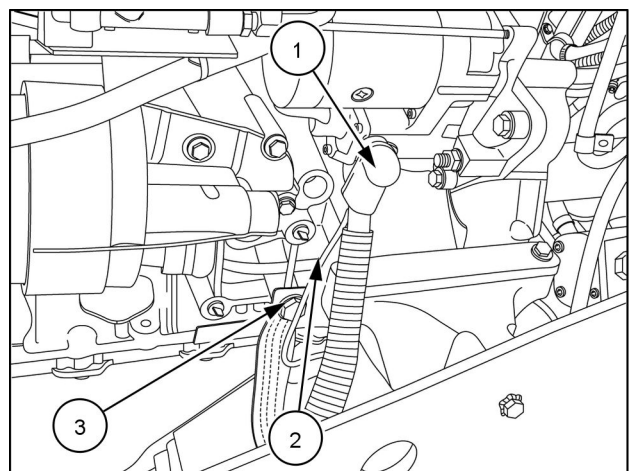

RAIL13TR02970AA 5

9. Remove the left hand charged air cooler tube.
- NOTE:** Plug and cap disconnected tubes and ports.

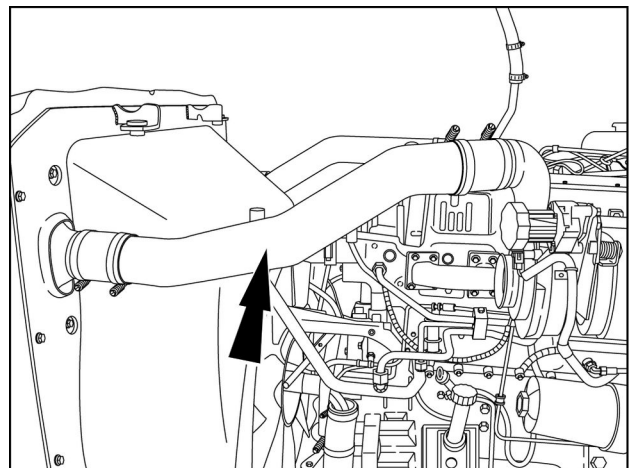

RAIL13TR02978AA 6

10. Disconnect the lower radiator hose at the engine.

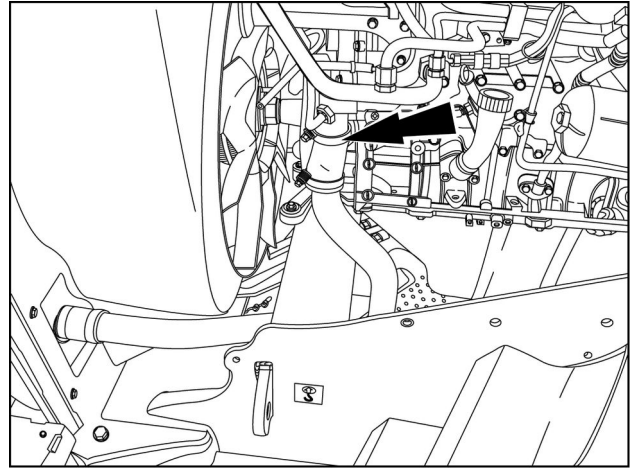

RAIL13TR02971AA 7

11. Attach a support strap to the cooling package frame and the chassis frame as shown to support the cooling package.

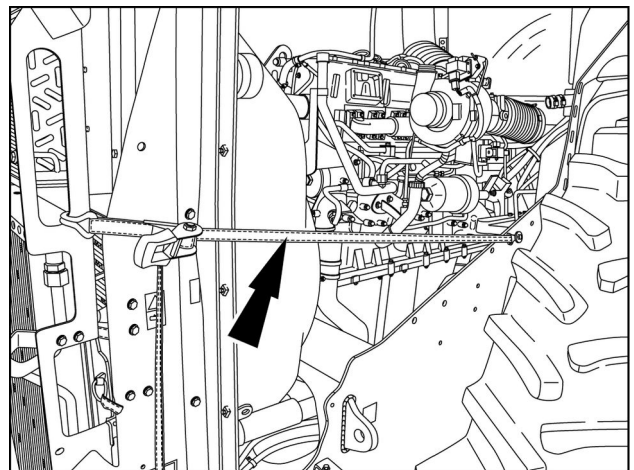

RAIL13TR02973AA 8

12. Remove the right hand charged air cooler tube.

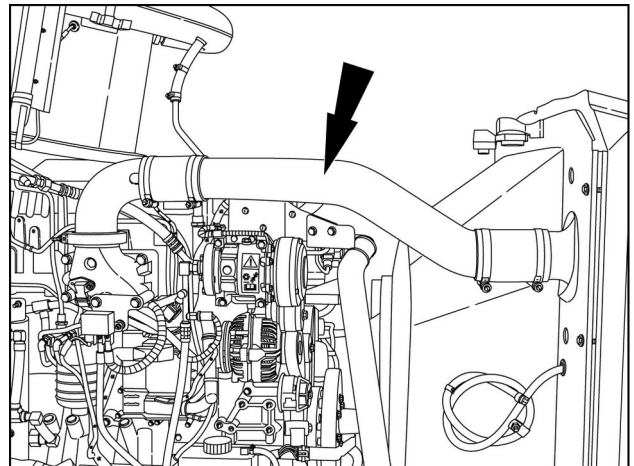

RAIL13TR02972AA 9

13. Remove the clamp **(1)** securing the upper radiator tube to the bracket on the engine.
14. Remove the upper radiator tube **(2)**.

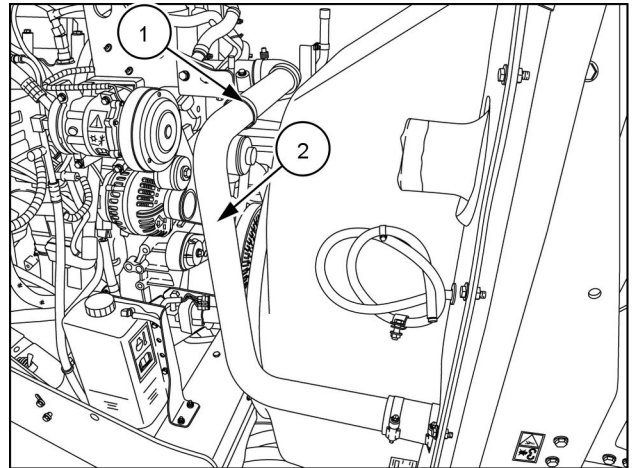

RAIL13TR02974AA 10

15. Cut the ties securing the harness and disconnect the harness.

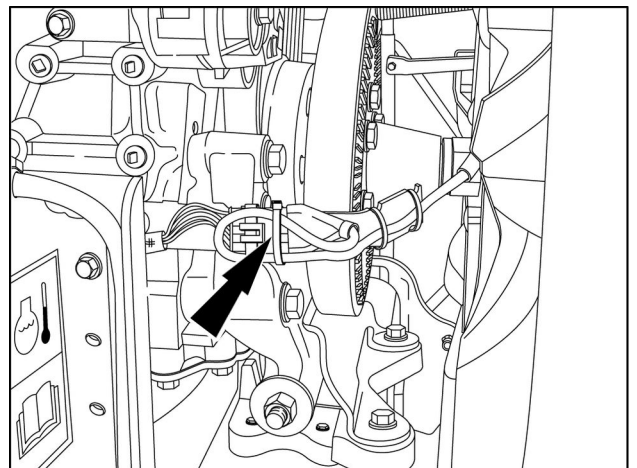

RAIL13TR02976AA 11

16. Loosen the viscous drive from the shaft.
NOTE: The fan pulley hub is left handed threaded.

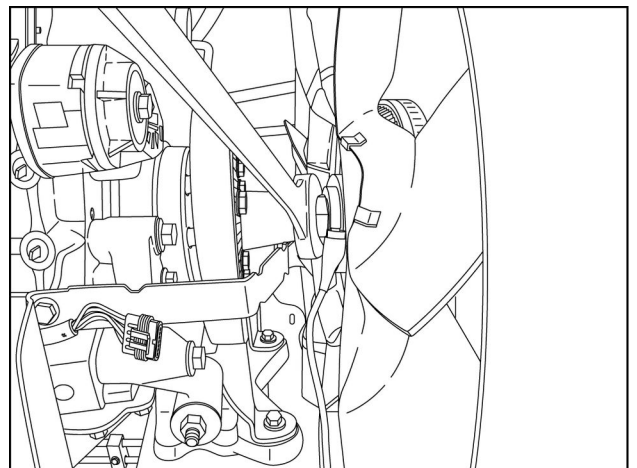

RAIL13TR02979AA 12

17. With the help of an assistant remove the fan out the right hand side of the machine.

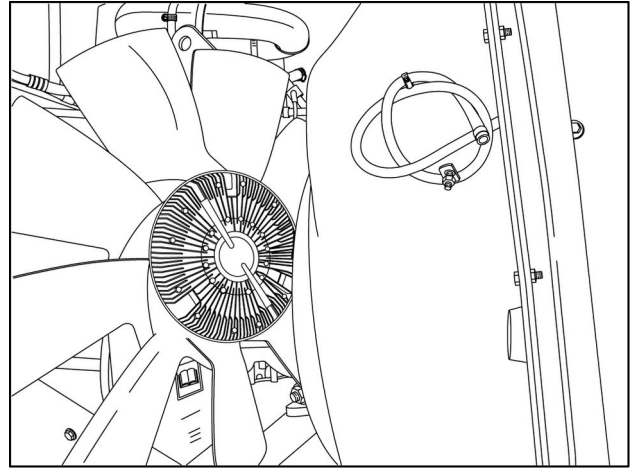

RAIL13TR02977AA 13

18. Disconnect the harness lead to the air conditioner high pressure switch (1) and the clutch activation lead (2).

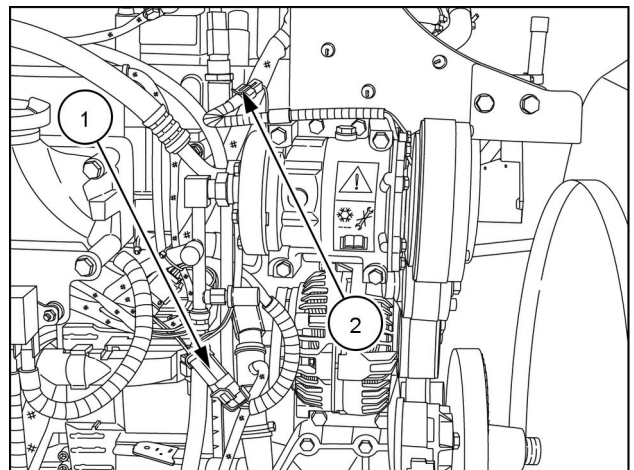

RAIL13TR02981AA 14

19. Use a breaker bar to relieve the tension on the serpentine belt and remove the belt from the air conditioner compressor pulley.

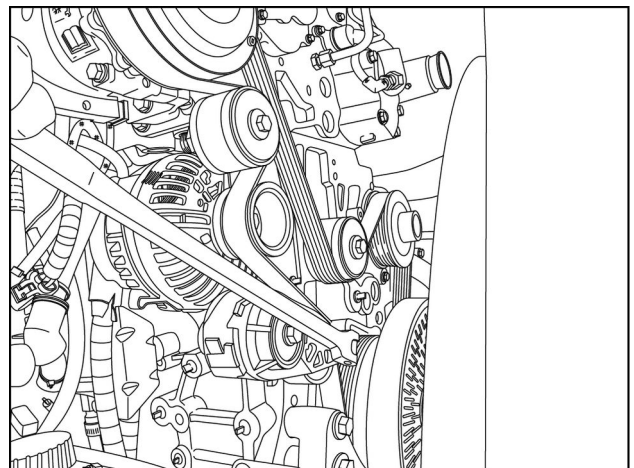

RAIL13TR02987AA 15

20. Support the compressor and remove the four mounting bolts.

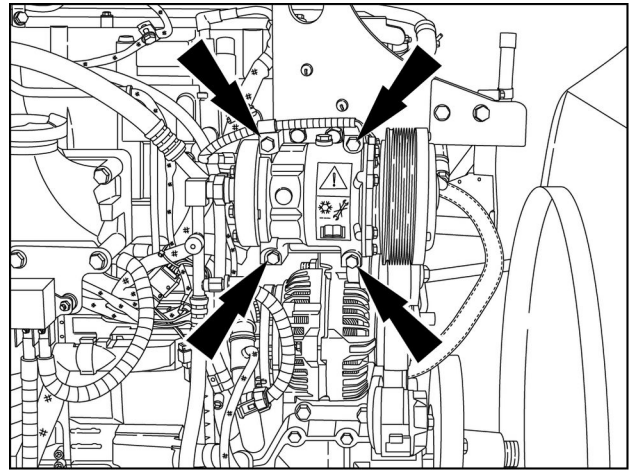

RAIL13TR02986AA 16

21. Set the compressor on the right hand front tire and secure with holding straps as shown.

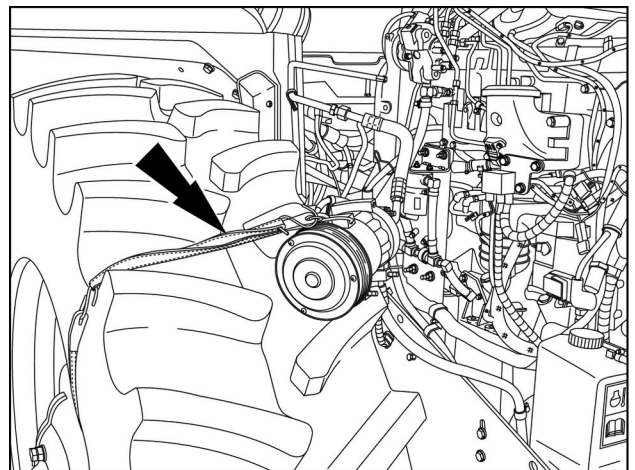

RAIL13TR02982AA 17

22. Disconnect the power cable (1) from the alternator.
23. Disconnect the exciter wire (2) from the alternator.

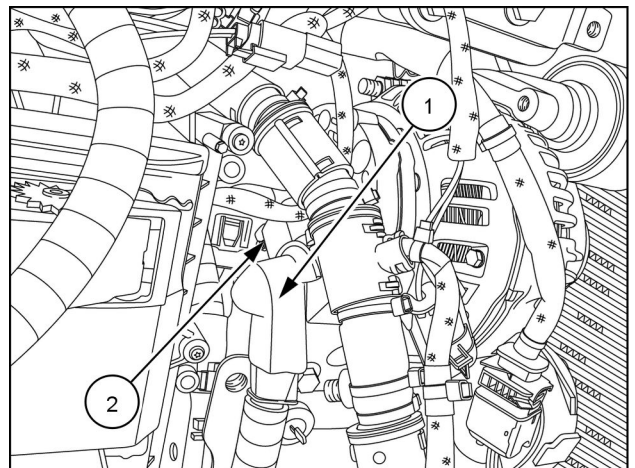

RAIL13TR02983AA 18

24. Disconnect the harness (1).
25. Remove the bolt (2) securing the harness to the engine block.

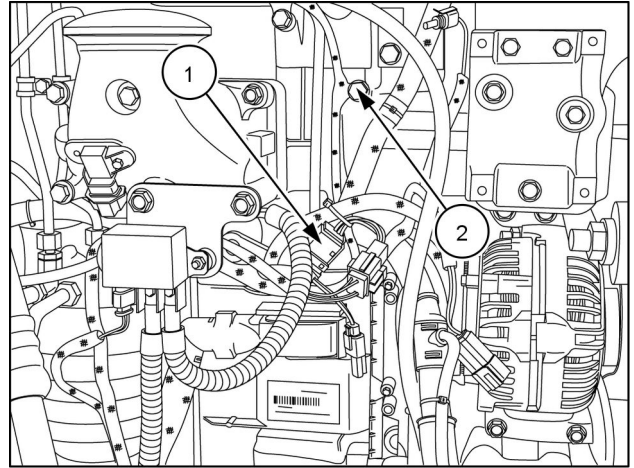

RAIL13TR02985AA 19

26. Unplug the connector (1).
27. Disconnect the main harness (2) from the engine controller.
28. Disconnect the cable (3) from the junction box.
29. Cut the tie (4) securing the harness and cable together.
30. Move the harness (5) out from behind the junction box and the engine to stay with the chassis during engine removal.

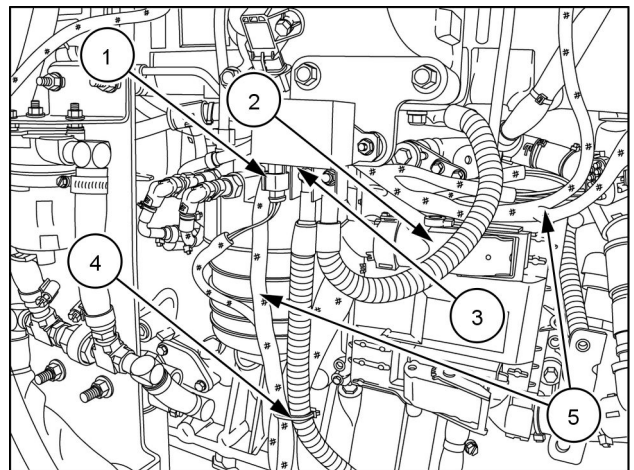

RAIL13TR02988AA 20

31. Remove the nut and bolt (1) securing the cable to the bracket.
32. Remove the bolts (2) securing the bracket to the engine block.

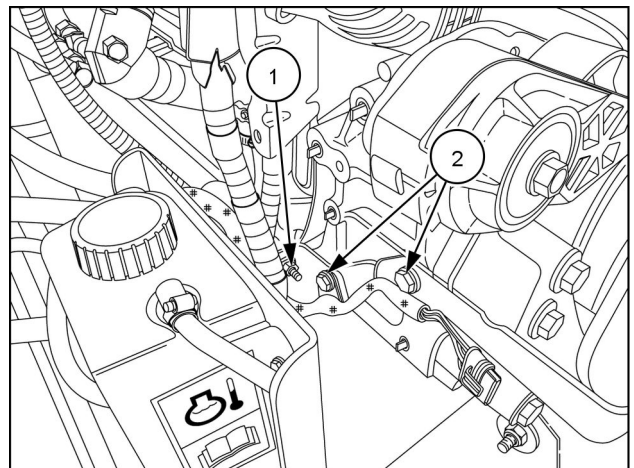

RAIL13TR02984AA 21



Suggest:

If the above button click is invalid.

Please download this document

first, and then click the above link

to download the complete manual.

Thank you so much for reading

33. Remove the bolt (1) securing the harness to the engine block.

34. Disconnect the fuel inlet hose (2).

NOTE: Plug and cap all disconnected fuel hoses and fittings.

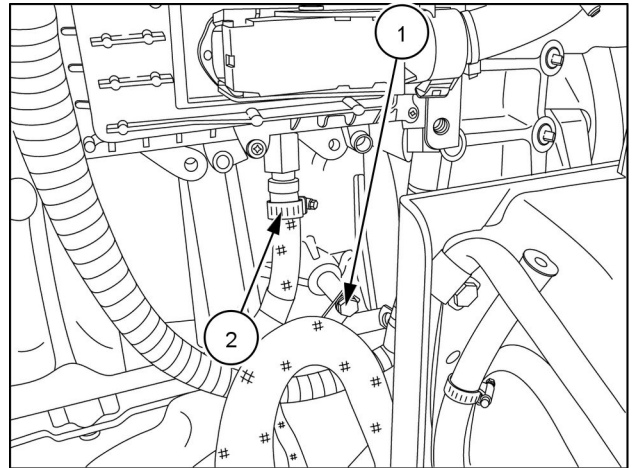

RAIL13TR02993AA 22

35. Disconnect the fuel return hose.

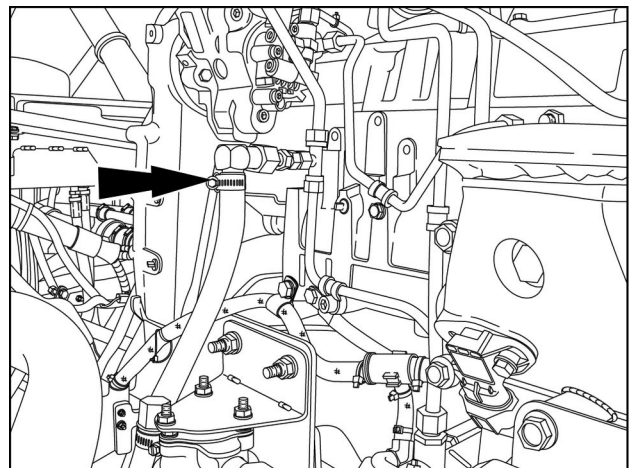

RAIL13TR02991AA 23

36. Remove the right and left hand hold down brackets.

NOTE: Left hand side is shown. Remove both sides.

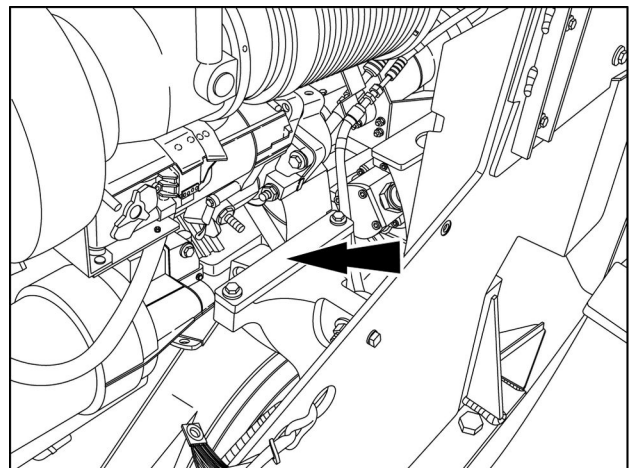

RAIL13TR02989AA 24

<https://www.ebooklibonline.com>

Hello dear friend!

Thank you very much for reading.

Enter the link into your browser.

The full manual is available for immediate download.

<https://www.ebooklibonline.com>