

PUMA 140
PUMA 155
PUMA 170
PUMA 185
Tractor

SERVICE MANUAL

Part number 47770517

English

December 2015

© 2015 CNH industrial Latin America LTDA. All Rights Reserved.



Link Product / Engine

| Product | Market Product | Engine |
|-------------------------------------------------------------|-----------------------|----------------|
| PUMA® 140 Com cabine, 18x6, TIER 3 [HCCZ185CECW21177 -] | Asia Pacific | F4DE9684J*J106 |
| PUMA® 140 Com cabine, 18x6, TIER 3 [HCCZ185CECW21177 -] | Australia New Zealand | F4DE9684J*J106 |
| PUMA® 140 Com cabine, 18x6, TIER 3 [HCCZ185CECW21177 -] | Latin America | F4DE9684J*J106 |
| PUMA® 140 Com cabine, 18x6, TIER 3 [HCCZ185CECW21177 -] | Middle East Africa | F4DE9684J*J106 |
| PUMA® 155 Com cabine, 18x6, TIER 3 [HCCZ185CECW21177 -] | Asia Pacific | F4DE9684V*J101 |
| PUMA® 155 Com cabine, 18x6, TIER 3 [HCCZ185CECW21177 -] | Australia New Zealand | F4DE9684V*J101 |
| PUMA® 155 Com cabine, 18x6, TIER 3 [HCCZ185CECW21177 -] | Latin America | F4DE9684V*J101 |
| PUMA® 155 Com cabine, 18x6, TIER 3 [HCCZ185CECW21177 -] | Middle East Africa | F4DE9684V*J101 |
| PUMA® 170 Com cabine, 18x6, TIER 3 [HCCZ185CECW21177 -] | Asia Pacific | F4DE9687V*J105 |
| PUMA® 170 Com cabine, 18x6, TIER 3 [HCCZ185CECW21177 -] | Australia New Zealand | F4DE9687V*J105 |
| PUMA® 170 Com cabine, 18x6, TIER 3 [HCCZ185CECW21177 -] | Latin America | F4DE9687V*J105 |
| PUMA® 170 Com cabine, 18x6, TIER 3 [HCCZ185CECW21177 -] | Middle East Africa | F4DE9687V*J105 |
| PUMA® 185 Com cabine, 18x6, TIER 3 [HCCZ185CECW21177 -] | Middle East Africa | F4DE9684T*J102 |
| PUMA® 185 Com cabine, 18x6, TIER 3 [HCCZ185CECW21177 -] | Asia Pacific | F4DE9684T*J102 |
| PUMA® 185 Com cabine, 18x6, TIER 3 [HCCZ185CECW21177 -] | Latin America | F4DE9684T*J102 |
| PUMA® 185 Com cabine, 18x6, TIER 3 [HCCZ185CECW21177 -] | Australia New Zealand | F4DE9684T*J102 |

Contents

INTRODUCTION

| | |
|-----------------------------------------------------------------|-----------|
| Engine | 10 |
| [10.001] Engine and crankcase | 10.1 |
| [10.103] Crankshaft and flywheel..... | 10.2 |
| [10.216] Fuel tanks | 10.3 |
| [10.250] Turbocharger and lines..... | 10.4 |
| [10.254] Intake and exhaust manifolds and muffler | 10.5 |
| [10.400] Engine cooling system | 10.6 |
| Clutch | 18 |
| [18.110] Clutch and components | 18.1 |
| Transmission | 21 |
| [21.111] Semi-Powershift transmission | 21.1 |
| [21.133] Semi-Powershift transmission external controls | 21.2 |
| [21.152] Semi-Powershift transmission internal components | 21.3 |
| [21.160] Creeper | 21.4 |
| Four-Wheel Drive (4WD) system | 23 |
| [23.202] Electro-hydraulic control | 23.1 |
| Front axle system | 25 |
| [25.100] Powered front axle | 25.1 |
| [25.102] Front bevel gear set and differential | 25.2 |
| [25.108] Final drive hub, steering knuckles, and shafts | 25.3 |
| Rear axle system | 27 |
| [27.100] Powered rear axle..... | 27.1 |
| [27.106] Rear bevel gear set and differential | 27.2 |
| [27.120] Planetary and final drives | 27.3 |
| Power Take-Off (PTO) | 31 |

<https://www.ebooklibonline.com>

Hello dear friend!

Thank you very much for reading.

Enter the link into your browser.

The full manual is available for immediate download.

<https://www.ebooklibonline.com>

| | |
|--------------------------------------------------------|-----------|
| [31.104] Rear electro-hydraulic control | 31.1 |
| [31.114] Two-speed rear Power Take-Off (PTO) | 31.2 |
| Brakes and controls | 33 |
| [33.202] Hydraulic service brakes | 33.1 |
| [33.300] Pneumatic service brakes | 33.2 |
| [33.110] Parking brake or parking lock | 33.3 |
| Hydraulic systems..... | 35 |
| [35.000] Hydraulic systems..... | 35.1 |
| [35.106] Variable displacement pump | 35.2 |
| [35.102] Pump control valves..... | 35.3 |
| [35.105] Charge pump..... | 35.4 |
| [35.204] Remote control valves | 35.5 |
| [35.114] Three-point hitch control valve | 35.6 |
| [35.116] Three-point hitch cylinder | 35.7 |
| Pneumatic system | 36 |
| [36.100] Pneumatic system..... | 36.1 |
| Hitches, drawbars, and implement couplings..... | 37 |
| [37.100] Drawbars and towing hitches | 37.1 |
| [37.110] Rear three-point hitch | 37.2 |
| Frames and ballasting | 39 |
| [39.100] Frame | 39.1 |
| [39.140] Ballasts and supports | 39.2 |
| Steering..... | 41 |
| [41.101] Steering control | 41.1 |
| [41.106] Tie rods..... | 41.2 |
| [41.200] Hydraulic control components..... | 41.3 |
| [41.206] Pump | 41.4 |

| | |
|-----------------------------------------------------------------|-----------|
| [41.216] Cylinders | 41.5 |
| Wheels | 44 |
| [44.511] Front wheels | 44.1 |
| [44.520] Rear wheels | 44.2 |
| Cab climate control | 50 |
| [50.100] Heating | 50.1 |
| [50.104] Ventilation | 50.2 |
| [50.200] Air conditioning | 50.3 |
| Electrical systems | 55 |
| [55.100] Harnesses and connectors | 55.1 |
| [55.302] Battery | 55.2 |
| [55.640] Electronic modules | 55.3 |
| [55.045] Front axle control system | 55.4 |
| [55.130] Rear three-point hitch electronic control system | 55.5 |
| [55.DTC] FAULT CODES | 55.6 |
| Platform, cab, bodywork, and decals | 90 |
| [90.150] Cab | 90.1 |
| [90.151] Cab interior | 90.2 |
| [90.100] Engine hood and panels | 90.3 |
| [90.102] Engine shields, hood latches, and trims | 90.4 |



INTRODUCTION

Safety rules - Ecology and the environment

Soil, air, and water quality is important for all industries and life in general. When legislation does not yet rule the treatment of some of the substances that advanced technology requires, sound judgment should govern the use and disposal of products of a chemical and petrochemical nature.

Familiarize yourself with the relative legislation applicable to your country, and make sure that you understand this legislation. Where no legislation exists, obtain information from suppliers of oils, filters, batteries, fuels, anti-freeze, cleaning agents, etc., with regard to the effect of these substances on man and nature and how to safely store, use, and dispose of these substances.

Helpful hints

- Avoid the use of cans or other inappropriate pressurized fuel delivery systems to fill tanks. Such delivery systems may cause considerable spillage.
- In general, avoid skin contact with all fuels, oils, acids, solvents, etc. Most of these products contain substances that may be harmful to your health.
- Modern oils contain additives. Do not burn contaminated fuels and or waste oils in ordinary heating systems.
- Avoid spillage when you drain fluids such as used engine coolant mixtures, engine oil, hydraulic fluid, brake fluid, etc. Do not mix drained brake fluids or fuels with lubricants. Store all drained fluids safely until you can dispose of the fluids in a proper way that complies with all local legislation and available resources.
- Do not allow coolant mixtures to get into the soil. Collect and dispose of coolant mixtures properly.
- The air-conditioning system contains gases that should not be released into the atmosphere. Consult an air-conditioning specialist or use a special extractor to recharge the system properly.
- Repair any leaks or defects in the engine cooling system or hydraulic system immediately.
- Do not increase the pressure in a pressurized circuit as this may lead to a component failure.
- Protect hoses during welding. Penetrating weld splatter may burn a hole or weaken hoses, allowing the loss of oils, coolant, etc.

Battery recycling

Batteries and electric accumulators contain several substances that can have a harmful effect on the environment if the batteries are not properly recycled after use. Improper disposal of batteries can contaminate the soil, groundwater, and waterways. CASE IH strongly recommends that you return all used batteries to a CASE IH dealer, who will dispose of the used batteries or recycle the used batteries properly. In some countries, this is a legal requirement.



Mandatory battery recycling

NOTE: The following requirements are mandatory in Brazil.

Batteries are made of lead plates and a sulfuric acid solution. Because batteries contain heavy metals such as lead, CONAMA Resolution 401/2008 requires you to return all used batteries to the battery dealer when you replace any batteries. Do not dispose of batteries in your household garbage.

Points of sale are obliged to:

- Accept the return of your used batteries
- Store the returned batteries in a suitable location
- Send the returned batteries to the battery manufacturer for recycling

Safety rules

Personal safety





This is the safety alert symbol. It is used to alert you to potential personal injury hazards. Obey all safety messages that follow this symbol to avoid possible death or injury.

Throughout this manual and on machine safety signs, you will find the signal words DANGER, WARNING, and CAUTION followed by special instructions. These precautions are intended for the personal safety of you and those working with you.

Read and understand all the safety messages in this manual before you operate or service the machine.

 DANGER indicates a hazardous situation that, if not avoided, will result in death or serious injury. The color associated with DANGER is RED.

 WARNING indicates a hazardous situation that, if not avoided, could result in death or serious injury. The color associated with WARNING is ORANGE.

 CAUTION indicates a hazardous situation that, if not avoided, could result in minor or moderate injury. The color associated with CAUTION is YELLOW.

FAILURE TO FOLLOW DANGER, WARNING, AND CAUTION MESSAGES COULD RESULT IN DEATH OR SERIOUS INJURY.

Machine safety

NOTICE: Notice indicates a situation that, if not avoided, could result in machine damage or property damage. The color associated with Notice is BLUE.

Throughout this manual you will find the signal word Notice followed by special instructions to prevent machine damage or property damage. The word Notice is used to address practices not related to personal safety.

Information

NOTE: Note indicates additional information that clarifies steps, procedures, or other information in this manual.

Throughout this manual you will find the word Note followed by additional information about a step, procedure, or other information in the manual. The word Note is not intended to address personal safety or property damage.

Basic instructions — Shop and assembly

| | |
|--------------------------------------------------------|----|
| PUMA® 140 With cab, 18X6, TIER 3 [HCCZ185CECW21177 -] | LA |
| PUMA® 155 With cab, 18X6, TIER 3 [HCCZ185CECW21177 -] | LA |
| PUMA® 170 With cab, 18X6, TIER 3 [HCCZ185CECW21177 -] | LA |
| PUMA® 185 With cab, 18X6, TIER 3 [HCCZ185CECW21177 -] | LA |

Shimming

For each adjustment operation, select adjusting shims and measure the adjusting shims individually using a micrometer, then add up the recorded values. Do not rely on measuring the entire shimming set, which may be incorrect, or the rated value shown on each shim.

Rotating shaft seals

For correct rotating shaft seal installation, proceed as follows:

1. Before assembly, allow the seal to soak in the oil it will be sealing for at least thirty minutes.
2. Thoroughly clean the shaft and check that the working surface on the shaft is not damaged.
3. Position the sealing lip facing the fluid.

NOTE: *With hydrodynamic lips, take into consideration the shaft rotation direction and position the grooves so that they will move the fluid towards the inner side of the seal.*

4. Coat the sealing lip with a thin layer of lubricant (use oil rather than grease). Fill the gap between the sealing lip and the dust lip on double lip seals with grease.
5. Insert the seal in its seat and press down using a flat punch or seal installation tool. Do not tap the seal with a hammer or mallet.
6. While you insert the seal, check that the seal is perpendicular to the seat. When the seal settles, make sure that the seal makes contact with the thrust element, if required.
7. To prevent damage to the seal lip on the shaft, position a protective guard during installation operations.

O-ring seals

Lubricate the O-ring seals before you insert them in the seats. This will prevent the O-ring seals from overturning and twisting, which would jeopardize sealing efficiency.

Sealing compounds

Apply a sealing compound on the mating surfaces when specified by the procedure. Before you apply the sealing compound, prepare the surfaces as directed by the product container.

Spare parts

Only use CNH Original Parts or CASE IH Original Parts.

Only genuine spare parts guarantee the same quality, duration, and safety as original parts, as they are the same parts that are assembled during standard production. Only CNH Original Parts or CASE IH Original Parts can offer this guarantee.

When ordering spare parts, always provide the following information:

- Machine model (commercial name) and Product Identification Number (PIN)
- Part number of the ordered part, which can be found in the parts catalog

Protecting the electronic and/or electrical systems during charging and welding

To avoid damage to the electronic and/or electrical systems, always observe the following practices:

1. Never make or break any of the charging circuit connections when the engine is running, including the battery connections.
2. Never short any of the charging components to ground.
3. Always disconnect the ground cable from the battery before arc welding on the machine or on any machine attachment.
 - Position the welder ground clamp as close to the welding area as possible.
 - If you weld in close proximity to a computer module, then you should remove the module from the machine.
 - Never allow welding cables to lie on, near, or across any electrical wiring or electronic component while you weld.
4. Always disconnect the negative cable from the battery when charging the battery in the machine with a battery charger.

NOTICE: *If you must weld on the unit, you must disconnect the battery ground cable from the machine battery. The electronic monitoring system and charging system will be damaged if this is not done.*

5. Remove the battery ground cable. Reconnect the cable when you complete welding.

WARNING

Battery acid causes burns. Batteries contain sulfuric acid.

Avoid contact with skin, eyes or clothing. Antidote (external): Flush with water. Antidote (eyes): flush with water for 15 minutes and seek medical attention immediately. Antidote (internal): Drink large quantities of water or milk. Do not induce vomiting. Seek medical attention immediately. Failure to comply could result in death or serious injury.

W0111A

Special tools

The special tools that CASE IH suggests and illustrate in this manual have been specifically researched and designed for use with CASE IH machines. The special tools are essential for reliable repair operations. The special tools are accurately built and rigorously tested to offer efficient and long-lasting operation.

By using these tools, repair personnel will benefit from:

- Operating in optimal technical conditions
- Obtaining the best results
- Saving time and effort
- Working in safe conditions



SERVICE MANUAL

Engine

PUMA® 140 With cab, 18X6, TIER 3 [HCCZ185CECW21177 -]
PUMA® 155 With cab, 18X6, TIER 3 [HCCZ185CECW21177 -]
PUMA® 170 With cab, 18X6, TIER 3 [HCCZ185CECW21177 -]
PUMA® 185 With cab, 18X6, TIER 3 [HCCZ185CECW21177 -]

Engine - Connect

| | |
|--------------------------------------------------------|----|
| PUMA® 140 With cab, 18X6, TIER 3 [HCCZ185CECW21177 -] | LA |
| PUMA® 155 With cab, 18X6, TIER 3 [HCCZ185CECW21177 -] | LA |
| PUMA® 170 With cab, 18X6, TIER 3 [HCCZ185CECW21177 -] | LA |
| PUMA® 185 With cab, 18X6, TIER 3 [HCCZ185CECW21177 -] | LA |

⚠ CAUTION

Heavy object!

The component is heavy. Use care not to drop the component when installing, removing, or handling. Failure to comply could result in minor or moderate injury.

C0095A

1. Line up the front support and engine assembly with the transmission. Install the engine on the transmission fixing bolts. Torque to **285 - 315 N·m (2522 - 2788 lb in)**. Remove the separation kit from the tractor.

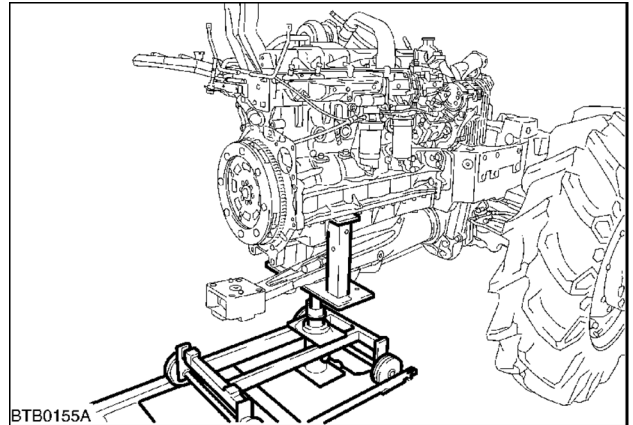

BTB0155A

BTB0155A 1

2. Install the flywheel speed sensor.

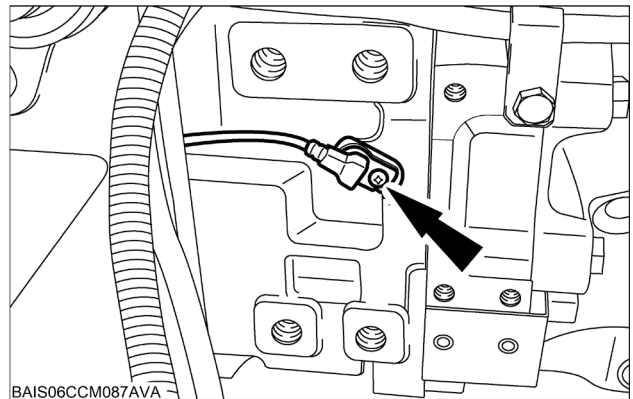

BAIS06CCM087AVA

BAIS06CCM087AVA 2

3. Install the spacer (2) and install the fixing bolts (1).

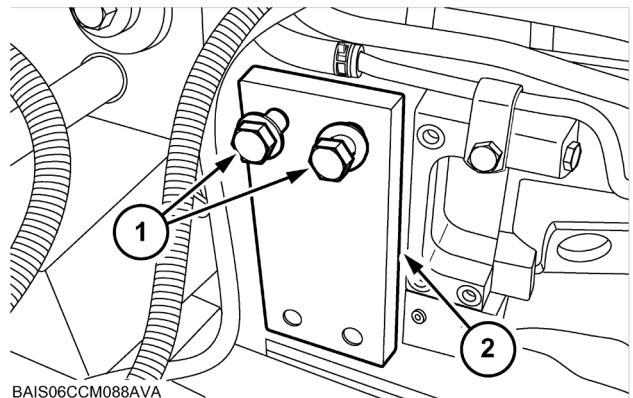

BAIS06CCM088AVA

BAIS06CCM088AVA 3

4. Connect the supply hose of the hydraulic brake master cylinder.

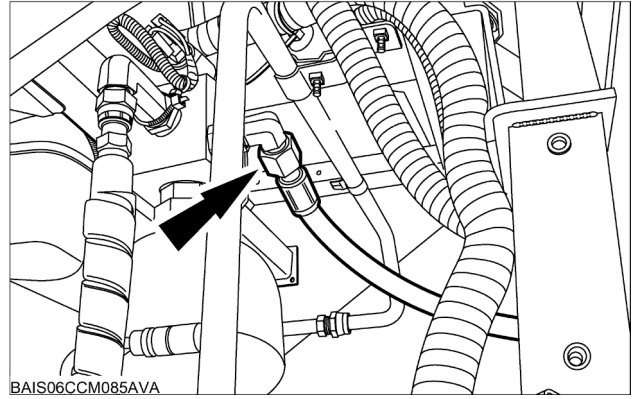

BAIS06CCM085AVA 4

5. Connect the transmission oil cooler pipes (1) and (2).

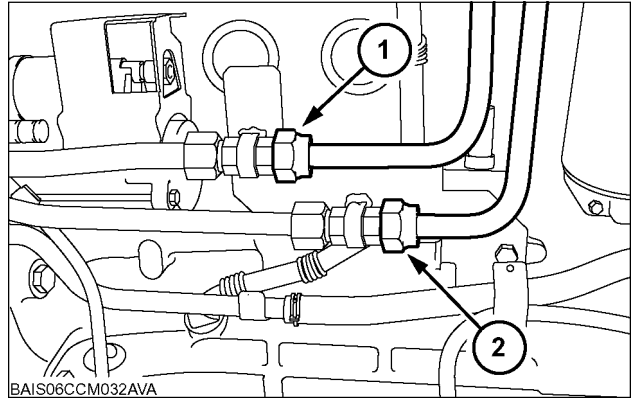

BAIS06CCM032AVA 5

6. Install the transmission shaft flange, if installed.
Tighten the M24 nut (if installed) to **294 N·m (217 lb ft)**.
Tighten the M12 bolt (if installed) to **80 N·m (59 lb ft)**.

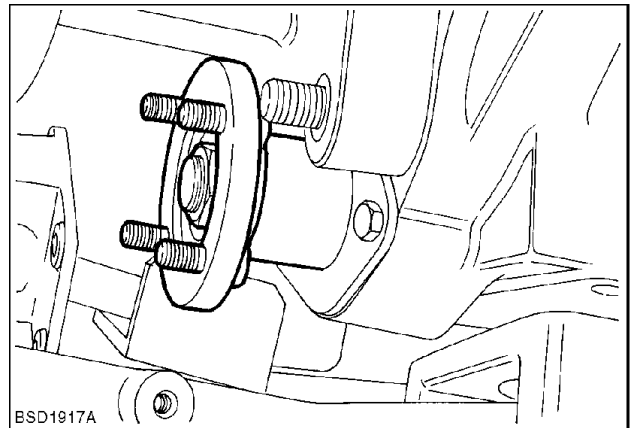

BSD1917A 6

7. Install the drive shaft and then the metal guard.

8. Connect the differential lock supply hose (1).

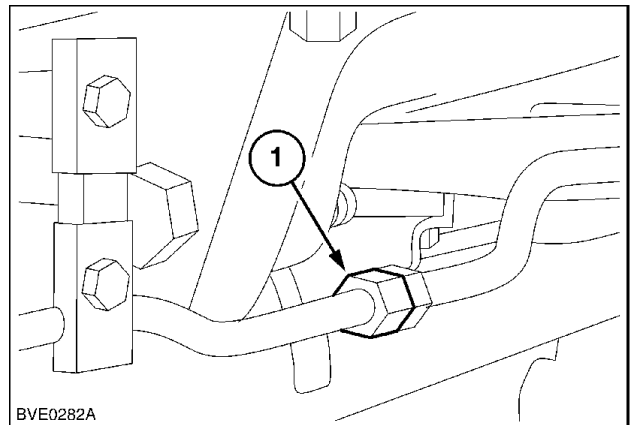

BVE0282A 7

9. Connect the supply hose of the hydraulic brake valve.

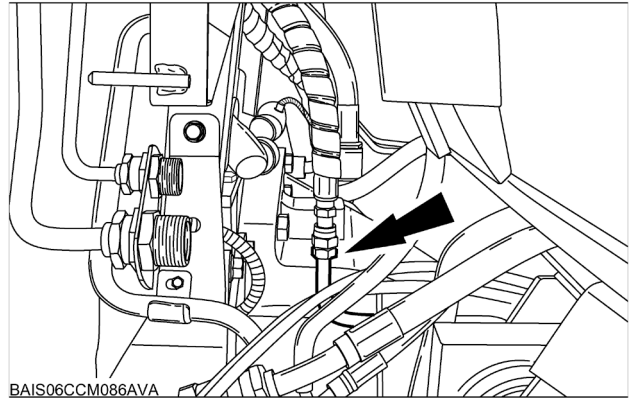

BAIS06CCM086AVA

BAIS06CCM086AVA 8

10. Connect the fuel supply and return lines.

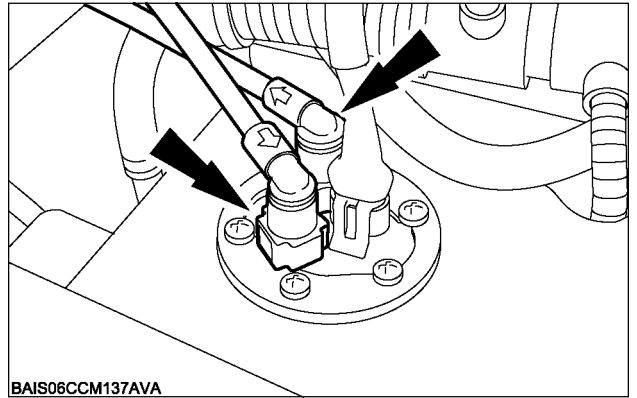

BAIS06CCM137AVA

BAIS06CCM137AVA 9

11. Connect the oil supply hoses of the steering cylinder (1) and (2).

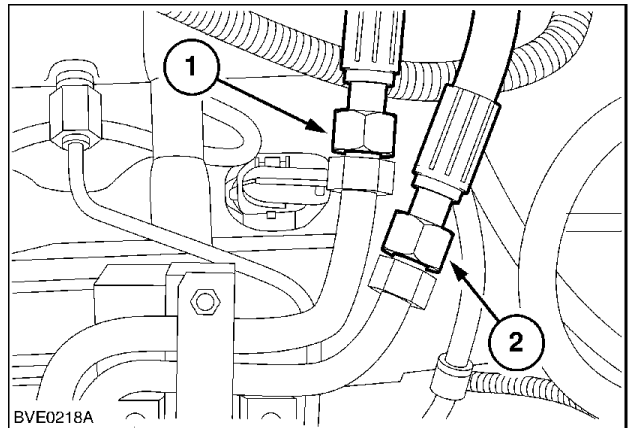

EVE0218A

EVE0218A 10

12. Connect the high-pressure hose (1) and the low-pressure hose (2) of the air conditioning.

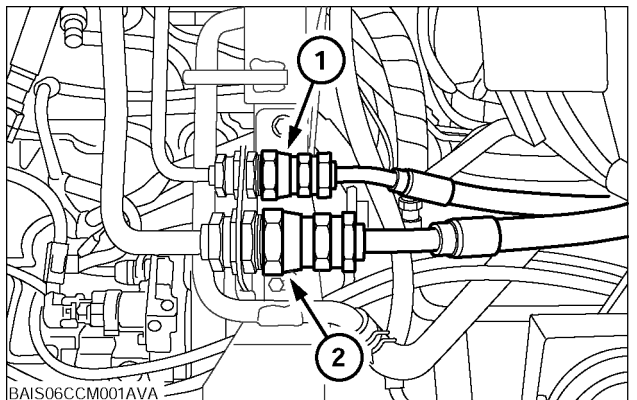

BAIS06CCM001AVA

BAIS06CCM001AVA 11

13. Connect the cab heater hose.

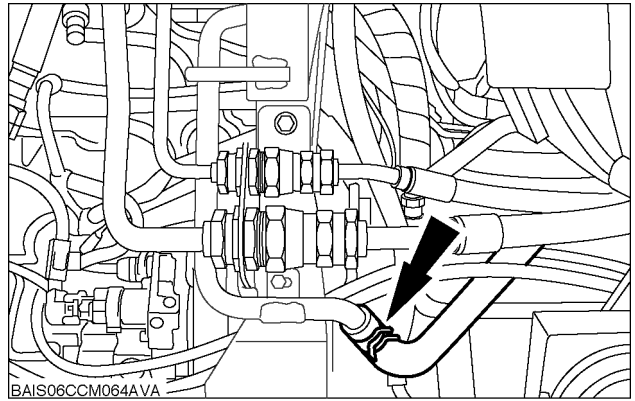

BAIS06CCM064AVA 12

14. Connect the cab heater hose to the radiator.

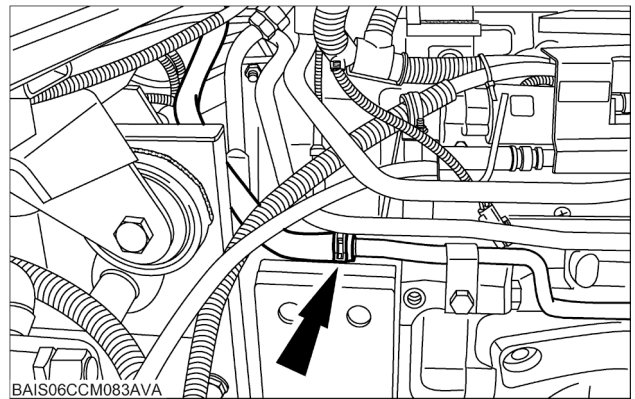

BAIS06CCM083AVA 13

15. Connect the positive battery cable (2) and the negative cable (ground) (1).
16. Connect the engine wire harness connectors.

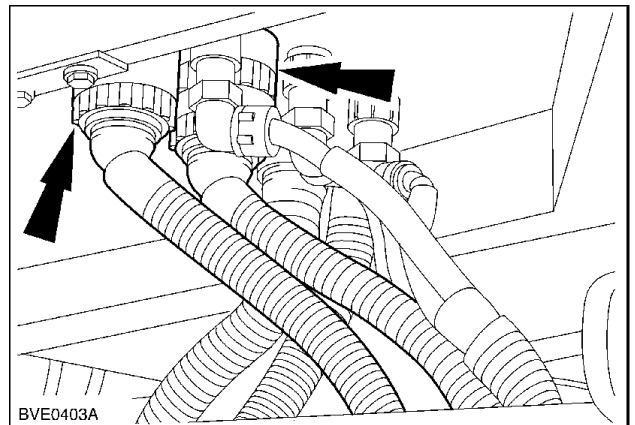

BVE0403A 14

17. Install the exhaust muffler. See **Exhaust muffler - Install (10.254)**.

18. When installed, install the radar (2). Connect the radar electrical connector (1).

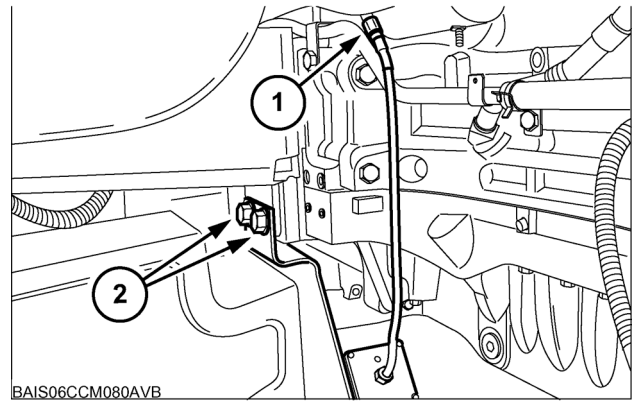

BAIS06CCM080AVB 15

19. Install the side shield on both sides of the engine.
20. Connect the battery ground lead.
21. Fill the engine cooling system. For more information, see **Engine cooling system - Change fluid (10.400)**.

Next operation:
Front ballast - Install (39.140)

Engine - Remove

| | |
|--------------------------------------------------------|----|
| PUMA® 140 With cab, 18X6, TIER 3 [HCCZ185CECW21177 -] | LA |
| PUMA® 155 With cab, 18X6, TIER 3 [HCCZ185CECW21177 -] | LA |
| PUMA® 170 With cab, 18X6, TIER 3 [HCCZ185CECW21177 -] | LA |
| PUMA® 185 With cab, 18X6, TIER 3 [HCCZ185CECW21177 -] | LA |

⚠ DANGER

Heavy objects!

Lift and handle all heavy components using lifting equipment with adequate capacity. Always support units or parts with suitable slings or hooks. Make sure the work area is clear of all bystanders. Failure to comply will result in death or serious injury.

D0076A

⚠ DANGER

Pressurized system!

Always remove all pressure before working on the hydraulic system. Follow the pressure BLEED program in the Configuration Mode to remove the pressure in the entire hydraulic system. Failure to comply will result in death or serious injury.

D0035A

Prior operation:

Front frame - Remove (39.100)

1. Disconnect the lighting wiring electrical connector.

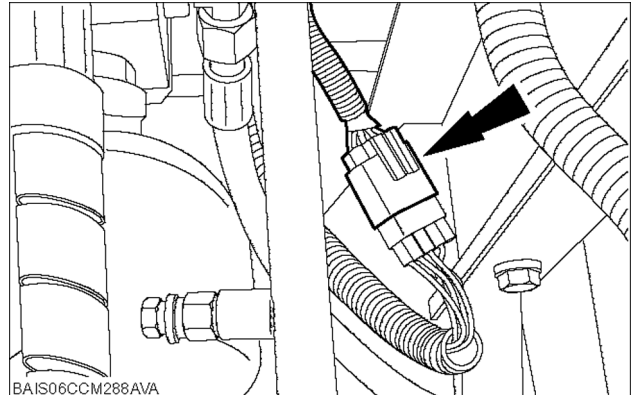

BAIS06CCM288AVA 1

2. Remove the hood.
3. Remove the exhaust muffler. See **Exhaust muffler - Remove (10.254)**.
4. Disconnect the radar electrical connector (1).
Remove the radar (2).

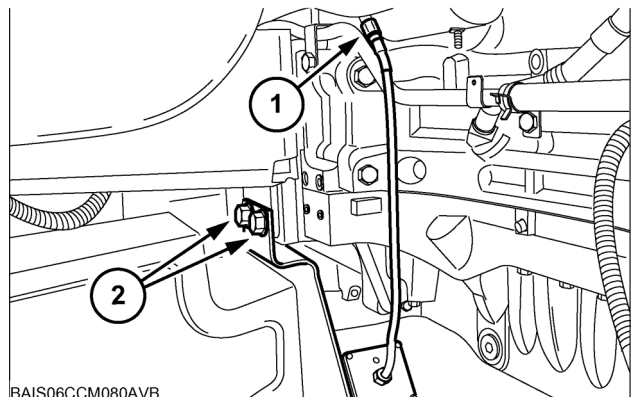

BAIS06CCM080AVB 2

5. Disconnect the cab heater coolant hose.

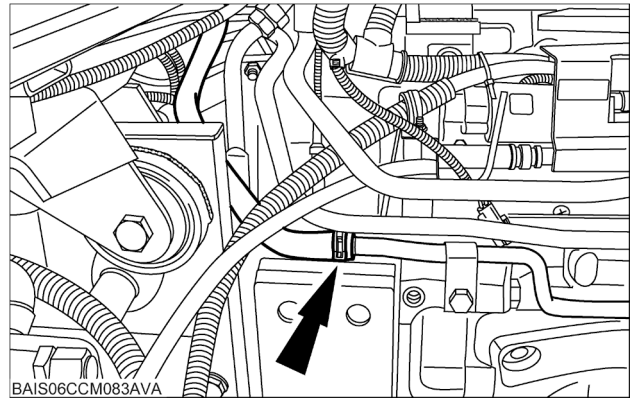

BAIS06CCM083AVA

BAIS06CCM083AVA 3

6. Remove the electrical wiring from the air filter frame (1).
Remove the filter-drier from the air filter frame (2).

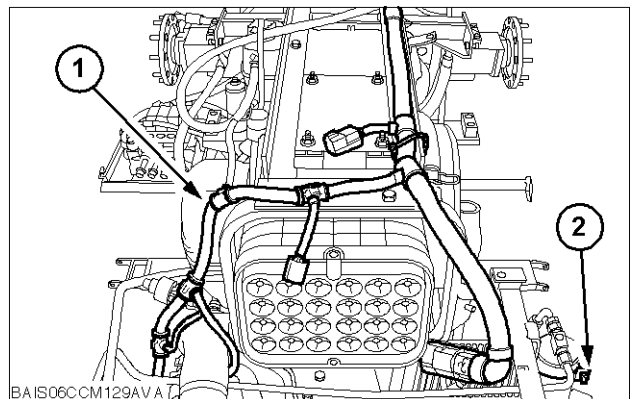

BAIS06CCM129AVA

BAIS06CCM129AVA 4

7. Disconnect the high-pressure hose (1) and the low-pressure hose (2) of the air conditioning.
Remove the high pressure hose fixing bolt (3) and clamp (4).

NOTE: You do not need to drain the air conditioning system because the joints are self-sealing.

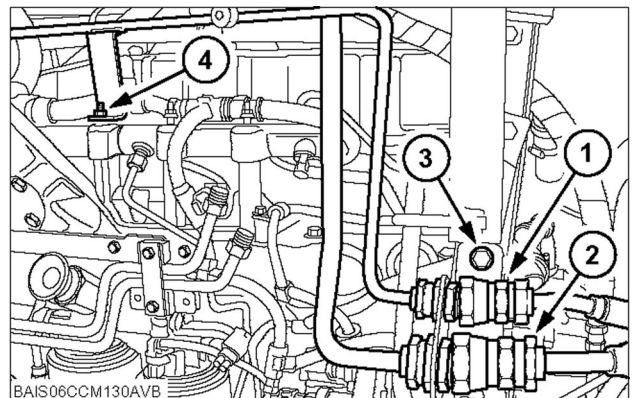

BAIS06CCM130AVB

BAIS06CCM130AVB 5

8. Disconnect the hydraulic brake hose.

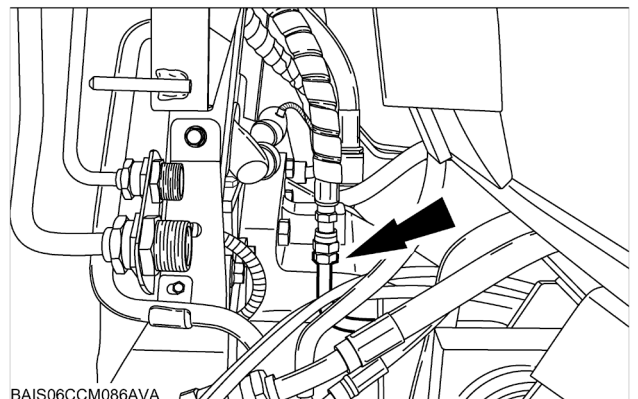

BAIS06CCM086AVA

BAIS06CCM086AVA 6

9. Disconnect the differential lock supply hose (1) and remove the support (2).

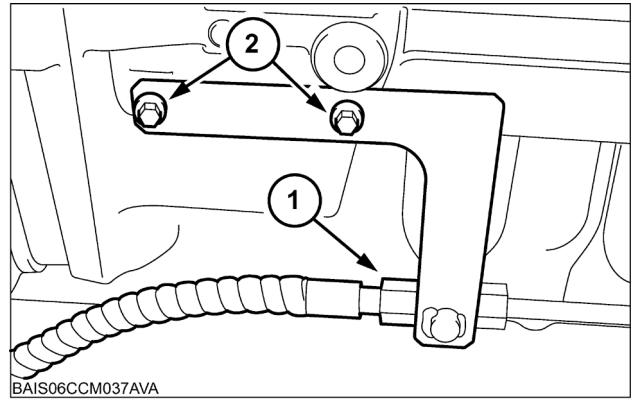

BAIS06CCM037AVA

BAIS06CCM037AVA 7

10. Disconnect the steering cylinder supply hoses (1) and (2).

NOTE: Note the position of the steering cylinder oil feed hoses.

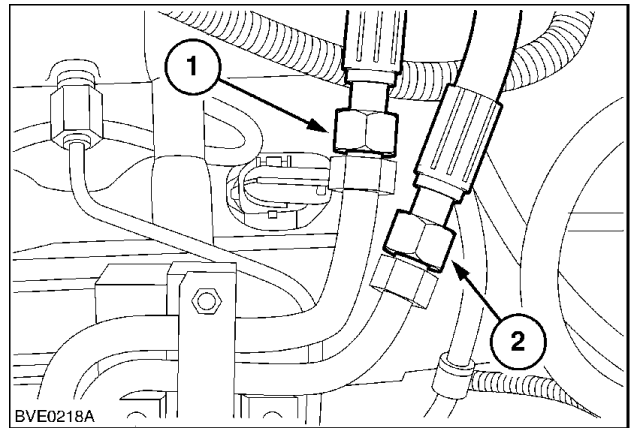

BVE0218A

BVE0218A 8

11. Disconnect the hydraulic brake ventilation hose.

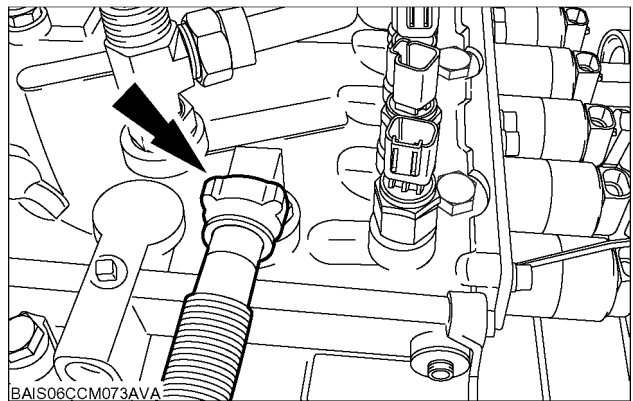

BAIS06CCM073AVA

BAIS06CCM073AVA 9

12. Disconnect the engine wiring electrical connectors.

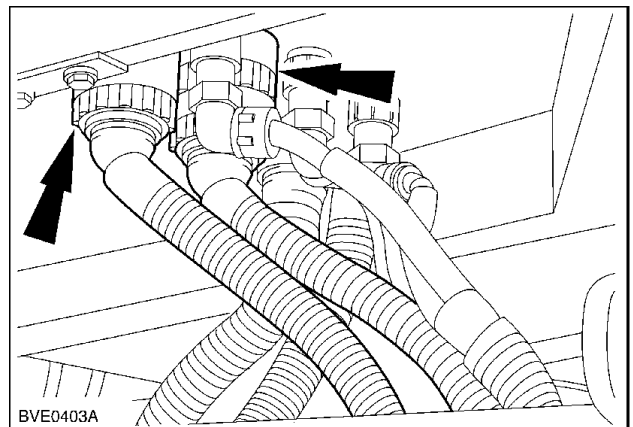

BVE0403A

BVE0403A_37 10

13. Disconnect the fuel supply and return lines.

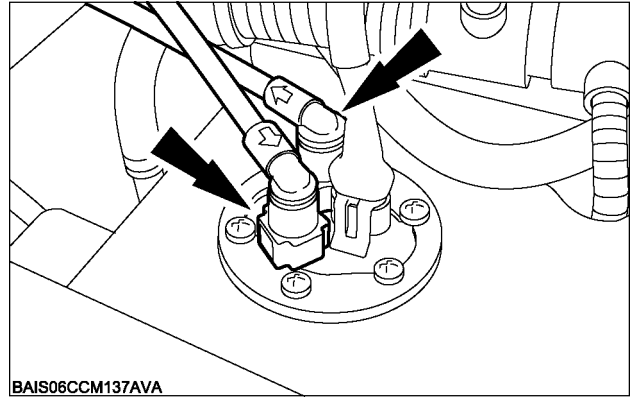

BAIS06CCM137AVA 11

14. Remove the attachment drive chain.

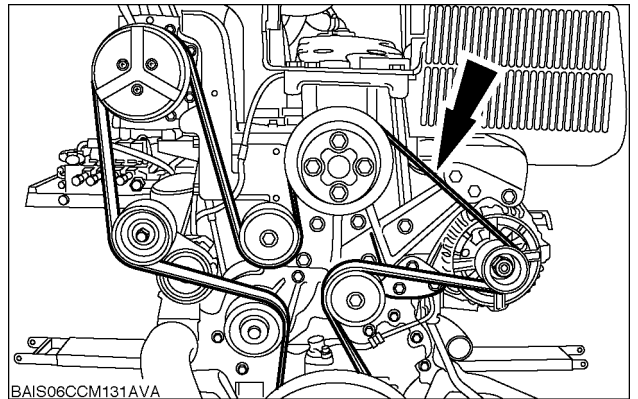

BAIS06CCM131AVA 12

15. Remove the air-conditioning compressor assembly, the condenser filter-drier, and the tubing from the engine. Do not disconnect the tubing. See **Air-conditioning compressor - Remove (50.200)**.

16. Disconnect the expansion tube (1) and the engine breather tube (2).

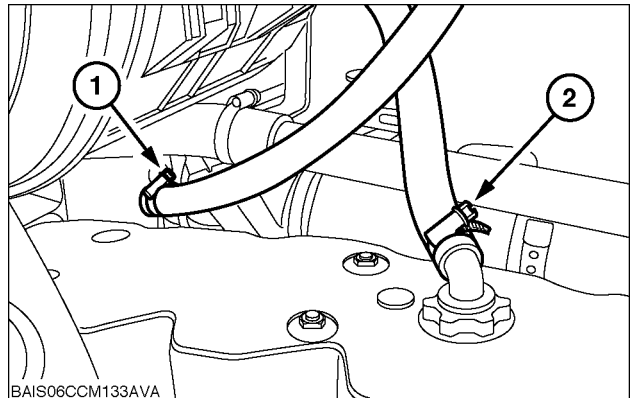

BAIS06CCM133AVA 13

17. Disconnect the turbo air filter outlet hose.

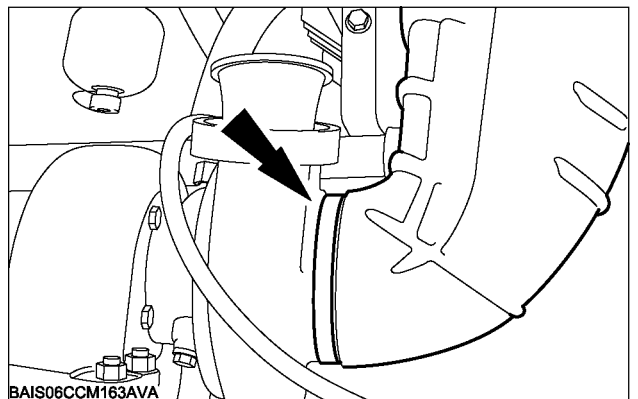

BAIS06CCM163AVA 14



Suggest:

If the above button click is invalid.

Please download this document

first, and then click the above link

to download the complete manual.

Thank you so much for reading

18. Remove the front fixing bolts of the air filter mounting frame.

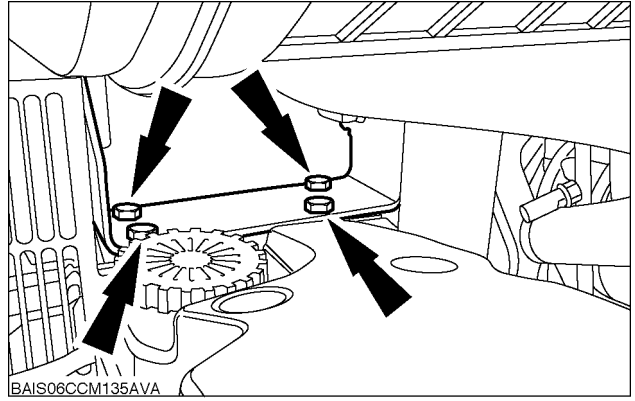

BAIS06CCM135AVA 15

19. Remove the engine wiring clamp fixing bolts and reposition the engine wiring on top of the engine.

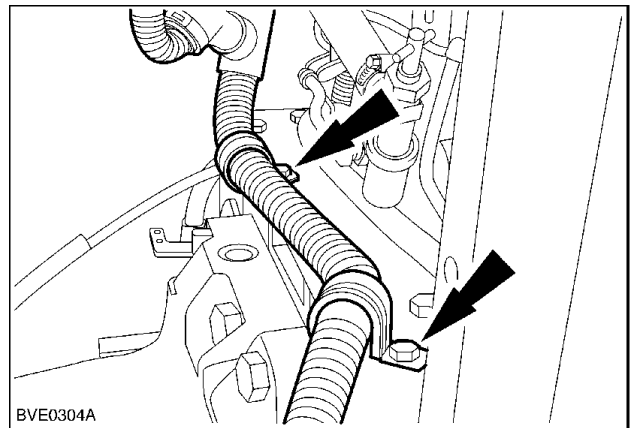

BVE0304A 16

20. Remove the rear fixing bolts of the air filter mounting frame.

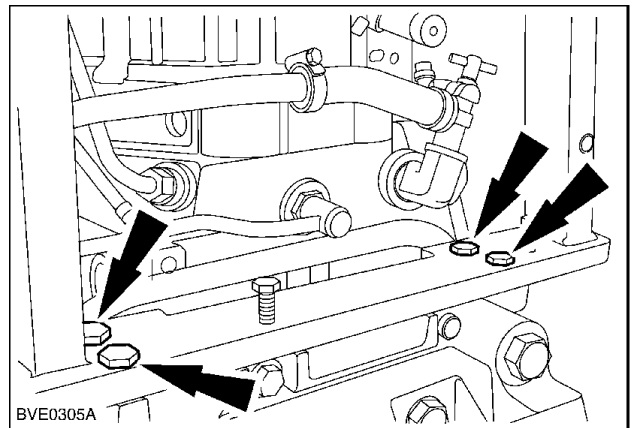

BVE0305A 17

21. Remove the air filter mounting frame with a suitable chain and a hoist.

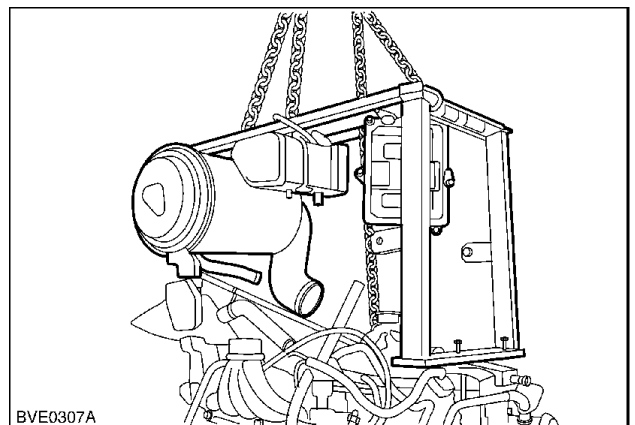

BVE0307A 18

<https://www.ebooklibonline.com>

Hello dear friend!

Thank you very much for reading.

Enter the link into your browser.

The full manual is available for immediate download.

<https://www.ebooklibonline.com>