

MAXXUM 110 EP
MAXXUM 115 EP
MAXXUM 120 EP
MAXXUM 125 EP
MAXXUM 130 EP
MAXXUM 140 EP
MAXXUM 110 Multicontroller EP
MAXXUM 115 Multicontroller EP
MAXXUM 120 Multicontroller EP
MAXXUM 125 Multicontroller EP
MAXXUM 130 Multicontroller EP
MAXXUM 140 Multicontroller EP
MAXXUM CVX 110
MAXXUM CVX 120
MAXXUM CVX 130
Tractor

SERVICE MANUAL

Part number 47665845

English

February 2014

Copyright © 2014 CNH Industrial Österreich GmbH. All Rights Reserved.

CASE II
AGRICULTURE

SERVICE MANUAL



**MAXXUM 110 EP , MAXXUM 110 Multicontroller EP , MAXXUM 115 EP
 , MAXXUM 115 Multicontroller EP , MAXXUM 120 EP , MAXXUM 120
 Multicontroller EP , MAXXUM 125 EP , MAXXUM 125 Multicontroller EP ,
 MAXXUM 130 EP , MAXXUM 130 Multicontroller EP , MAXXUM 140 EP ,
 MAXXUM 140 Multicontroller EP , MAXXUM CVX 110 , MAXXUM CVX 120
 , MAXXUM CVX 130**

Link Product / Engine

Product	Market Product	Engine
MAXXUM CVX 110	Europe	F4DFE413C*A
MAXXUM CVX 120	Europe	F4DFE413B*A
MAXXUM CVX 130	Europe	F4DFE413A*A
MAXXUM 110 EP	Europe	F4DFE413E*A
MAXXUM 110 Multicontroller EP	Europe	F4DFE413C*A
MAXXUM 115 EP	Europe	F4DFE613F*A
MAXXUM 115 Multicontroller EP	Europe	F4DFE613F*A
MAXXUM 120 EP	Europe	F4DFE413D*A
MAXXUM 120 Multicontroller EP	Europe	F4DFE413B*A
MAXXUM 125 EP	Europe	F4DFE613E*A
MAXXUM 125 Multicontroller EP	Europe	F4DFE613E*A
MAXXUM 130 EP	Europe	F4DFE413C*A
MAXXUM 130 Multicontroller EP	Europe	F4DFE413A*A
MAXXUM 140 EP	Europe	F4DFE6132*A
MAXXUM 140 Multicontroller EP	Europe	F4DFE6132*A

<https://www.ebooklibonline.com>

Hello dear friend!

Thank you very much for reading.

Enter the link into your browser.

The full manual is available for immediate download.

<https://www.ebooklibonline.com>

Contents

INTRODUCTION

Engine	10
[10.001] Engine and crankcase	10.1
[10.216] Fuel tanks	10.2
[10.218] Fuel injection system.....	10.3
[10.202] Air cleaners and lines	10.4
[10.250] Turbocharger and lines.....	10.5
[10.254] Intake and exhaust manifolds and muffler	10.6
[10.500] Selective Catalytic Reduction (SCR) exhaust treatment.....	10.7
[10.400] Engine cooling system	10.8
[10.414] Fan and drive	10.9
[10.310] Aftercooler.....	10.10
Clutch	18
[18.112] Slip clutch or flywheel damper	18.1
Transmission	21
[21.112] Power shuttle transmission.....	21.1
[21.134] Power shuttle transmission external controls	21.2
[21.154] Power shuttle transmission internal components	21.3
[21.111] Semi-Powershift transmission	21.4
[21.133] Semi-Powershift transmission external controls	21.5
[21.103] Semi-Powershift transmission lubrication system.....	21.6
[21.152] Semi-Powershift transmission internal components	21.7
[21.504] Continuously Variable Transmission (CVT)	21.8
[21.505] Continuously Variable Transmission (CVT) external controls.....	21.9
[21.506] Continuously Variable Transmission (CVT) lubrication system	21.10
[21.507] Continuously Variable Transmission (CVT) internal components	21.11
[21.160] Creeper	21.12

[21.166] Overdrive	21.13
Four-Wheel Drive (4WD) system	23
[23.202] Electro-hydraulic control	23.1
[23.314] Drive shaft	23.2
Front axle system	25
[25.100] Powered front axle	25.1
[25.102] Front bevel gear set and differential	25.2
[25.108] Final drive hub, steering knuckles, and shafts	25.3
[25.122] Axle suspension control	25.4
Rear axle system	27
[27.100] Powered rear axle	27.1
[27.106] Rear bevel gear set and differential	27.2
[27.120] Planetary and final drives	27.3
Power Take-Off (PTO)	31
[31.104] Rear electro-hydraulic control	31.1
[31.114] Two-speed rear Power Take-Off (PTO)	31.2
[31.116] Three-speed rear Power Take-Off (PTO)	31.3
[31.142] Front Power Take-Off (PTO) control	31.4
[31.146] Front Power Take-Off (PTO)	31.5
Brakes and controls	33
[33.202] Hydraulic service brakes	33.1
[33.110] Parking brake or parking lock	33.2
[33.204] Front axle brake	33.3
[33.220] Trailer brake hydraulic control	33.4
[33.224] Trailer brake pneumatic control	33.5
Hydraulic systems	35
[35.000] Hydraulic systems	35.1

[35.300] Reservoir, cooler, and filters.....	35.2
[35.104] Fixed displacement pump.....	35.3
[35.106] Variable displacement pump	35.4
[35.105] Charge pump.....	35.5
[35.322] Regulated/Low pressure system.....	35.6
[35.204] Remote control valves	35.7
[35.220] Auxiliary hydraulic pump and lines	35.8
[35.114] Three-point hitch control valve	35.9
[35.116] Three-point hitch cylinder	35.10
[35.160] Front hitch controls and lines	35.11
Hitches, drawbars, and implement couplings.....	37
[37.120] Rear three-point hitch linkage.....	37.1
Frames and ballasting	39
[39.100] Frame	39.1
Steering.....	41
[41.101] Steering control	41.1
[41.106] Tie rods.....	41.2
[41.200] Hydraulic control components.....	41.3
[41.206] Pump	41.4
[41.216] Cylinders	41.5
Wheels.....	44
[44.511] Front wheels.....	44.1
[44.520] Rear wheels.....	44.2
Cab climate control	50
[50.100] Heating	50.1
[50.104] Ventilation	50.2
[50.200] Air conditioning.....	50.3
Electrical systems.....	55

- [55.000] Electrical system 55.1
- [55.100] Harnesses and connectors..... 55.2
- [55.015] Engine control system..... 55.3
- [55.301] Alternator..... 55.4
- [55.302] Battery..... 55.5
- [55.011] Fuel tank system 55.6
- [55.988] Selective Catalytic Reduction (SCR) electrical system 55.7
- [55.012] Engine cooling system 55.8
- [55.640] Electronic modules 55.9
- [55.513] Cab transmission controls..... 55.10
- [55.024] Transmission control system..... 55.11
- [55.020] Transmission speed sensors..... 55.12
- [55.021] Transmission pressure sensors 55.13
- [55.022] Transmission temperature sensors 55.14
- [55.023] Transmission position sensors 55.15
- [55.610] Ground speed control 55.16
- [55.048] Rear Power Take-Off (PTO) control system 55.17
- [55.031] Parking brake electrical system 55.18
- [55.035] Remote control valve electric control 55.19
- [55.051] Cab Heating, Ventilation, and Air-Conditioning (HVAC) controls..... 55.20
- [55.050] Heating, Ventilation, and Air-Conditioning (HVAC) control system..... 55.21
- [55.047] Steering control system 55.22
- [55.130] Rear three-point hitch electronic control system 55.23
- [55.911] Global Positioning System (GPS) 55.24
- [55.405] External lighting switches and relays 55.25
- [55.510] Cab or platform harnesses and connectors..... 55.26
- [55.408] Warning indicators, alarms, and instruments 55.27
- [55.DTC] FAULT CODES..... 55.28

Platform, cab, bodywork, and decals	90
[90.150] Cab	90.1
[90.100] Engine hood and panels	90.2



INTRODUCTION

Foreword

IMPORTANT INFORMATION

All repair and maintenance works listed in this manual must be carried out only by staff belonging to the CASE IH Service network, strictly complying with the instructions given and using, whenever required, the special tools.

Anyone who carries out the above operations without complying with the prescriptions shall be responsible for the subsequent damages.

The manufacturer and all the organizations of its distribution chain, including - without limitation - national, regional or local dealers, reject any responsibility for damages due to the anomalous behavior of parts and/or components not approved by the manufacturer himself, including those used for the servicing or repair of the product manufactured or marketed by the Manufacturer. In any case, no warranty is given or attributed on the product manufactured or marketed by the Manufacturer in case of damages due to an anomalous behavior of parts and/or components not approved by the Manufacturer.

No reproduction, though partial of text and illustrations allowed.

Foreword - How to use and navigate through this manual

This manual has been produced by a new technical information system. This new system is designed to deliver technical information electronically through web delivery (eTIM), DVD, and paper manuals. A coding system called SAP has been developed to link the technical information to other Product Support functions, e.g., Warranty.

Technical information is written to support the maintenance and service of the functions or systems on a customer's machine. When a customer has a concern on their machine it is usually because a function or system on their machine is not working at all, is not working efficiently, or is not responding correctly to their commands. When you refer to the technical information in this manual to resolve that customer's concern, you will find all the information classified using the SAP coding, according to the functions or systems on that machine. Once you have located the technical information for that function or system, you will then find all the mechanical, electrical or hydraulic devices, components, assemblies, and sub assemblies for that function or system. You will also find all the types of information that have been written for that function or system: the technical data (specifications), the functional data (how it works), the diagnostic data (fault codes and troubleshooting), and the service data (remove, install adjust, etc.).

By integrating SAP coding into technical information, you will be able to search and retrieve just the right piece of technical information you need to resolve that customer's concern on his machine. This is made possible by attaching 3 categories to each piece of technical information during the authoring process.

The first category is the Location, the second category is the Information Type and the third category is the Product:

- LOCATION - the component or function on the machine, that the piece of technical information is going to describe (e.g., Fuel tank).
- INFORMATION TYPE - the piece of technical information that has been written for a particular component or function on the machine (e.g., Capacity would be a type of Technical Data describing the amount of fuel held by the fuel tank).
- PRODUCT - the model for which the piece of technical information is written.

Every piece of technical information will have those three categories attached to it. You will be able to use any combination of those categories to find the right piece of technical information you need to resolve that customer's concern on their machine.

That information could be:

- the procedure for how to remove the cylinder head
- a table of specifications for a hydraulic pump
- a fault code
- a troubleshooting table
- a special tool

SERVICE MANUAL

Engine



**MAXXUM 110 EP , MAXXUM 110 Multicontroller EP , MAXXUM 115 EP
 , MAXXUM 115 Multicontroller EP , MAXXUM 120 EP , MAXXUM 120
Multicontroller EP , MAXXUM 125 EP , MAXXUM 125 Multicontroller EP ,
MAXXUM 130 EP , MAXXUM 130 Multicontroller EP , MAXXUM 140 EP ,
MAXXUM 140 Multicontroller EP , MAXXUM CVX 110 , MAXXUM CVX 120
 , MAXXUM CVX 130**

Engine - Disconnect

MAXXUM 115 EP	WE
MAXXUM 115 Multicontroller EP	WE
MAXXUM 125 EP	WE
MAXXUM 125 Multicontroller EP	WE
MAXXUM 140 EP	WE
MAXXUM 140 Multicontroller EP	WE

Prior operation:

Discharge the Air conditioning system, for further information refer to **Air conditioning - Discharging (50.200)**

Prior operation:

Disconnect battery, for further information refer to **Battery - Disconnect (55.302)**

Prior operation:

Drain the engine coolant system, for further information refer to **Engine cooling system - Drain fluid (10.400)**

Prior operation:

Remove the selective catalytic reduction (SRC) muffler, for further information refer to **Selective Catalytic Reduction (SCR) muffler and catalyst - Remove (10.500)**

Prior operation:

Remove the selective catalytic reduction (SRC) coolant control valve, for further information refer to **Coolant control valve - Remove (10.500)**

⚠ WARNING

Heavy objects!

Lift and handle all heavy components using lifting equipment with adequate capacity. Always support units or parts with suitable slings or hooks. Make sure the work area is clear of all bystanders.

Failure to comply could result in death or serious injury.

W0398A

⚠ WARNING

Avoid injury!

Handle all parts carefully. Do not place your hands or fingers between parts. Use Personal Protective Equipment (PPE) as indicated in this manual, including protective goggles, gloves, and safety footwear.

Failure to comply could result in death or serious injury.

W0208A

1. Using suitable lifting equipment support the front weights.

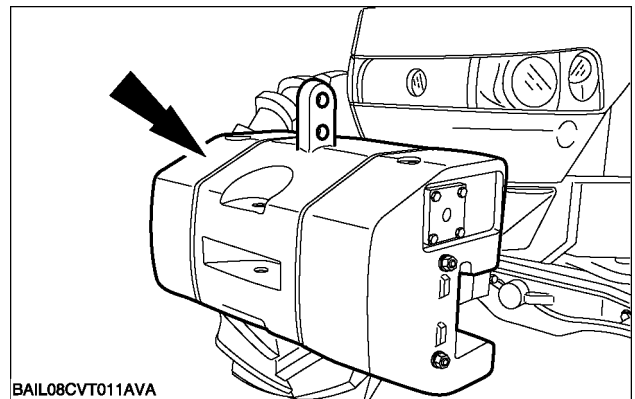

BAIL08CVT011AVA

BAIL08CVT011AVA 1

2. Disconnect and remove the front weights from the weight carrier.

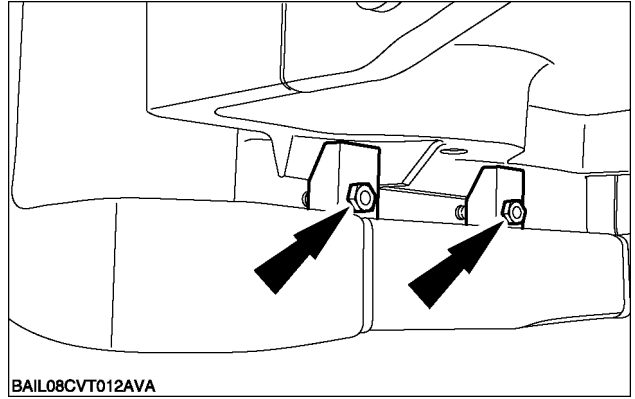

BAIL08CVT012AVA 2

3. Disconnect the radar electrical connector and remove the radar (if fitted).

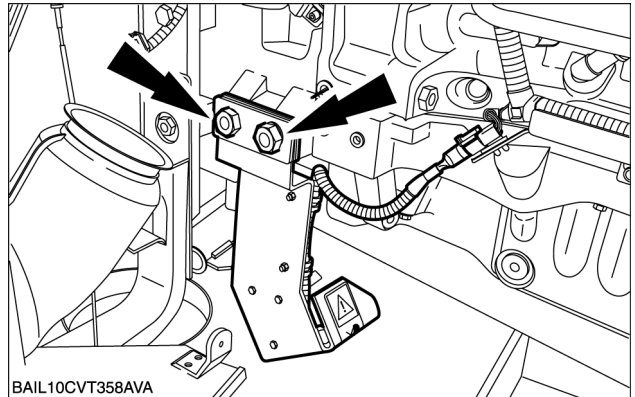

BAIL10CVT358AVA 3

4. Remove the flywheel speed sensor.

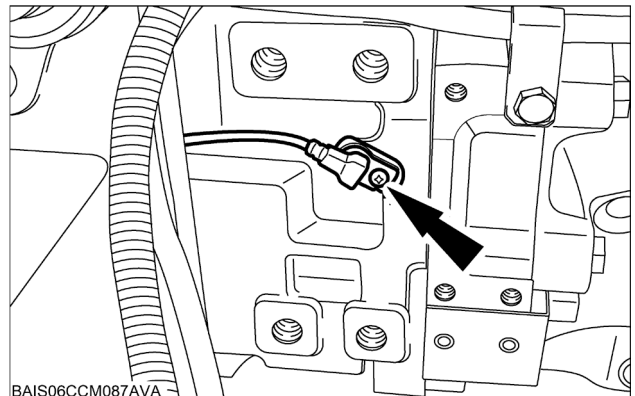

BAIS06CCM087AVA 4

5. Disconnect the engine harness electrical connectors.

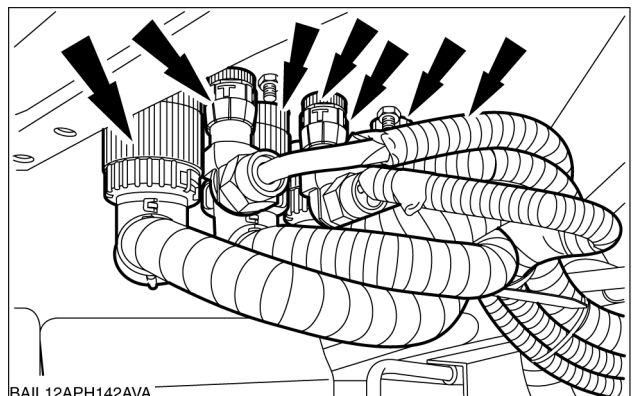

BAIL12APH142AVA 5

6. Detach the cab heater return pipe.

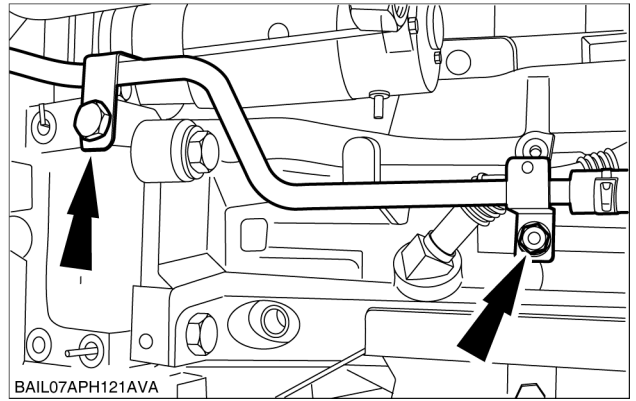

BAIL07APH121AVA 6

7. Disconnect the oil cooler supply pipes.

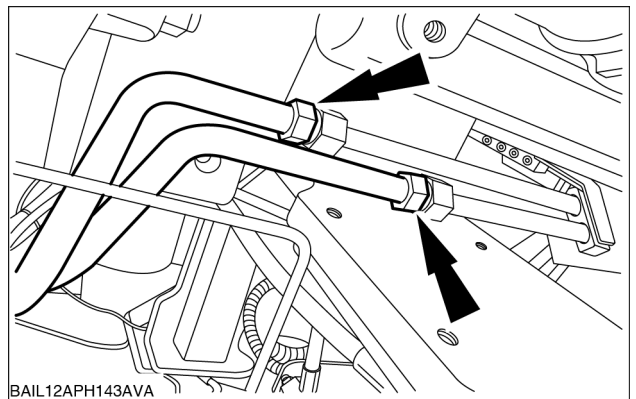

BAIL12APH143AVA 7

8. Disconnect the oil cooler supply and return pipes (1).
Remove the oil cooler pipes (2).

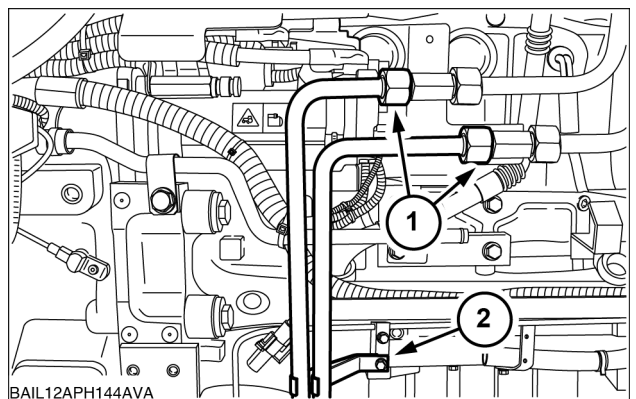

BAIL12APH144AVA 8

9. Disconnect the heater supply hose from the rear of the engine cylinder head.

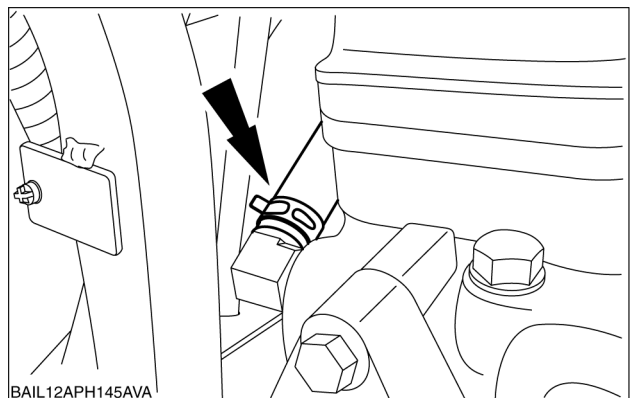

BAIL12APH145AVA 9

10. Remove the starter motor heat shield.

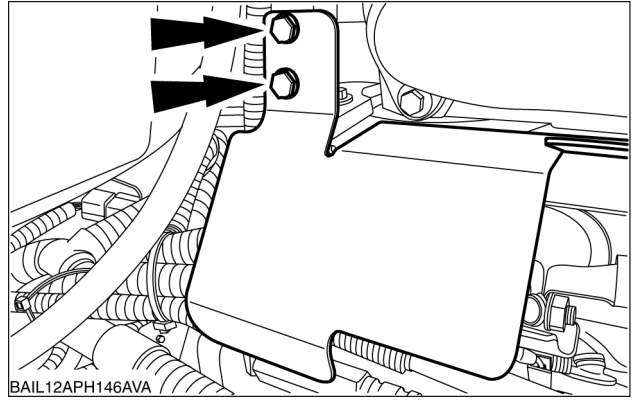

BAIL12APH146AVA

BAIL12APH146AVA 10

11. Remove the starter motor cover.

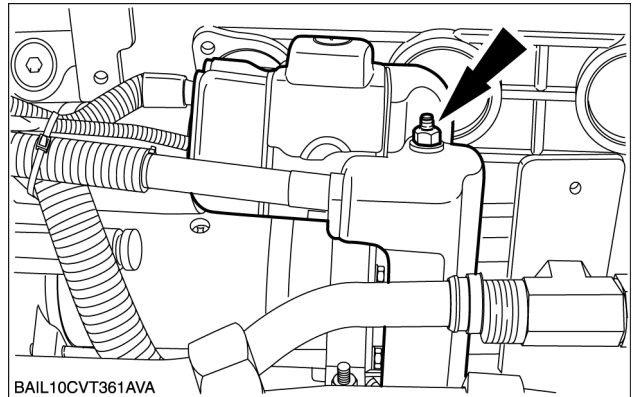

BAIL10CVT361AVA

BAIL10CVT361AVA 11

12. Disconnect the starter motor electrical connector.

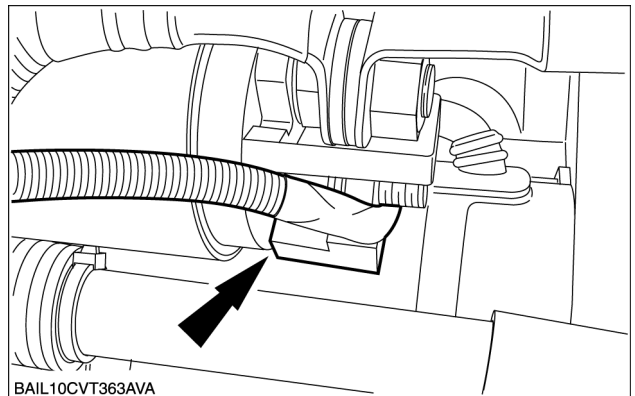

BAIL10CVT363AVA

BAIL10CVT363AVA 12

13. Disconnect the positive terminal **(1)**, negative terminal **(2)** relay and bracket **(3)** and position to one side.

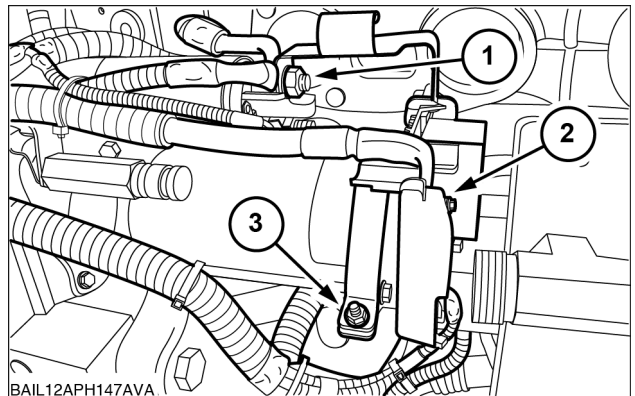

BAIL12APH147AVA

BAIL12APH147AVA 13

14. Disconnect the starter motor negative cables.

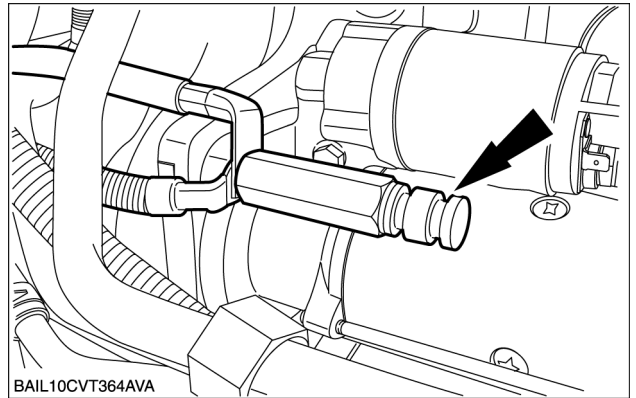

BAIL10CVT364AVA 14

15. Detach the alternator wiring harness electrical connector from the bracket (1) and detach the wiring harness (2).

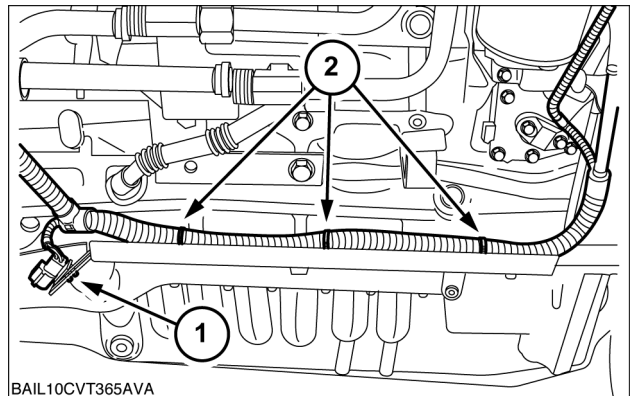

BAIL10CVT365AVA 15

16. Disconnect the alternator electrical connectors.

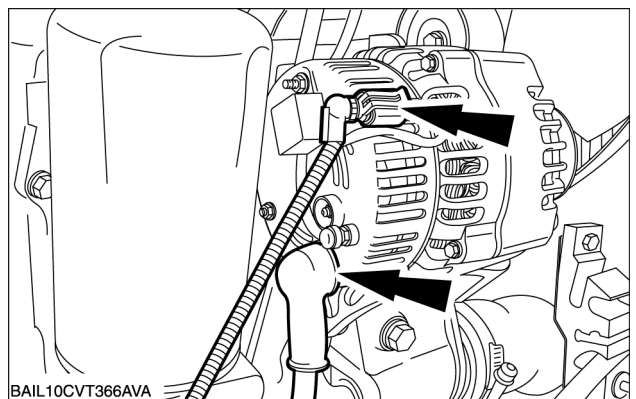

BAIL10CVT366AVA 16

17. Disconnect the brake fluid reservoir electrical connector (1) and detach the brake fluid reservoir (2) and position it to one side.

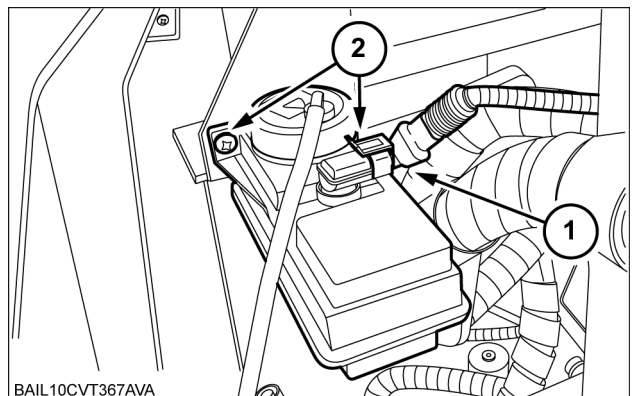

BAIL10CVT367AVA 17

18. Remove the front brake retaining bracket (1) and remove the front brake pipe (2).

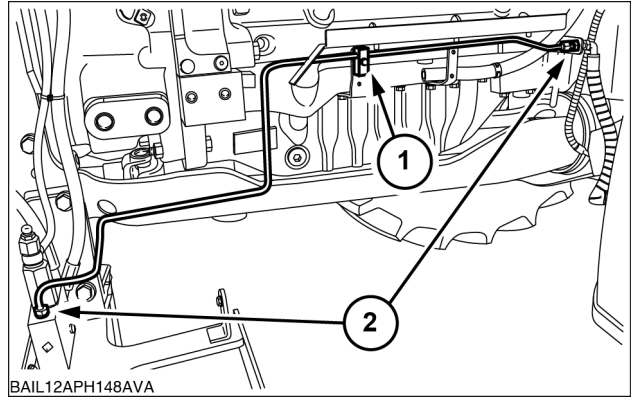

BAIL12APH148AVA

BAIL12APH148AVA 18

19. Disconnect the A/C pipe from the A/C compressor.

NOTE: Install blanking plugs/caps to all openings to prevent dirt ingress.

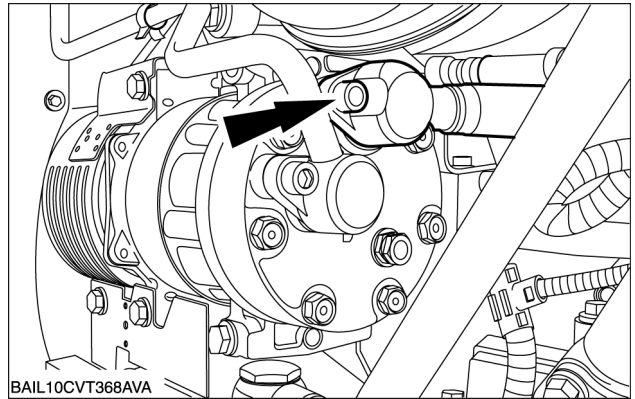

BAIL10CVT368AVA

BAIL10CVT368AVA 19

20. Disconnect the high pressure A/C pipe (1). Disconnect the low pressure switch electrical connector (2).

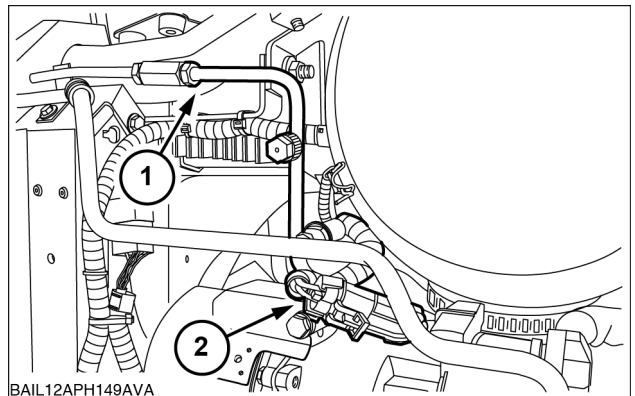

BAIL12APH149AVA

BAIL12APH149AVA 20

21. Disconnect the charge air cooler intake pipe.

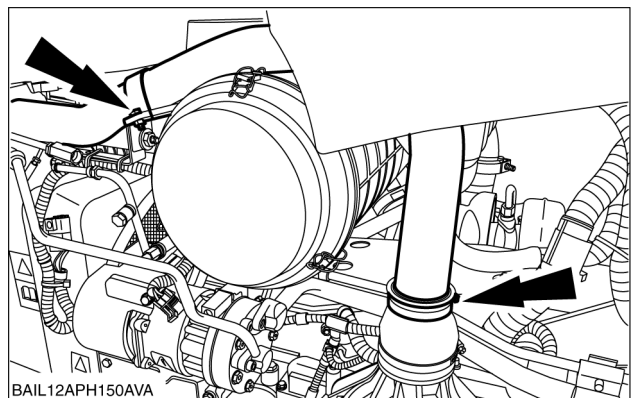

BAIL12APH150AVA

BAIL12APH150AVA 21

22. Detach the A/C pipes and position it to one side.

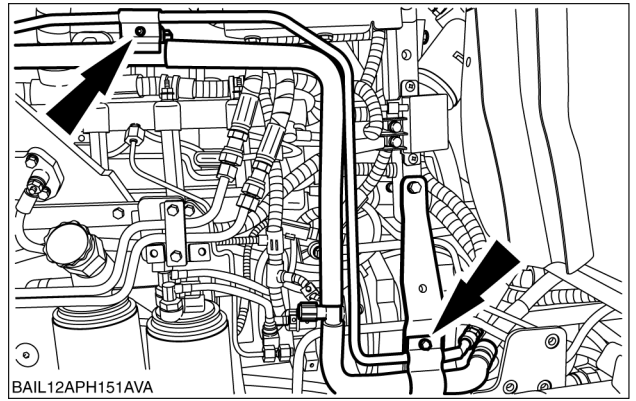

BAIL12APH151AVA

BAIL12APH151AVA 22

23. Disconnect the steering hoses.

NOTE: Mark the hoses to aid installation.

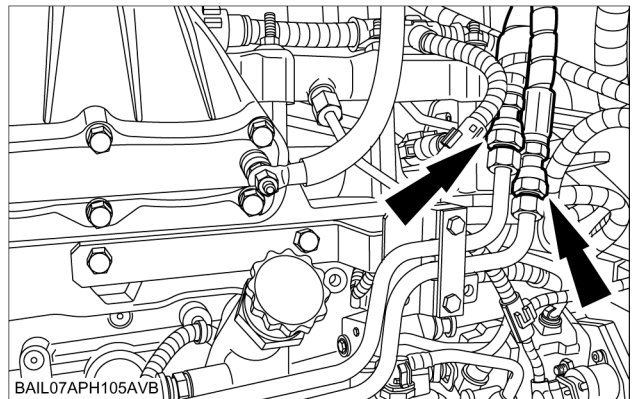

BAIL07APH105AVB

BAIL07APH105AVB 23

24. Disconnect the fuel supply line from the pre-filter/water trap.

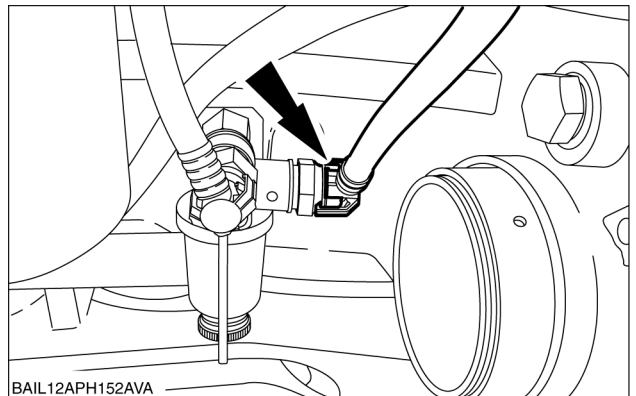

BAIL12APH152AVA

BAIL12APH152AVA 24

25. Disconnect the fuel return line (1).
Disconnect the flywheel electrical connector (2).

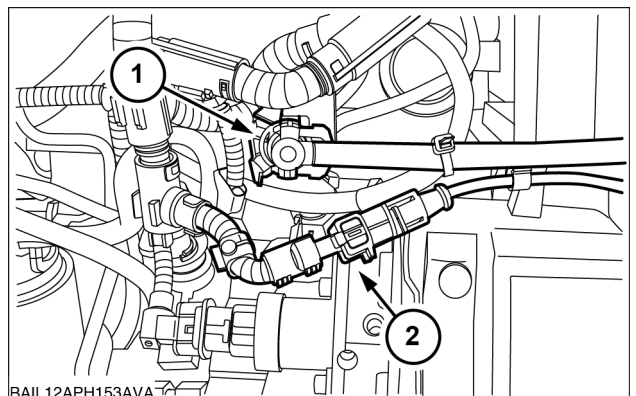

BAIL12APH153AVA

BAIL12APH153AVA 25

26. Cut the cable ties.

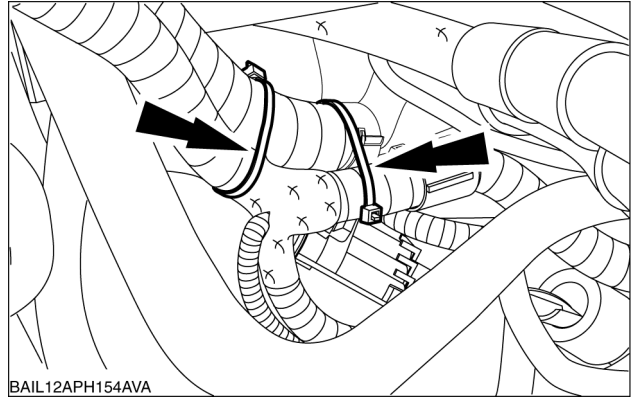

BAIL12APH154AVA 26

27. Cut the starter motor wiring harness cable ties.

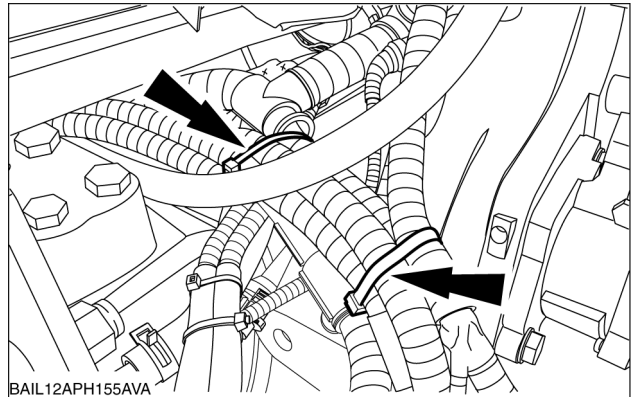

BAIL12APH155AVA 27

28. Disconnect the engine earth connector.

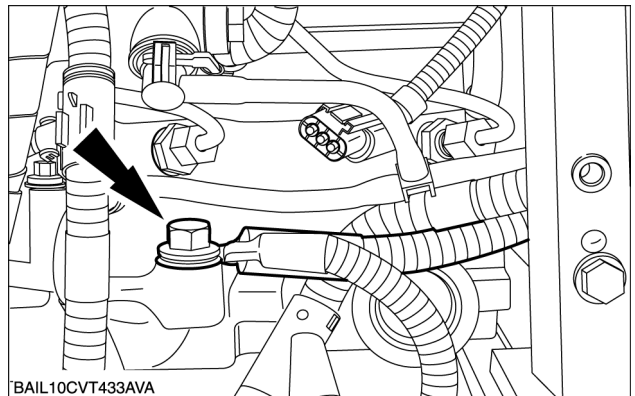

BAIL10CVT433AVA 28

29. Disconnect the diff lock supply pipe (1) and pneumatic brake supply pipe (2). Remove the pipe retaining bracket (3) and remove the pipes.

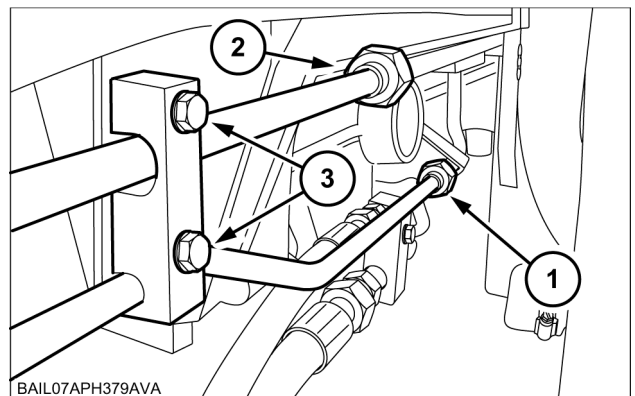

BAIL07APH379AVA 29

NOTE: Repeat the operation on both sides of the vehicle.

30.

Vehicles with standard front axle

31. Remove the front wheel drive shaft guard and drive shaft.

NOTE: The type of drive shaft fitted is dependant on type of front axle installed.

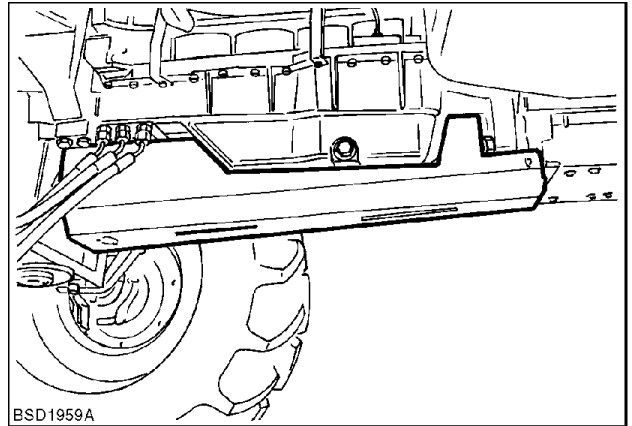

BSD1959A 30

32. Remove the drive shaft flange, where fitted.

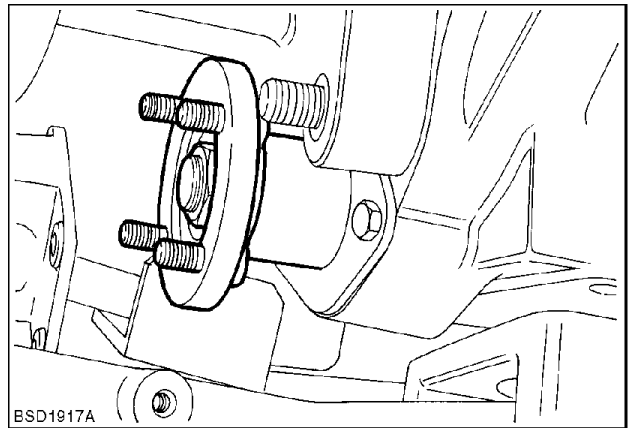

BSD1917A 31

Vehicles with suspended front axle

33. Remove the front wheel drive shaft guard.

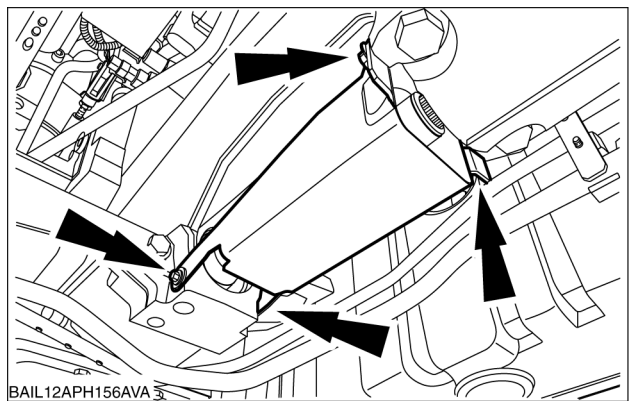

BAIL12APH156AVA 32



Suggest:

If the above button click is invalid.

Please download this document

first, and then click the above link

to download the complete manual.

Thank you so much for reading

34. Remove the circlip (1).
Slide the drive shaft sleeve (2).

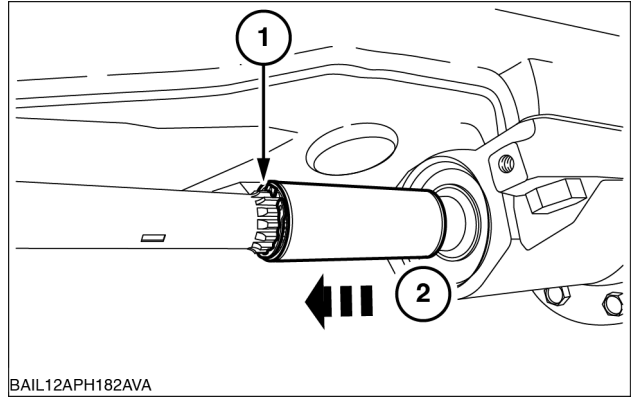

BAIL12APH182AVA 33

35. Disconnect the drive shaft bearing carrier.

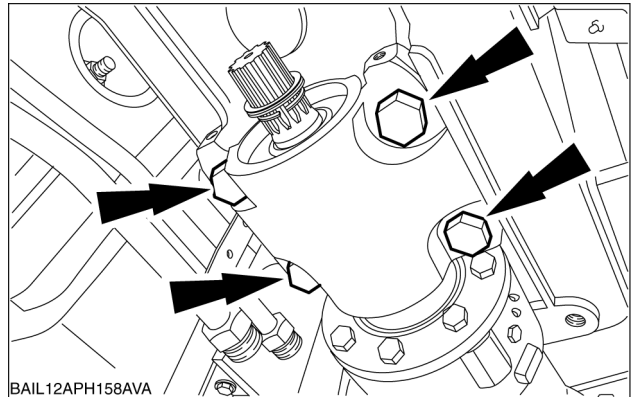

BAIL12APH158AVA 34

All vehicles

36. Using the tractor splitting equipment **380040228** Install the larger wheeled part of the splitting equipment under the front weight carrier.

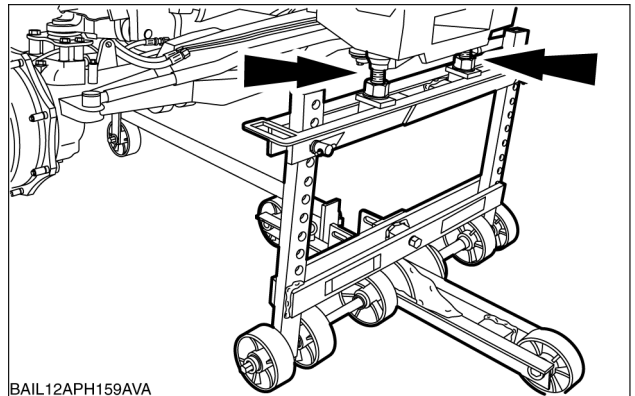

BAIL12APH159AVA 35

37. Position the static part of the splitting equipment under the transmission and secure to the transmission. Install the smaller wheeled part of the splitting equipment under the engine.

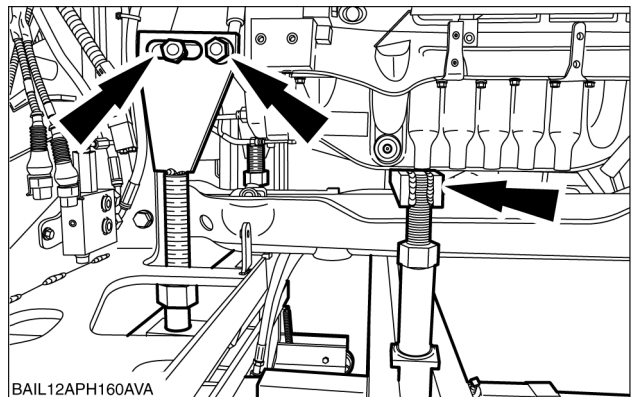

BAIL12APH160AVA 36

<https://www.ebooklibonline.com>

Hello dear friend!

Thank you very much for reading.

Enter the link into your browser.

The full manual is available for immediate download.

<https://www.ebooklibonline.com>