

Magnum™ 250

Magnum™ 280

Magnum™ 310

Magnum™ 340

Magnum™ 380

Magnum™ 310 Rowtrac™

Magnum™ 340 Rowtrac™

Magnum™ 380 Rowtrac™

**Continuously Variable Transmission (CVT)
Tractor**

PIN ZERF08100 and above

SERVICE MANUAL

Part number 47799448

1st edition English

November 2014

Copyright © 2014 CNH Industrial America LLC. All Rights Reserved.



Link Product / Engine

Product	Market Product	Engine
Magnum™ 250 696110725 CVT TIER 2 [ZERF08100 -]	Middle East Africa	F2CFA613G*E024
Magnum™ 250 696110725 CVT TIER 2 [ZERF08100 -]	Asia Pacific	F2CFA613G*E024
Magnum™ 250 696110725 CVT TIER 2 [ZERF08100 -]	Australia New Zealand	F2CFA613G*E024
Magnum™ 250 696110725 CVT TIER 2 [ZERF08100 -]	Latin America	F2CFA613G*E024
Magnum™ 280 696110735 CVT TIER 2 [ZERF08100 -]	Latin America	F2CFA613D*E024
Magnum™ 280 696110735 CVT TIER 2 [ZERF08100 -]	Middle East Africa	F2CFA613D*E024
Magnum™ 280 696110735 CVT TIER 2 [ZERF08100 -]	Australia New Zealand	F2CFA613D*E024
Magnum™ 280 696110735 CVT TIER 2 [ZERF08100 -]	Asia Pacific	F2CFA613D*E024
Magnum™ 310 696110745 CVT TIER 2 [ZERF08100 -]	Australia New Zealand	F2CFA613B*E024
Magnum™ 310 696110745 CVT TIER 2 [ZERF08100 -]	Asia Pacific	F2CFA613B*E024
Magnum™ 310 696110745 CVT TIER 2 [ZERF08100 -]	Latin America	F2CFA613B*E024
Magnum™ 310 696110745 CVT TIER 2 [ZERF08100 -]	Middle East Africa	F2CFA613B*E024
Magnum™ 340 696110755 CVT TIER 2 [ZERF08100 -]	Australia New Zealand	F2CFA614D*E022
Magnum™ 340 696110755 CVT TIER 2 [ZERF08100 -]	Latin America	F2CFA614D*E022
Magnum™ 340 696110755 CVT TIER 2 [ZERF08100 -]	Asia Pacific	F2CFA614D*E022
Magnum™ 340 696110755 CVT TIER 2 [ZERF08100 -]	Middle East Africa	F2CFA614D*E022
Magnum™ 380 696110765 CVT TIER 2 [ZERF08100 -]	Asia Pacific	F2CFA614A*E022
Magnum™ 380 696110765 CVT TIER 2 [ZERF08100 -]	Latin America	F2CFA614A*E022
Magnum™ 380 696110765 CVT TIER 2 [ZERF08100 -]	Middle East Africa	F2CFA614A*E022
Magnum™ 380 696110765 CVT TIER 2 [ZERF08100 -]	Australia New Zealand	F2CFA614A*E022
Magnum™ 310 Rowtrac™ 696110775 CVT TIER 2 [ZERF08100 -]	Asia Pacific	F2CFA613B*E024
Magnum™ 310 Rowtrac™ 696110775 CVT TIER 2 [ZERF08100 -]	Latin America	F2CFA613B*E024
Magnum™ 310 Rowtrac™ 696110775 CVT TIER 2 [ZERF08100 -]	Middle East Africa	F2CFA613B*E024

Product	Market Product	Engine
Magnum™ 310 Rowtrac™ 696110775 CVT TIER 2 [ZERF08100 -]	Australia New Zealand	F2CFA613B*E024
Magnum™ 340 Rowtrac™ 696110785 CVT TIER 2 [ZERF08100 -]	Asia Pacific	F2CFA614D*E022
Magnum™ 340 Rowtrac™ 696110785 CVT TIER 2 [ZERF08100 -]	Latin America	F2CFA614D*E022
Magnum™ 340 Rowtrac™ 696110785 CVT TIER 2 [ZERF08100 -]	Middle East Africa	F2CFA614D*E022
Magnum™ 340 Rowtrac™ 696110785 CVT TIER 2 [ZERF08100 -]	Australia New Zealand	F2CFA614D*E022
Magnum™ 380 Rowtrac™ 696110795 CVT TIER 2 [ZERF08100 -]	Asia Pacific	F2CFA614A*E022
Magnum™ 380 Rowtrac™ 696110795 CVT TIER 2 [ZERF08100 -]	Middle East Africa	F2CFA614A*E022
Magnum™ 380 Rowtrac™ 696110795 CVT TIER 2 [ZERF08100 -]	Australia New Zealand	F2CFA614A*E022
Magnum™ 380 Rowtrac™ 696110795 CVT TIER 2 [ZERF08100 -]	Latin America	F2CFA614A*E022

<https://www.ebooklibonline.com>

Hello dear friend!

Thank you very much for reading.

Enter the link into your browser.

The full manual is available for immediate download.

<https://www.ebooklibonline.com>

Contents

INTRODUCTION

Engine.....	10
[10.001] Engine and crankcase	10.1
[10.101] Cylinder heads	10.2
[10.202] Air cleaners and lines	10.3
[10.216] Fuel tanks	10.4
[10.218] Fuel injection system.....	10.5
[10.254] Intake and exhaust manifolds and muffler	10.6
[10.304] Engine lubrication system.....	10.7
[10.310] Aftercooler.....	10.8
[10.400] Engine cooling system	10.9
[10.414] Fan and drive	10.10
Power coupling.....	19
[19.100] Drive shaft.....	19.1
[19.110] Flywheel damper	19.2
[19.120] Drive shaft shield assembly	19.3
Transmission.....	21
[21.504] Continuously Variable Transmission (CVT)	21.1
[21.505] Continuously Variable Transmission (CVT) external controls.....	21.2
[21.506] Continuously Variable Transmission (CVT) lubrication system	21.3
[21.507] Continuously Variable Transmission (CVT) internal components.....	21.4
[21.900] Hydraulic pump drive.....	21.5
Four-Wheel Drive (4WD) system	23
[23.202] Electro-hydraulic control	23.1
[23.314] Drive shaft.....	23.2
Front axle system	25

[25.100] Powered front axle	25.1
[25.102] Front bevel gear set and differential	25.2
[25.108] Final drive hub, steering knuckles, and shafts	25.3
[25.122] Axle suspension control	25.4
Rear axle system	27
[27.100] Powered rear axle	27.1
[27.106] Rear bevel gear set and differential	27.2
[27.610] Rear axle track yoke assembly	27.3
Power Take-Off (PTO)	31
[31.104] Rear electro-hydraulic control	31.1
[31.110] One-speed rear Power Take-Off (PTO)	31.2
[31.114] Two-speed rear Power Take-Off (PTO)	31.3
[31.146] Front Power Take-Off (PTO)	31.4
Brakes and controls	33
[33.110] Parking brake or parking lock	33.1
[33.202] Hydraulic service brakes	33.2
[33.220] Trailer brake hydraulic control	33.3
[33.224] Trailer brake pneumatic control	33.4
[33.240] Emergency brake	33.5
Hydraulic systems	35
[35.000] Hydraulic systems	35.1
[35.102] Pump control valves	35.2
[35.106] Variable displacement pump	35.3
[35.114] Three-point hitch control valve	35.4
[35.124] Three-point hitch hydraulic adjustment	35.5
[35.204] Remote control valves	35.6
[35.300] Reservoir, cooler, and filters	35.7
[35.304] Combination pump units	35.8

Hitches, drawbars, and implement couplings.....	37
[37.110] Rear three-point hitch	37.1
[37.162] Front hitch	37.2
Steering.....	41
[41.101] Steering control	41.1
[41.200] Hydraulic control components.....	41.2
[41.206] Pump	41.3
[41.432] Autoguidance steering	41.4
[41.910] Auxiliary steering	41.5
Wheels	44
[44.520] Rear wheels.....	44.1
Tracks and track suspension	48
[48.100] Tracks	48.1
[48.130] Track frame and driving wheels	48.2
[48.134] Track tension units	48.3
[48.138] Track rollers	48.4
Cab climate control	50
[50.100] Heating.....	50.1
[50.200] Air conditioning	50.2
[50.300] Cab pressurizing system.....	50.3
Electrical systems	55
[55.010] Fuel injection system	55.1
[55.012] Engine cooling system	55.2
[55.014] Engine intake and exhaust system.....	55.3
[55.024] Transmission control system.....	55.4
[55.045] Front axle control system	55.5
[55.046] Rear axle control system.....	55.6
[55.050] Heating, Ventilation, and Air-Conditioning (HVAC) control system.....	55.7

[55.051] Cab Heating, Ventilation, and Air-Conditioning (HVAC) controls.....	55.8
[55.100] Harnesses and connectors.....	55.9
[55.130] Rear three-point hitch electronic control system	55.10
[55.201] Engine starting system	55.11
[55.301] Alternator.....	55.12
[55.302] Battery.....	55.13
[55.510] Cab or platform harnesses and connectors.....	55.14
[55.512] Cab controls.....	55.15
[55.513] Cab transmission controls.....	55.16
[55.518] Wiper and washer system.....	55.17
[55.640] Electronic modules	55.18
[55.988] Selective Catalytic Reduction (SCR) electrical system	55.19
[55.DTC] FAULT CODES.....	55.20
Platform, cab, bodywork, and decals.....	90
[90.100] Engine hood and panels	90.1
[90.102] Engine shields, hood latches, and trims	90.2
[90.124] Pneumatically-adjusted operator seat.....	90.3
[90.150] Cab.....	90.4
[90.151] Cab interior.....	90.5
[90.160] Cab interior trim and panels.....	90.6



INTRODUCTION

Foreword - Important notice regarding equipment servicing

All repair and maintenance work listed in this manual must be carried out only by qualified dealership personnel, strictly complying with the instructions given, and using, whenever possible, the special tools.

Anyone who performs repair and maintenance operations without complying with the procedures provided herein shall be responsible for any subsequent damages.

The manufacturer and all the organizations of its distribution chain, including - without limitation - national, regional, or local dealers, reject any responsibility for damages caused by parts and/or components not approved by the manufacturer, including those used for the servicing or repair of the product manufactured or marketed by the manufacturer. In any case, no warranty is given or attributed on the product manufactured or marketed by the manufacturer in case of damages caused by parts and/or components not approved by the manufacturer.

The information in this manual is up-to-date at the date of the publication. It is the policy of the manufacturer for continuous improvement. Some information could not be updated due to modifications of a technical or commercial type, or changes to the laws and regulations of different countries.

In case of questions, refer to your CASE IH Sales and Service Networks.

Safety rules

Personal safety



This is the safety alert symbol. It is used to alert you to potential personal injury hazards. Obey all safety messages that follow this symbol to avoid possible death or injury.

Throughout this manual you will find the signal words DANGER, WARNING, and CAUTION followed by special instructions. These precautions are intended for the personal safety of you and those working with you.

Read and understand all the safety messages in this manual before you operate or service the machine.

 DANGER indicates a hazardous situation that, if not avoided, will result in death or serious injury.

 WARNING indicates a hazardous situation that, if not avoided, could result in death or serious injury.

 CAUTION indicates a hazardous situation that, if not avoided, could result in minor or moderate injury.

FAILURE TO FOLLOW DANGER, WARNING, AND CAUTION MESSAGES COULD RESULT IN DEATH OR SERIOUS INJURY.

Machine safety

NOTICE: Notice indicates a situation that, if not avoided, could result in machine or property damage.

Throughout this manual you will find the signal word Notice followed by special instructions to prevent machine or property damage. The word Notice is used to address practices not related to personal safety.

Information

NOTE: Note indicates additional information that clarifies steps, procedures, or other information in this manual.

Throughout this manual you will find the word Note followed by additional information about a step, procedure, or other information in the manual. The word Note is not intended to address personal safety or property damage.

Safety rules - General maintenance safety

General maintenance safety

Keep the area used for servicing the machine clean and dry. Clean up spilled fluids.

Service the machine on a firm, level surface.

Install guards and shields after you service the machine.

Close all access doors and install all panels after servicing the machine.

Do not attempt to clean, lubricate, clear obstructions, or make adjustments to the machine while it is in motion or while the engine is running.

Always make sure that working area is clear of tools, parts, other persons and pets before you start operating the machine.

Unsupported hydraulic cylinders can lose pressure and drop the equipment, causing a crushing hazard. Do not leave equipment in a raised position while parked or during service, unless the equipment is securely supported.

Jack or lift the machine only at jack or lift points indicated in this manual.

Incorrect towing procedures can cause accidents. When you tow a disabled machine follow the procedure in this manual. Use only rigid tow bars.

Stop the engine, remove the key, and relieve pressure before you connect or disconnect fluid lines.

Stop the engine and remove the key before you connect or disconnect electrical connections.

Scalding can result from incorrect removal of coolant caps. Cooling systems operate under pressure. Hot coolant can spray out if you remove a cap while the system is hot. Allow the system to cool before you remove the cap. When you remove the cap, turn it slowly to allow pressure to escape before you completely remove the cap.

Replace damaged or worn tubes, hoses, electrical wiring, etc.

The engine, transmission, exhaust components, and hydraulic lines may become hot during operation. Take care when you service such components. Allow surfaces to cool before you handle or disconnect hot components. Wear protective equipment when appropriate.

When welding, follow the instructions in the manual. Always disconnect the battery before you weld on the machine. Always wash your hands after you handle battery components.



SERVICE MANUAL

Engine

Magnum™ 250 696110725 CVT TIER 2 [ZERF08100 -], Magnum™ 280 696110735 CVT TIER 2 [ZERF08100 -], Magnum™ 310 696110745 CVT TIER 2 [ZERF08100 -], Magnum™ 310 Rowtrac™ 696110775 CVT TIER 2 [ZERF08100 -], Magnum™ 340 696110755 CVT TIER 2 [ZERF08100 -], Magnum™ 340 Rowtrac™ 696110785 CVT TIER 2 [ZERF08100 -], Magnum™ 380 696110765 CVT TIER 2 [ZERF08100 -], Magnum™ 380 Rowtrac™ 696110795 CVT TIER 2 [ZERF08100 -]

Engine - Remove

Prior operation:

Disconnect the batteries — **Battery - Disconnect (55.302)**

Prior operation:

Remove the hood — **Hood - Remove (90.100)**

Prior operation:

Side shield - Remove (90.102)

Prior operation:

Recover the refrigerant — **Air conditioning - Recover (50.200)**

Prior operation:

Drain the coolant — **Engine cooling system - Emptying (10.400)**

Prior operation:

Engine cooling system - Remove (10.400)

NOTE: Clean all fittings before disconnecting.

NOTE: Cap or plug all lines and ports when disconnecting hydraulic components.

1. Disconnect the harness connector to the humidity sensor (1) and the air restriction sensor (2). Disengage the hose clamp (3) and disconnect the hose from the air intake tube.

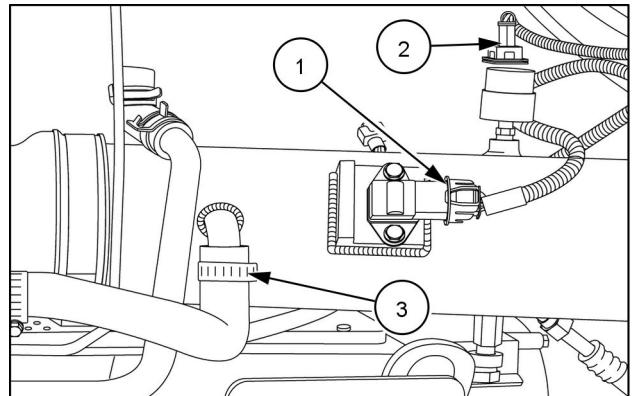

RAIL13TR04202AA 1

2. Disconnect the clamps (1) from each end of the air intake tube and remove the tube.

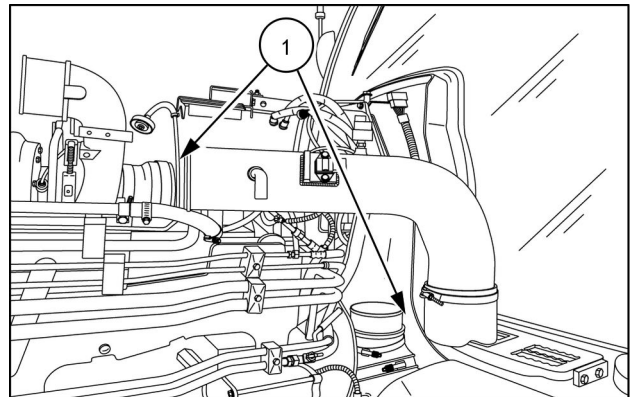

RAIL13TR04211AA 2

3. Disconnect the high pressure air conditioning hose (1) and the coolant lines (2). Plug or cap all ports and lines.

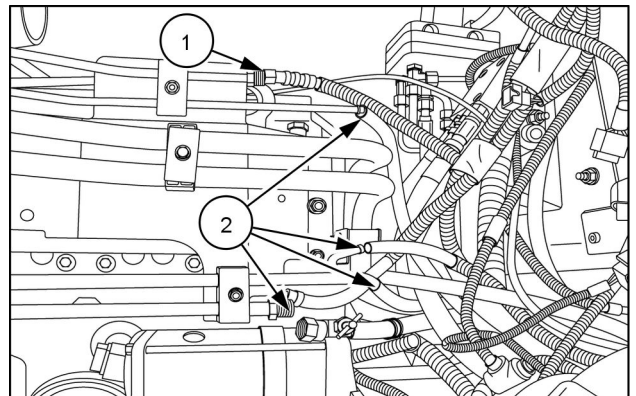

RAIL13TR04230AA 3

4. Disconnect the power cable **(1)**, the ground cable **(2)** and the ignition wire **(3)** from the starter.

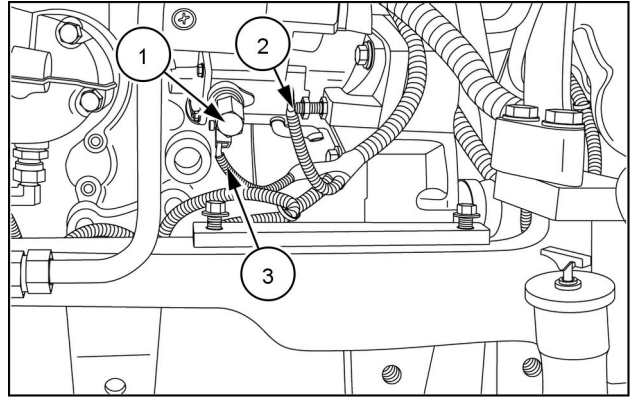

RAIL14TR01944AA 4

5. Disconnect the suspended axle harness connectors **(1)** if equipped.

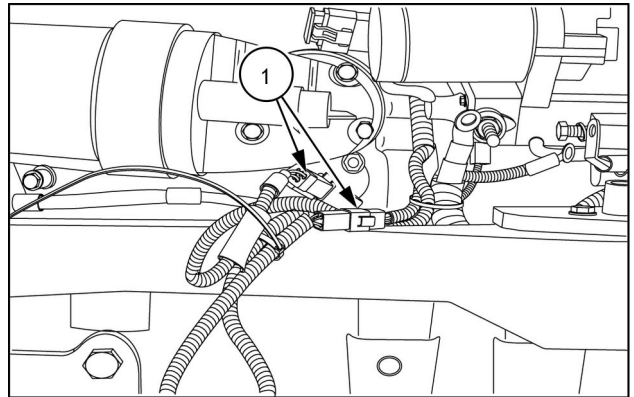

RAIL13TR04237AA 5

6. Remove the two bolts **(1)** from the rear engine mount cover plate on both sides, (left hand side shown).

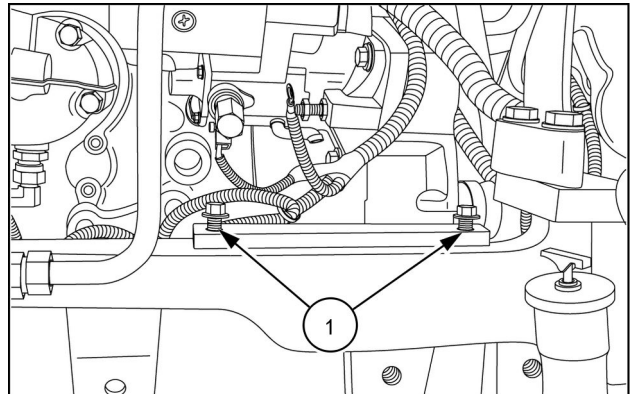

RAIL14TR01944AA 6

7. Remove the engine mount cover plate (left hand side).

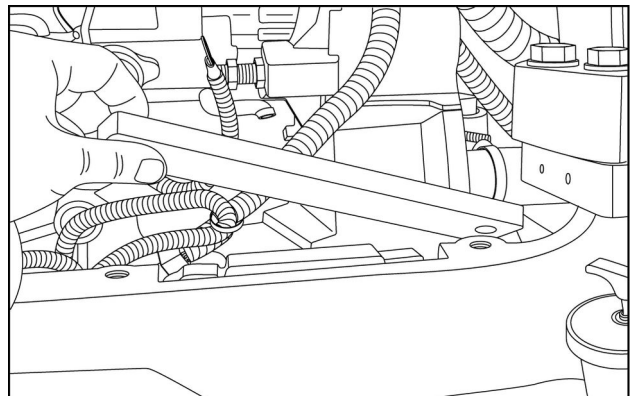

RAIL14TR01945AA 7

8. Remove the two tube clamps **(1)** securing the hydraulic cooler tubes.

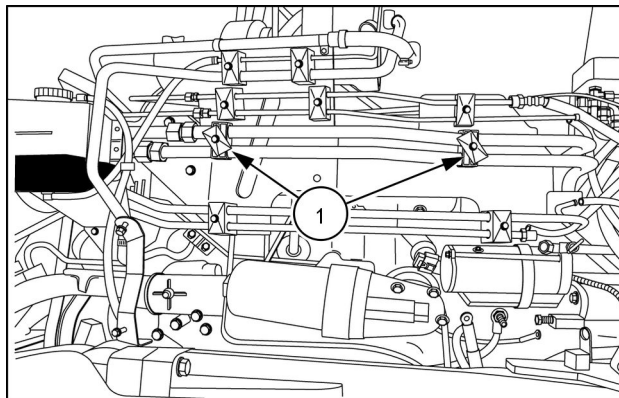

RAIL13TR04232AA 8

9. At the front of the engine, remove the tube clamp **(1)** for the oil cooler tube.

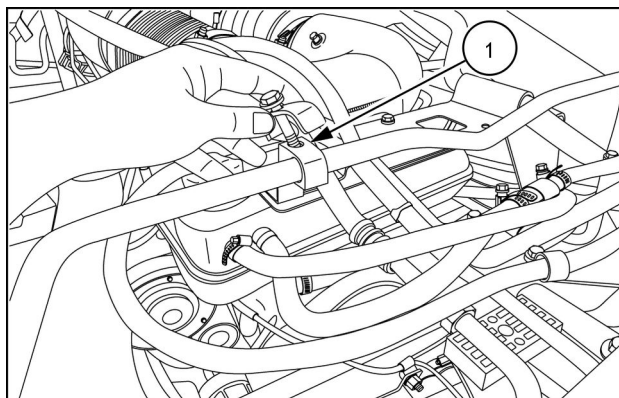

RAIL14TR01915AA 9

10. Using special tool **380000795 (1)**, disconnect the hydraulic tubes and set them aside.

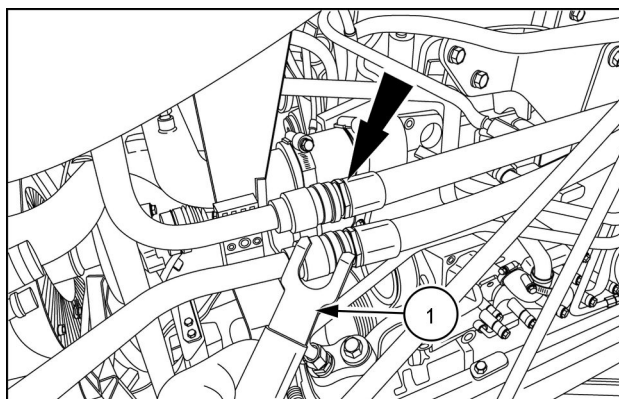

RAIL14TR01924AA 10

11. At the rear of the engine, remove the oil cooler tube clamp **(1)**.

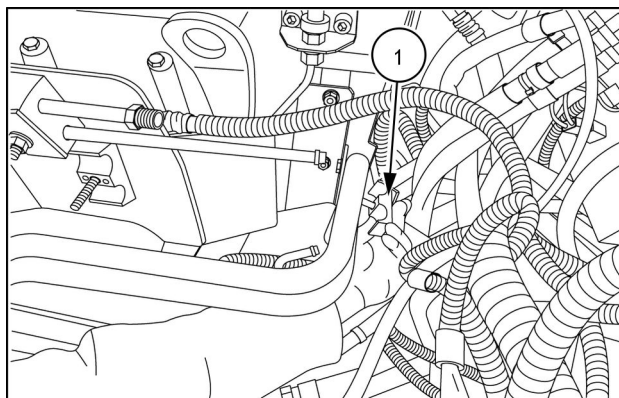

RAIL13TR04236AA 11

12. Disconnect the low pressure air conditioning line (1). Plug or cap the fittings.

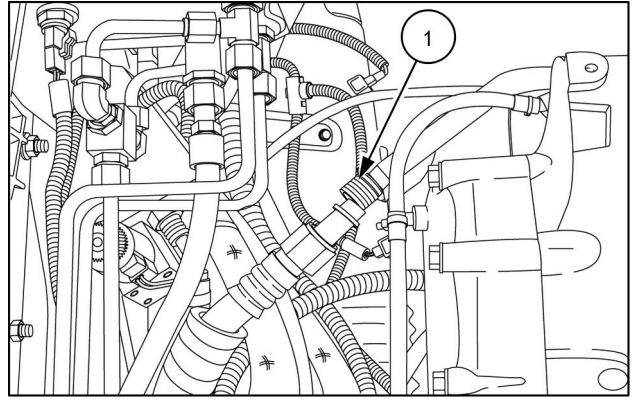

RAIL13TR04228AA 12

13. Disengage the hose clamp and disconnect the engine controller oil line (1).

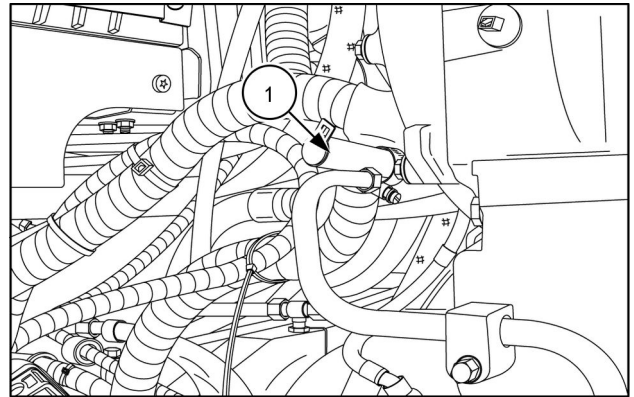

RAIL13TR04227AA 13

14. Remove the three mounting bolts (1) securing the fuse panel bracket.

NOTE: Cut and remove any wire ties securing the harness.

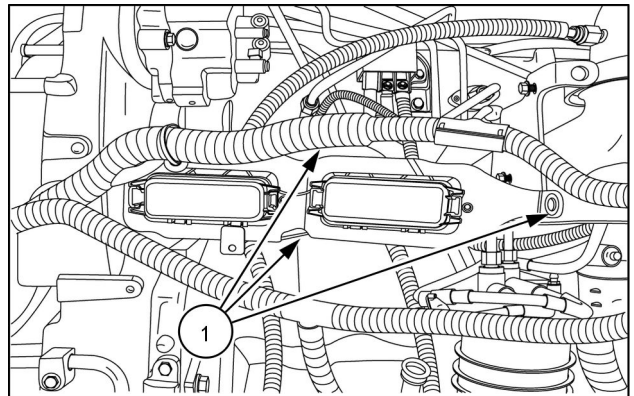

RAIL13TR04216AA 14

15. Remove the fuse panel and set to the side.

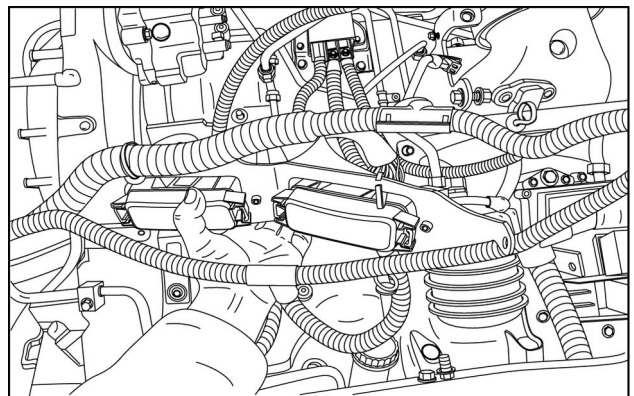

RAIL13TR04214AA 15

16. Disconnect the harness connector **(1)** for the engine grid heater and the power supply cable **(2)**.

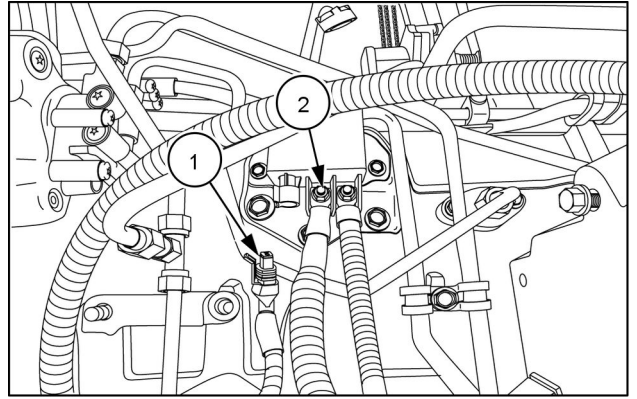

RAIL13TR04219AA 16

17. Disconnect the vent hose **(1)** from the intake manifold.

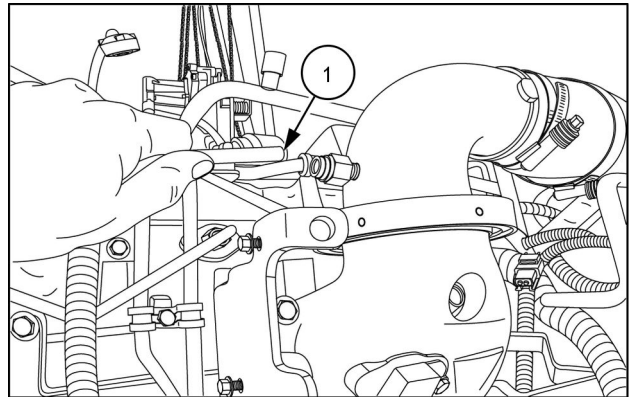

RAIL13TR04218AA 17

18. Disconnect the harness connector **(1)** for the fan drive.

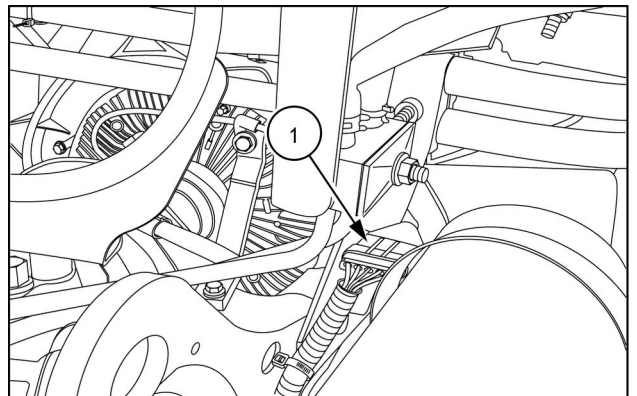

RAIL13TR04220AA 18

19. Remove the air conditioning compressor mounting bolt **(1)**, and disconnect the ground wire **(2)**.

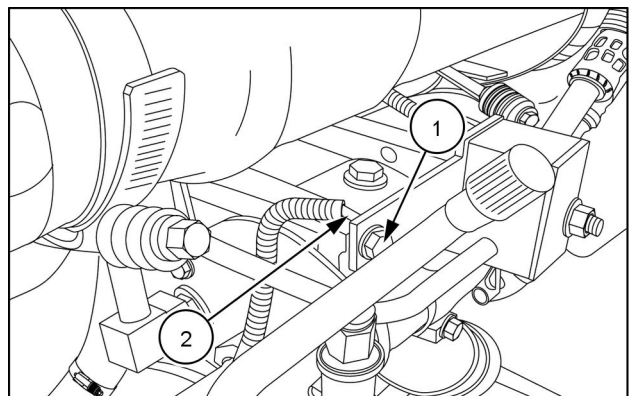

RAIL13TR04224AA 19

20. Disconnect the harness connector to the high pressure switch (1).

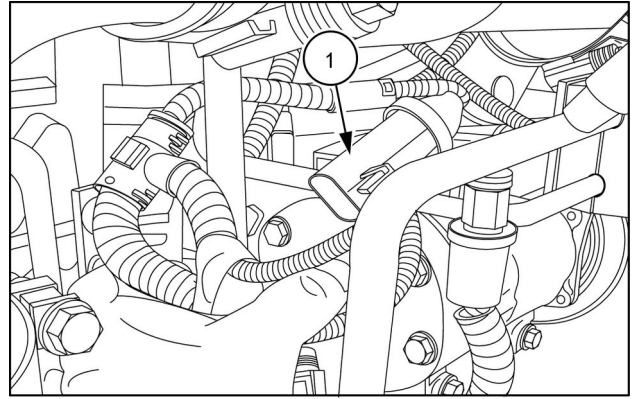

RAIL13TR04223AA 20

21. Disconnect the alternator excite wire connector (1) and the CAN bus connector (2).

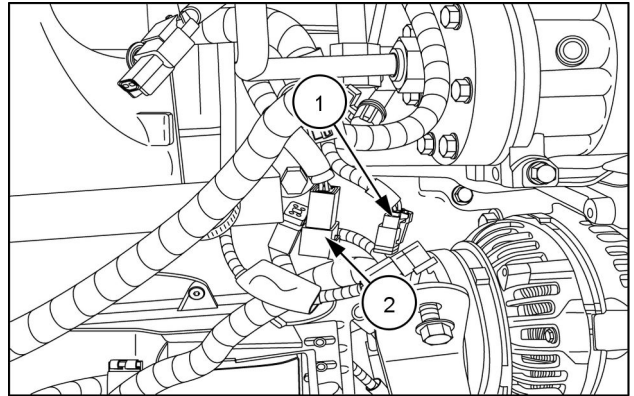

RAIL13TR04221AA 21

22. Remove the nut and disconnect the alternator output cable (1).

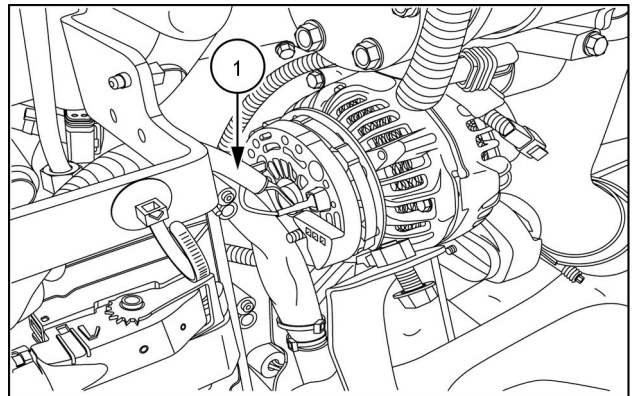

RAIL13TR04231AA 22

23. Disconnect the harness connector (1) to the engine controller.

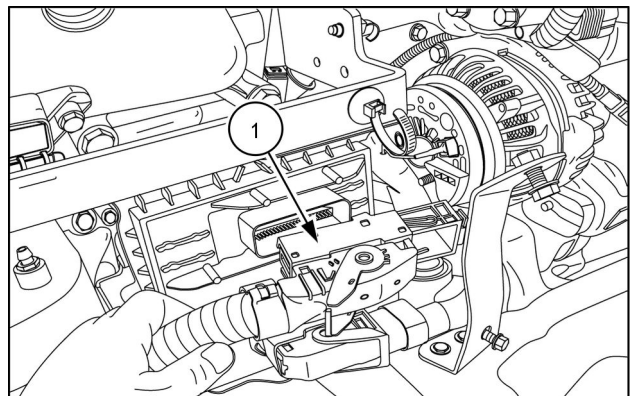

RAIL13TR04226AA 23

24. Remove the bolts (1) and the drive shaft cover. Set the cover aside.

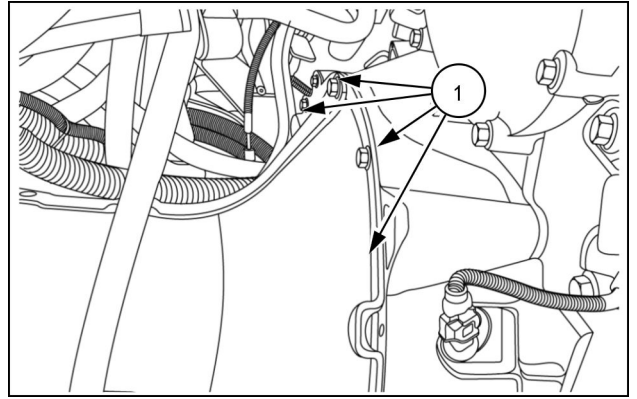

RCPH10CCH813AAB 24

25. Mark the alignment of the drive shaft (1). Remove the four bolts and remove the drive shaft from the fly-wheel.

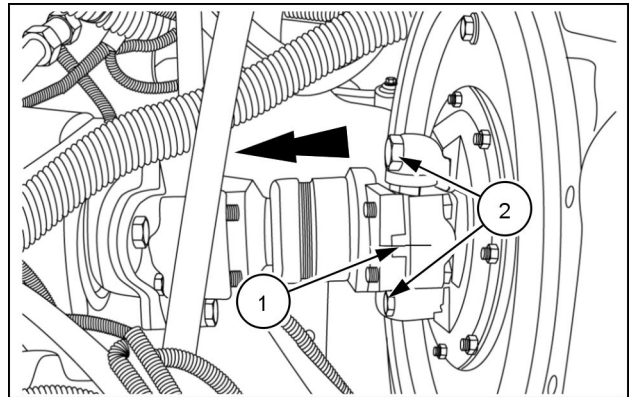

RCPH10CCH817AAB 25

26. Remove the bolts (1) from the plate (2) for the right hand rear engine mount.

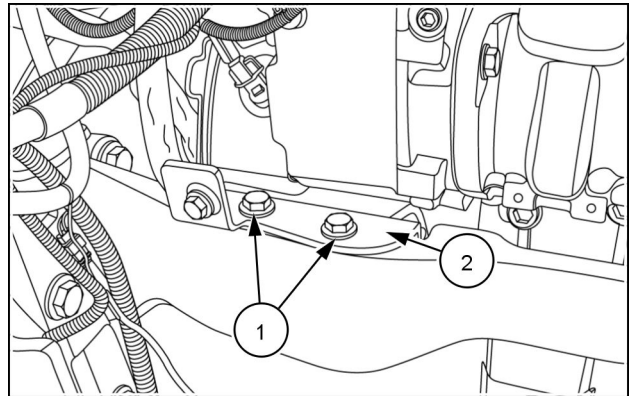

RCPH10CCH925AAB 26

27. Under the front frame, remove the front engine mount nut.

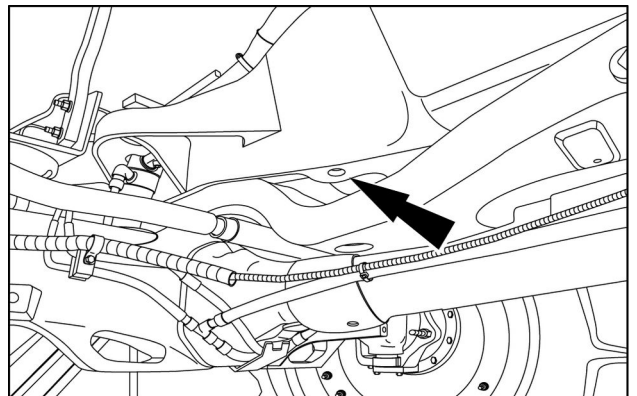

RAIL13TR04246AA 27

28. **⚠ WARNING**

Heavy objects!
Lift and handle all heavy components using lifting equipment with adequate capacity. Always support units or parts with suitable slings or hooks. Make sure the work area is clear of all bystanders. Failure to comply could result in death or serious injury.

W0398A

Use an appropriate device to support the engine, and carefully remove the engine making sure all hoses, lines and harnesses are disconnected.

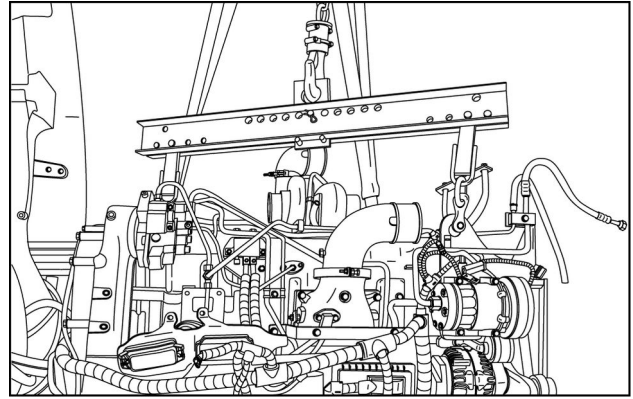

RAIL14TR01947AA 28

29. Remove the right hand rear engine mount. Inspect for wear and/or damage. Replace as required. Repeat for the left side.

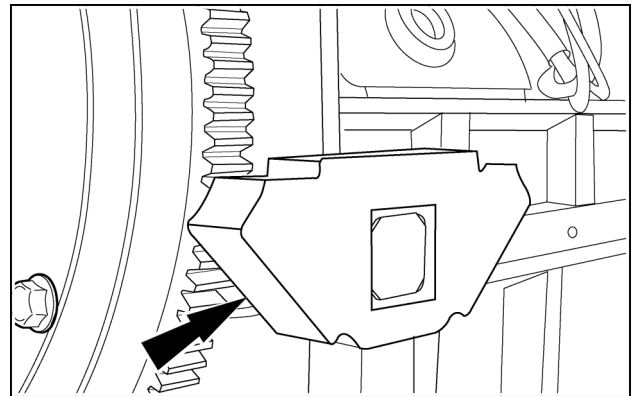

RCPH07CCH166AAB 29

30. Remove the four bolts (1) securing the brackets (2) for the front engine mount.
31. Remove the bolt (3) securing the front engine mount (4).
32. Inspect the mount for wear and/or damage. Replace as required.

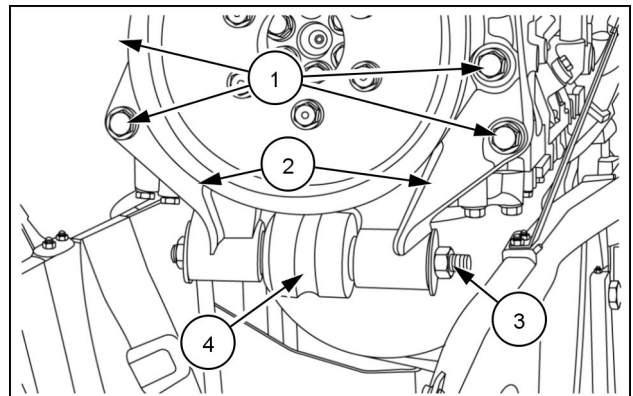

RCPH10CCH833AAB 30

Next operation:
Engine - Install (10.001)



Suggest:

If the above button click is invalid.

Please download this document

first, and then click the above link

to download the complete manual.

Thank you so much for reading

Engine - Install

Prior operation: Engine - Remove (10.001)

1. If removed, install the front engine mounting brackets (1).
2. Torque the four mounting bolts (2) to **101 - 113 N·m (75 - 83 lb ft)**.
3. Torque the ISO mount support bolt nut (3) to **160 - 220 N·m (118 - 162 lb ft)**.

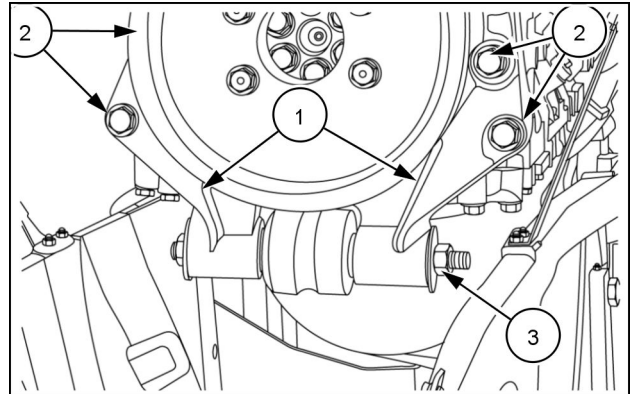

RCPH10CCH833AAB 1

4. Install the right hand (shown) and left hand rear engine ISO mounts.

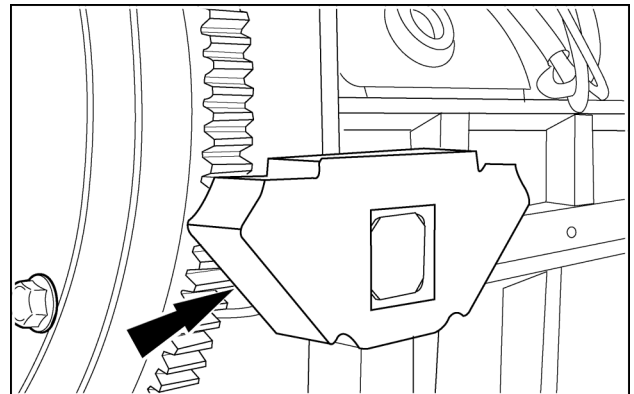

RCPH07CCH166AAB 2

5. **⚠ WARNING**

Heavy objects!
Lift and handle all heavy components using lifting equipment with adequate capacity. Always support units or parts with suitable slings or hooks. Make sure the work area is clear of all bystanders.
Failure to comply could result in death or serious injury.

W0398A

Properly support the engine. Raise and move the engine into the front support frame.

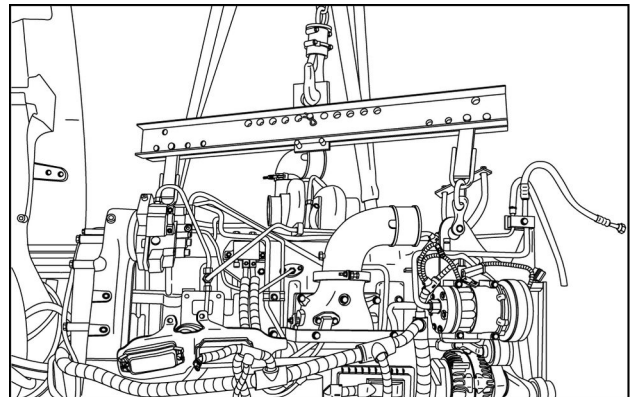

RAIL14TR01947AA 3

6. Install the front engine mounting nut.

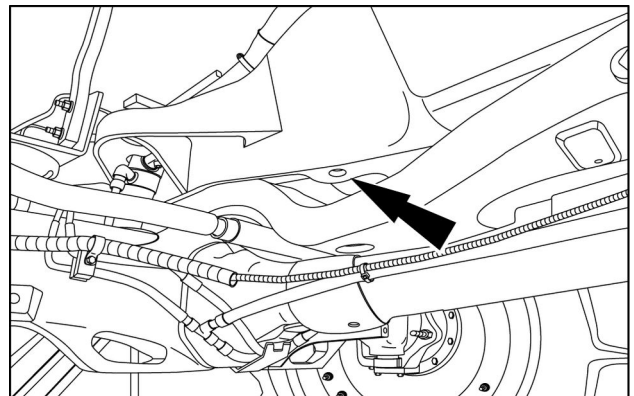

RAIL13TR04246AA 4

<https://www.ebooklibonline.com>

Hello dear friend!

Thank you very much for reading.

Enter the link into your browser.

The full manual is available for immediate download.

<https://www.ebooklibonline.com>