

**Magnum 235**  
**Magnum 260**  
**Magnum 290**  
**Magnum 315**  
**Magnum 340**  
Tractor

*PIN ZBRD07000 and after*

**SERVICE MANUAL**

Part number 47386174

English

October 2012

Copyright © 2012 CNH America LLC. All Rights Reserved.



## **SERVICE MANUAL**

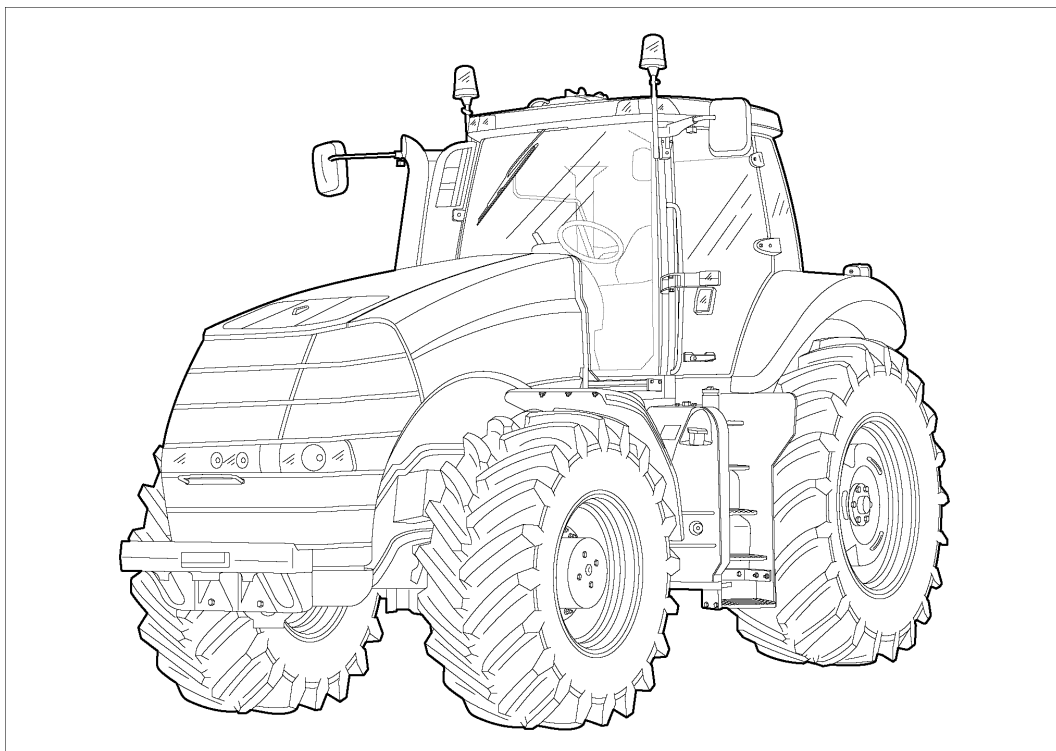

**Magnum 235 [ZBRD07000 - ] , Magnum 260 [ZBRD07000 - ]  
Magnum 290 [ZBRD07000 - ] , Magnum 315 [ZBRD07000 - ] ,  
Magnum 340 [ZBRD07000 - ]**

# Contents

---

## INTRODUCTION

Engine.....	10
Engine and crankcase.....	10.001
Cylinder heads .....	10.101
Pump drives .....	10.114
Air cleaners and lines.....	10.202
Fuel tanks .....	10.216
Aftercooler.....	10.310
Engine cooling system .....	10.400
Fan and drive.....	10.414
Selective Catalytic Reduction (SCR) exhaust treatment .....	10.500
Transmission.....	21
Powershift transmission lubrication system .....	21.105
Powershift transmission .....	21.113
Powershift transmission external controls .....	21.135
Gearbox internal components .....	21.145
Powershift transmission internal components.....	21.155
Drop box.....	21.200
Four-Wheel Drive (4WD) system .....	23
Electrohydraulic control.....	23.202
Drive shaft .....	23.314
Front axle system .....	25
Powered front axle .....	25.100
Front bevel gear set and differential .....	25.102
Final drive hub, steering knuckles, and shafts .....	25.108
Axle suspension control .....	25.122
Rear axle system.....	27

**<https://www.ebooklibonline.com>**

Hello dear friend!

Thank you very much for reading.

Enter the link into your browser.

The full manual is available for immediate download.

**<https://www.ebooklibonline.com>**

Powered rear axle .....	27.100
Rear bevel gear set and differential .....	27.106
Planetary and final drives.....	27.120
<b>Power Take-Off (PTO) .....</b>	<b>31</b>
Rear electrohydraulic control .....	31.104
One-speed rear Power Take-Off (PTO) .....	31.110
Two-speed rear Power Take-Off (PTO) .....	31.114
Front Power Take-Off (PTO).....	31.146
<b>Brakes and controls .....</b>	<b>33</b>
Parking brake / Parking lock.....	33.110
Hydraulic service brakes .....	33.202
Trailer brake hydraulic control .....	33.220
Trailer brake pneumatic control.....	33.224
<b>Hydraulic systems.....</b>	<b>35</b>
Hydraulic systems .....	35.000
Pump control valves .....	35.102
Variable displacement pump .....	35.106
Three-point hitch control valve .....	35.114
Remote control valves.....	35.204
Reservoir, cooler, and filters .....	35.300
Combination pump units.....	35.304
<b>Pneumatic system .....</b>	<b>36</b>
Pneumatic system.....	36.100
<b>Hitches, drawbars, and implement couplings.....</b>	<b>37</b>
Rear three-point hitch .....	37.110
Front hitch .....	37.162
<b>Steering.....</b>	<b>41</b>
Steering control.....	41.101

Hydraulic control components .....	41.200
Pump .....	41.206
<b>Cab climate control .....</b>	<b>50</b>
Heating .....	50.100
Air conditioning .....	50.200
Cab pressurizing system .....	50.300
<b>Electrical systems .....</b>	<b>55</b>
Engine cooling system .....	55.012
Front axle control system.....	55.045
Rear axle control system .....	55.046
Heating, Ventilation, and Air-Conditioning (HVAC) control system.....	55.050
Cab Heating, Ventilation, and Air-Conditioning (HVAC) controls.....	55.051
Harnesses and connectors .....	55.100
Three-point rear hitch electronic control system .....	55.130
Engine starting system .....	55.201
Alternator .....	55.301
Battery .....	55.302
External lighting .....	55.404
External lighting switches and relays.....	55.405
Warning indicators, alarms, and instruments.....	55.408
Cab controls .....	55.512
Cab lighting .....	55.514
Wiper/Washer system .....	55.518
Electronic modules .....	55.640
Selective Catalytic Reduction (SCR) electrical system.....	55.988
FAULT CODES .....	55.DTC
<b>Platform, cab, bodywork, and decals .....</b>	<b>90</b>
Engine hood and panels.....	90.100
Engine shields, hood latches, and trims.....	90.102

Protections and footboards .....	90.118
Pneumatically-adjusted operator seat .....	90.124
Cab .....	90.150
Cab interior .....	90.151



# INTRODUCTION

## Safety rules

Magnum 235 WE, Magnum 260 WE, Magnum 290 WE, Magnum 315 WE, Magnum 340 WE

### Personal safety





This is the safety alert symbol. It is used to alert you to potential personal injury hazards. Obey all safety messages that follow this symbol to avoid possible death or injury.

Throughout this manual and on machine decals, you will find the signal words DANGER, WARNING, and CAUTION followed by special instructions. These precautions are intended for the personal safety of you and those working with you.

Read and understand all the safety messages in this manual before you operate or service the machine.

 DANGER indicates a hazardous situation which, if not avoided, will result in death or serious injury. The color associated with DANGER is RED.

 WARNING indicates a hazardous situation which, if not avoided, could result in death or serious injury. The color associated with WARNING is ORANGE.

 CAUTION, used with the safety alert symbol, indicates a hazardous situation which, if not avoided, could result in minor or moderate injury. The color associated with CAUTION is YELLOW.

**FAILURE TO FOLLOW DANGER, WARNING, AND CAUTION MESSAGES COULD RESULT IN DEATH OR SERIOUS INJURY.**

### Machine safety

**NOTICE:** Notice indicates a situation which, if not avoided, could result in machine or property damage. The color associated with Notice is BLUE.

Throughout this manual you will find the signal word Notice followed by special instructions to prevent machine or property damage. The word Notice is used to address practices not related to personal safety.

### Information

**NOTE:** Note indicates additional information which clarifies steps, procedures, or other information in this manual.

Throughout this manual you will find the word Note followed by additional information about a step, procedure, or other information in the manual. The word Note is not intended to address personal safety or property damage.

## Safety rules

Magnum 235, Magnum 260, Magnum 290, Magnum 315, Magnum 340

### Standard safety precautions

Be informed and notify personnel of the laws in force regulating safety, and provide documentation available for consultation.

- Keep working areas as clean as possible.
- Ensure that working areas are provided with emergency boxes. They must be clearly visible and always contain adequate sanitary equipment.
- Fire extinguishers must be properly identified and always be clear of obstructions. Their efficiency must be checked on a regular basis and personnel must be trained on proper interventions and priorities.
- Keep all emergency exits free of obstructions and clearly marked.
- Smoking in working areas subject to fire danger must be strictly prohibited.

### Prevention of injury

- Wear suitable work attire and safety glasses with no jewelry such as rings and chains when working close to engines and equipment in motion.
- Wear safety gloves and goggles when performing the following operations:
  - Topping off or changing lubrication oils.
  - Using compressed air or liquids at a pressure greater than **2 bar (29 psi)**.
- Wear a safety helmet when working close to hanging loads or equipment working at head level.
- Always wear safety shoes and fitting clothes.
- Use protection cream for hands.
- Change wet clothes as soon as possible.
- In the presence of voltages exceeding **48 - 60 V**, verify the efficiency of the ground and mass electrical connections. Ensure that hands and feet are dry and use isolating foot boards. Workers should be properly trained to work with electricity.
- Do not smoke or start an open flame close to batteries and any fuel material.
- Place soiled rags with oil, diesel fuel or solvents in specially provided anti-fire containers.
- Do not use any tool or equipment for any use other than what it was originally intended for. Serious injury may occur.
- If running an engine indoors, make sure there is a sufficient exhaust fan in use to eliminate exhaust fumes.

### During maintenance

- Never open the filler cap of the cooling system when the engine is hot. High temperature liquid at operating pressure could result in serious danger and risk of burn. Wait until the temperature decreases under **50 °C (122 °F)**.
- Never add coolant to an overheated engine and use only appropriate liquids.
- Always work when the engine is turned off. Certain circumstances require maintenance on a running engine. Be aware of all the risks involved with such an operation.
- Always use adequate and safe containers for engine fluids and used oil.
- Keep engine clean of any spilled fluids such as oil, diesel fuel, and or chemical solvents.
- Use of solvents or detergents during maintenance may emit toxic vapors. Always keep working areas aerated. Wear a safety mask if necessary.
- Do not leave soiled rags that may contain any flammable substances close to the engine.
- Always use caution when starting an engine after any work has been performed. Be prepared to cut off intake air in case of engine runaway.

- Never disconnect the batteries while the engine is running.
- Disconnect the batteries prior to performing any work on the equipment.
- Disconnect the batteries to place a load on them with a load tester.
- After any work is performed, verify that the battery clamp polarity is correct and that the clamps are tight and safe from accidental short circuit and oxidation.
- Before disconnecting any pipelines (pneumatic, hydraulic, fuel pipes, etc.), verify that all pressure has been released. Take all necessary precautions bleeding and draining residual pressure. Always wear the proper safety equipment.
- Do not alter the lengths of any wires.
- Do not connect any electronic service tool to the engine electrical equipment unless specifically approved by Iveco.
- Do not modify the fuel system or hydraulic system unless approved by Iveco, Any unauthorized modification will compromise warranty assistance and may affect engine operation and life span.

For engine equipped with an electronic control unit

- Do not weld on any part of the equipment without removing the control unit.
- Remove the in case of work requiring heating over **80 °C (176 °F)**.
- Do not paint the components and the electronic connections.
- Do not alter any data filed in the electronic control unit driving the engine. Any manipulation or alteration of electronic components will void engine warranty assistance and may affect the correct working order and life span of the engine.

### **Respect of the Environment**

- Respect of the environment should be of primary importance. Take all necessary precautions to ensure personnel's safety and health.
- Inform the personnel of the laws regarding the dispensing of used engine fluids.
- Handle batteries with care, storing them in a well ventilated environment and within anti-acid container.

## SERVICE MANUAL

### Engine

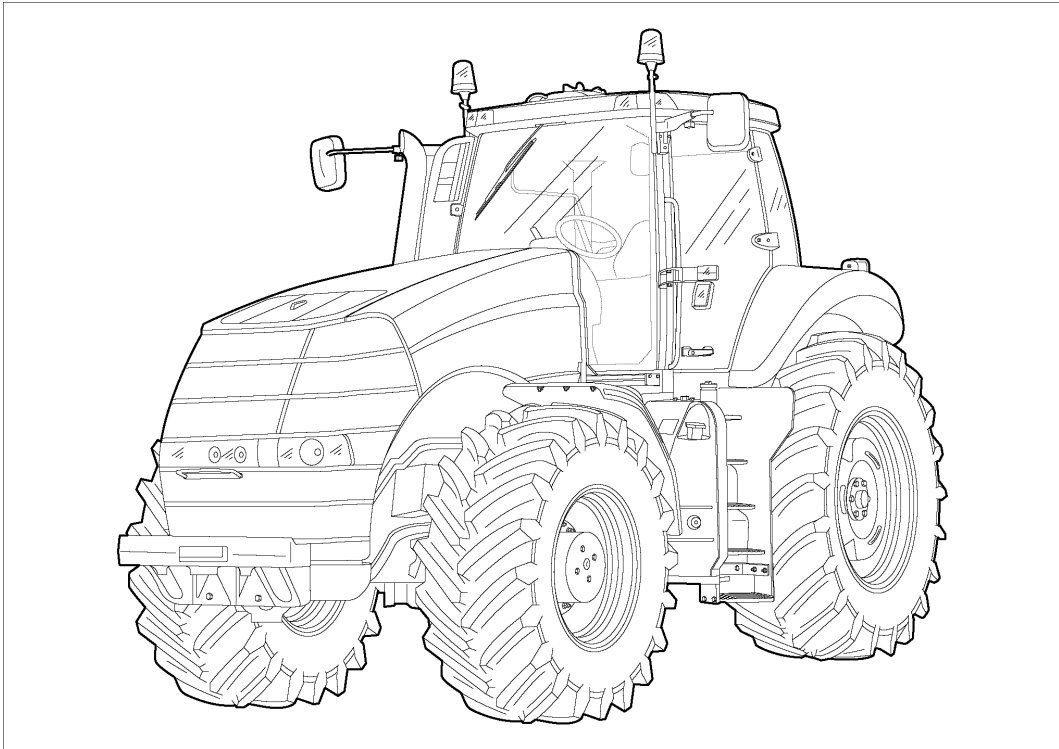

**Magnum 235 WE**  
**Magnum 260 WE**  
**Magnum 290 WE**  
**Magnum 315 WE**  
**Magnum 340 WE**

## Engine - Remove

Magnum 235, Magnum 260, Magnum 290, Magnum 315, Magnum 340

**Prior operation:**

**Battery - Disconnect (55.302)**

**Prior operation:**

**Side shield - Remove (90.102)**

**Prior operation:**

**Hood - Remove (90.100)**

**Prior operation:**

**Engine cooling system - Emptying (10.400)**

**Prior operation:**

**Air conditioning - Recover (50.200)**

**NOTE:** During the disassembly of components with O-ring seals, the seals should be discarded and new seal installed during assembly.

**NOTE:** Cap all fittings and plug all lines/hoses as they are disconnected.

1. Disconnect the hydraulic cooling line connection on the right side (from oil cooler).

**NOTE:** Be prepared to collect some hydraulic oil by placing a pan under the fitting.

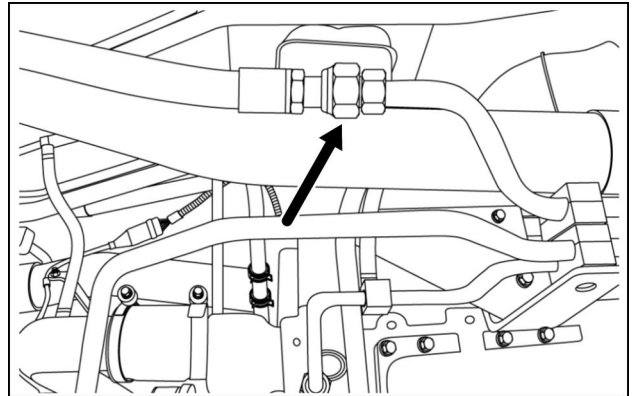

RCPH10CCH771AAB 1

2. Disconnect the hydraulic line (1) on the left side (to oil cooler). Disconnect the engine cooling fan drive harness connector (3).
3. Disconnect the air conditioning low pressure hose to line fitting (return from condenser) (2).
4. Remove the bolt securing the harness P-clamp (4).

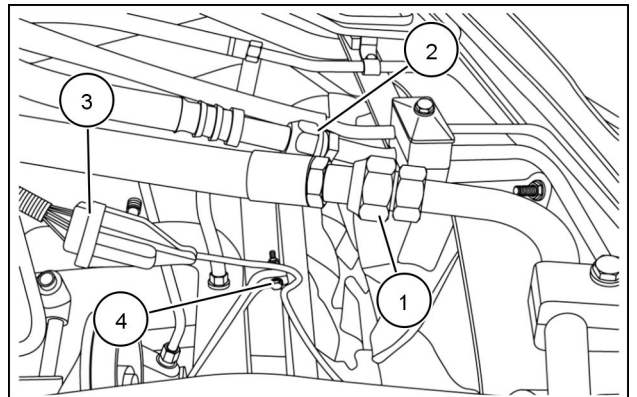

RCPH10CCH772AAB 2

5. Disconnect the air conditioning high pressure hose to tube fitting (1).
6. Disengage the hose clamps (2), and disconnect the cooler hoses (3) (4).

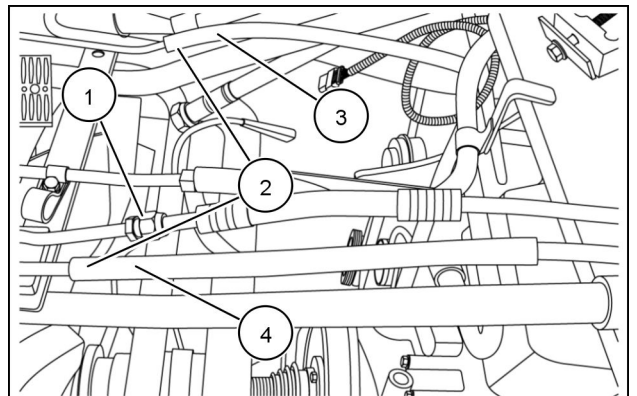

RCPH10CCH773AAB 3

7. Disengage the hose clamps **(1)** and disconnect the air vent hose **(2)** and the hose **(3)** from the deaeration tank to the recovery bottle.

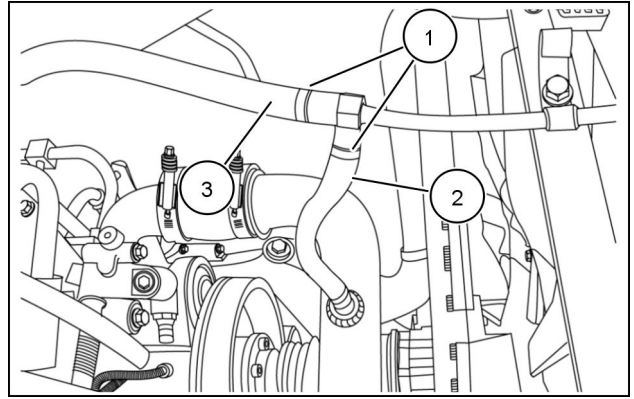

RCPH10CCH774AAB 4

8. Loosen the turbocharger clamp **(1)**.  
9. Loosen the air cooler inlet hose clamp **(2)**.  
10. Remove the pipe **(3)** and set aside.  
11. Repeat for the right side air to air tube from the cooler to the intake manifold (not shown).

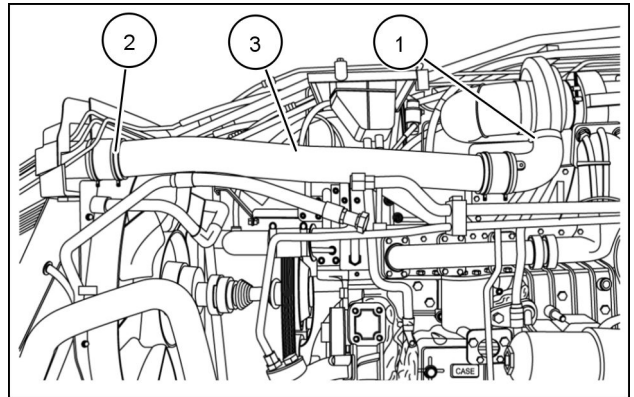

RCPH10CCH775AAB 5

12. Remove and discard the O-ring seal from the elbow.

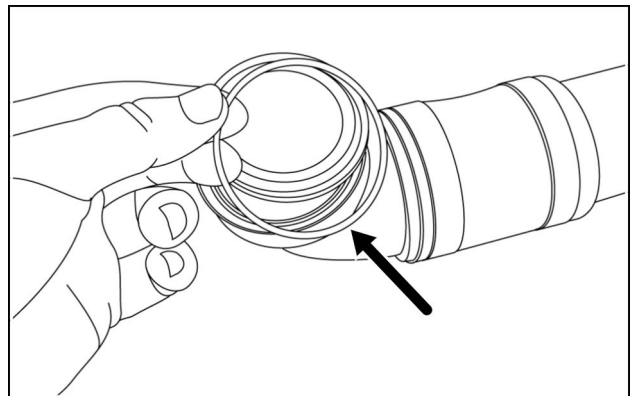

RCPH10CCH778AAB 6

13. Remove and discard the O-ring seal from the elbow.

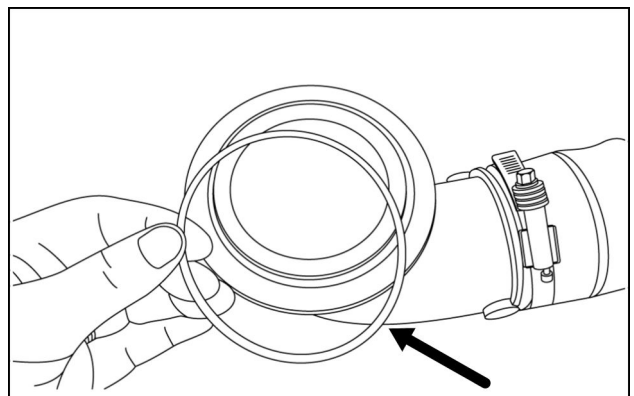

RCPH10CCH777AAB 7

14. Loosen the hose clamp **(1)** at the engine coolant outlet and disconnect the hose from the thermostat housing.

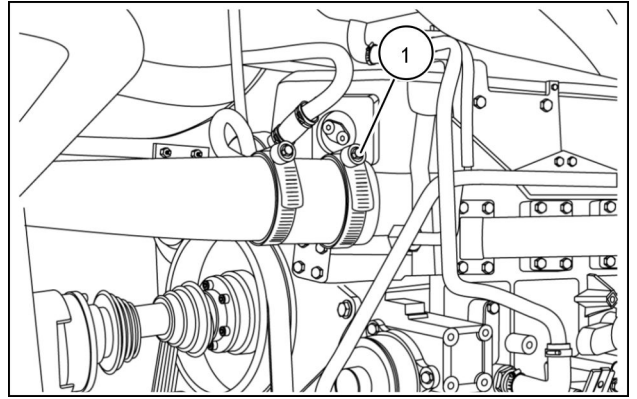

RCPH10CCH776AAB 8

15. Loosen the hose clamp and disconnect the coolant line into the engine hose.

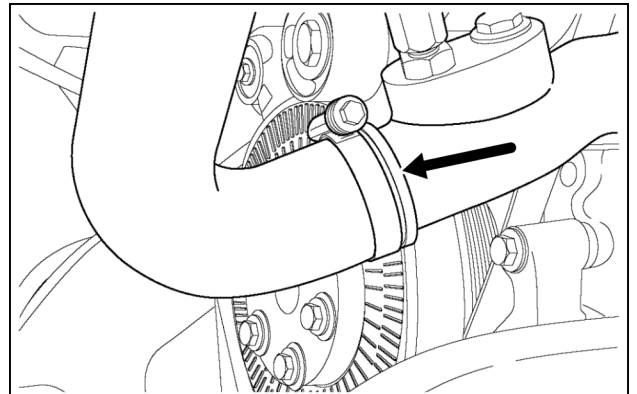

RCPH10CCH580AAB 9

16. Remove the nuts **(1)** and disengage the engine heater grid cables **(2)** **(3)** to the fuse block.  
 17. Disconnect the harness connector **(4)** for the **12 V** auxiliary power connection .

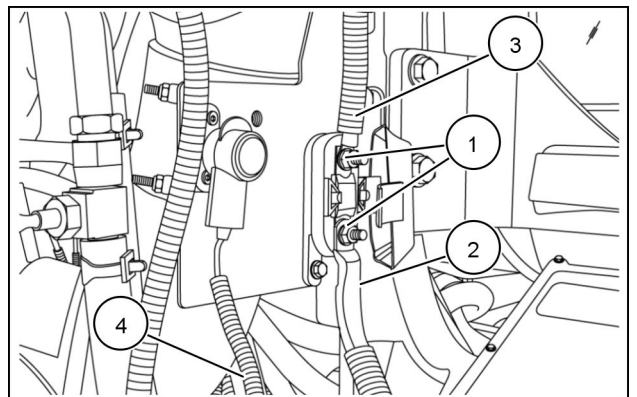

RCPH10CCH779AAB 10

18. Disconnect the ECM (engine control module) connector **(1)** by moving the locking handle **(2)** from the right (locked position) to the left (unlocked position).

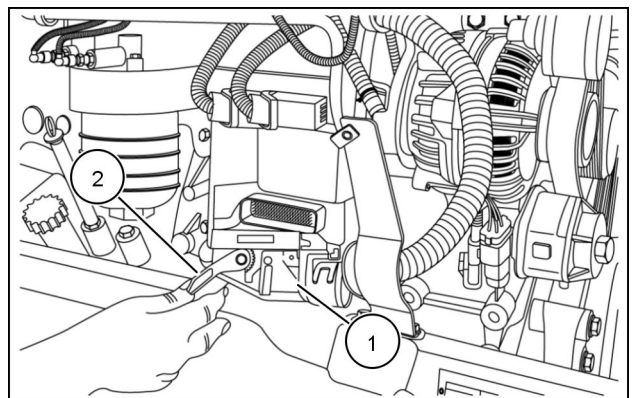

RCPH10CCH780AAB 11

19. Disconnect the tractor to engine harness connectors **(1)**.

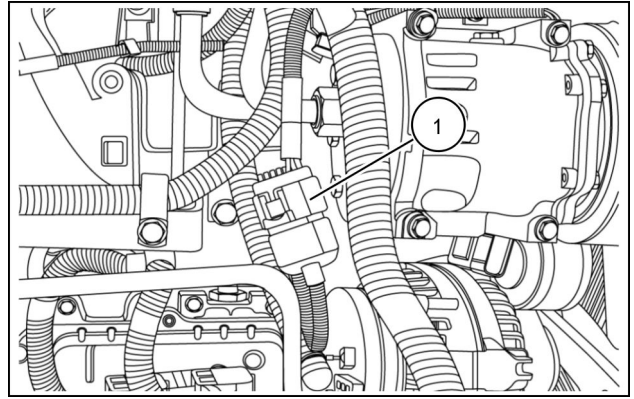

RCPH10CCH781AAB 12

20. Disconnect the harness connectors to the alternator **(1)** and the A/C compressor clutch **(2)**.
21. Remove the upper left A/C compressor bolt and remove the ground wire **(3)**.

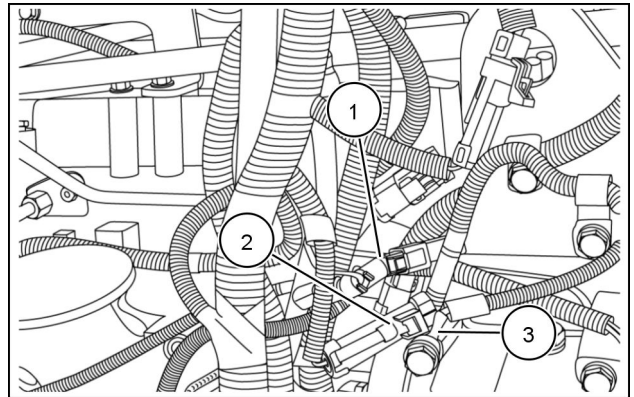

RCPH10CCH782AAB 13

22. Disconnect the harness connectors to the A/C high pressure switch **(1)** and the engine cooling fan drive **(2)**.

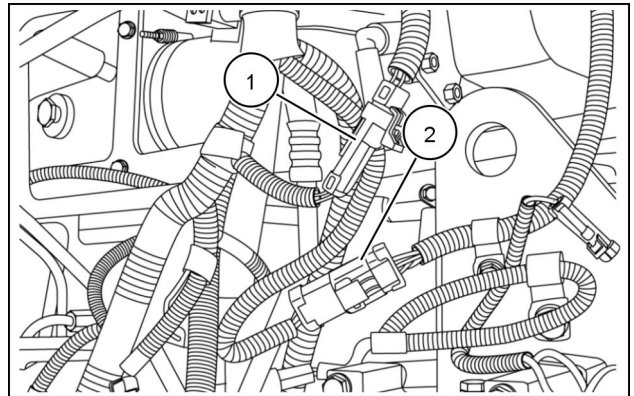

RCPH10CCH783AAB 14

23. Disconnect the harness connector **(1)** to the grid heater controller.

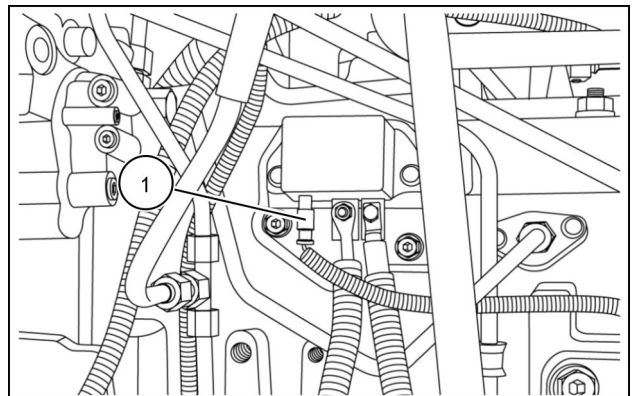

RCPH10CCH784AAB 15

24. Remove the nut **(1)** and the clamp bolts **(2)**. Disengage the power cable **(3)**.

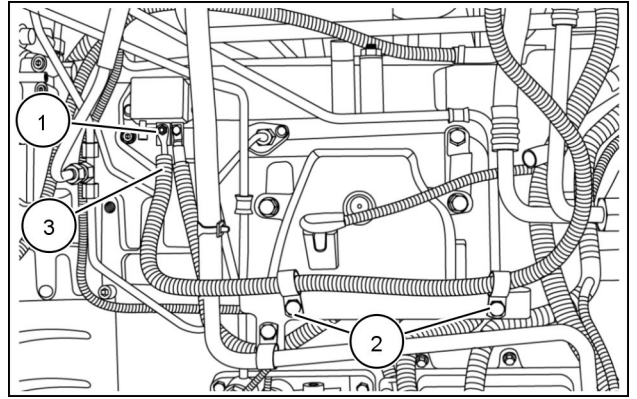

RCPH10CCH785AAB 16

25. Loosen the nut **(1)** and disconnect the fuel supply line to the EMC cooler

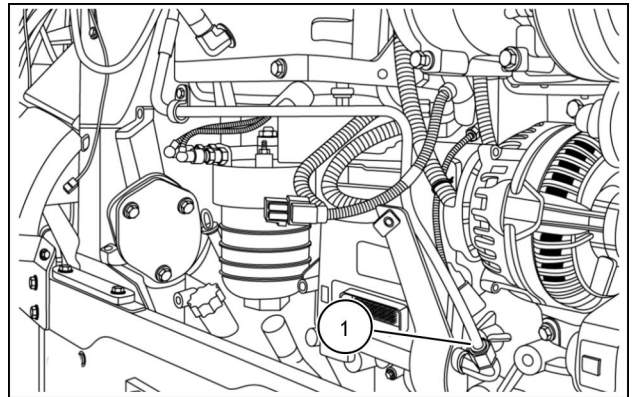

RCPH10CCH787AAB 17

26. Disengage the clamp **(1)** and disconnect the fuel return hose **(2)** from the pipe.

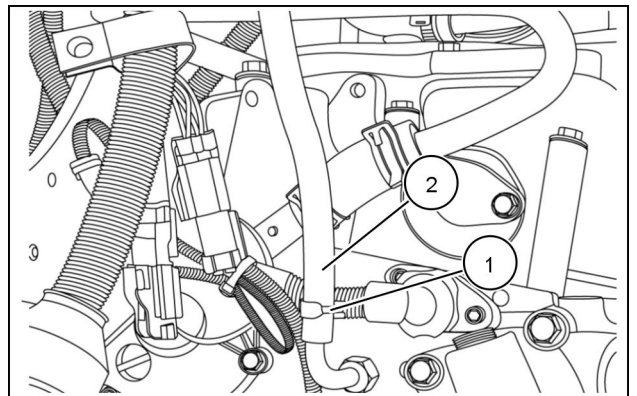

RCPH10CCH786AAB 18

27. Remove the nut **(1)** and disengage the alternator output cable **(2)**.

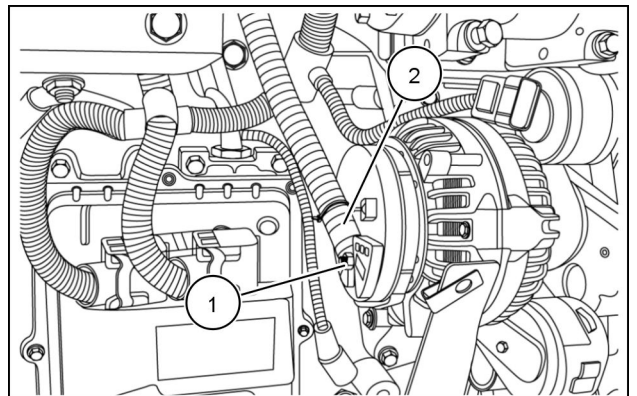

RCPH10CCH788AAB 19

28. Loosen the nuts **(1)** and disconnect the compressor inlet **(2)** and outlet **(3)** tubes.

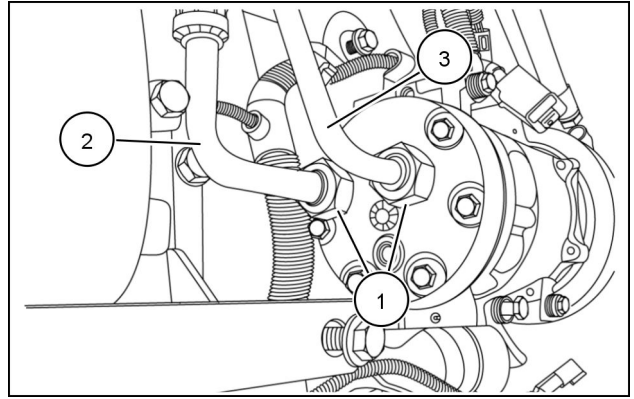

RCPH10CCH789AAB 20

29. Disconnect the harness connector to the SCR heater control valve solenoid **(1)**.
30. Raise the locking wire **(2)** and disconnect the heater supply connector **(3)** from the valve.
31. Repeat for the outlet hose connection (located on the right side of the valve).

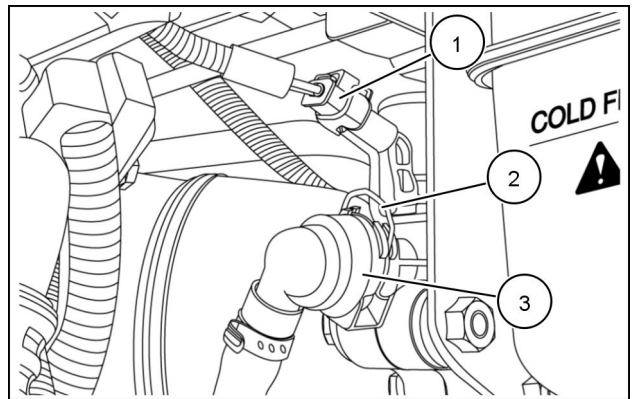

RCPH10CCH790AAB 21

32. Disconnect the main engine to chassis harness connector.

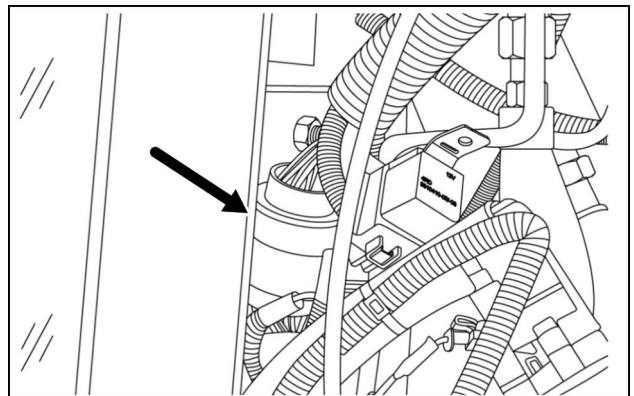

RCPH10CCH791AAB 22

33. Disconnect the auxiliary engine to chassis harness connectors **(1)**.

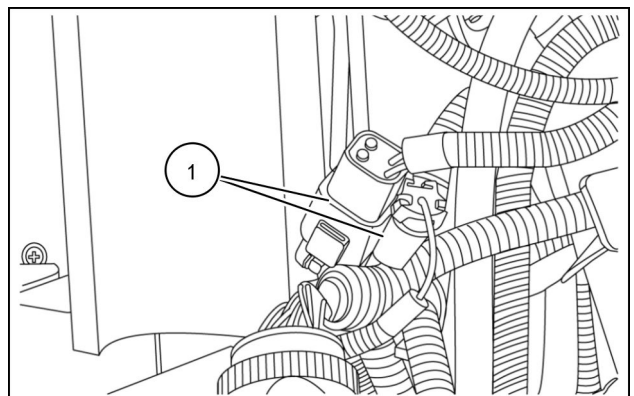

RCPH10CCH792AAB 23

34. Remove the holding nut (1) and disengage the ground wire (2).

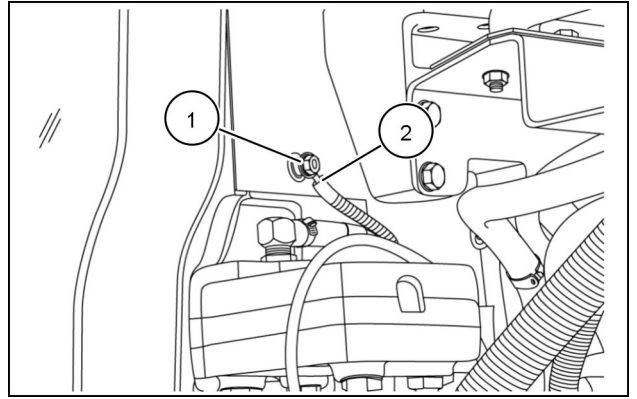

RCPH10CCH793AAB 24

35. Loosen the fitting and disconnect the hydraulic oil line (1) (right side of engine).

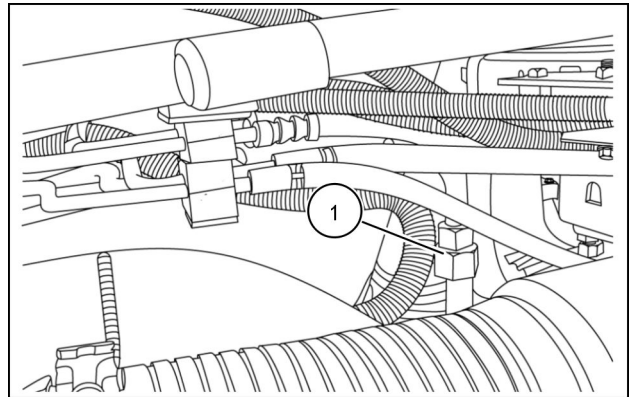

RCPH10CCH798AAB 25

36. Disconnect the water in fuel sensor connector (1) from the primary fuel filter.

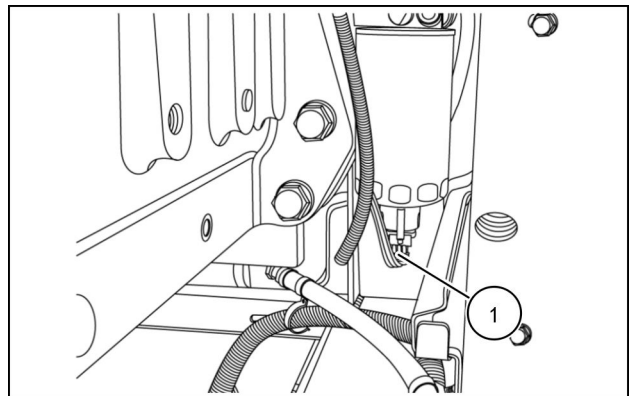

RCPH10CCH794AAB 26

37. Loosen the nuts (1) and disconnect the A/C lines located between the hood support and the cab.

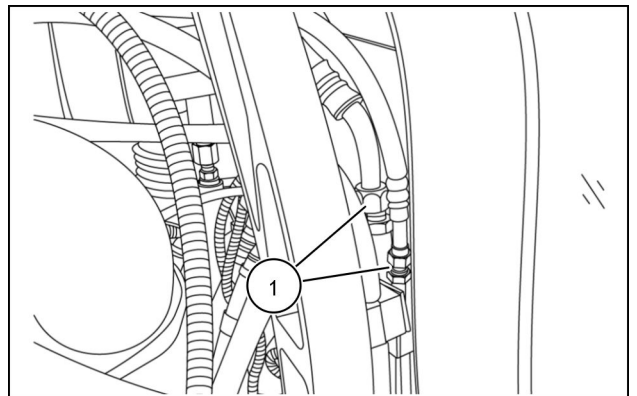

RCPH10CCH799AAB 27

38. Remove the jump start stud.

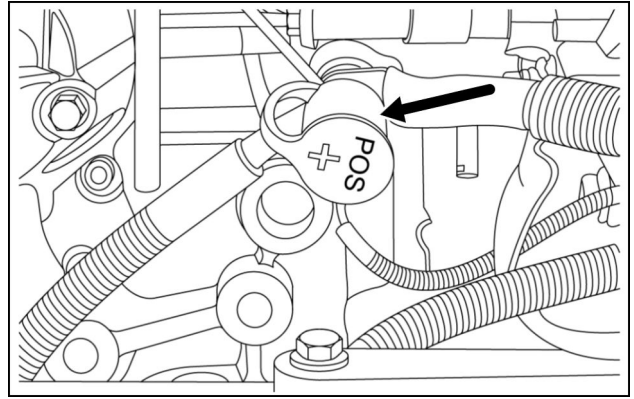

RCPH10CCH796AAB 28

39. Remove the nut (1) and disengage the cables from the starter.

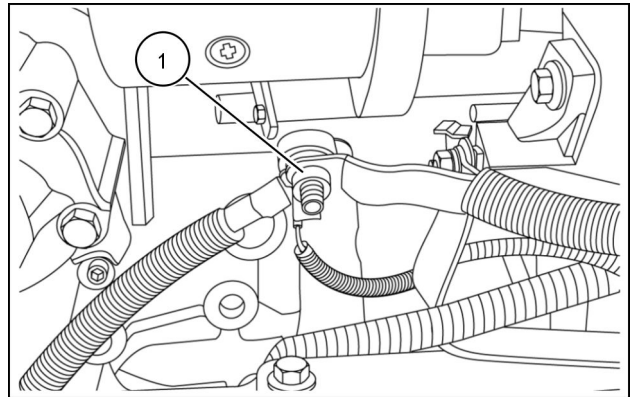

RCPH10CCH797AAB 29

40. Remove the plug (1), remove the attaching screw (2) and remove the starter solenoid wire (3).

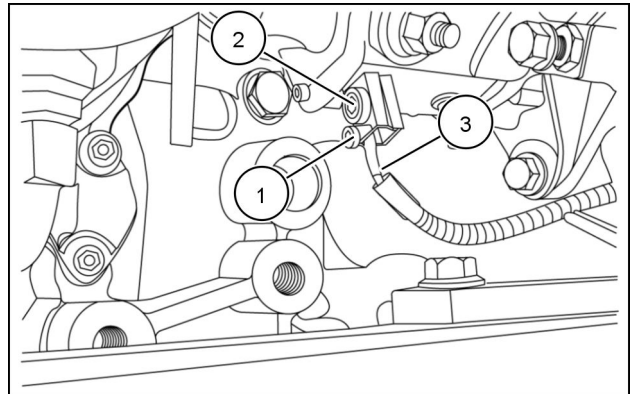

RCPH10CCH818AAB 30

41. Loosen the hose clamp (1) and disconnect the fill hose elbow (2).

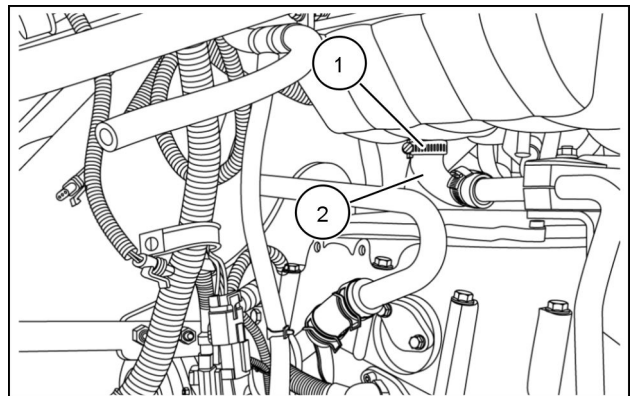

RCPH10CCH795AAB 31

42. Remove the six socket head bolts **(1)** and three backing plates **(2)** securing the drive shaft assembly to the engine drive pulley. Disengage the drive from the pulley.

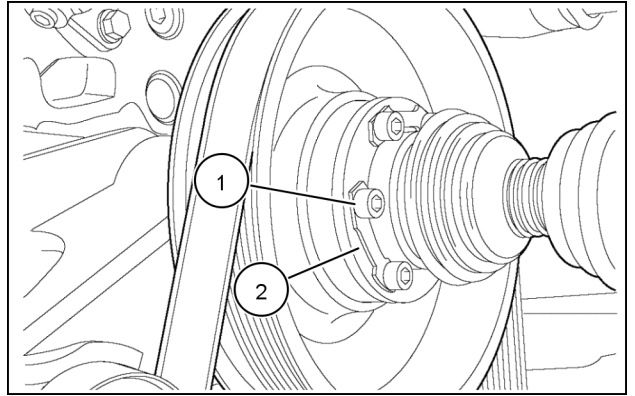

RCPH10CCH562AAB 32

43. Remove the nuts and washers **(1)** from the cooling assembly support bracket on the left and right sides.

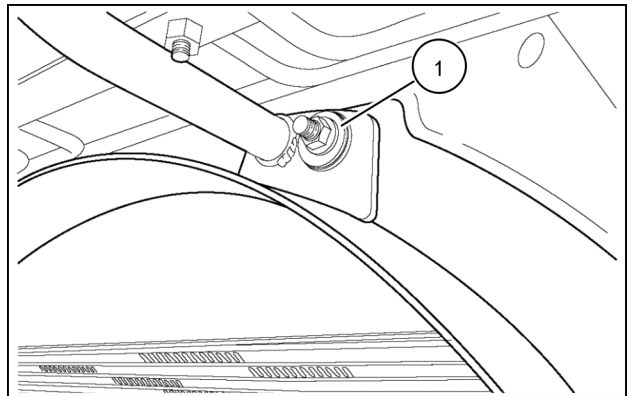

RCPH10CCH572AAB 33

44. Properly support the bracket, and remove the four bolts **(1)** securing the bracket to the hood support. Remove the assembly and set aside.

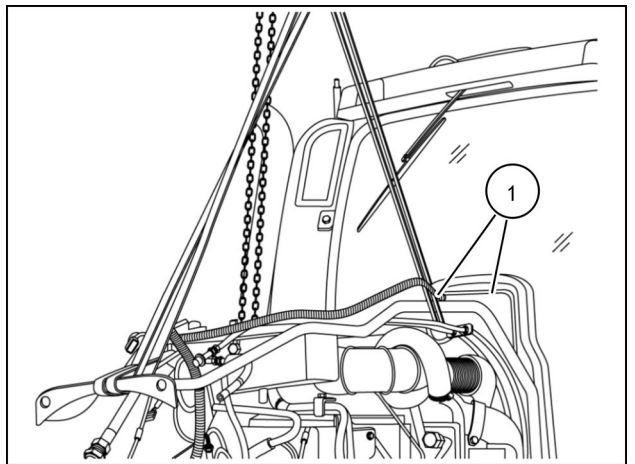

RCPH10CCH037BAB 34

45. Loosen the clamp **(1)** and disconnect the coolant fill line.
46. Loosen the nuts **(2)** and **(3)** and disconnect the cab heater supply and return lines.
47. Disengage the clamp **(4)** and remove the air bleed hose.
48. Remove the three bolts **(5)** securing the front support bracket.

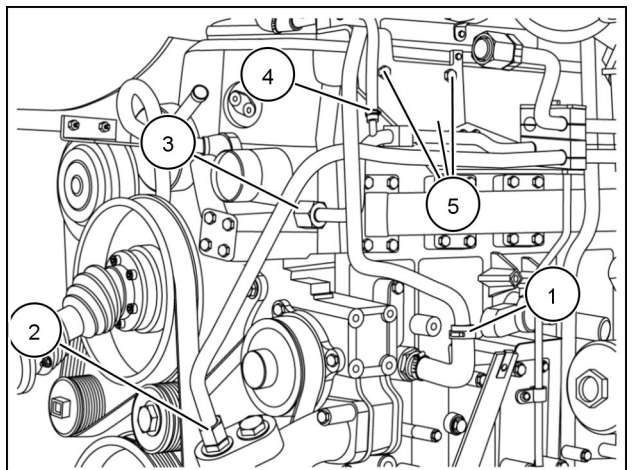

RCPH10CCH038BAB 35

49. Remove the two bolts (1) securing the rear support bracket.

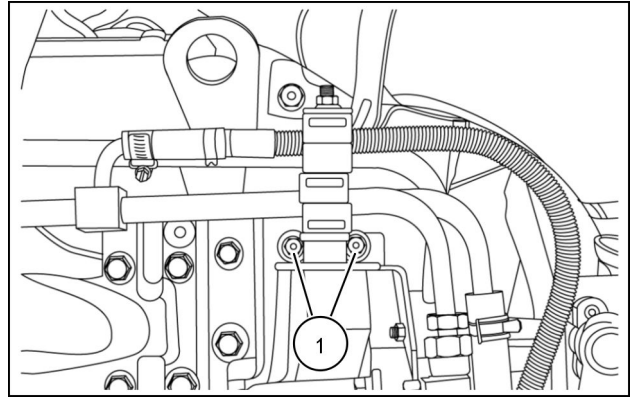

RCPH10CCH800AAB 36

50. Disconnect the harness connector (1) to the dosing valve.

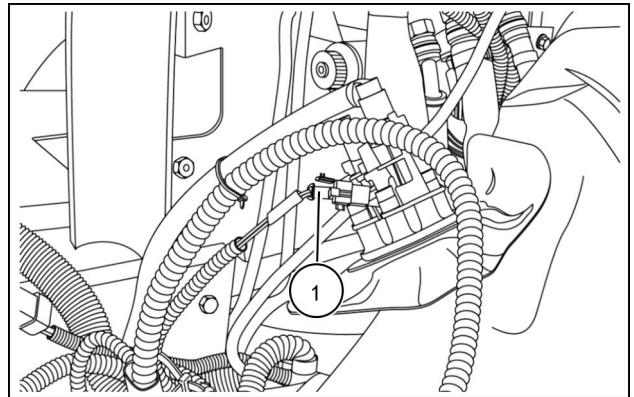

RCPH10CCH801AAB 37

51. Disconnect the DEF supply and return hoses (1).

**NOTE:** Squeeze the locking tabs (2) together and pull straight upward on the elbow.

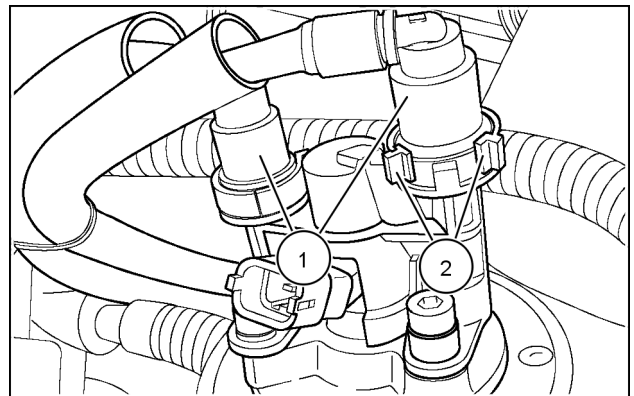

RCPH10CCH359AAB 38

52. Remove the clamp (1) at the turbocharger. Repeat for clamp at the other end of the pipe (2). Remove the pipe and set aside.

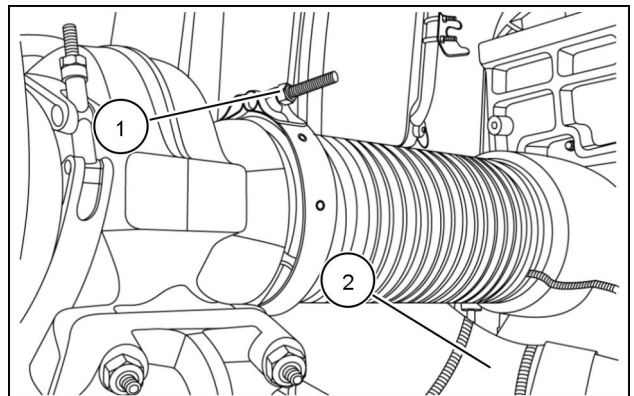

RCPH10CCH806AAB 39



**Suggest:**

**If the above button click is invalid.**

**Please download this document**

**first, and then click the above link**

**to download the complete manual.**

**Thank you so much for reading**

53. Remove the clamp **(1)** at the SCR muffler. Remove the attaching bolt **(2)** securing the support bracket. Remove the pipe and set aside.

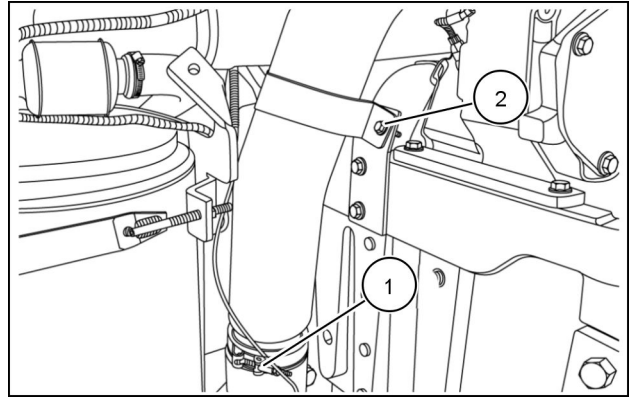

RCPH10CCH803AAB 40

54. Disengage the engine blow-by hose clamp **(1)** at the intake pipe. Disconnect from the intake pipe.

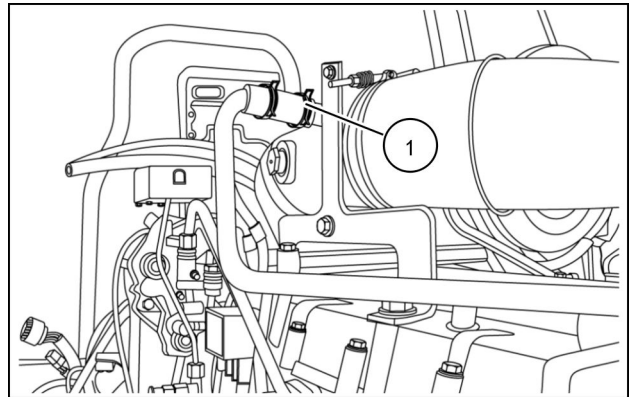

RCPH10CCH805AAB 41

55. Disengage the engine blow-by hose clamp **(1)** at the engine. Remove the pipe and set aside.

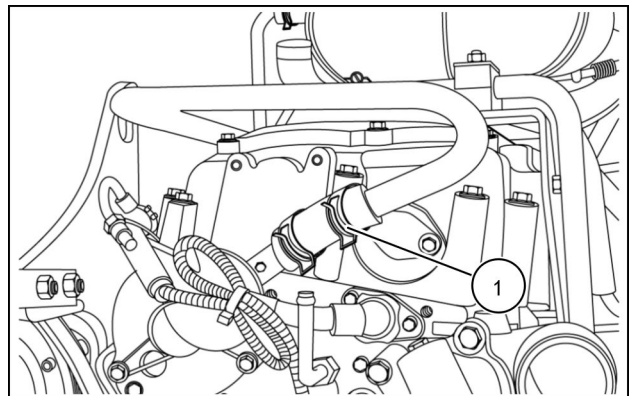

RCPH10CCH807AAB 42

56. Loosen the clamp **(1)** securing the intake pipe elbow to the turbocharger. Disconnect from the turbo.

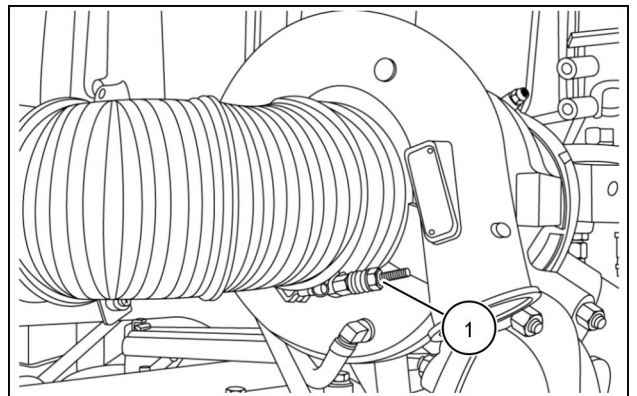

RCPH10CCH809AAB 43

**<https://www.ebooklibonline.com>**

Hello dear friend!

Thank you very much for reading.

Enter the link into your browser.

The full manual is available for immediate download.

**<https://www.ebooklibonline.com>**