

AXIAL-FLOW® 7230
AXIAL-FLOW® 8230
AXIAL-FLOW® 9230
Tier 4
Combine

SERVICE MANUAL

Part number 84564609

1st edition English

June 2012



Contents

INTRODUCTION

Engine.....	10
Engine and crankcase.....	10.001
Aftercooler.....	10.310
Engine cooling system	10.400
Fan and drive.....	10.414
Rotary screen.....	10.418
Engine air compressor	10.450
Selective Catalytic Reduction (SCR) exhaust treatment	10.500
Main gearbox and drive	14
Main gearbox and drive	14.100
Transmission.....	21
Mechanical transmission lubrication system	21.100
Mechanical transmission	21.114
Mechanical transmission external controls	21.130
Gearbox internal components	21.145
Differential	21.182
Front axle system	25
Powered front axle	25.100
Final drive hub, steering knuckles, and shafts	25.108
Final drives	25.310
Rear axle system.....	27
Powered rear axle	27.100
Final drive hub, steering knuckles, and shafts	27.124
Hydrostatic drive.....	29
Transmission and steering hydrostatic control	29.100
Two-speed assembly.....	29.134

Hydrostatic transmission	29.202
Pump and motor components	29.218
Rear hydrostatic transmission	29.300
Power Take-Off (PTO)	31
Front Power Take-Off (PTO).....	31.146
Brakes and controls	33
Parking brake / Parking lock.....	33.110
Hydraulic service brakes	33.202
Hydraulic systems.....	35
Hydraulic systems	35.000
Pump control valves	35.102
Variable displacement pump	35.106
Auxiliary hydraulic pump and lines	35.220
Reservoir, cooler, and filters	35.300
Safety and main relief valves.....	35.350
Main control valve	35.359
Header/Attachment height system	35.410
Header/Attachment tilting system	35.415
Grain tank unload system	35.440
Reel control system	35.518
Crop processor system.....	35.536
Chaff spreader control.....	35.796
Steering.....	41
Steering control.....	41.101
Hydraulic control components.....	41.200
Cylinders	41.216
Wheels.....	44
Front wheels.....	44.511

<https://www.ebooklibonline.com>

Hello dear friend!

Thank you very much for reading.

Enter the link into your browser.

The full manual is available for immediate download.

<https://www.ebooklibonline.com>

Rear wheels	44.520
Tracks and track suspension	48
Tracks	48.100
Track frame and driving wheels	48.130
Track tension units	48.134
Track rollers	48.138
Cab climate control	50
Heating	50.100
Ventilation	50.104
Air conditioning	50.200
Electrical systems	55
Electrical system	55.000
Fuel injection system	55.010
Fuel tank system	55.011
Engine cooling system	55.012
Engine oil system	55.013
Engine intake and exhaust system	55.014
Engine control system	55.015
Hydrostatic drive control system	55.019
Transmission pressure sensors	55.021
Transmission control system	55.024
Service brake electrical system	55.030
Parking brake electrical system	55.031
Hydraulic system control	55.036
Heating, Ventilation, and Air-Conditioning (HVAC) control system	55.050
Cab Heating, Ventilation, and Air-Conditioning (HVAC) controls	55.051
Harnesses and connectors	55.100
Engine starting system	55.201
Cold start aid	55.202

Alternator	55.301
Battery	55.302
External lighting	55.404
Harvest material flow control system	55.426
Cab controls	55.512
Wiper/Washer system	55.518
Cab harvesting controls	55.520
Ground speed control	55.610
Electronic modules	55.640
Shaker shoe leveling system control	55.780
Precision farming system.....	55.785
Rotary screen drive and cleaning	55.830
Rotary separator control.....	55.836
Selective Catalytic Reduction (SCR) electrical system.....	55.988
FAULT CODES	55.DTC
Attachments/Headers.....	58
Attachment/Header frame	58.130
Product feeding	60
Floating roll, feed chain, and drive	60.105
Feeder housing	60.110
Stone trapping system.....	60.112
Feeder drive system.....	60.150
Threshing	66
Threshing	66.000
Concave	66.105
Concave control system.....	66.110
Threshing mechanism drive system.....	66.260
Rotor.....	66.331
Separation	72

Discharge beater	72.220
Rotary separator.....	72.420
Residue handling.....	73
Straw chopper drive system.....	73.210
Straw chopper electromagnetic clutch support.....	73.215
Straw chopper	73.230
Cleaning.....	74
Cleaning	74.000
Self-leveling frame.....	74.100
Cleaning drive systems.....	74.101
Grain pan.....	74.110
Upper shaker shoe	74.114
Lower shaker shoe	74.118
Fan housing	74.130
Fan drive system	74.136
Tailings return system	74.140
Crop storage / Unloading.....	80
Clean grain elevator	80.101
Grain tank	80.150
Grain tank unload drive system	80.175
Grain tank unload.....	80.180
Platform, cab, bodywork, and decals.....	90
Machine shields and guards.....	90.105
Protections and footboards.....	90.118
Pneumatically-adjusted operator seat.....	90.124
Cab	90.150
Cab interior	90.151



INTRODUCTION

Safety rules and signal word definitions

AXIAL-FLOW 7230 NA, AXIAL-FLOW 8230 NA, AXIAL-FLOW 9230 NA

Personal safety



This is the safety alert symbol. It is used to alert you to potential personal injury hazards. Obey all safety messages that follow this symbol to avoid possible death or injury.

Throughout this manual and on machine decals, you will find the signal words Danger, Warning, and Caution followed by special instructions. These precautions are intended for the personal safety of you and those working with you.

Read and understand all the safety messages in this manual before you operate or service the machine.

DANGER

DANGER indicates a hazardous situation which, if not avoided, will result in death or serious injury. The color associated with Danger is RED.

M1169A

WARNING

WARNING indicates a hazardous situation which, if not avoided, could result in death or serious injury. The color associated with Warning is ORANGE.

M1170A

CAUTION

CAUTION, used with the safety alert symbol, indicates a hazardous situation which, if not avoided, could result in minor or moderate injury. The color associated with Caution is YELLOW.

M1171A

FAILURE TO FOLLOW DANGER, WARNING, AND CAUTION MESSAGES COULD RESULT IN DEATH OR SERIOUS INJURY.

Machine safety

NOTICE: Notice indicates a situation which, if not avoided, could result in machine or property damage. The color associated with Notice is BLUE.

Throughout this manual you will find the signal word Notice followed by special instructions to prevent machine or property damage. The word Notice is used to address practices not related to personal safety.

Information

NOTE: Note indicates additional information which clarifies steps, procedures, or other information in this manual.

Throughout this manual you will find the word Note followed by additional information about a step, procedure, or other information in the manual. The word Note is not intended to address personal safety or property damage.

Safety rules Ecology and the Environment

AXIAL-FLOW 7230 NA, AXIAL-FLOW 8230 NA, AXIAL-FLOW 9230 NA

Soil, air, and water are vital factors of agriculture and life in general. When legislation does not yet rule the treatment of some of the substances which are required by advanced technology, common sense should govern the use and disposal of products of a chemical and petrochemical nature.

NOTICE: *The following are recommendations which may be of assistance:*

- Become acquainted with and ensure that you understand the relative legislation applicable to your country.
- Where no legislation exists, obtain information from suppliers of oils, filters, batteries, fuels, antifreeze, cleaning agents, etc., with regard to their effect on man and nature and how to safely store, use and dispose of these substances.
- Agricultural consultants will, in many cases, be able to help you as well.

HELPFUL HINTS

- Avoid filling tanks using cans or inappropriate pressurized fuel delivery systems which may cause considerable spillage.
- In general, avoid skin contact with all fuels, oils, acids, solvents, etc. Most of them contain substances which may be harmful to your health.
- Modern oils contain additives. Do not burn contaminated fuels and or waste oils in ordinary heating systems.
- Avoid spillage when draining off used engine coolant mixtures, engine, gearbox and hydraulic oils, brake fluids, etc. Do not mix drained brake fluids or fuels with lubricants. Store them safely until they can be disposed of in a proper way to comply with local legislation and available resources.
- Modern coolant mixtures, i.e. antifreeze and other additives, should be replaced every two years. They should not be allowed to get into the soil but should be collected and disposed of properly.
- Do not open the air-conditioning system yourself. It contains gases which should not be released into the atmosphere. Your CASE IH AGRICULTURE dealer or air conditioning specialist has a special extractor for this purpose and will have to recharge the system properly.
- Repair any leaks or defects in the engine cooling or hydraulic system immediately.
- Do not increase the pressure in a pressurized circuit as this may lead to a component failure.
- Protect hoses during welding as penetrating weld splatter may burn a hole or weaken them, allowing the loss of oils, coolant, etc.

Safety rules - Personal safety

AXIAL-FLOW 7230 NA, AXIAL-FLOW 8230 NA, AXIAL-FLOW 9230 NA

Carefully study these precautions, and those included in the external attachment operators manual, and insist that they be followed by those working with and for you.

1. Thoroughly read and understand this manual and the attachment Operator's Manual before operating this or any other equipment.
2. Be sure all people and pets are clear of the machine before starting. Sound the horn, if equipped, three times before starting engine.
3. Only the operator should be on the machine when in operation. Never allow anyone to climb on to the machine while it is in motion. If the machine is equipped with an Instructors Seat, this must only be used for training purposes. Passengers must not be allowed to use the Instructors Seat.
4. Keep all shields in place. Never work around the machine or any of the attachments while wearing loose clothing that might catch on moving parts.
5. Observe the following precautions whenever lubricating the machine or making adjustments.
 - Disengage all clutching levers or switches.
 - Lower the attachment, if equipped, to the ground or raise the attachment completely and engage the cylinder safety locks. Completing these actions will prevent the attachment from lowering unexpectedly.
 - Engage the parking brake.
 - Shut off the engine and remove the key.
 - Wait for all machine movement to stop before leaving the operators platform.
6. Always keep the machine in gear while travelling downhill.
7. The machine should always be equipped with sufficient front or rear axle weight for safe operation.
8. Under some field conditions, more weight may be required at the front or rear axle for adequate stability. This is especially important when operating in hilly conditions or/when using heavy attachments.
9. Always lower the attachment, shut off the engine, set the parking brake, engage the transmission gears, remove the key and wait for all machine movement to stop before leaving the operators platform.
10. If the attachment or machine should become obstructed or plugged; set the parking brake, shut off the engine and remove the key, engage the transmission gears, wait for all machine or attachment motion to come to a stop, before leaving the operators platform to removing the obstruction or plug.
11. Never disconnect or make any adjustments to the hydraulic system unless the machine and/or the attachment is lowered to the ground or the safety lock(s) is in the engaged position.
12. Use of the flashing lights is highly recommended when operating on a public road.
13. When transporting on a road or highway, use accessory lights and devices for adequate warning to the operators of other vehicles. In this regard, check local government regulations. Various safety lights and devices are available from your CASE IH AGRICULTURE dealer.
14. Practice safety 365 days a year.
15. Keep all your equipment in safe operating condition.
16. Keep all guards and safety devices in place.
17. Always set the parking brake, shut off the engine and remove the key, engage the transmission gears, wait for all machine or attachment motion to come to a stop, before leaving the operators platform to service the machine and attachment.
18. Remember: A careful operator is the best insurance against an accident.
19. Extreme care should be taken in keeping hands and clothing away from moving parts.

Safety rules

AXIAL-FLOW 7230 NA, AXIAL-FLOW 8230 NA, AXIAL-FLOW 9230 NA

All repair and maintenance works listed in this manual must be carried out only by qualified dealership personnel, strictly complying with the instructions given; and using, whenever possible, the special tools.

Anyone who carries out the above operations without complying with the procedures shall be responsible for the subsequent damages.

The manufacturer and all the organizations of its distribution chain, including - without limitation - national, regional, or local dealers, reject any responsibility for damages due to the anomalous behavior of parts and/or components not approved by the manufacturer himself, including those used for the servicing or repair of the product manufactured or marketed by the manufacturer. In any case, no warranty is given or attributed on the product manufactured or marketed by the manufacturer in case of damages due to an anomalous behavior of parts and/or components not approved by the manufacturer.

The information in this manual is up-to-date at the date of the publication. It is the policy of the manufacturer for continuous improvement. Some information could not be updated due to modifications of a technical or commercial type, as well as to suit the laws and regulations of different countries.

In case of questions, refer to your Sales and Service Networks.



SERVICE MANUAL

Engine



**AXIAL-FLOW 7230 NA
AXIAL-FLOW 8230 NA
AXIAL-FLOW 9230 NA**

Engine - Remove

AXIAL-FLOW 7230 NA

▲ WARNING

Avoid injury! Always do the following before lubricating, maintaining, or servicing the machine.

1. Disengage all drives.
 2. Engage parking brake.
 3. Lower all attachments to the ground, or raise and engage all safety locks.
 4. Shut off engine.
 5. Remove key from key switch.
 6. Switch off battery key, if installed.
 7. Wait for all machine movement to stop.
- Failure to comply could result in death or serious injury.

W0047A

▲ WARNING

Heavy objects!

Lift and handle all heavy components using lifting equipment with adequate capacity. Always support units or parts with suitable slings or hooks. Make sure the work area is clear of all bystanders.

Failure to comply could result in death or serious injury.

W0398A

Prior operation:

Engine hood - Remove (90.105) Engine cooling system - Drain fluid (10.400) Engine lubrication system - Drain fluid (10.304) Deaeration tank - Remove (10.400) Intake and exhaust manifolds and muffler - Remove (10.254) Engine cooling system - Remove (10.400) Fan and drive - Remove (10.414) Radiator - Remove (10.400) Air-conditioning compressor - Remove (50.200) Fuel supply lines Low pressure - Remove (10.210) Central wire harness - Remove (55.100)

1. Attach a suitable chain to the front lift eye (1) at the front of the engine.

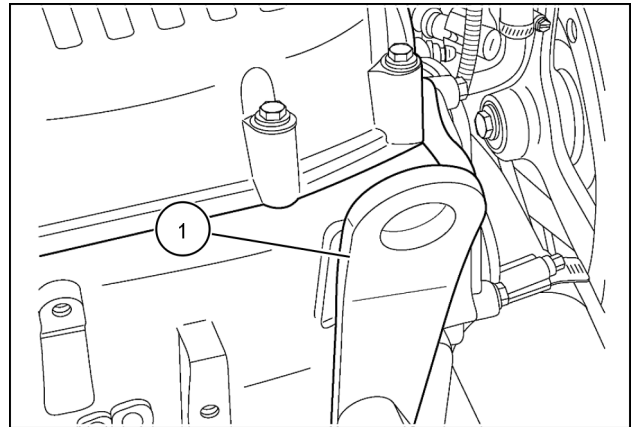

86070259 1

2. Attach a suitable chain to the back lift eye (1) at the rear of the engine.

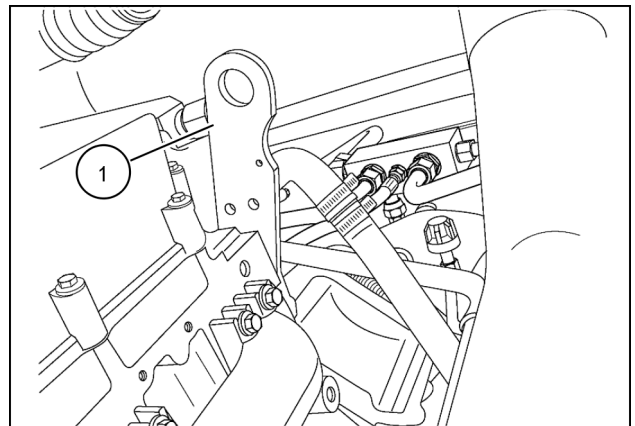

86070260 2

3. Connect the lift chain to a suitable lifting device.
4. Raise the lifting device enough to support the engine during removal of the engine mounting bolts.

NOTE: Illustration is for reference only. It may not be the actual engine.

NOTE: The lifting device should be rated for at least **907.2 kg (2000 lb)**. Allow enough clearance to lift the engine from the combine, approximately **7.0 m (23 ft)** from the floor.

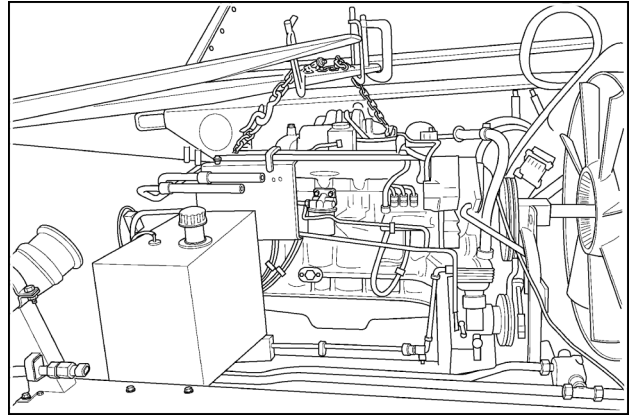

10013136 3

5. From inside the grain tank, loosen the front, engine mounting bolt (1). Do not remove the mounting bolts at this time.
6. From the platform side, loosen the front, engine mounting bolt (1). Do not remove the mounting bolts at this time.

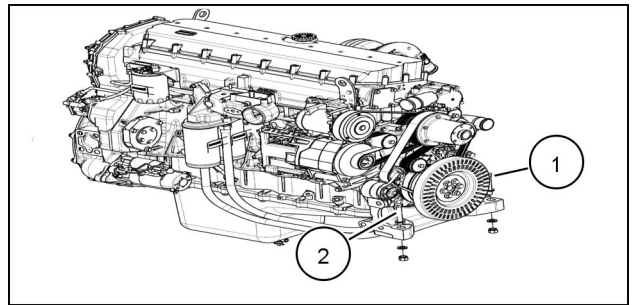

20086304 4

7. From the rear of the engine, loosen but do not remove all the bolts and washers (1) that couple the engine to the gearbox. There are twelve bolts and washers in total.
8. For safety reasons to the radiators, place a sheet of plywood, cut to size, in front of the cooler box for protection.
9. With the engine securely supported by the lifting device, remove all of the engine mounting bolts and the engine to the gearbox coupling bolts that were loosened in the previous steps.
10. Slide the engine towards the cooler box to disengage the flex plate from the gearbox input shaft.
11. Carefully lift the engine from the frame and remove from the combine.

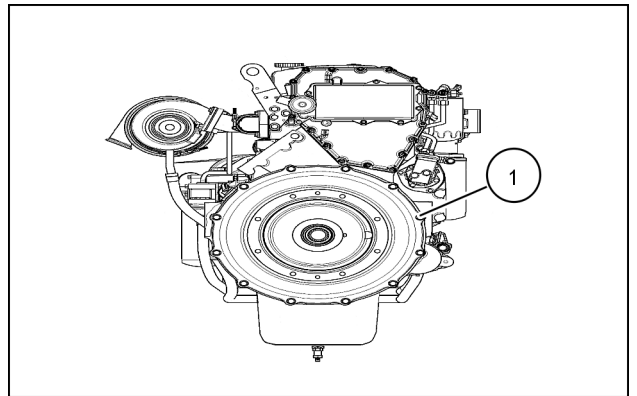

20107340 5

Next operation:
Engine - Install (10.001).

Engine - Install

AXIAL-FLOW 7230 NA

⚠ WARNING

Avoid injury! Always do the following before lubricating, maintaining, or servicing the machine.

1. Disengage all drives.
 2. Engage parking brake.
 3. Lower all attachments to the ground, or raise and engage all safety locks.
 4. Shut off engine.
 5. Remove key from key switch.
 6. Switch off battery key, if installed.
 7. Wait for all machine movement to stop.
- Failure to comply could result in death or serious injury.

W0047A

⚠ WARNING

Heavy objects!

Lift and handle all heavy components using lifting equipment with adequate capacity. Always support units or parts with suitable slings or hooks. Make sure the work area is clear of all bystanders. Failure to comply could result in death or serious injury.

W0398A

Prior operation:

Engine - Remove (10.001)

1. Before installing the engine, apply **LOCTITE® 767 ANTI-SEIZE** to the input shaft **(1)** of the gearbox.

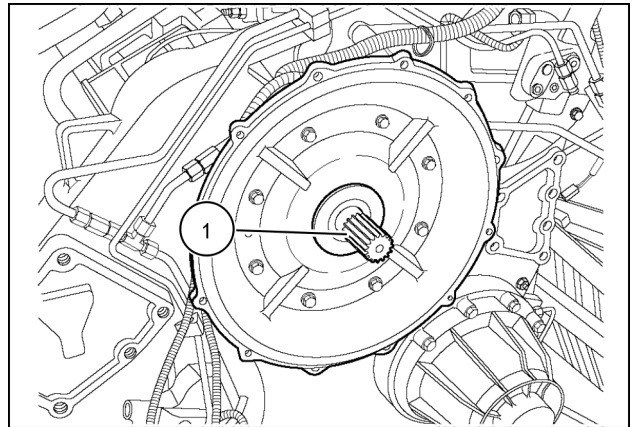

83070284 1

2. Attach a suitable chain to the front lift eye **(1)** at the front of the engine.

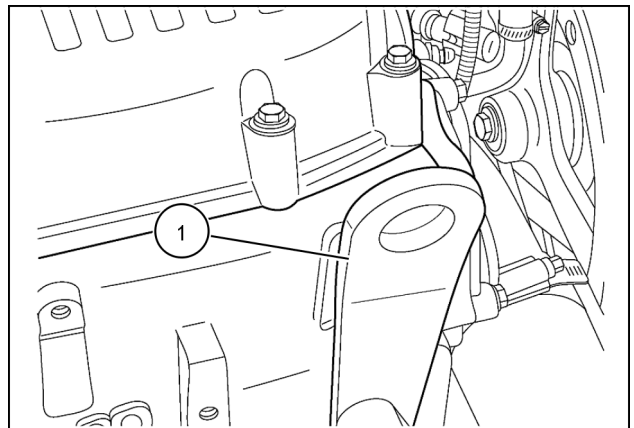

86070259 2

3. Attach a suitable chain to the back lift eye **(1)** at the rear of the engine.

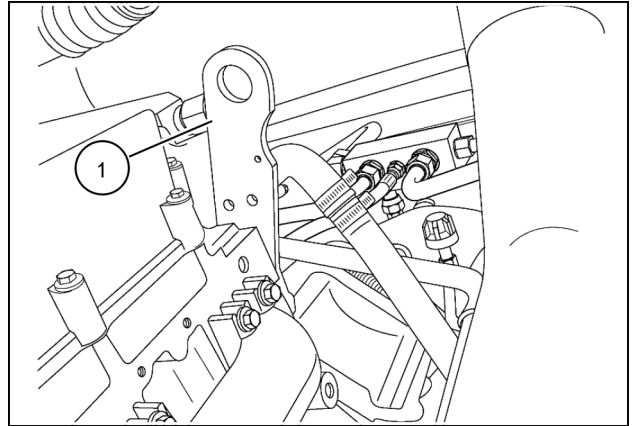

86070260 3

4. Connect the lift chain to a suitable lifting device.
5. Carefully lift the engine above the combine and lower into position in the frame.

NOTE: Illustration is for reference only. It may not be the actual engine.

NOTE: The lifting device should be rated for at least **907.2 kg (2000 lb)**. Allow enough clearance to lift the engine from the combine, approximately **907.2 kg (2000 lb)** from the floor.

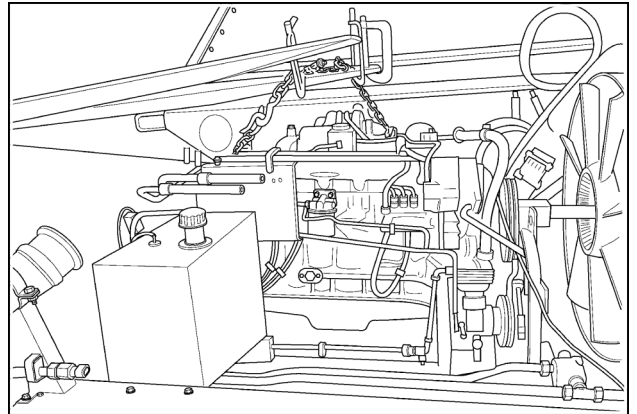

10013136 4

6. For safety reasons to the radiator, place a sheet of plywood, cut to size, in front of the radiator for protection.
7. Slide the engine towards the gearbox onto the gear box input shaft.
8. Align the holes of the gearbox with the engine and hand start a bolt with a washer **(1)** on each side of the coupling, going back and forth until all bolts with a washers are installed.

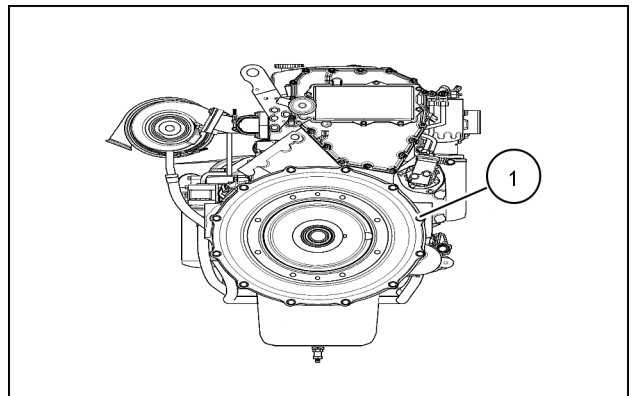

20107340 5

9. With the engine positioned in the frame, align the front mounting hole on the grain tank side and install the bolt with washers **(1)** into the mount. Do not tighten yet.

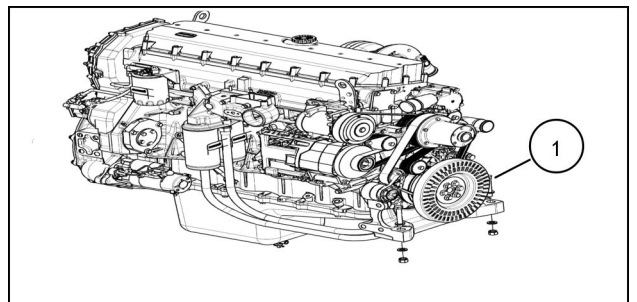

20086304 6

10. Align the front mounting hole on the platform side. Install the bolt with washers **(1)** into the mount.
11. Tighten and torque the front engine mounting bolts to **217 Nm (160.1 lb ft)**.
12. Tighten and torque the engine gearbox bolts to **41 - 51 Nm (30.2 - 37.6 lb ft)**.

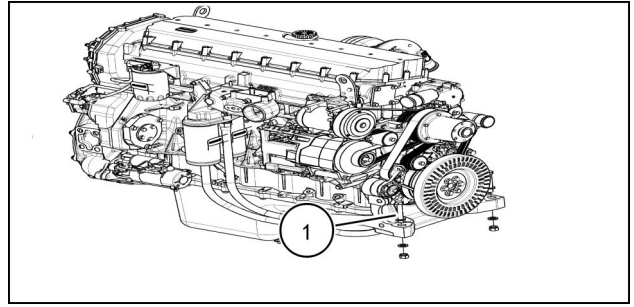

20086304 7

13. **Central wire harness - Install (55.100) Fuel supply lines Low pressure - Install (10.210) Air-conditioning compressor - Install (50.200) Fan and drive - Install (10.414) Radiator - Install (10.400) Engine cooling system - Install (10.400) Intake and exhaust manifolds and muffler - Install (10.254) Deaeration tank - Install (10.400) Engine lubrication system - Filling (10.304) Engine cooling system - Filling (10.400)**
14. Connect the battery cables to the batteries **(1)**.

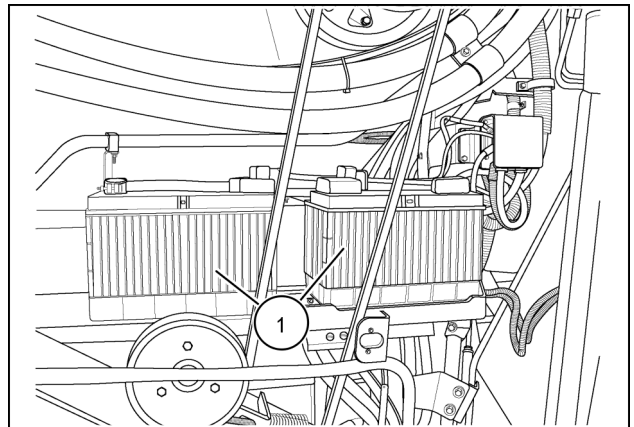

86063134 8

15. Disconnect the fuel pump wire connector **(1)** to disable the fuel pump **(2)**.
16. Check the engine oil level and top off if necessary.
17. Crank the engine over for three ten second intervals. This will distribute lubricating oil to the engine operating systems and will allow oil pressure to be built before starting the engine.

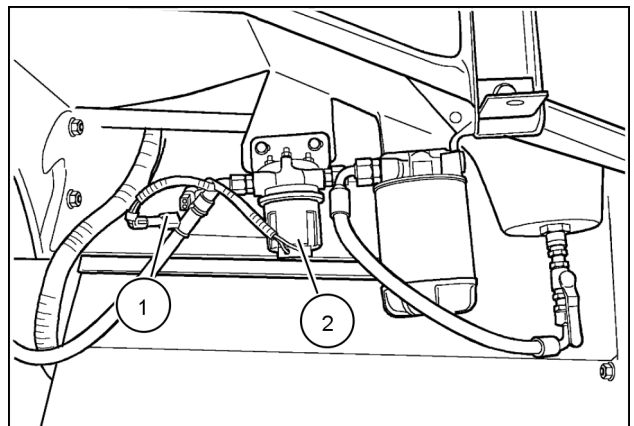

50030135 9

18. Connect the fuel pump wire connector **(1)** and bleed the air from fuel injection system, as described in the Operators manual.
19. Start the engine and check all hoses, fittings and clamps for leaks.

NOTICE: Monitor the instrument warning light bar at all times during initial engine start up to ensure the engine has proper oil pressure. Shut down the engine immediately if oil pressure is not adequate.

20. Ensure all electrical components are working properly.

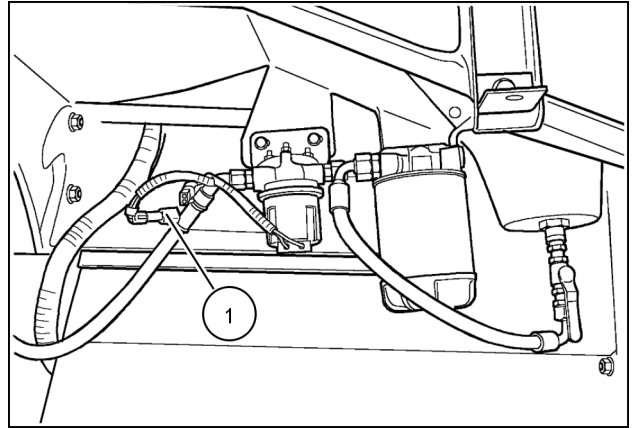

50030135 10

Next operation:
Engine hood - Install (90.105)

Engine - Remove

AXIAL-FLOW 8230 NA, AXIAL-FLOW 9230 NA

▲ WARNING

Avoid injury! Always do the following before lubricating, maintaining, or servicing the machine.

1. Disengage all drives.
 2. Engage parking brake.
 3. Lower all attachments to the ground, or raise and engage all safety locks.
 4. Shut off engine.
 5. Remove key from key switch.
 6. Switch off battery key, if installed.
 7. Wait for all machine movement to stop.
- Failure to comply could result in death or serious injury.

W0047A

▲ WARNING

Heavy objects!

Lift and handle all heavy components using lifting equipment with adequate capacity. Always support units or parts with suitable slings or hooks. Make sure the work area is clear of all bystanders.

Failure to comply could result in death or serious injury.

W0398A

Prior operation:

Engine hood - Remove (90.105) Engine cooling system - Drain fluid (10.400) Engine lubrication system - Drain fluid (10.304) Deaeration tank - Remove (10.400) Intake and exhaust manifolds and muffler - Remove (10.254) Engine cooling system - Remove (10.400) Fan and drive - Remove (10.414) Radiator - Remove (10.400) Air-conditioning compressor - Remove (50.200) Fuel supply lines Low pressure - Remove (10.210) Central wire harness - Remove (55.100)

1. Attach a suitable chain to the front lift eye (1) at the front of the engine.

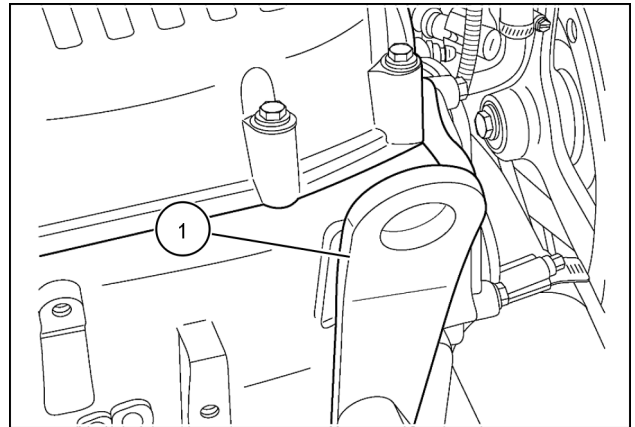

86070259 1

2. Attach a suitable chain to the back lift eye (1) at the rear of the engine.

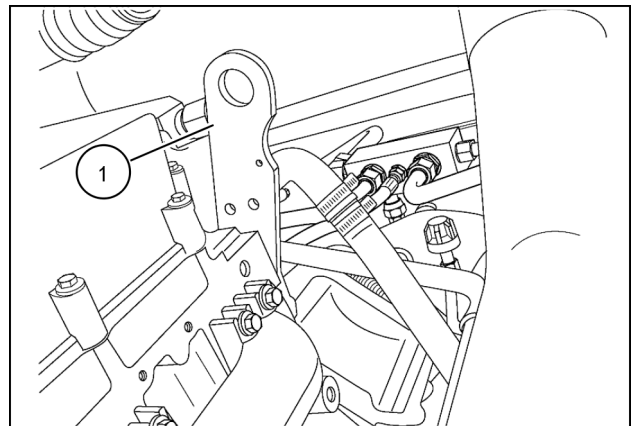

86070260 2

3. Connect the lift chain to a suitable lifting device.
4. Raise the lifting device enough to support the engine during removal of the engine mounting bolts.

NOTE: Illustration is for reference only. It may not be the actual engine.

NOTE: The lifting device should be rated for at least **907.2 kg (2000 lb)**. Allow enough clearance to lift the engine from the combine, approximately **7.0 m (23 ft)** from the floor.

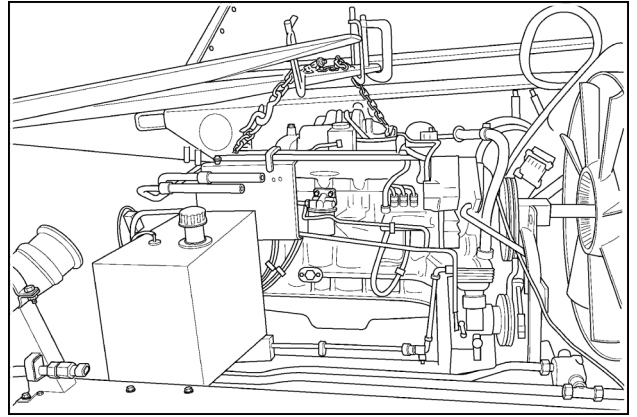

10013136 3

5. From inside the grain tank, loosen the front two engine mounting bolts (1). Do not remove the mounting bolts at this time.

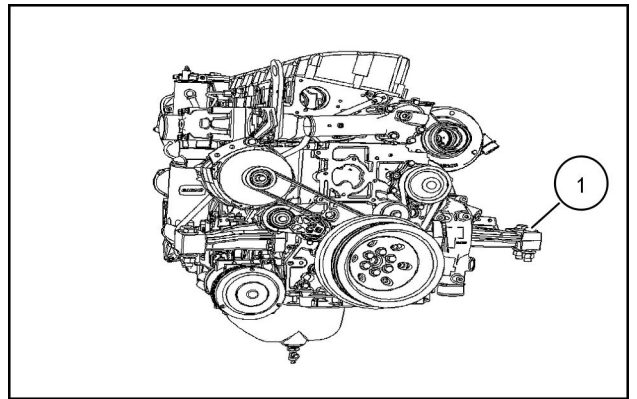

20107342 4

6. From the platform side, loosen the two front, engine mounting bolts (1). Do not remove the mounting bolts at this time.

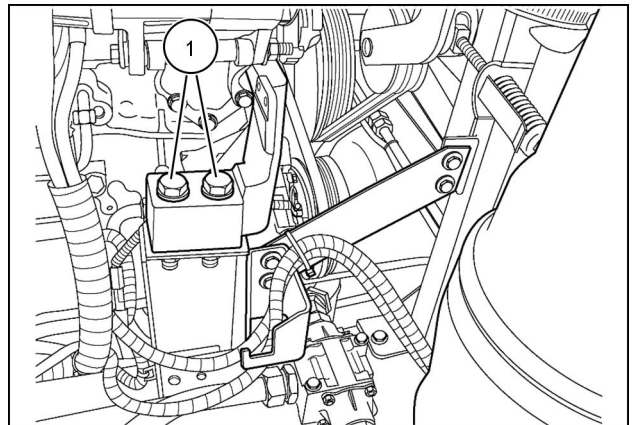

86070235 5

7. Loosen but do not remove all the bolts and washers (1) that couple the engine to the gearbox. There are twelve bolts and washers in total.
8. For safety reasons to the radiators, place a sheet of plywood, cut to size, in front of the cooler box for protection.
9. With the engine securely supported by the lifting device, remove all of the engine mounting bolts and the engine to the gearbox coupling bolts that were loosened in the previous steps.
10. Slide the engine towards the cooler box to disengage the flex plate from the gearbox input shaft.
11. Carefully lift the engine from the frame and remove from the combine.

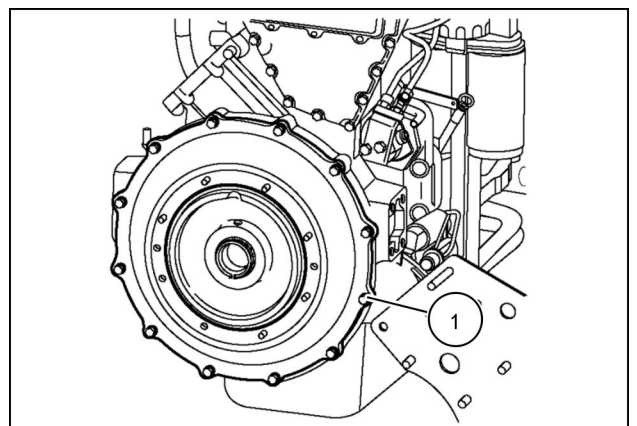

83090610 6

Engine - Install

AXIAL-FLOW 8230 NA, AXIAL-FLOW 9230 NA

Prior operation:

Engine - Remove (10.001)

1. Before installing the engine, apply **LOCTITE® 767 ANTI-SEIZE** to the input shaft **(1)** of the gearbox.

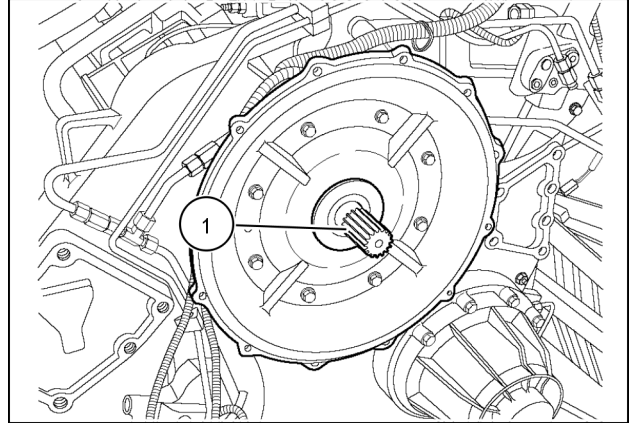

83070284 1

2. Attach a suitable chain to the front lift eye **(1)** at the front of the engine.

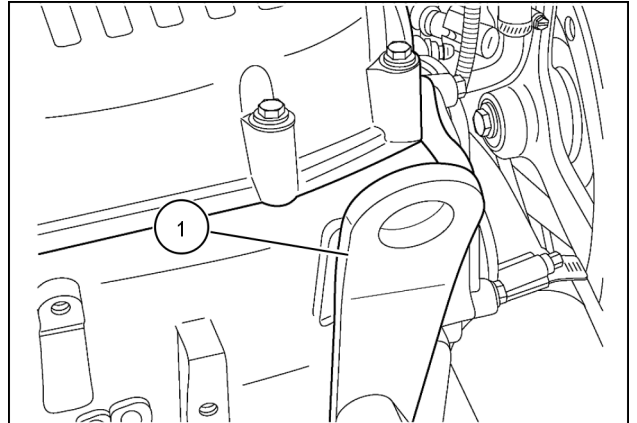

86070259 2

3. Attach a suitable chain to the back lift eye **(1)** at the rear of the engine.

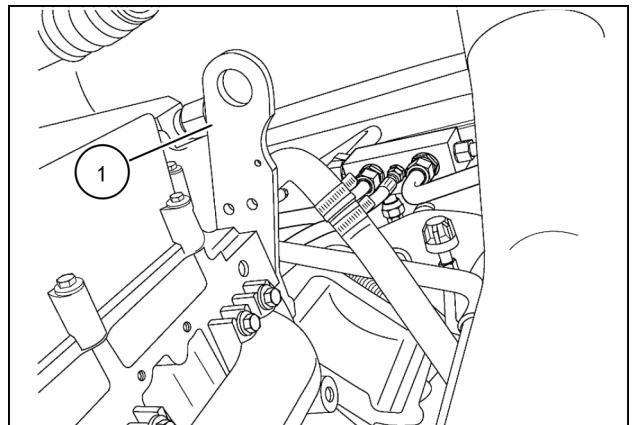

86070260 3

4. Connect the lift chain to a suitable lifting device.
5. Carefully lift the engine above the combine and lower into position in the frame.

NOTE: Illustration is for reference only. It may not be the actual engine.

NOTE: The lifting device should be rated for at least **907.2 kg (2000 lb)**. Allow enough clearance to lift the engine from the combine, approximately **907.2 kg (2000 lb)** from the floor.

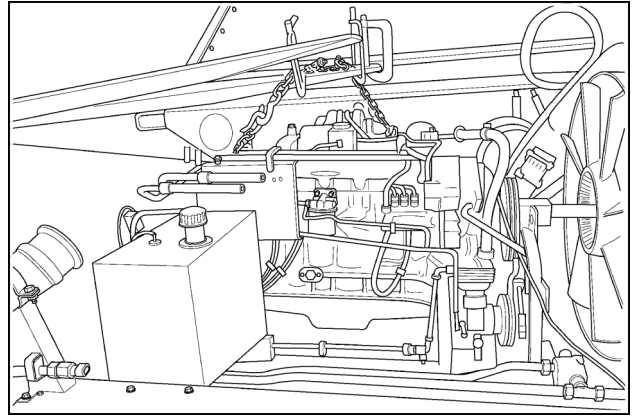

10013136 4

6. For safety reasons to the radiator, place a sheet of plywood, cut to size, in front of the radiator for protection.
7. Slide the engine towards the gearbox onto the gear box input shaft.
8. Align the holes of the gearbox with the engine and hand start a bolt with a washer (**1**) on each side of the coupling, going back and forth until all bolts with a washer are installed.

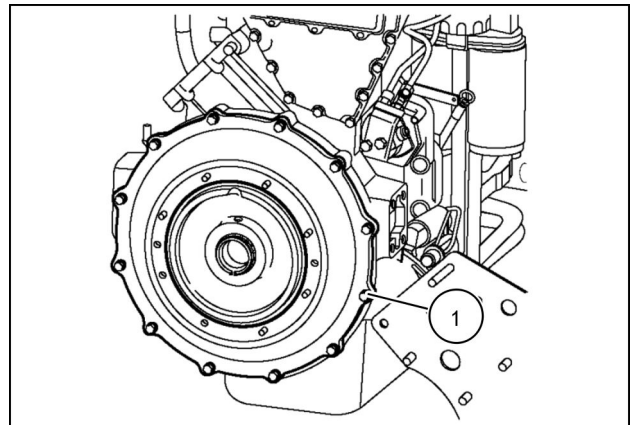

83090610 5

9. With the engine positioned in the frame, align the two front mounting holes on the grain tank side. Install the mounting hardware (**1**) into the mount. Do not tighten yet.

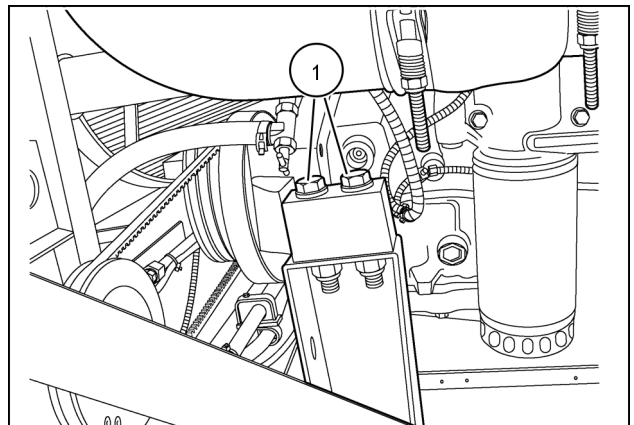

86070234 6

10. Align the two front mounting holes on the platform side. Install the mounting hardware **(1)** into the mount.
11. Tighten and torque the front engine mounting nuts to **217 Nm (160.1 lb ft)**.
12. Tighten and torque the engine gearbox cap screws to **41 - 51 Nm (30.2 - 37.6 lb ft)**.

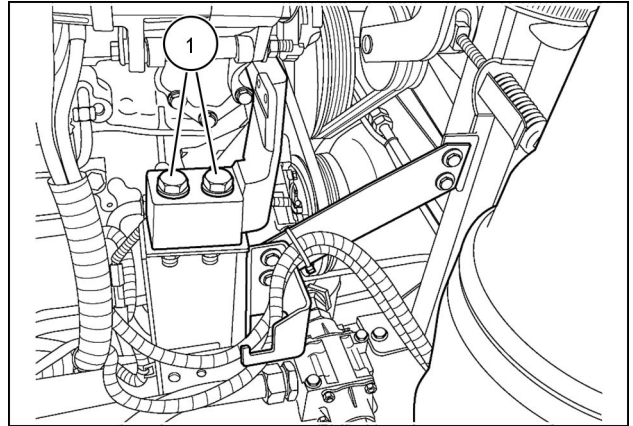

86070235 7

13. **Central wire harness - Install (55.100) Fuel supply lines Low pressure - Install (10.210) Air-conditioning compressor - Install (50.200) Fan and drive - Install (10.414) Radiator - Install (10.400) Engine cooling system - Install (10.400) Intake and exhaust manifolds and muffler - Install (10.254) Deaeration tank - Install (10.400) Engine lubrication system - Filling (10.304) Engine cooling system - Filling (10.400)**
14. Connect the battery cables to the batteries **(1)**.

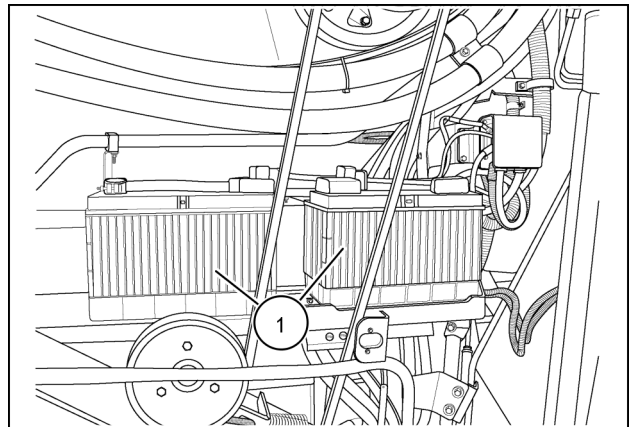

86063134 8

15. Disconnect the fuel pump wire connector **(1)** to disable the fuel pump **(2)**.
16. Check the engine oil level and top off if necessary.
17. Crank the engine over for three ten second intervals. This will distribute lubricating oil to the engine operating systems and will allow oil pressure to be built before starting the engine.

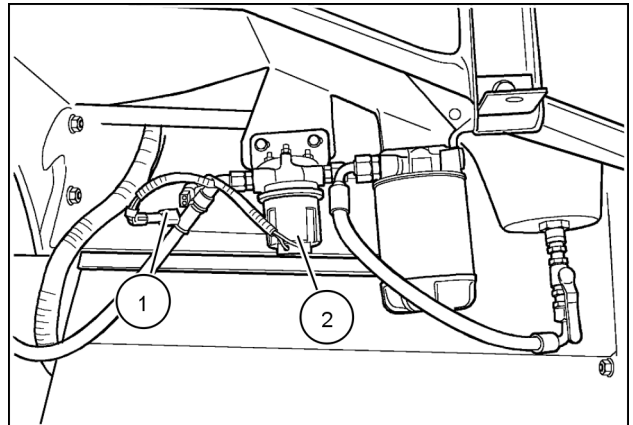

50030135 9



Suggest:

If the above button click is invalid.

Please download this document

first, and then click the above link

to download the complete manual.

Thank you so much for reading

18. Connect the fuel pump wire connector (1) and bleed the air from fuel injection system, as described in the Operators manual.
19. Start the engine and check all hoses, fittings and clamps for leaks.

NOTICE: Monitor the instrument warning light bar at all times during initial engine start up to ensure the engine has proper oil pressure. Shut down the engine immediately if oil pressure is not adequate.

20. Ensure all electrical components are working properly.

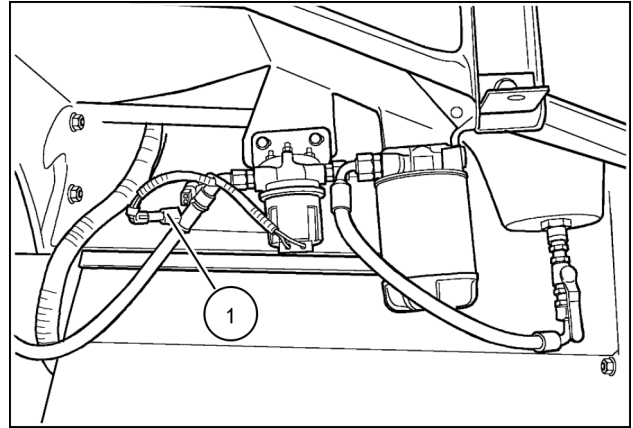

50030135 10

Next operation:
Engine hood - Install (90.105)

<https://www.ebooklibonline.com>

Hello dear friend!

Thank you very much for reading.

Enter the link into your browser.

The full manual is available for immediate download.

<https://www.ebooklibonline.com>