

**DV209C**  
**DV210C**  
**Tier 4A**  
Vibratory Roller

**SERVICE MANUAL**

**Part number 47772910**  
1<sup>st</sup> edition English  
December 2014



# Contents

---

## INTRODUCTION

Machine completion and equipment.....	05
[05.102] Machine completion.....	05.1
Engine.....	10
[10.001] Engine and crankcase.....	10.1
[10.216] Fuel tanks.....	10.2
[10.400] Engine cooling system.....	10.3
Hydrostatic drive.....	29
[29.218] Pump and motor components.....	29.1
Hydraulic systems.....	35
[35.000] Hydraulic systems.....	35.1
[35.300] Reservoir, cooler, and filters.....	35.2
[35.752] Hydraulic fan drive cooling system.....	35.3
[35.353] Hydraulic travel system.....	35.4
[35.995] Compaction/vibration hydraulic system.....	35.5
Frames and ballasting.....	39
[39.100] Frame.....	39.1
[39.500] Vibratory roller.....	39.2
Steering.....	41
[41.101] Steering control.....	41.1
[41.200] Hydraulic control components.....	41.2
[41.206] Pump.....	41.3
[41.216] Cylinders.....	41.4
Wheels.....	44
[44.160] Compaction drums.....	44.1
Cab climate control.....	50

[50.100] Heating .....	50.1
<b>Electrical systems .....</b>	<b>55</b>
[55.100] Harnesses and connectors.....	55.1
[55.301] Alternator.....	55.2
[55.302] Battery.....	55.3
[55.512] Cab controls.....	55.4
[55.050] Heating, Ventilation, and Air-Conditioning (HVAC) control system.....	55.5
[55.408] Warning indicators, alarms, and instruments .....	55.6
<b>Platform, cab, bodywork, and decals .....</b>	<b>90</b>
[90.150] Cab.....	90.1

**<https://www.ebooklibonline.com>**

Hello dear friend!

Thank you very much for reading.

Enter the link into your browser.

The full manual is available for immediate download.

**<https://www.ebooklibonline.com>**



## INTRODUCTION

---

## **Foreword - Important notice regarding equipment servicing**

All repair and maintenance work listed in this manual must be carried out only by qualified dealership personnel, strictly complying with the instructions given, and using, whenever possible, the special tools.

Anyone who performs repair and maintenance operations without complying with the procedures provided herein shall be responsible for any subsequent damages.

The manufacturer and all the organizations of its distribution chain, including - without limitation - national, regional, or local dealers, reject any responsibility for damages caused by parts and/or components not approved by the manufacturer, including those used for the servicing or repair of the product manufactured or marketed by the manufacturer. In any case, no warranty is given or attributed on the product manufactured or marketed by the manufacturer in case of damages caused by parts and/or components not approved by the manufacturer.

The manufacturer reserves the right to make improvements in design and changes in specifications at any time without notice and without incurring any obligation to install them on units previously sold. Specifications, descriptions, and illustrative material herein are as accurate as known at time of publication but are subject to change without notice.

In case of questions, refer to your CASE CONSTRUCTION Sales and Service Networks.

## Safety rules

### Personal safety





This is the safety alert symbol. It is used to alert you to potential personal injury hazards. Obey all safety messages that follow this symbol to avoid possible death or injury.

Throughout this manual you will find the signal words DANGER, WARNING, and CAUTION followed by special instructions. These precautions are intended for the personal safety of you and those working with you.

Read and understand all the safety messages in this manual before you operate or service the machine.

 DANGER indicates a hazardous situation that, if not avoided, will result in death or serious injury.

 WARNING indicates a hazardous situation that, if not avoided, could result in death or serious injury.

 CAUTION indicates a hazardous situation that, if not avoided, could result in minor or moderate injury.

**FAILURE TO FOLLOW DANGER, WARNING, AND CAUTION MESSAGES COULD RESULT IN DEATH OR SERIOUS INJURY.**

### Machine safety

**NOTICE:** Notice indicates a situation that, if not avoided, could result in machine or property damage.

Throughout this manual you will find the signal word Notice followed by special instructions to prevent machine or property damage. The word Notice is used to address practices not related to personal safety.

### Information

**NOTE:** Note indicates additional information that clarifies steps, procedures, or other information in this manual.

Throughout this manual you will find the word Note followed by additional information about a step, procedure, or other information in the manual. The word Note is not intended to address personal safety or property damage.

## Safety rules

Carefully read the safety rules contained herein and follow advised precautions to avoid potential hazards and to safeguard your safety and personal integrity.

Your safety and that of the people around you depends on you.

It is essential that you understand this manual for a correct inspection, lubrication and repair of this machine.

Read this manual carefully and check that:

- You understand fully the symbols on the controls and the safety signs used in this manual and on the machine.
- You understand fully the speed, stability, braking and steering characteristics of the machine. If you are in any doubt, consult your Dealer.

The safety messages in this section concern situations which may arise during normal machine operation, servicing and repair. These safety messages also indicate the different ways of coping with these situations. Other safety messages are used throughout the manual to indicate specific dangers.

The information given in this chapter is a summary of the basic rules to respect at all times and does not exempt you from observing traffic regulations or the requirements of insurance companies.

The presence of grease, oil, mud or (in winter) ice on the steps and access handles can cause accidents. Make sure they are always clean.

When mounting or dismounting from the machine always face the machine and use the steps and access handles on the left-hand side of the machine.

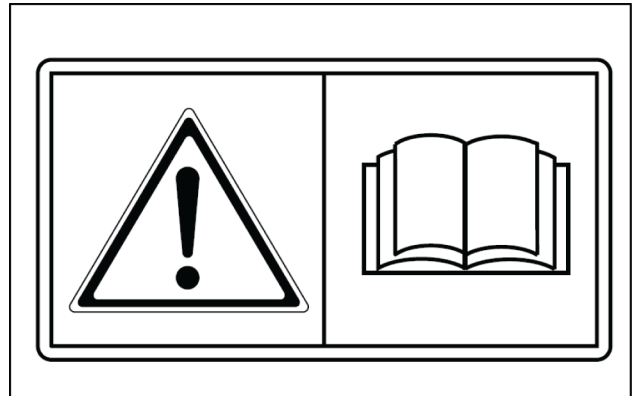

LELI12TLB0048AB 1

Wear close fitting clothing and safety equipment appropriate for the job:

- Safety helmet
- Safety shoes
- Heavy gloves
- Reflective clothing
- Wet weather clothing

If the environment conditions make it necessary, the following personal safety equipment should be at hand:

- Respirators (or dustproof masks)
- Ear plugs or acoustic ears protections
- Goggles with lateral shield or masks for eyes protection

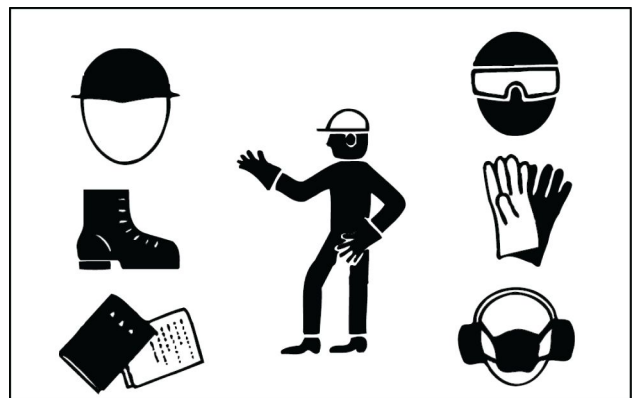

LELI12TLB0049AB 2

Do not wear rings, wristwatches, jewels, unbuttoned or flapping clothing such as ties, torn clothes, scarves, open jackets or shirts with open zips which could get caught into moving parts.

Any functional disorders, especially those affecting the safety of the machine, should therefore be rectified immediately.

# Product identification

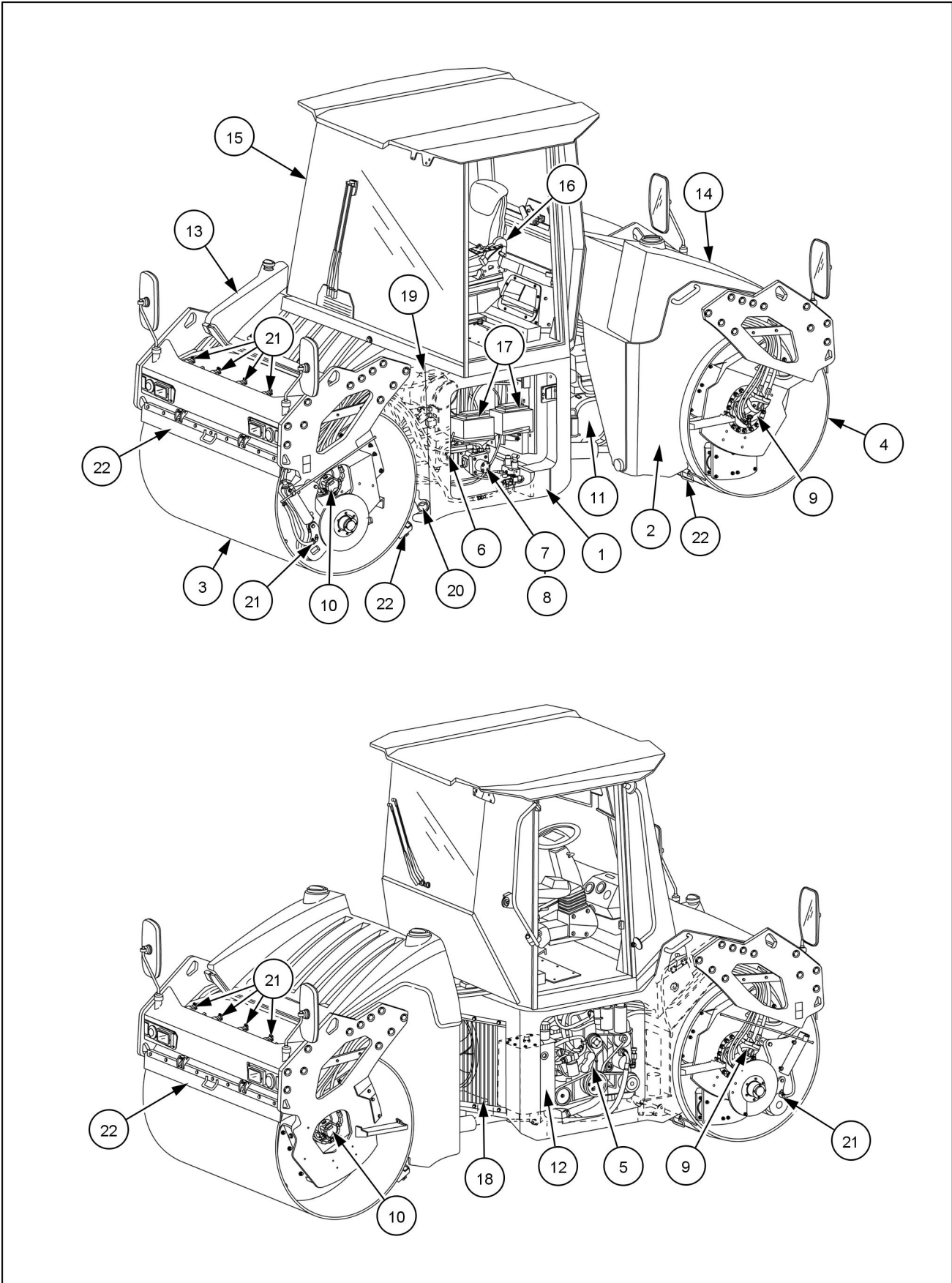

RAIL14COM0271HC 1

## INTRODUCTION

---

1. Front frame
2. Rear frame
3. Front drum
4. Rear drum
5. Engine
6. Hydrostatic pump for travel (roll)
7. Hydrostatic pump for vibration of front drum
8. Hydrostatic pump vibration of rear drum
9. Travel hydrostatic motor
10. Vibration hydrostatic motor
11. Steering joint
12. Hydraulics tank
13. Fuel tank
14. Sprinkling tank
15. Cab with integrated Roll Over Protective Structure (ROPS) frame
16. Driver's control stand
17. Batteries
18. Combined cooler
19. Air filter
20. Exhaust pipe
21. Sprinkling jets
22. Drum scrapers



# **SERVICE MANUAL**

**Engine**

**DV209C  
DV210C**

## Engine - General specification

Engine type	TCD 3.6 L4
Working principle	Four-stroke diesel engine
Charging	Turbocharger with charge air cooling
Type of cooling	water-cooled
Cylinder arrangement	in series
No. of cylinders	4
Bore/stroke	<b>98 mm (3.86 in) / 120 mm (4.72 in)</b>
Total displacement	<b>3621 cm<sup>3</sup> (221 in<sup>3</sup>)</b>
Combustion process	Direct injection
Injection system	Common Rail
Exhaust gas recirculation	externally cooled
Exhaust gas aftertreatment	Diesel oxidation catalytic converter DOC
Valves per cylinder	2
Firing order of the engine	1-3-4-2
Direction of rotation looking onto the flywheel	left
Engine power rating according to ISO 3046	See engine rating plate
Speed (nominal revolutions)	See engine rating plate
Injection timing	See engine rating plate
Coolant volume	<b>4.6 L (1.22 US gal)</b>
Permissible continuous coolant temperature	max. <b>110 °C (230 °F)</b>
Temperature difference between coolant inlet/outlet	<b>8 °C (15 °F)</b>
Start of thermostat opening	<b>88 °C (190 °F)</b>
Thermostat fully open	<b>95 °C (203 °F)</b>
Lubricating oil change volume (with filter)	<b>8 L (2.1 US gal)</b>
Lube oil temperature in the lube oil tray, maximum	<b>125 °C (257 °F)</b>
Lubricating oil pressure minimum (low idle, engine warm)	<b>80 kPa (11.6 psi)</b>
Permissible maximum combustion air temperature after charge air cooler	<b>50 °C (122 °F)</b>
V-belt tension: V-belts AVX (width: 13 mm)	Pre-tensioning: <b>600 - 700 N (134.9 - 157.4 lb)</b> Re-tensioning: <b>350 - 450 N (78.7 - 101.2 lb)</b>
V-rib belt tensioning	Automatic tensioning spring-loaded clamping roller
Weight without cooling system according to DIN 70020-A	<b>350 kg (772 lb)</b>

## Engine - Component identification

Engine name plate (1)

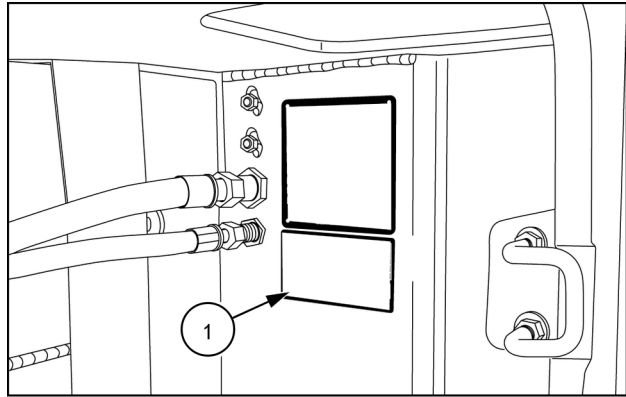

RAIL14COM0213AA 1

### View from right

1. Crankcase breather
2. Throttle valve
3. Tension pulley
4. V-rib belt
5. Coolant inlet
6. Lubricating oil drain plug
7. Lube oil replacement filter
8. Lubricating oil dipstick
9. Coolant outlet

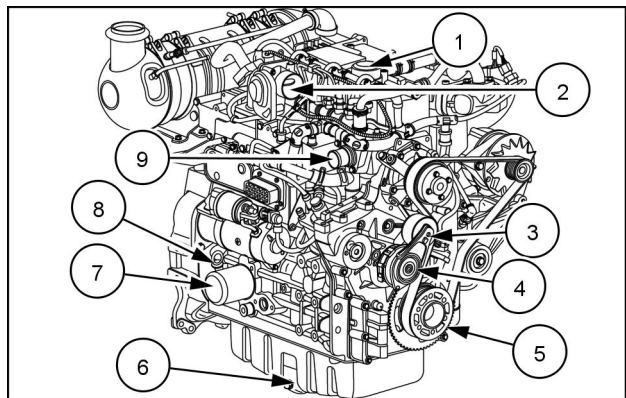

RAIL14COM0408AA 2

### View from left

1. Combustion air inlet
2. Exhaust outlet
3. Diesel particle filter
4. Diesel oxidation catalytic converter
5. Lubricating oil dipstick - Optional
6. Lube oil replacement filter - Optional
7. Lubricating oil filling

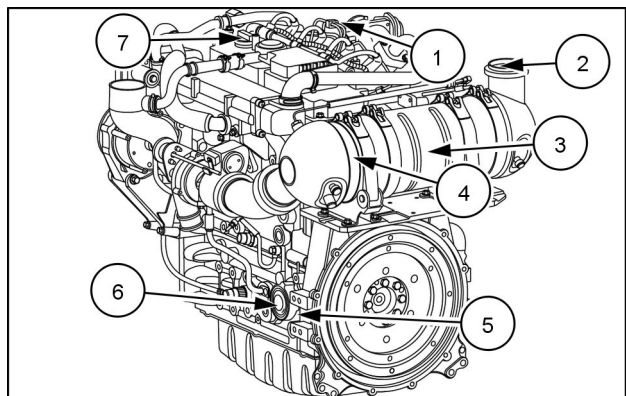

RAIL14COM0409AA 3

## Electronic engine control

1. Rail pressure sensor
2. Charge air pressure transmitter, charge air temperature transmitter
3. Coolant temperature transmitter
4. Engine control unit
5. Speed transmitter via camshaft
6. Speed transmitter via crankshaft
7. Fuel transducer
8. Lubricating oil pressure transmitter (on the opposite side)
9. Central plug (for engine control)

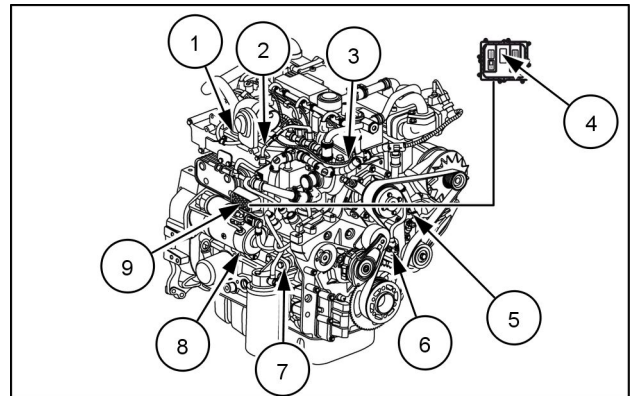

RAIL14COM0410AA 4

## Engine - Remove

1. Remove the cab (refer to **Cab - Remove (90.150)**).
2. Remove the platform (refer to **Cab and platform - Remove (90.150)**).
3. Remove the vibration pump for the front drum (refer to **Pump - Remove the pump for front drum vibrations (29.218)** ).
4. Remove the vibration pump for the rear drum (refer to **Pump - Remove the pump for rear drum vibrations (29.218)** ).
5. Remove the travel pump (refer to **Pump - Remove the travel pump (29.218)** ).
6. Place a suitable drain collector with adequate capacity under the frame to collect the drain oil.

**NOTE:** *Approximate drain volume: 9 L (2.4 US gal).*

7. Remove the drain plugs and drain the engine oil.

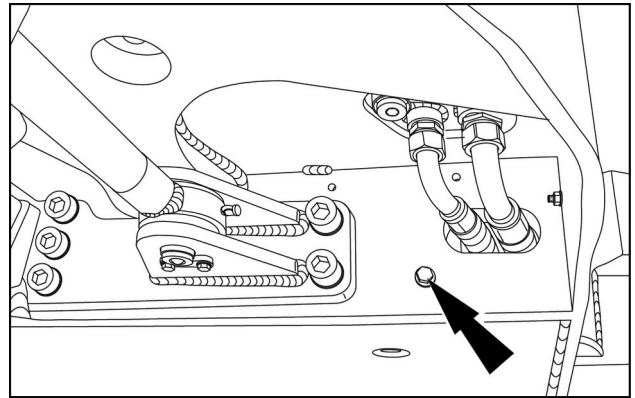

RAIL14COM0411AA 1

8. Remove the tie wraps as required.

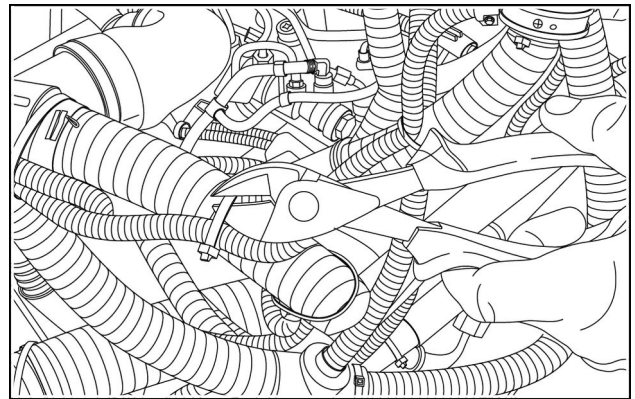

RAIL14COM0412AA 2

9. Remove the Engine Control Unit (ECU) (1).
10. Remove the ECU bracket (2).

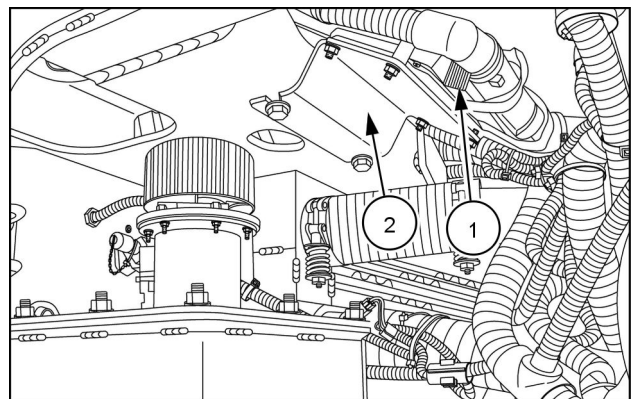

RAIL14COM0413AA 3

11. Remove the bracket **(3)** and attaching hardware.
12. Disconnect the connectors **(4)** from the bracket **(3)**.

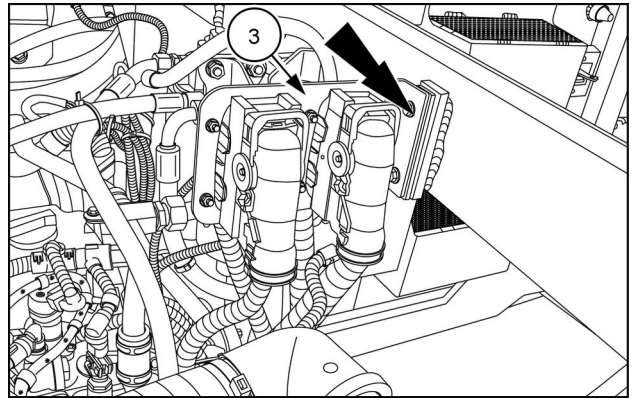

RAIL14COM0414AA 4

13. Disconnect the connectors **(4)** from the ECU **(1)**.
14. Plug the connectors with protective caps and store the ECU appropriately.

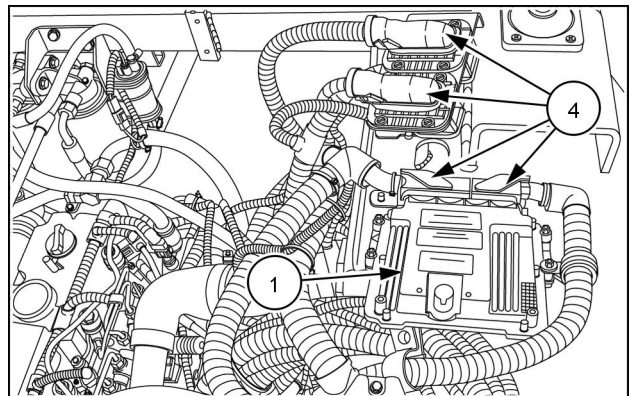

RAIL14COM0415AA 5

15. Remove the clamps **(5)** and **(6)**.
16. Remove the ducts **(7)**, **(8)** and **(9)** and clamps **(5)** from the intercooler **(10)**.

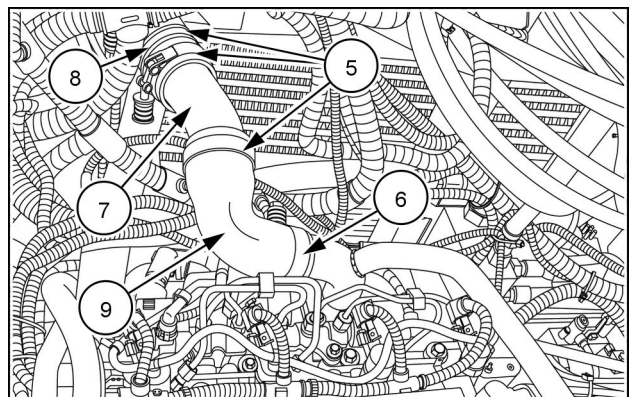

RAIL14COM0416AA 6

17. Remove the clamps **(5)** and **(11)**.
18. Remove the clamp **(15)** and attaching hardware.
19. Remove the ducts **(12)**, **(13)** and **(14)** and clamps **(23)** from the intercooler **(10)**.

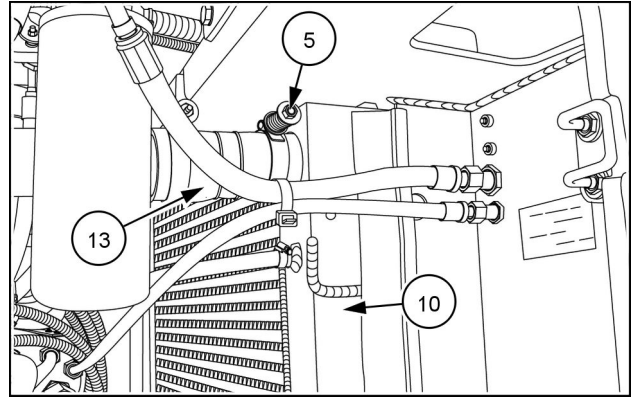

RAIL14COM0417AA 7

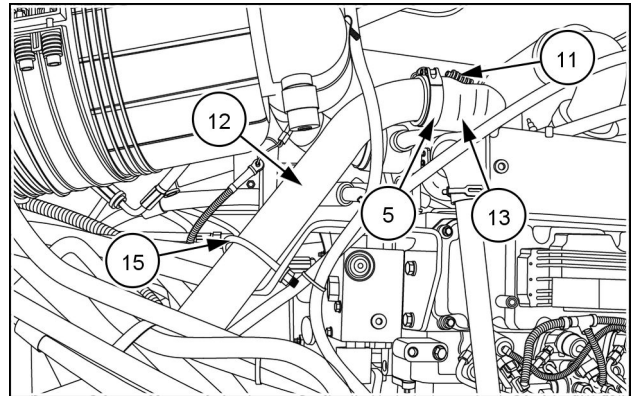

RAIL14COM0418AA 8

20. Remove the clamp **(16)**.
21. Disconnect the duct **(17)** from the turbocharger.

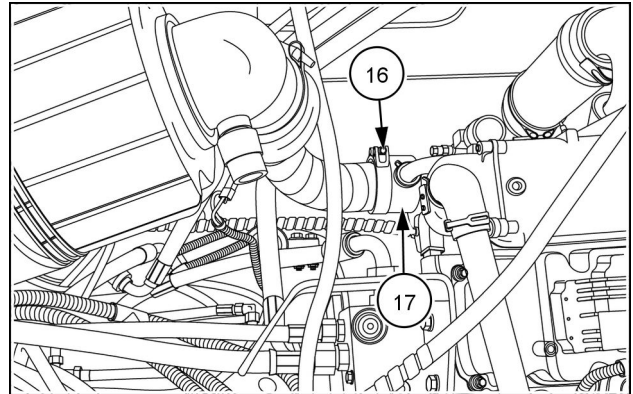

RAIL14COM0419AA 9

22. Remove the clamps **(18)**.
23. Remove the duct **(19)** and gaskets **(20)**.

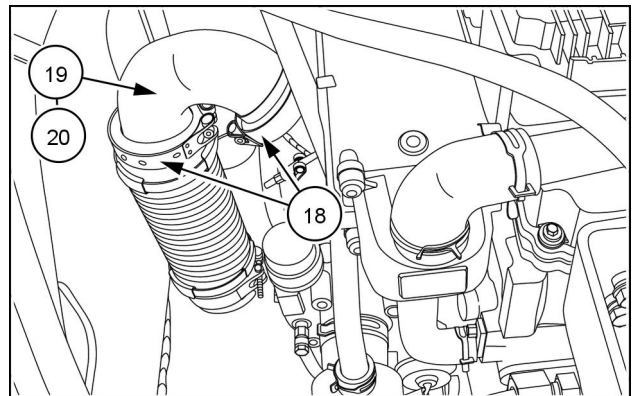

RAIL14COM0420AA 10

24. Close the fuel shut-off valves (21).

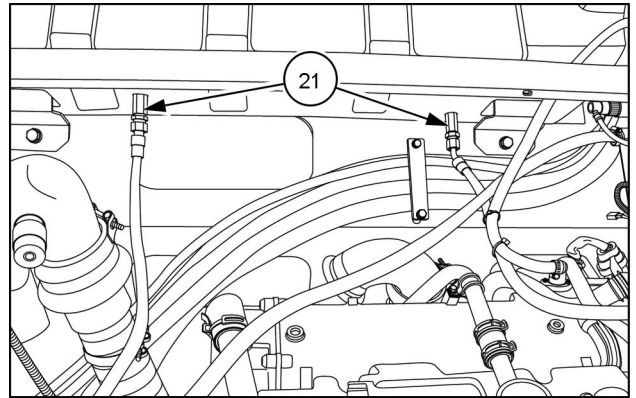

RAIL14COM0421AA 11

25. Disconnect the connector (X12) from the fuel pump.

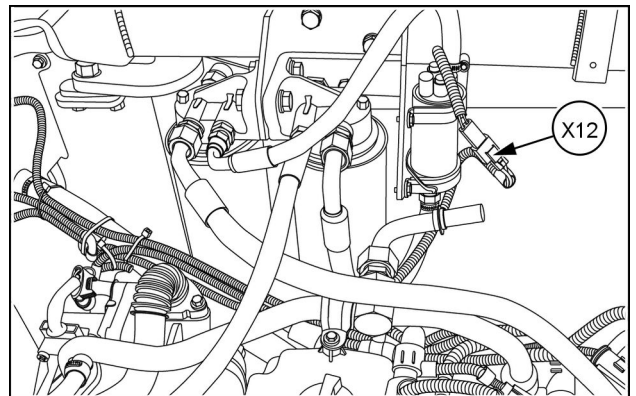

RAIL14COM0422AA 12

26. Disconnect the connector (A) from the fuel pressure sensor.

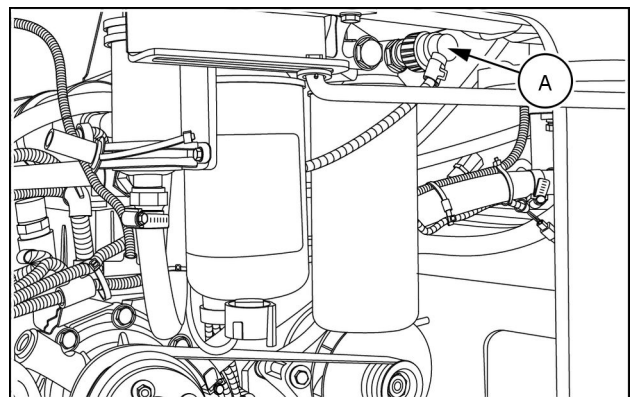

RAIL14COM0423AA 13

27. Disconnect the connector from the Water in fuel switch (S38).

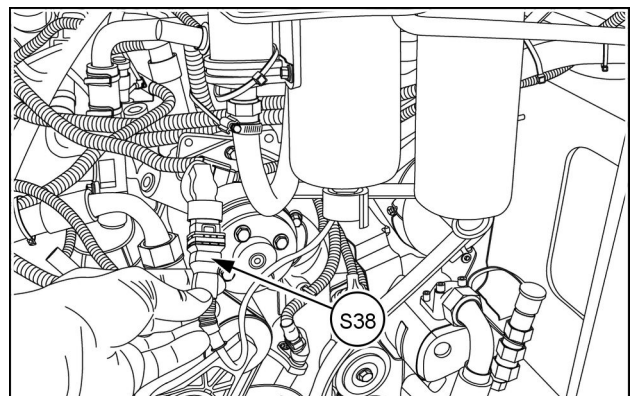

RAIL14COM0424AA 14

28. Remove the hoses (22) and (23) from the filter assemblies.

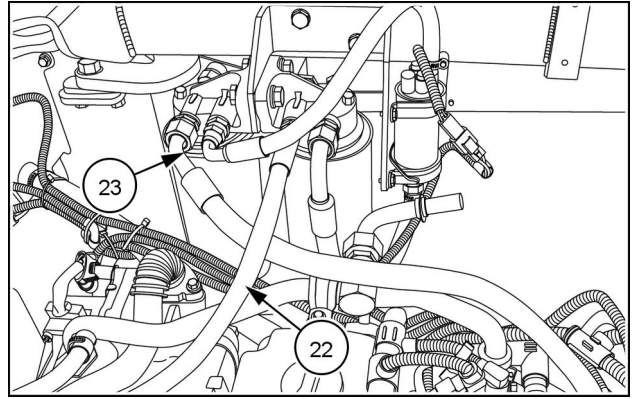

RAIL14COM0425AA 15

29. Remove the attaching hardware (28) and bracket (24) with the filter assemblies.

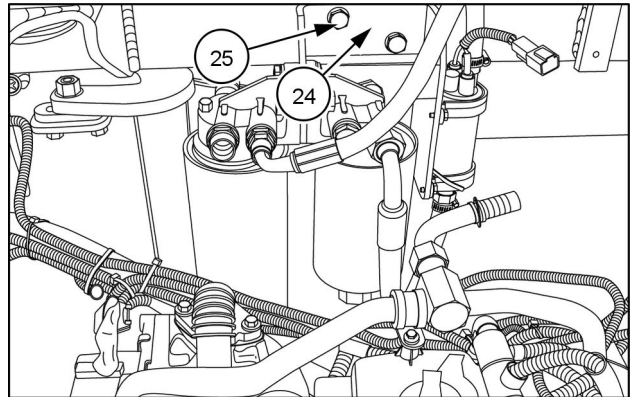

RAIL14COM0426AA 16

30. Disconnect the connector from the coolant level sensor (S36).

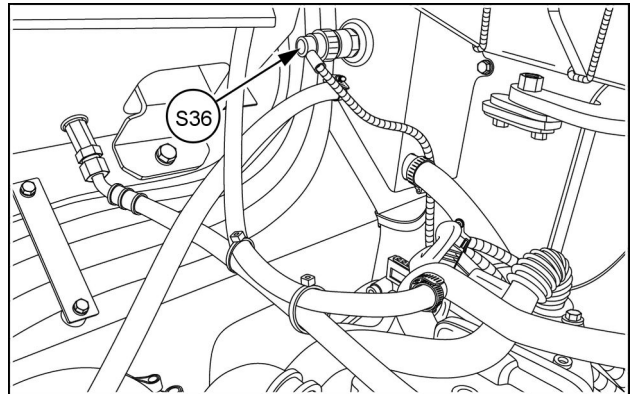

RAIL14COM0427AA 17

31. Disconnect the hoses (27) and (28) from the expansion tank (26).

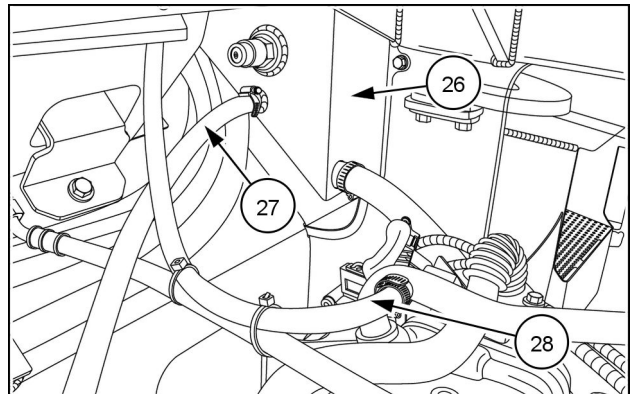

RAIL14COM0428AA 18



**Suggest:**

**If the above button click is invalid.**

**Please download this document**

**first, and then click the above link**

**to download the complete manual.**

**Thank you so much for reading**

32. Remove the clamps and disconnect the hose (29) from the coolant pump.

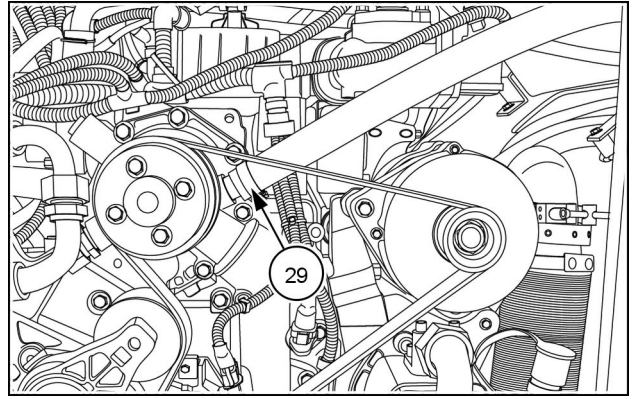

RAIL14COM0429AA 19

33. Remove the attaching hardware and bracket (30) with the differential lock valve (31).

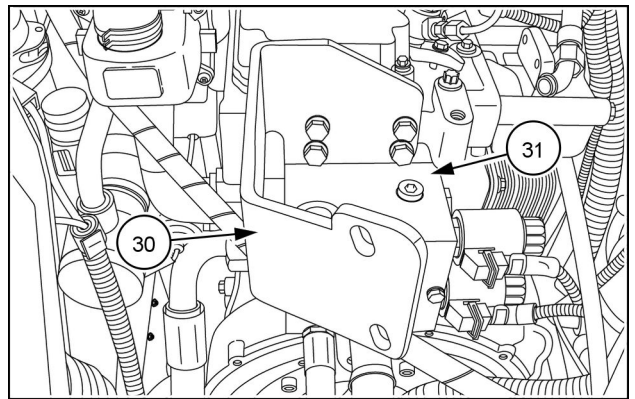

RAIL14COM0430AA 20

34. Move the bracket assembly (30) out of the work area and secure it with a tie-wrap.

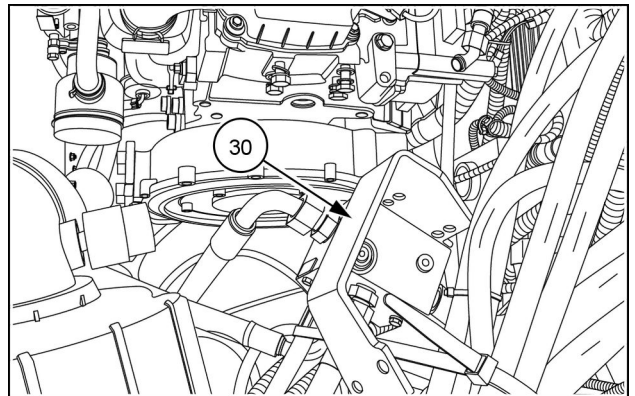

RAIL14COM0431AA 21

35. Disconnect the D+ terminal from the alternator.

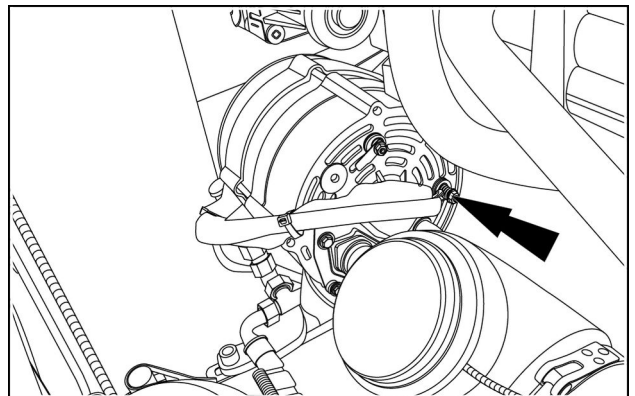

RAIL14COM0432AA 22

**<https://www.ebooklibonline.com>**

Hello dear friend!

Thank you very much for reading.

Enter the link into your browser.

The full manual is available for immediate download.

**<https://www.ebooklibonline.com>**