

DV23
DV26
Tier 4A (interim)
Vibratory Roller

DV23CC
DV26CC
Tier 4A (interim)
Combination Roller

SERVICE MANUAL

Part number 48142067

1st edition English

September 2017

Replaces part number 47538930

CASE
CONSTRUCTION

Contents

INTRODUCTION

Maintenance	00
[00.150] Start-up.....	00.1
Engine.....	10
[10.001] Engine and crankcase	10.1
[10.400] Engine cooling system	10.2
Hydrostatic drive.....	29
[29.218] Pump and motor components.....	29.1
Brakes and controls	33
[33.110] Parking brake or parking lock	33.1
[33.202] Hydraulic service brakes	33.2
Hydraulic systems.....	35
[35.104] Fixed displacement pump.....	35.1
[35.000] Hydraulic systems.....	35.2
[35.102] Pump control valves.....	35.3
[35.353] Hydraulic travel system	35.4
[35.300] Reservoir, cooler, and filters.....	35.5
[35.995] Compaction/vibration hydraulic system	35.6
Frames and ballasting	39
[39.100] Frame	39.1
Steering.....	41
[41.101] Steering control	41.1
Wheels	44
[44.160] Compaction drums	44.1
Electrical systems	55
[55.031] Parking brake electrical system	55.1

[55.000] Electrical system	55.2
[55.019] Hydrostatic drive control system	55.3
[55.100] Harnesses and connectors.....	55.4
[55.408] Warning indicators, alarms, and instruments	55.5
[55.512] Cab controls.....	55.6
[55.640] Electronic modules	55.7
[55.404] External lighting	55.8
[55.DTC] FAULT CODES.....	55.9
Tools	89
[89.165] Water kit.....	89.1
Platform, cab, bodywork, and decals	90
[90.100] Engine hood and panels	90.1
[90.110] Operator platform less cab	90.2

<https://www.ebooklibonline.com>

Hello dear friend!

Thank you very much for reading.

Enter the link into your browser.

The full manual is available for immediate download.

<https://www.ebooklibonline.com>



INTRODUCTION

Safety rules

Personal safety





This is the safety alert symbol. It is used to alert you to potential personal injury hazards. Obey all safety messages that follow this symbol to avoid possible death or injury.

Throughout this manual you will find the signal words DANGER, WARNING, and CAUTION followed by special instructions. These precautions are intended for the personal safety of you and those working with you.

Read and understand all the safety messages in this manual before you operate or service the machine.

 DANGER indicates a hazardous situation that, if not avoided, will result in death or serious injury.

 WARNING indicates a hazardous situation that, if not avoided, could result in death or serious injury.

 CAUTION indicates a hazardous situation that, if not avoided, could result in minor or moderate injury.

FAILURE TO FOLLOW DANGER, WARNING, AND CAUTION MESSAGES COULD RESULT IN DEATH OR SERIOUS INJURY.

Machine safety

NOTICE: Notice indicates a situation that, if not avoided, could result in machine or property damage.

Throughout this manual you will find the signal word Notice followed by special instructions to prevent machine or property damage. The word Notice is used to address practices not related to personal safety.

Information

NOTE: Note indicates additional information that clarifies steps, procedures, or other information in this manual.

Throughout this manual you will find the word Note followed by additional information about a step, procedure, or other information in the manual. The word Note is not intended to address personal safety or property damage.

Safety rules - Ecology and the environment

When legislation does not yet rule the treatment of some of the substances required by advanced technology, sound judgment should govern the use and disposal of products of a chemical and petrochemical nature.

NOTE: *The following are recommendations that may be of assistance:*

- Become acquainted with and ensure that you understand the relative legislation applicable to your country.
- Where no legislation exists, obtain information from suppliers of oils, filters, batteries, fuels, antifreeze, cleaning agents, etc., with regard to their effect on man and nature and how to safely store, use, and dispose of these substances.

Helpful hints

- Avoid filling tanks using cans or inappropriate pressurized fuel delivery systems that may cause considerable spillage.
- In general, avoid skin contact with all fuels, oils, acids, solvents, etc. Most of them contain substances that may be harmful to your health.
- Modern oils contain additives. Do not burn contaminated fuels and or waste oils in ordinary heating systems.
- Avoid spillage when draining off used engine coolant mixtures, engine, gearbox and hydraulic oils, brake fluids, etc. Do not mix drained brake fluids or fuels with lubricants. Store them safely until they can be disposed of in a proper way to comply with local legislation and available resources.
- Modern coolant mixtures, i.e. antifreeze and other additives, should be replaced every two years. They should not be allowed to get into the soil, but should be collected and disposed of properly.
- Repair any leaks or defects in the engine cooling or hydraulic system immediately.
- Do not increase the pressure in a pressurized circuit as this may lead to a component failure.
- Protect hoses during welding as penetrating weld splatter may burn a hole or weaken them, allowing the loss of oils, coolant, etc.

Safety rules - Shop and assembly

O-ring seals

Lubricate the O-ring seals before you insert them in the seats. This will prevent the O-ring seals from overturning and twisting, which would jeopardize sealing efficiency.

Sealing compounds

Apply a sealing compound on the mating surfaces when specified by the procedure. Before you apply the sealing compound, prepare the surfaces as directed by the product container.

Spare parts

Only use CNH Original Parts.

Only genuine spare parts guarantee the same quality, duration, and safety as original parts, as they are the same parts that are assembled during standard production. Only CNH Original Parts can offer this guarantee.

When ordering spare parts, always provide the following information:

- Machine model (commercial name) and Product Identification Number (PIN)
- Part number of the ordered part, which can be found in the parts catalog



SERVICE MANUAL

Engine

**DV23CC
DV23
DV26CC
DV26**

Engine - Adjust

NOTICE: Make sure to adjust the speed while the roller is at its operating temperature.

1. Put the machine on two large or four small old tires or on a suitably soft base.

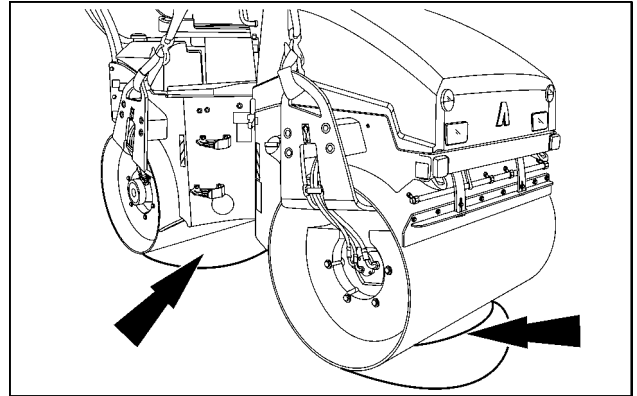

SVIL13COM0520AB 1

2. Move the speed lever to the highest setting:
100% = Fast speed = Reference value of 2360 – 2400 RPM

NOTICE: Do not exceed the maximum engine speed of **2400 RPM!**

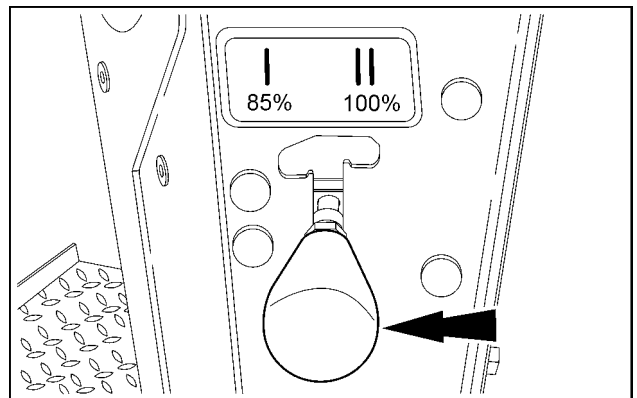

SVIL13COM0507AB 2

3. Switch on front and rear vibration.
4. Use a tachometer to measure the frequency.
100% = Desired value: 66 Hz
85% = Desired value: 58 Hz

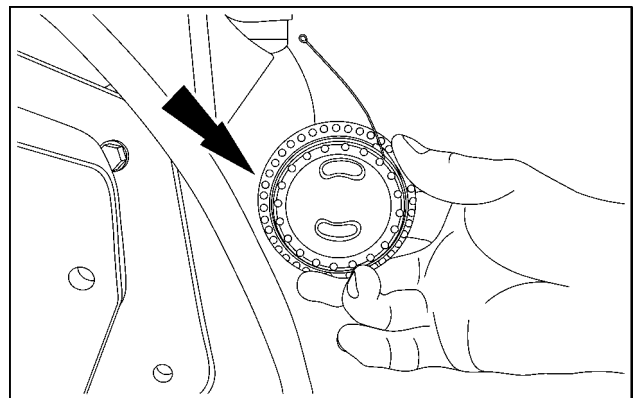

SVIL13COM0058AB 3

5. If necessary, adjust the speed on the cable knuckle (1) or on the ballhead (2).

NOTE: Source the tachometer locally.

6. Tighten the nuts.
7. Check the fastening (3) on the ball head.

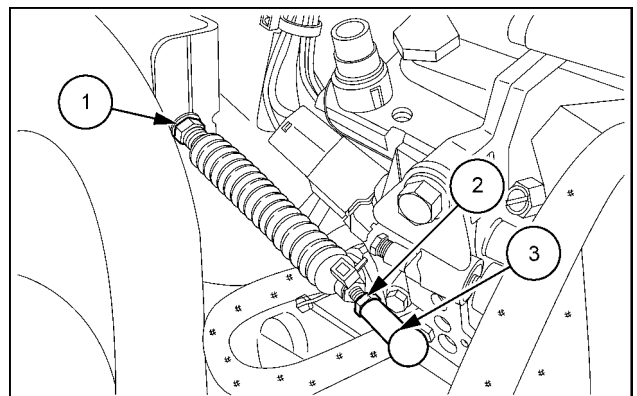

SVIL13COM0056AB 4

Engine RPM

	At the beginning	After 60 min
Engine RPM, 100%	2410 – 2450 RPM	2360 – 2400 RPM
Engine RPM, 85%	2080 – 2180 RPM	2000 – 2100 RPM
Simple vibration speed, front	3950 – 4050 RPM	3950 – 4050 RPM
Double vibration, front	3950 – 4050 RPM	3950 – 4050 RPM
Double vibration, rear	3400 – 3600 RPM	3400 – 3600 RPM
Engine RPM under load (driving and double vibration)	2350 – 2400 RPM	2350 – 2400 RPM

Pressures

	At the beginning	After 60 min
Pressures during MA and MB driving operation	85 – 115 bar (1232 – 1668 psi)	85 – 115 bar (1232 – 1668 psi)
Pressures for vibratory operation, front	40 – 80 bar (580 – 1160 psi)	27 – 43 bar (392 – 624 psi)
Pressures for vibratory operation, front and rear	80 – 140 bar (1160 – 2030 psi)	55 – 75 bar (798 – 1088 psi)

NOTE: This results in the lower speed, i.e. medium level. Frequency 58 Hz.

Engine - Remove

⚠ DANGER

Heavy objects!

Lift and handle all heavy components using lifting equipment with adequate capacity. Always support units or parts with suitable slings or hooks. Make sure the work area is clear of all bystanders. Failure to comply will result in death or serious injury.

D0076A

1. Support the hood with a suitable lifting device.
2. Disconnect the lamps (1).
3. Disconnect the hood strut (2).
4. Remove the bolts (3) on the hood hinge.
5. Repeat steps 2 – 4 on the opposite side.
6. Remove the hood.

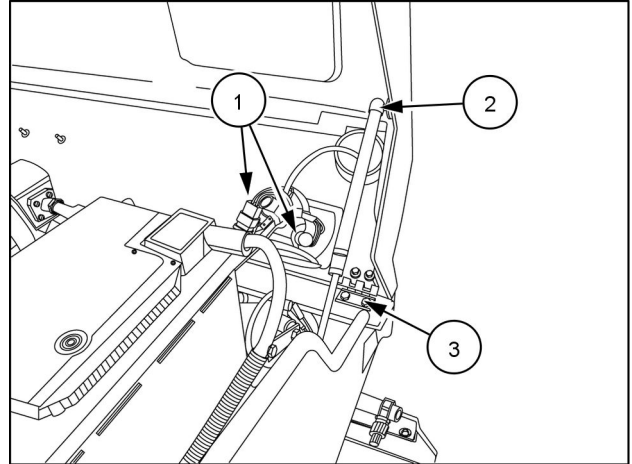

RAIL13SSL0079BA 1

7. Disconnect the negative battery cable.

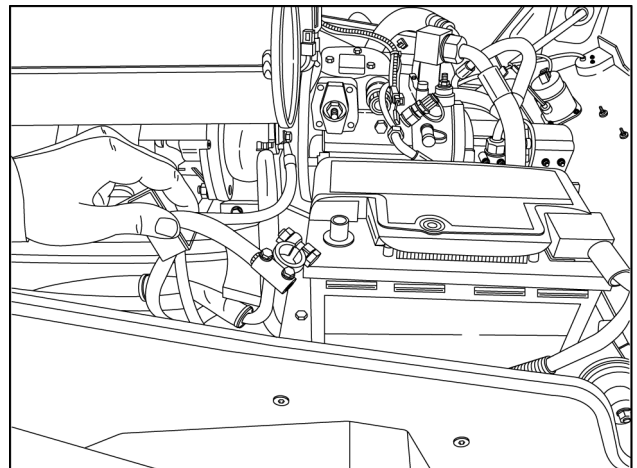

RAIL13SSL0061BA 2

8. Remove the U-bolt (1).

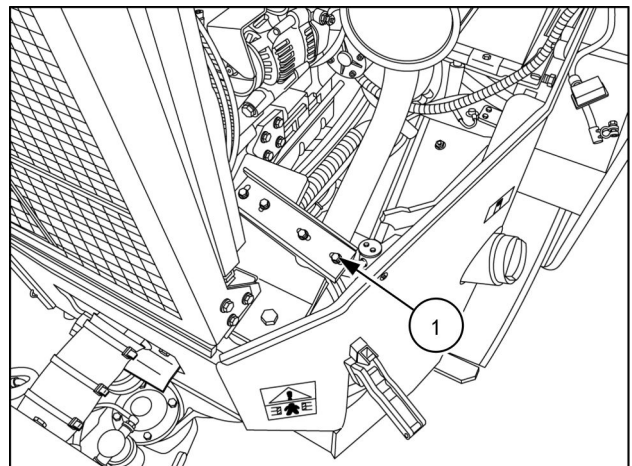

RAIL13SSL0051BA 3

9. Disconnect and remove the muffler.

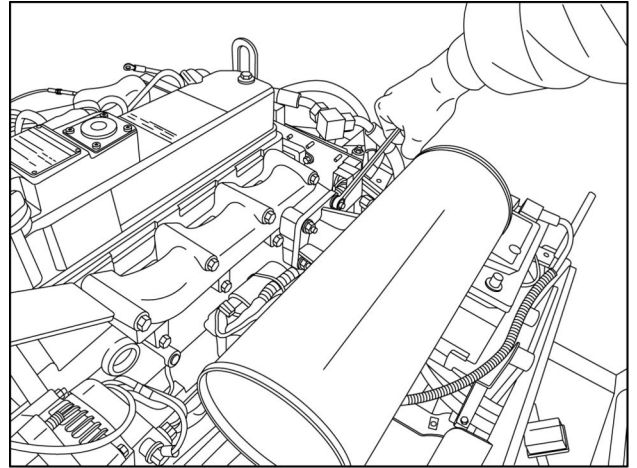

RAIL13SSL0069BA 4

10. Disconnect the battery wire **(1)** on the alternator.
11. Disconnect the regulator connector **(2)** on the alternator.
12. Disconnect the starter ignition wire **(3)**.
13. Disconnect the battery cable **(4)** on the starter.
14. Disconnect the ground cable **(5)**.

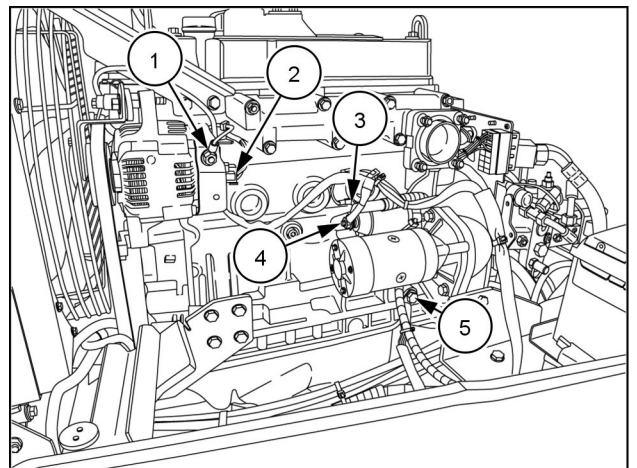

RAIL13SSL0048BA 5

15. Disconnect the intake snorkel **(1)**.
16. Disconnect the air box snorkel **(2)**.

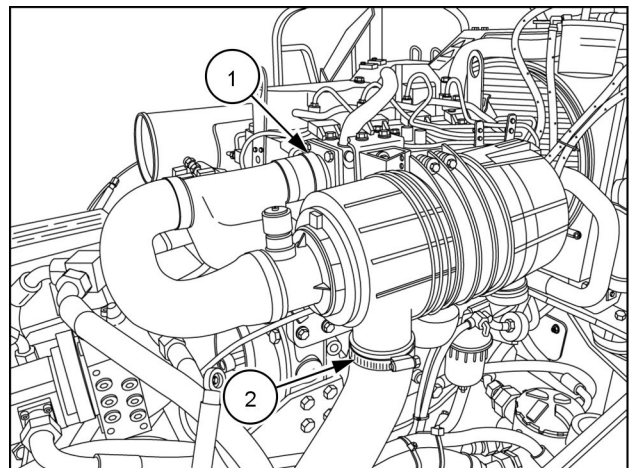

RAIL13SSL0059BA 6

17. Record the position of the throttle cable. Loosen the jam nut **(1)**, and slide the throttle cable away from the mounting bracket.

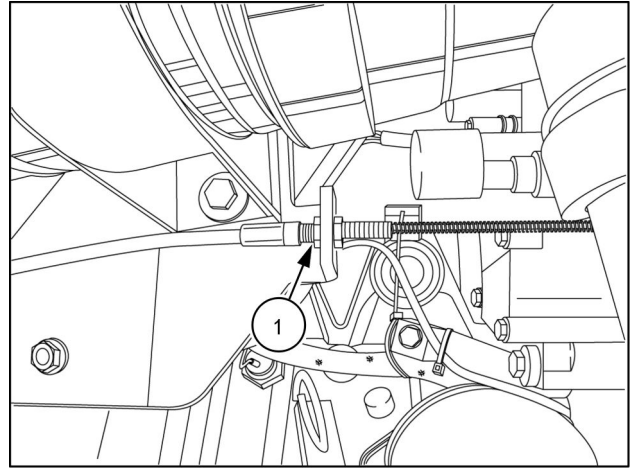

RAIL13SSL0058BA 7

18. Remove the air box.

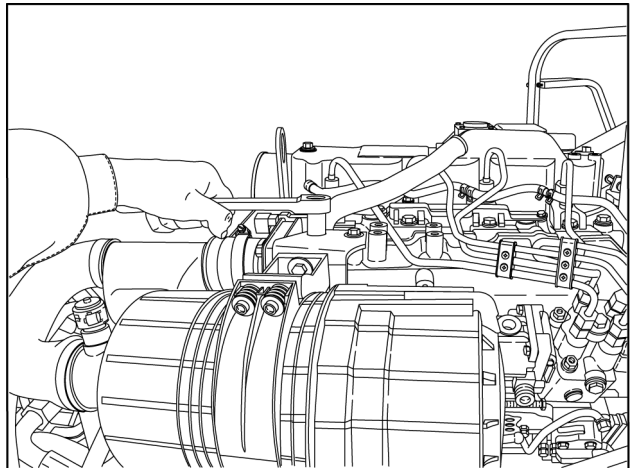

RAIL13SSL0057BA 8

19. Disconnect the glow plug wire **(1)**.

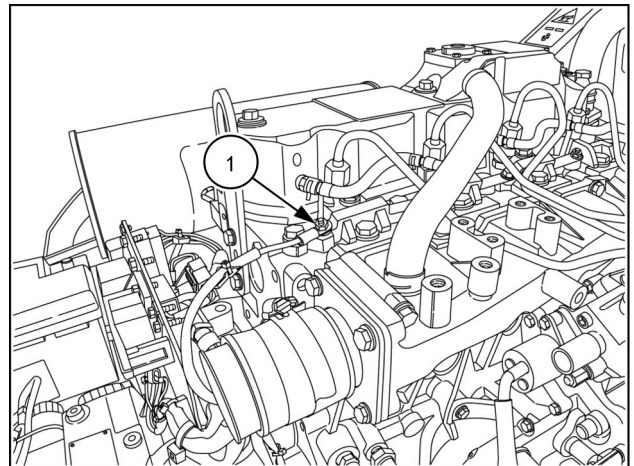

RAIL13SSL0071BA 9

20. Disconnect and cap the fuel feed hose (1).
21. Disconnect and cap the drain hose (2) for the oil pan.

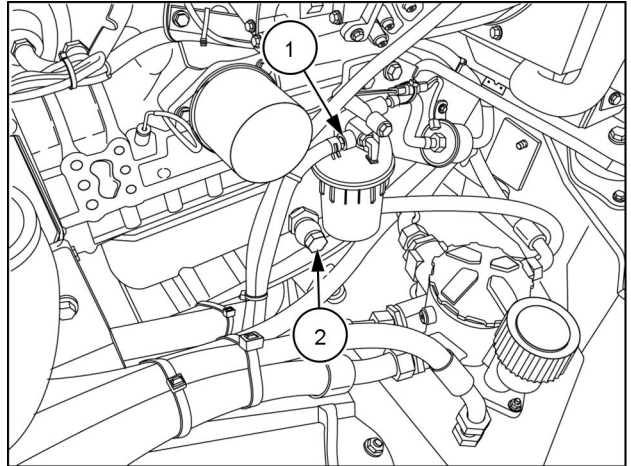

RAIL13SSL0074BA 10

22. Disconnect the electrical connector (1) for the injection pump solenoid.
23. Disconnect the wire (2) for the oil pressure sender.
24. Disconnect the throttle cable (3).
25. Disconnect the electrical connector (4) for the fuel pump.

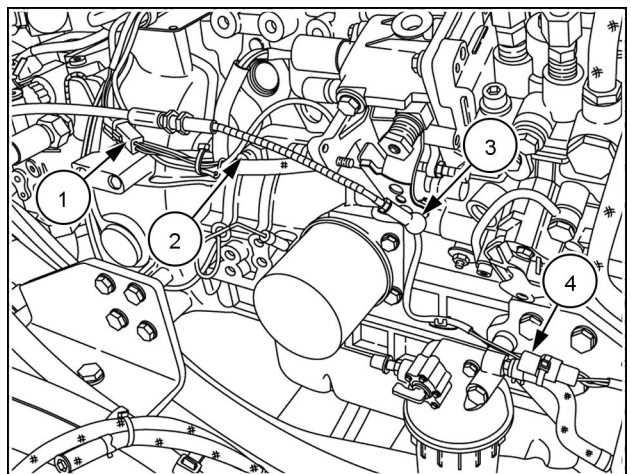

RAPH13SSL0191BA 11

26. Disconnect the wire (1) on the coolant temperature sensor.

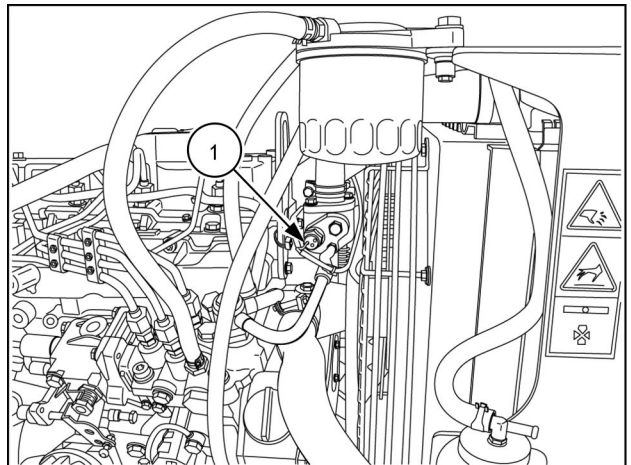

RAIL13SSL0068BA 12

27. Disconnect and cap the fuel return line (1).

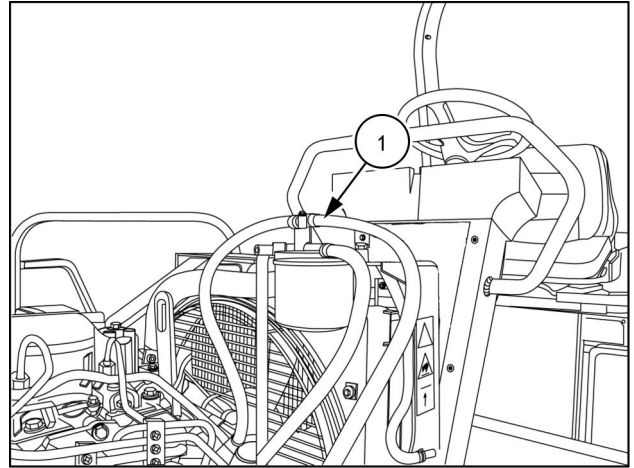

RAIL13SSL0056BA 13

28. Remove the P-clamps (1) that retain the engine harness.

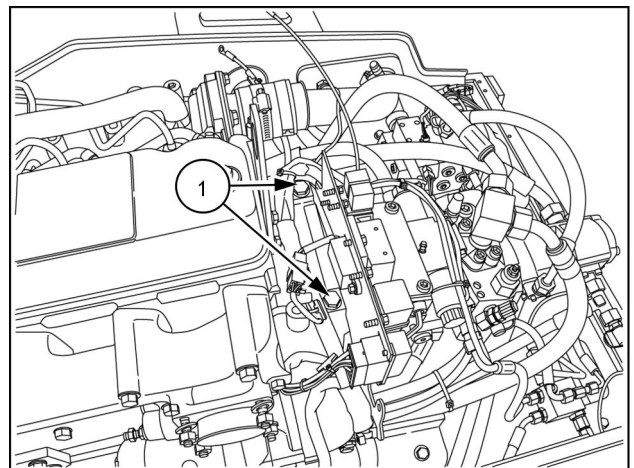

RAIL13SSL0066BA 14

29. Install suitable lifting equipment (1) to the engine and pump assembly.

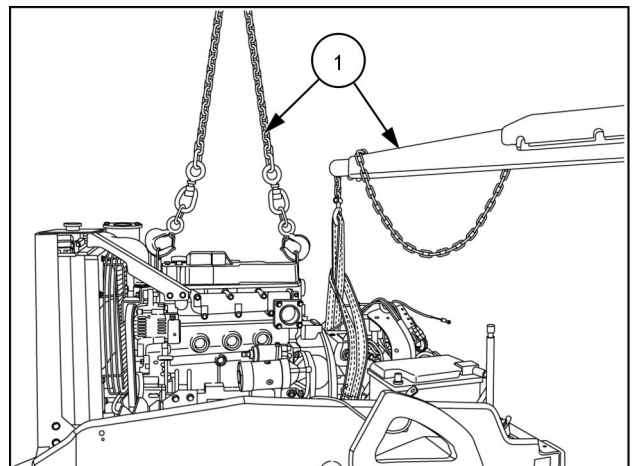

RAIL13SSL0043BA 15

30. Remove the bell housing bolts.

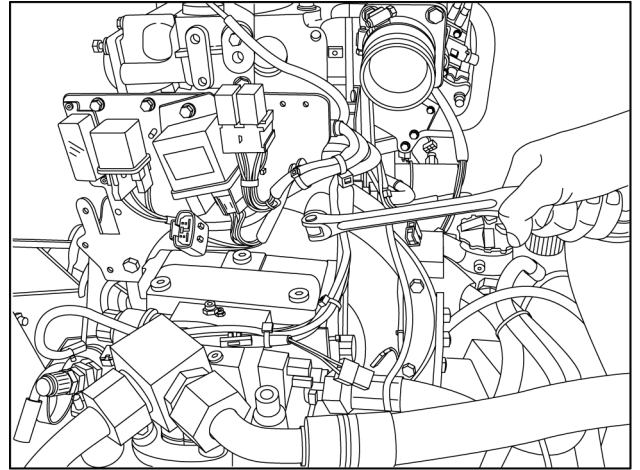

RAIL13SSL0046BA 16

31. Remove the engine mount bolts (1).

32. Repeat step 31 on the other side.

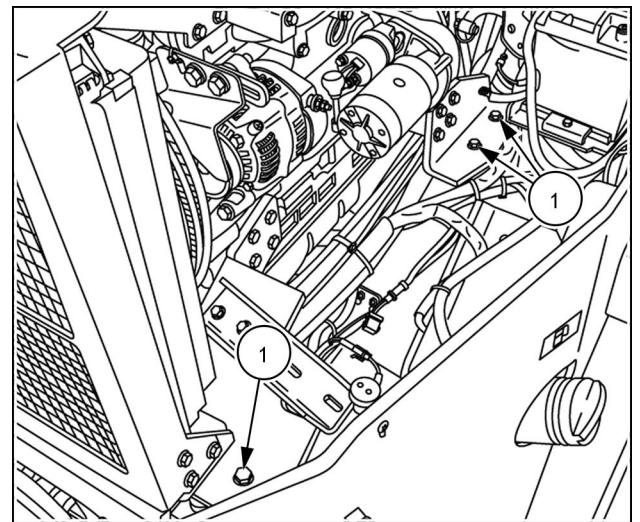

RAPH13SSL0193BA 17

33. Remove the engine.

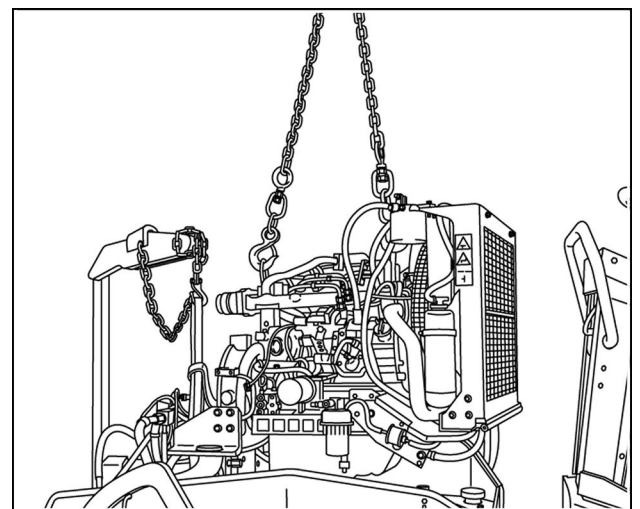

RAPH13SSL0194BA 18

Engine - Install

⚠ DANGER

Heavy objects!

Lift and handle all heavy components using lifting equipment with adequate capacity. Always support units or parts with suitable slings or hooks. Make sure the work area is clear of all bystanders. Failure to comply will result in death or serious injury.

D0076A

1. Slowly lower the engine into the engine compartment.

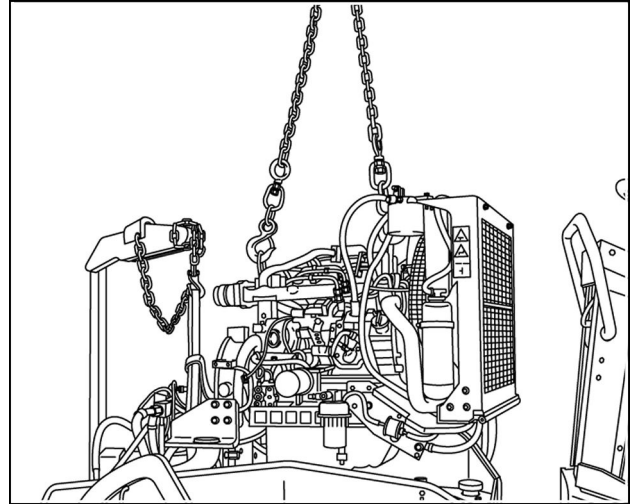

RAPH13SSL0194BA 1

2. Apply **LOCTITE® 242®** to the engine mount bolts (1). Install the engine mount bolts (1). Torque the engine mount bolts (1) to **84 N·m (62 lb ft)**.
3. Repeat step 2 on the other side.

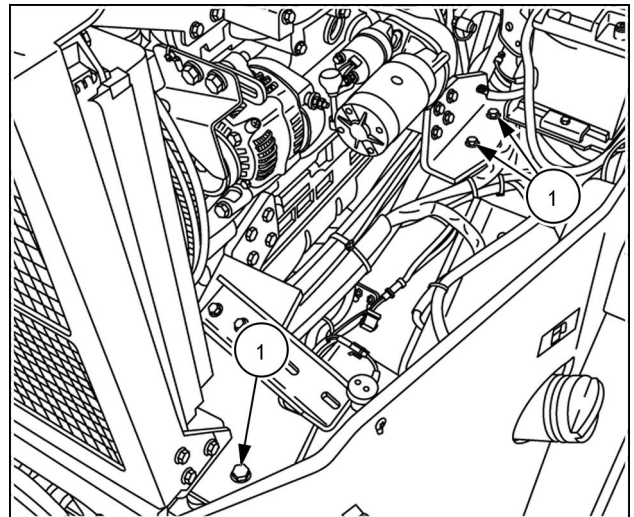

RAPH13SSL0193BA 2

4. Apply **LOCTITE® 242®** to the bell housing bolts. Install the bell housing bolts. Torque the bell housing bolts to **48 N·m (35 lb ft)**.

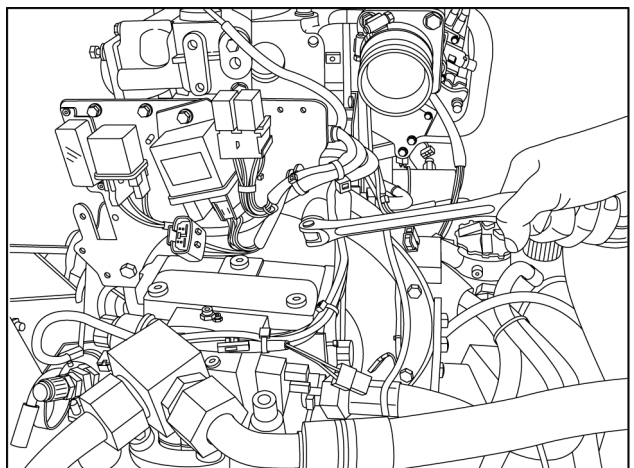

RAIL13SSL0046BA 3

5. Remove the lifting equipment **(1)** on the engine and pump assembly.

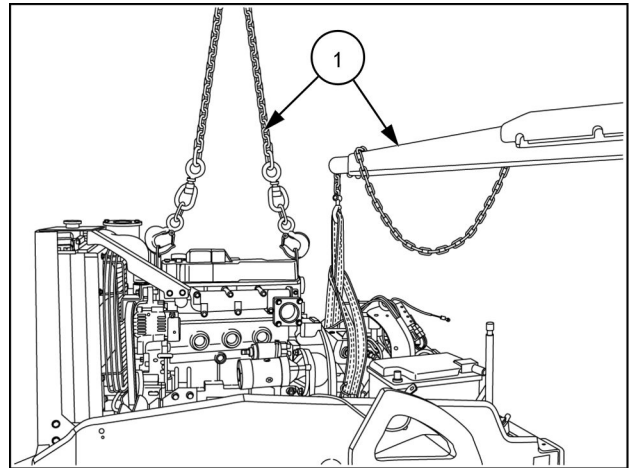

RAIL13SSL0043BA 4

6. Route the engine harness through the P-clamps, and install the P-clamps **(1)** to the engine block.

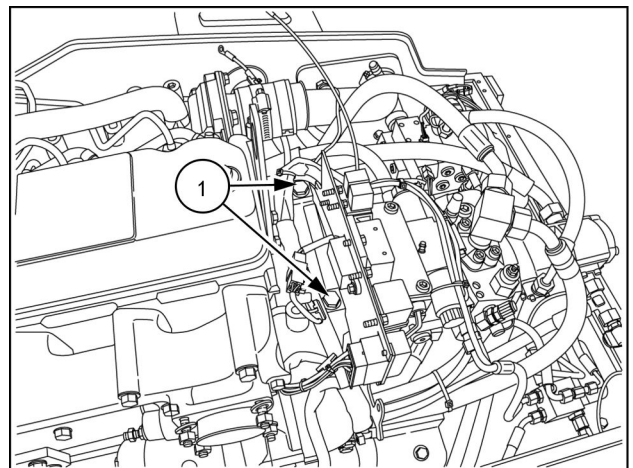

RAIL13SSL0066BA 5

7. Connect the fuel return line **(1)** to the fuel filter housing.

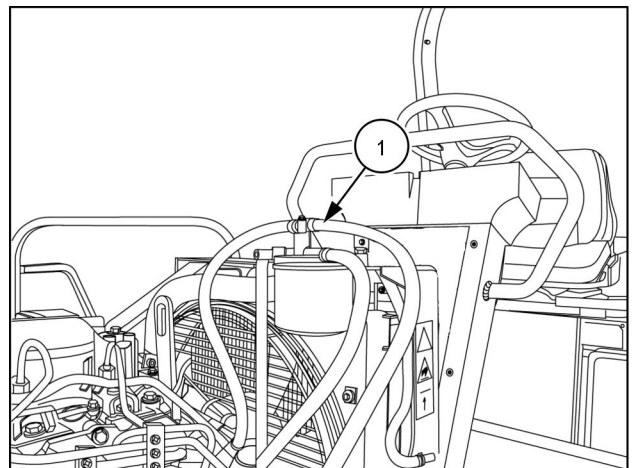

RAIL13SSL0056BA 6

8. Connect the wire **(1)** to the coolant temperature sensor.

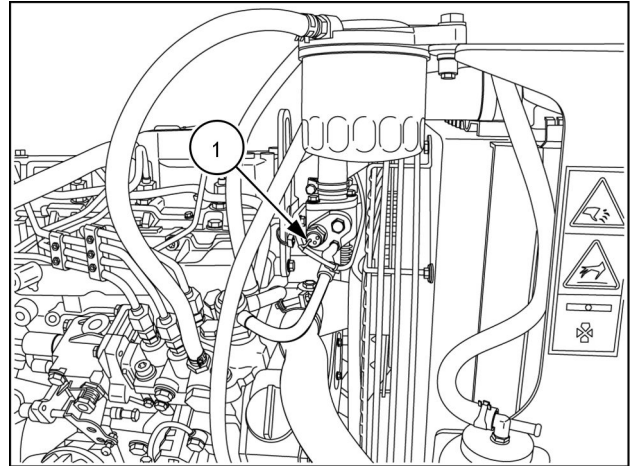

RAIL13SSL0068BA 7

9. Connect the electrical connector **(1)** for the injection pump solenoid.
10. Connect the wire **(2)** for the oil pressure sender.
11. Connect the throttle cable **(3)**.
12. Connect the electrical connector **(4)** for the fuel pump.

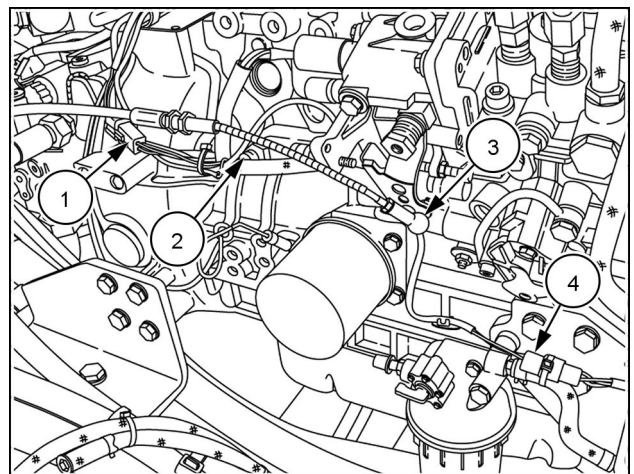

RAPH13SSL0191BA 8

13. Connect the fuel feed hose **(1)** to the water separator.
14. Connect the drain hose **(2)** for the oil pan.

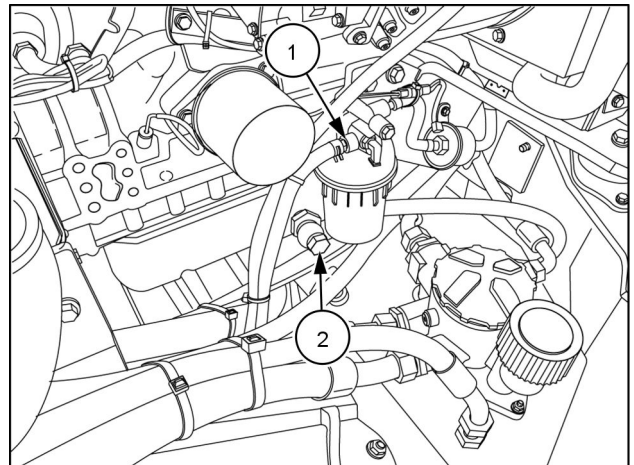

RAIL13SSL0074BA 9



Suggest:

If the above button click is invalid.

Please download this document

first, and then click the above link

to download the complete manual.

Thank you so much for reading

15. Connect the glow plug wire (1).

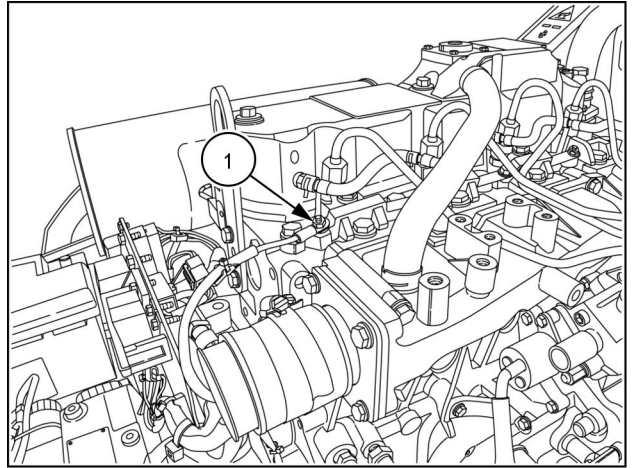

RAIL13SSL0071BA 10

16. Install the air box.

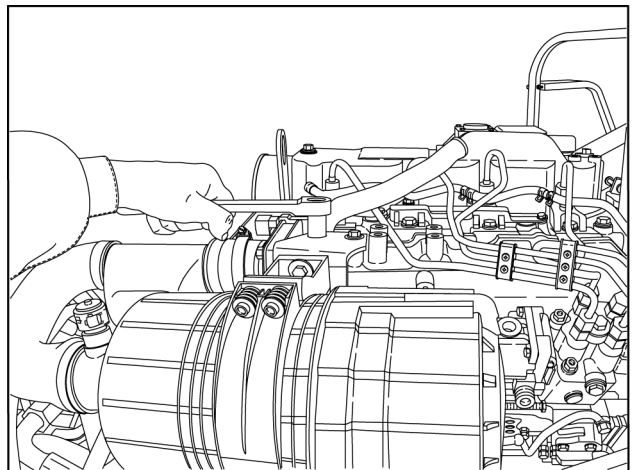

RAIL13SSL0057BA 11

17. Slide the throttle cable into the mounting bracket. Verify that your previous marking on the throttle cable is in the correct position. Tighten the jam nut (1).

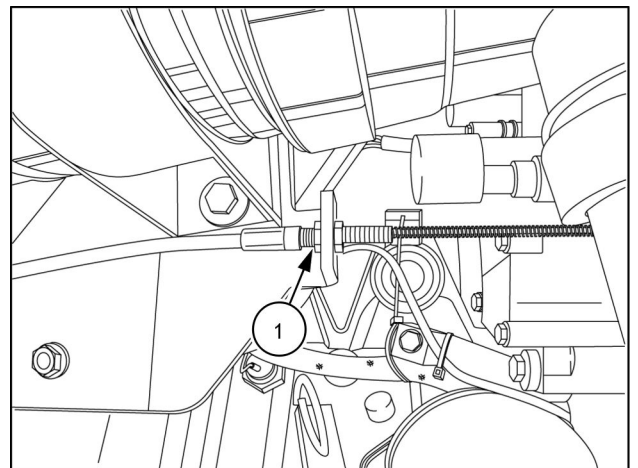

RAIL13SSL0058BA 12

<https://www.ebooklibonline.com>

Hello dear friend!

Thank you very much for reading.

Enter the link into your browser.

The full manual is available for immediate download.

<https://www.ebooklibonline.com>