

1822, 1844, 2022, 2044 and 2055 Cotton Picker
Service Manual

Table of Contents

	Description	Section No.	Form No.
General		Tab 1	
	Loctite Product Chart		8-98900
	Engine Specifications - D466	1020	8-62491
Engines - D466 Navistor (International)		Tab 2	
	Engine Troubleshooting	2010	8-62231
	Engine Tune-Up - D466	2015	8-27421
	Engine Removal and Installation	2020	8-62190
	Cylinder Head and Valve Train	2030	8-27181
	Cylinder Block	2040	8-27211
	Lubrication System	2060	8-27191
	Turbocharger - T04B	2265	8-20190
	Turbocharger Failure Analysis - All Engines	2565	9-78235
	Cooling System	2070	8-27231
	Air Induction and Exhaust System	2090	8-62510
- 6-590 Case			
	Engine Specifications - 6-590	2401	8-26063
	Cylinder Head and Valve Train	2415	8-26073
	Cylinder Block	2425	8-26084
	Lubrication System	2445	8-26093
	After Cooler	2545	8-26120
	Cooling System	2455	8-26103
	Turbocharger 2465		8-26110
- 6-830 Case			
	Engine Specifications	2403	8-28423
	Cylinder Head and Valve Train	2415	8-28432
	Cylinder Block	2425	8-28442
	Lubrication System	2445	8-28452
	Cooling System	2455	8-28462
	Turbocharger	2465	8-28470
Fuel System - D466 Navistor Engines		Tab 3	
	Fuel System and Filters	3010	8-27241
	Fuel Injection Pump - Robert Bosch Type MW	3020	8-27251
	Fuel Injectors	3030	8-27261
- 6-590 Case Engine			
	Fuel System and Filters	3410	8-26131
	Fuel Injection Pump (CAV)	3411	8-97711
	Fuel Injectors	3413	8-26152
- 6-830 Case Engine			
	Fuel System and Filters	3410	8-28480
	Fuel Injection Pump	3412	8-28492
	Fuel Injectors	3413	8-28501

Reprinted

1822, 1844, 2022, 2044 and 2055 Cotton Picker
Service Manual

Table of Contents

Description	Section No.	Form No.
Electrical	Tab 4	
Electrical Wiring Schematics and Troubleshooting - 2022 & 2044	4001	8-97551
Electrical Wiring Schematics and Troubleshooting - 2055	4002	8-98001
Electrical System Troubleshooting - 1822 & 1844	4010	8-62030
Alternator - Bosch	4004	8-91792
Instrument Cluster Troubleshooting	4011	8-62520
Starting Motor - Nippondensa	4011	8-95970
Digital Tachometer Troubleshooting	4012	8-62040
Compactor Troubleshooting	4013	8-62050
Monitor Troubleshooting	4014	8-62061
Cotton Picker Electrical Wiring Diagram - 1822 & 1844	4020	8-62070
Cab Electrical Wiring Diagram - 1822 & 1844	4025	8-62360
Electro-Hydraulic Valve Wiring Diagram - 1822 & 1844	4030	8-62080
Battery Servicing and Testing	4235	8-20291
Starter Motor - 1822 & 1844	4040	8-62530
Alternator System - Motorola	4060	8-62170
Neutral Start Switches	4070	8-62271
Steering	Tab 5	
Steering Axle - 2055	5003	8-99060
Steering System Testing	5010	8-62420
Steering Column and Hand Pump - Ross	5020	8-62430
Steering Column and Hand Pump - Eaton	5021	8-98040
Steering Cylinder	5030	8-62440
Steering Axle -1822, 1844, 2022 & 2044	5040	8-62450
Power Train	Tab 6	
Hydrostatic Propulsion Troubleshooting	6010	8-62380
Foot-N-Inch Valve	6015	8-62550
Hydrostatic Drive Pump Removal and Installation	6017	8-62280
Hydrostatic Drive Pump	6018	7-34820
Hydrostatic Drive Motor	6030	8-62471
Transmission and Drum Drive Assembly, Removal and Installation	6035	8-62250
Transmission - 1822, 1844, 2022 & 2044	6040	8-62391
Transmission - 2055	6041	8-99050
Drum Drive Assembly - 1822, 1844, 2022 & 2044	6050	8-62091
Drum Drive Assembly - 2055	6051	8-82770
Final Drive and Pinion Assembly	6060	8-62201
Brakes	Tab 7	
Service and Parking Brake -1822, 1844, 2022 & 2044	7010	8-62211
Service and Parking Brake - 2055	7011	8-99120
Brake Valve and Cylinders	7020	8-62240

1822, 1844, 2022, 2044 and 2055 Cotton Picker
Service Manual

Table of Contents

Description	Section No.	Form No.
Hydraulic		
Tab 8		
Hydraulic System Schematics and Troubleshooting - 2022 & 2044	8001	8-97560
Hydraulic System Schematics and Troubleshooting - 2055	8002	8-98010
Hydraulic System Troubleshooting - 1822 & 1844	8010	8-62100
Hydraulic System Testing - 1822 & 1844	8020	8-62620
Hydraulic Oil Filters	8030	8-62261
Hydraulic Pump Removal and Installation	8037	8-62290
Hydraulic Pump and Compensator	8040	8-62480
Electro-Hydraulic Valves	8050	8-62111
Electro-Hydraulic Manifold Valve - 2055	8051	8-99020
Hydraulic Valves, Cylinders and Motor	8060	8-62181
Destroke Solenoid Valve	8061	8-98770
Height Control Valves and Cylinders - 2055 Model	8062	8-99110
Accessories		
Tab 9		
Servicing the Air Conditioner Compressor Sanden Model SD 508 HD	9000	7-35200
Air Conditioner Troubleshooting	9001	7-35210
Air Conditioner System Gauges and Testing	9002	7-37680
Air Conditioner System Service, Recovery, Evacuation and Recharging	9003	7-34860
Air Conditioning Components Service for Systems with Sanden Compressor	9004	7-34890
Air Conditioner Compressor Removal and Installation on Navistar Engines	9030	8-62331
Servicing the York Air Conditioner Compressor and System Components	9040	8-62320
Servicing the Cab Blower	9050	8-62300
Operators Seat	9060	8-62310
Fan Assembly	9070	8-62221
Moistener System	9075	8-62571
Basket Assembly	9077	8-62580
Picker Drum Removal and Installation	9080	8-62120
Picker Drum Removal and Installation - 2055 Model	9081	8-99190
Chain Driven Picker Drum Service	9090	8-62130
Gear Driven Picker Drum Service	9091	8-97850
Picker Bar and Spindle Lubrication System	9092	8-98610
Drum Gearboxes and Input Drive Shafts - 2055 Model	9093	8-99100
How It Works		
Tab 10		
Digital Tachometer	10030	8-62400
Compactor Control	10050	8-62630
Drum Operation	10070	8-62140

<https://www.ebooklibonline.com>

Hello dear friend!

Thank you very much for reading.

Enter the link into your browser.

The full manual is available for immediate download.

<https://www.ebooklibonline.com>

SPECIAL TOOLS

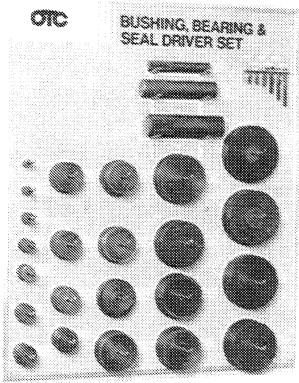

CAS-10387 BUSHING BEARING AND SEAL DRIVER SET



CAS-10389 UNIVERSAL DRIVER SET
(3-1/16 TO 4-1/2 INCH DIAMETER)



CAS-10388 UNIVERSAL DRIVER SET
(1/2 TO 4-1/2 INCH DIAMETER)

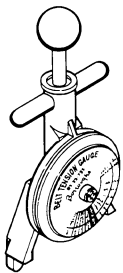

BELT TENSION GAUGE

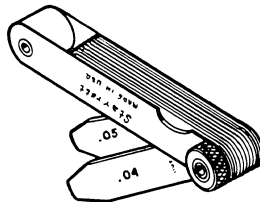

FEELER GAUGE

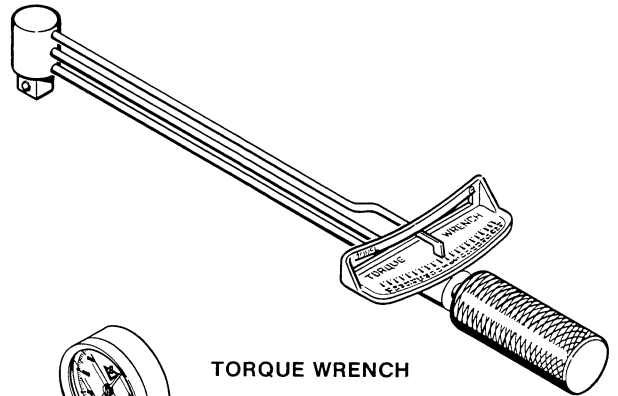

TORQUE WRENCH

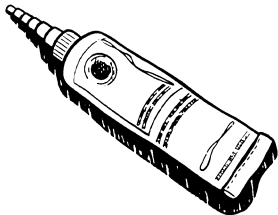

RTV LIQUID GASKET
(CASE PART NUMBER 345-61)



BLACK PERMATEX NUMBER 2
CASE PART NUMBER M20458

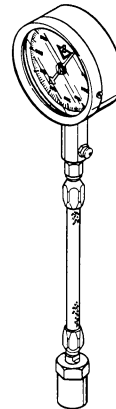

COMPRESSION GAUGE (FES-13-1)

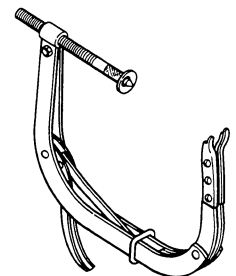

VALVE SPRING COMPRESSOR (CAS-1747)

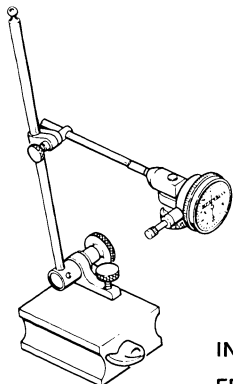

DIAL INDICATOR



INSTALLATION TOOL FOR CRANKSHAFT FRONT WEAR SLEEVE (IH-04-3004)

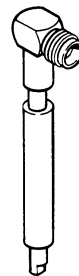

COMPRESSION TEST ADAPTER (FES-14-16)

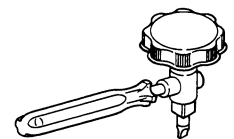

TAPPET ADJUSTMENT TOOL

SPECIFICATIONS

	U.S. Value	Metric Value
Maximum Crankshaft Damper Pulley Cavity Depth	0.12 inch	3.00 mm
Timing Marks On The Crankshaft Pulley Hub And Inertia Member Of The Damper Must Be Aligned Within	0.060 inch	1.524 mm
Run-Out On Front Face Of The Damper Inertia Member	0.060 inch	1.524 mm
Rocker Arm To Valve Clearance:		
Intake Valves (Cold)	0.025 inch	0.635 mm
Exhaust Valves (Cold)	0.025 inch	0.635 mm
Engine Compression	335 to 365 PSI	2 310 to 2 517 kPa (23.10 to 25.17 bar)
Maximum Opening Pressure Variation Between Each Cylinder	150 PSI	1 034 kPa (10.34 bar)
Fuel Injection Pump Static Timing		
DT-466C (1844 Cotton Picker)	25 degrees BTC	
D-466 (1640 Combine)	12 degrees BTC	
DT-466B (1660 Combine)	15 degrees BTC	
DTI-466C (1680 Combine)	25 degrees BTC	
Fan Belt Deflection (Cooling System) From:		
A 25 lb (111 N) Force	(1844 Cotton Picker) 13/16 inch (1640, 1660 and 1680 Combine) 1/2 inch	21 mm 13 mm
A Belt Tension Gauge	60 to 85 lbs	267 to 378 N
Compressor Belt Deflection (Air Conditioner) From:		
A 25 lb (111 N) Force	(1844 Cotton Picker) 15/32 inch (1640, 1660 and 1680 Combine) 1/2 inch	11.9 mm 13 mm
A Belt Tension Gauge	60 to 85 lbs	267 to 378 N
Low Idle Engine RPM	*950 to 1050 RPM	
High Idle Engine RPM	*2690 to 2770 RPM	
Rated Load Engine RPM	*2500 RPM	
Overload Engine RPM	*2000 RPM	

* Speeds are after engine is operated for 15 minutes minimum.

SPECIAL TORQUES

	U.S. Value	Metric Value
Oil Pump Housing Bolts	24 to 29 lb ft	33 to 39 Nm (3.3 to 3.9 kgm)
Crankshaft Pulley Bolts	110 to 132 lb ft	149 to 172 Nm (14.9 to 17.2 kgm)
Crankshaft Pulley Seal Plate Bolts	45 to 54 lb ft	61 to 73 Nm (6.1 to 7.3 kgm)
Cylinder Head Bolts	165 lb ft	225 Nm (22.5 kgm)
Valve Cover Bolts	24 to 29 lb ft	33 to 39 Nm (3.3 to 3.9 kgm)
Injection Fuel Pump Drive Gear Access Cover	24 to 29 lb ft	33 to 39 Nm (3.3 to 3.9 kgm)

ENGINE TUNE-UP PROCEDURE

Checking The Crankshaft Damper Pulley

STEP 1

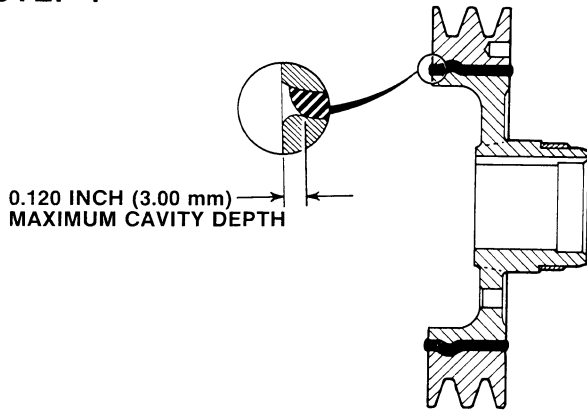

The damper must be replaced if the cavity depth in the inner or outer diameter of the rubber member is 0.120 inch (3.00 mm) or more through 360 degrees. The cavity in the rubber member is caused by rubber becoming loose and falling off.

STEP 2

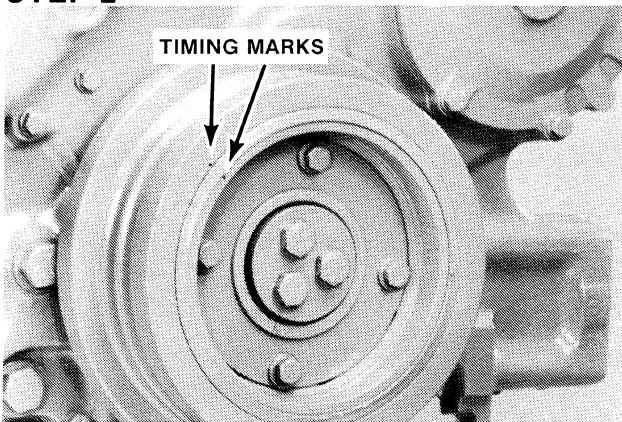

The timing marks on the hub and inertia member of the damper must be aligned within 0.060 inch (1.524 mm). Replace the damper if the timing marks are not aligned within 0.060 inch (1.524 mm).

STEP 3

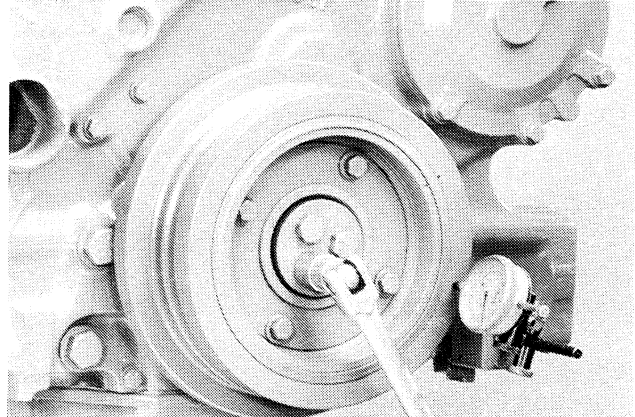

Use a dial indicator to measure the run-out on the front face of the inertia member. Measure the run-out at four different positions, 90 degrees apart. Replace the damper if the run-out is more than 0.060 inch (1.524 mm).

NOTE: Replace the damper if the inertia member of the damper touches the crankshaft pulley at any point.

STEP 4

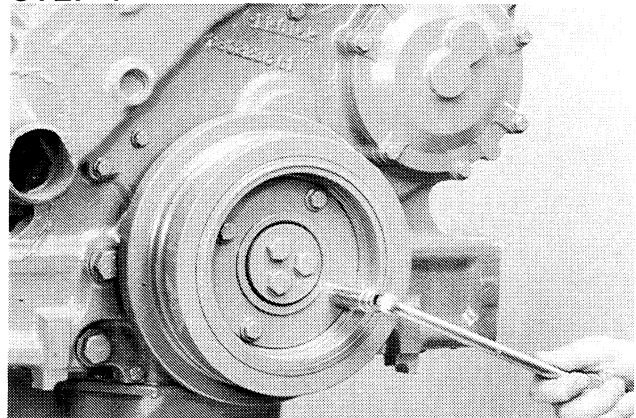

Remove the bolts from the seal plate that is on the engine vibration damper pulley.

STEP 5

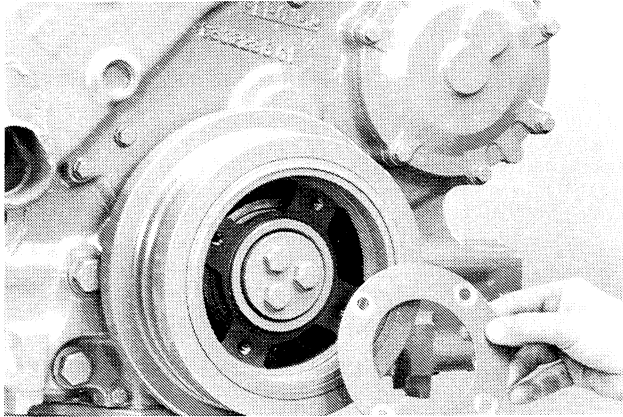

Remove the seal plate.

STEP 8

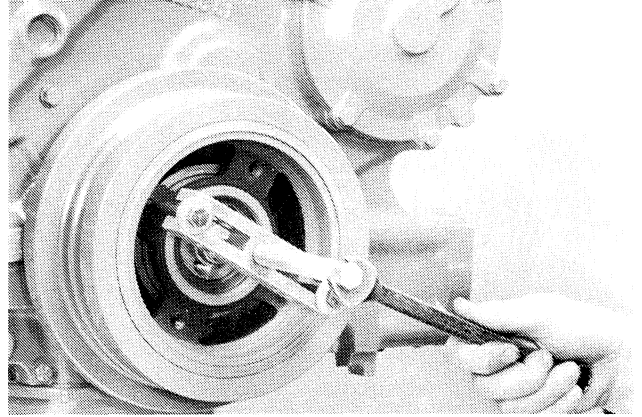

Use a suitable puller to remove the damper pulley.

STEP 6

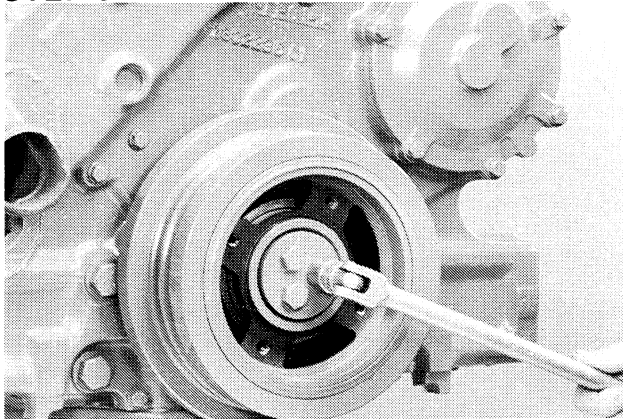

Remove the bolts from the damper retaining plate.

STEP 9

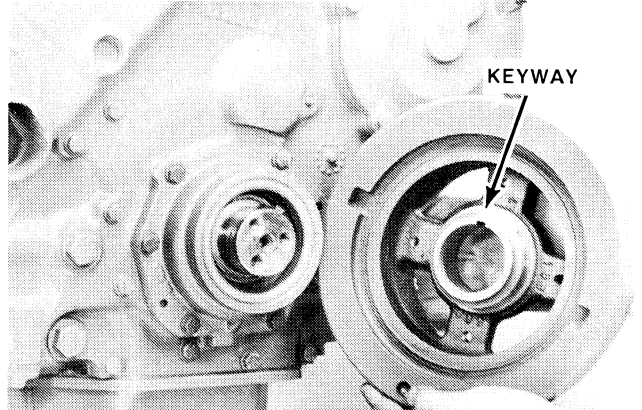

Inspect the keyway in the damper pulley to make certain that the hub is not cracked from pulley assembly over the key that is not correct. A crack in the hub will cause a distortion in the seal wear ring and a leak in the seal. Replace the damper if there are cracks in the hub.

STEP 7

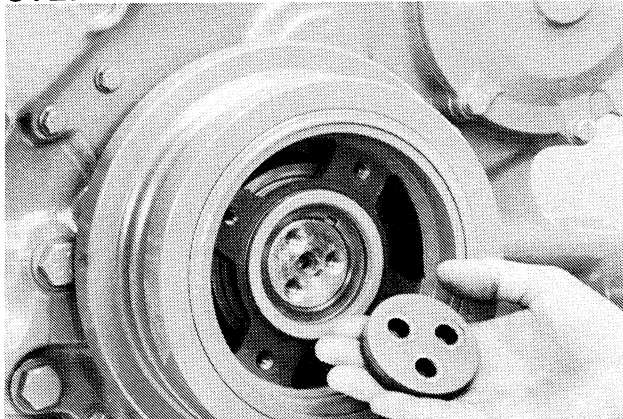

Remove the retaining plate.

STEP 10

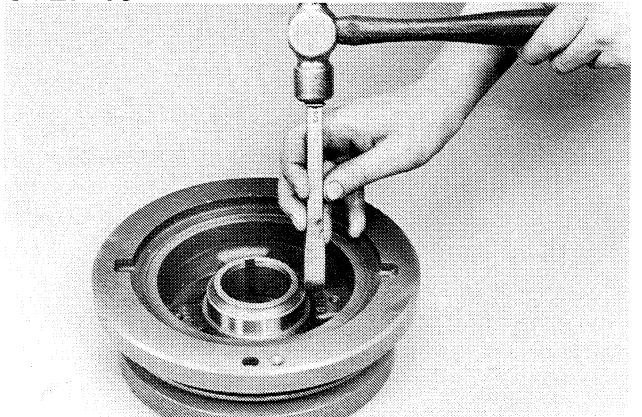

Remove the seal wear ring in the damper pulley if there are signs of distortion and scratches on the damper pulley. Use a chisel to cut through the wear ring. Be careful not to damage the damper hub.

STEP 11

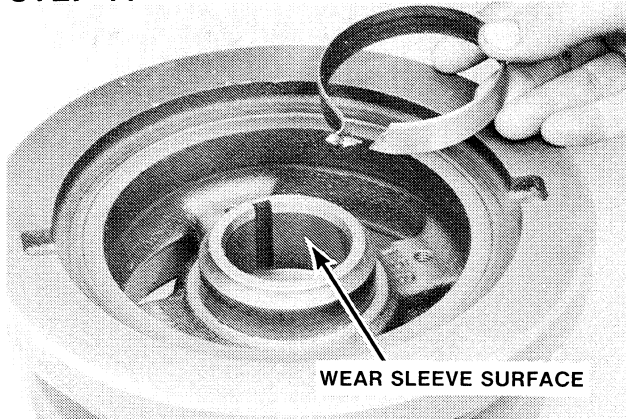

Remove the wear sleeve.

NOTE: Remove scratches from the wear sleeve surface of the hub.

STEP 12

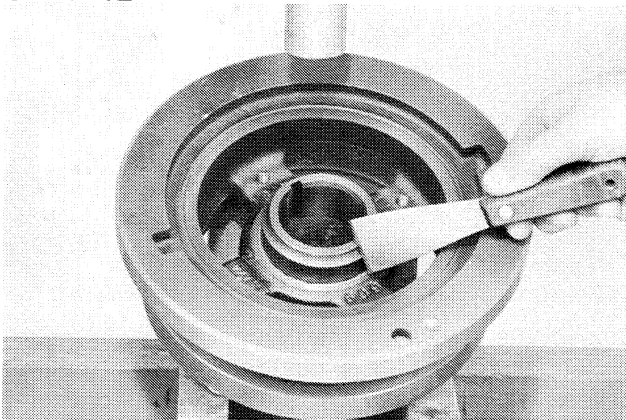

Remove all foreign material from the wear sleeve surface.

STEP 13

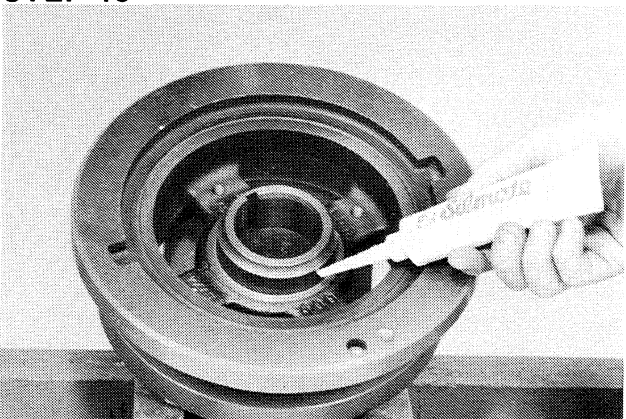

Apply a small bead of RTV liquid gasket (IH 446-839-C1)(Case 345-61) to the circumference of the wear sleeve contact area.

STEP 14

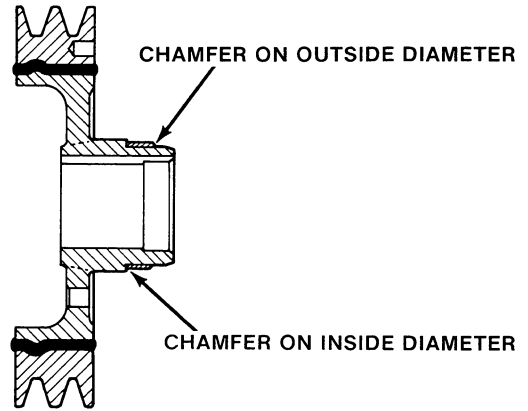

Position the new wear sleeve with the end having the chamfer on the inside diameter over the pulley hub. The end of the wear sleeve having the chamfer on the outside diameter must engage the installation tool.

STEP 15

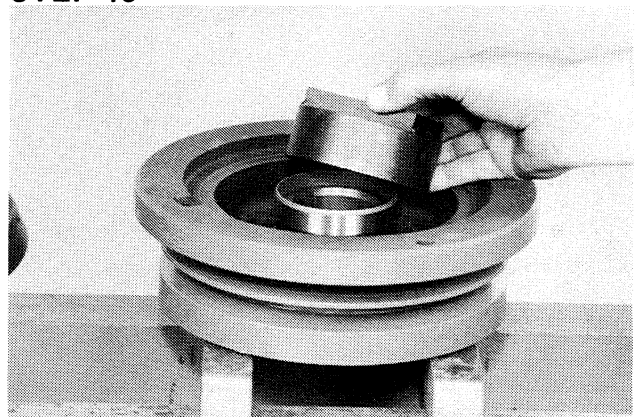

Install the wear sleeve installation tool (IH-04-3004) on the wear sleeve.

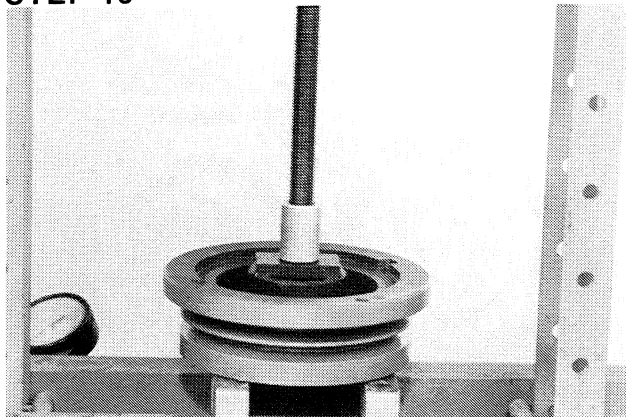
STEP 16

Press the wear sleeve on the hub until the sleeve hits the shoulder in the hub.

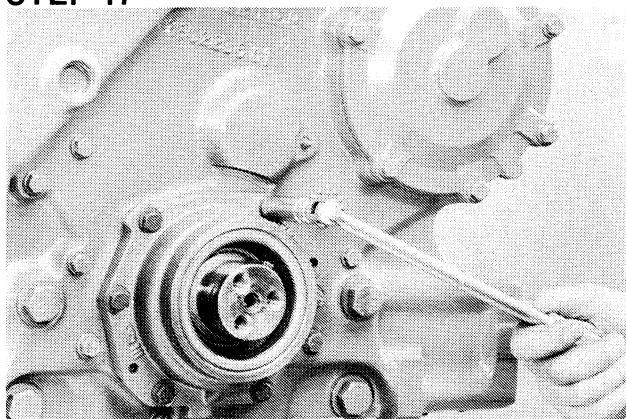
STEP 17

Remove the bolts from the lubricating oil pump housing.

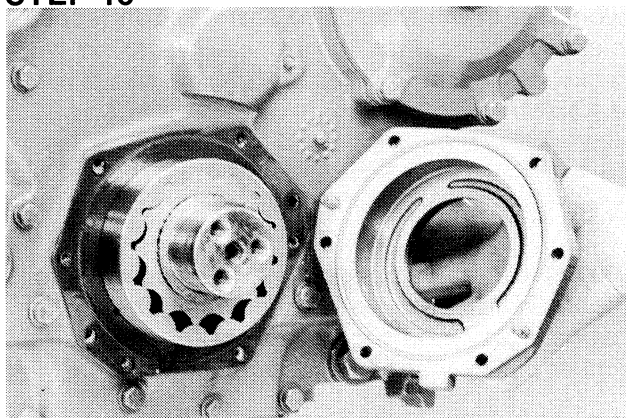
STEP 18

Remove the pump housing.

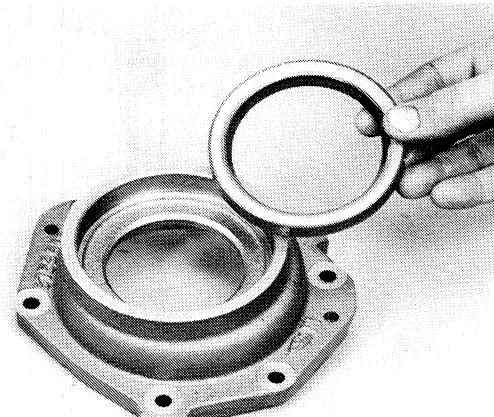
STEP 19

Remove the oil seal from the pump housing.

STEP 20

Install a new oil seal into the pump housing. Apply RTV liquid gasket (IH-446-839-C1)(Case 345-61) to the outside diameter of the oil seal. The lip of the oil seal must be toward the inside of the pump housing.

STEP 21

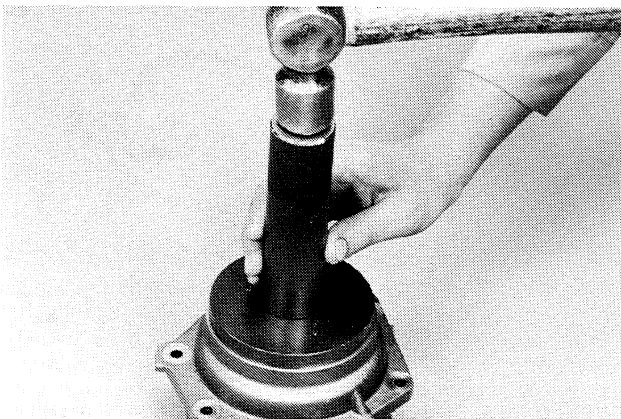
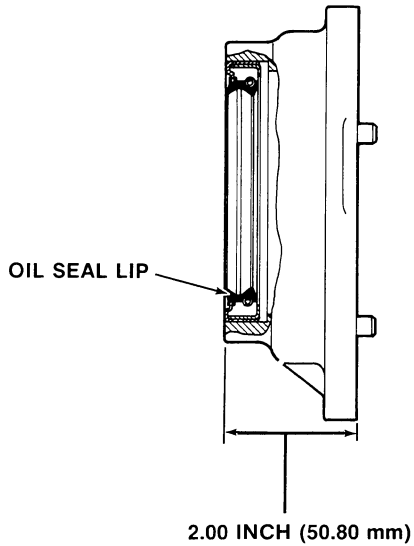

Use a driver (OTC-27553) and handle (OTC-27489) to press the oil seal into the pump housing to the dimension shown.

STEP 22

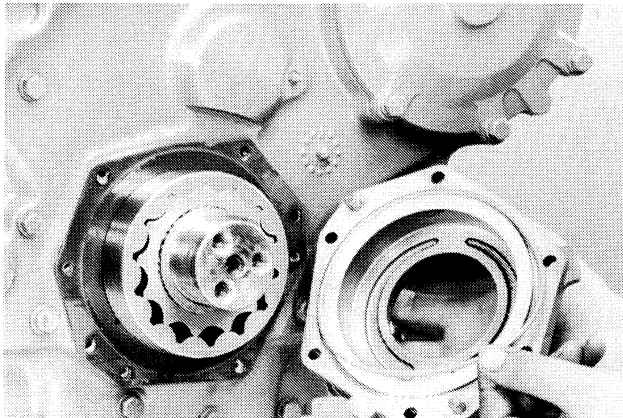

Install a new o-ring into the pump housing.

STEP 23

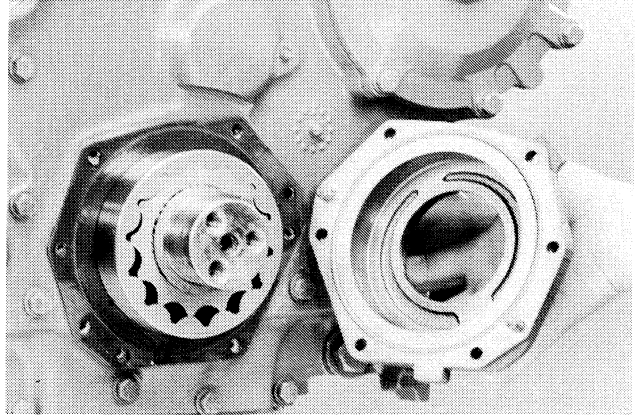

Install the pump housing to the front cover.

STEP 24

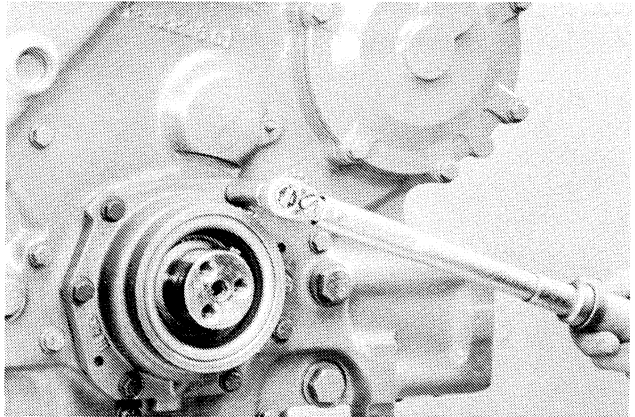

Install new bolts into the pump housing and tighten the bolts to a torque of 24 to 29 lb ft (33 to 39 Nm)(3.3 to 3.9 kgm).

NOTE: Be careful not to mix the six pump housing bolts with any other bolts. These six bolts have a nylon seal in the threads to seal through tapped holes which go into the oil cavity behind the crankcase front cover. Replace these six bolts with new bolts.

STEP 25

NOTE: Heat the damper pulley in boiling water for a period not to be more than one hour. The rubber member can be damaged. Do not try to install a damper pulley that has not been heated.

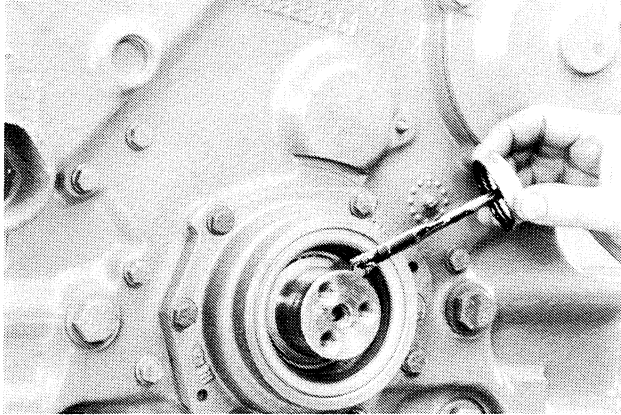

CAUTION Always wear heat protective gloves to prevent burning your hands when handling heated parts.

STEP 26

Apply a small amount of black Permatex Number 2 (Case Part Number M20458) to the key in the crankshaft and keyway in the damper hub.

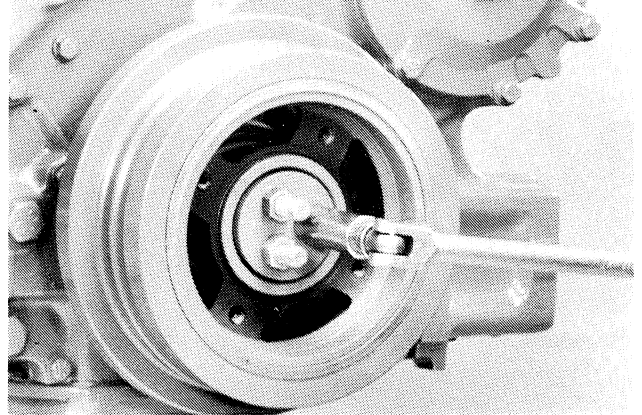
STEP 29

Install three studs through the retaining plate and into the crankshaft. Install nuts on the studs.

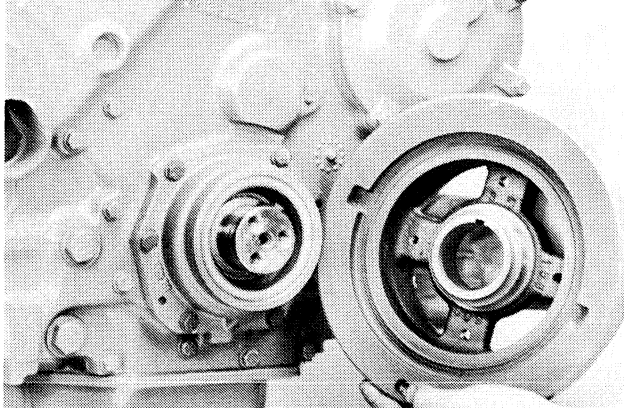
STEP 27

Install the damper pulley by aligning the key and keyway. Push the damper pulley on the crankshaft.

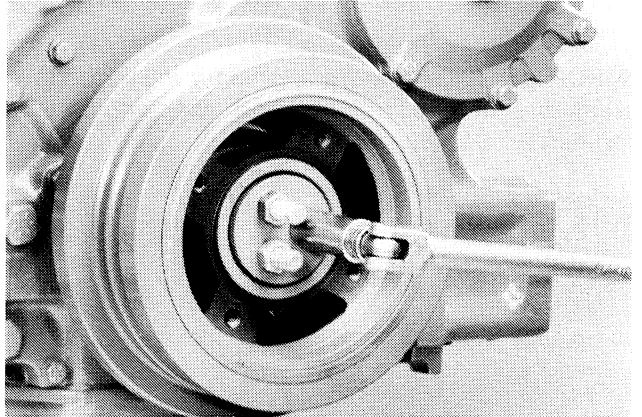
STEP 30

Tighten the nuts alternately to push the damper pulley on the crankshaft.

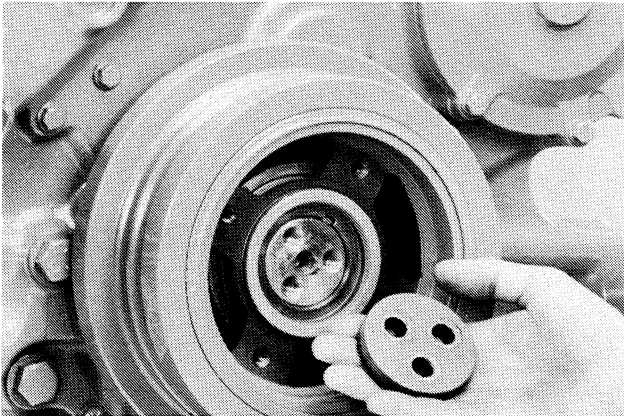
STEP 28

Install the damper pulley retaining plate into the damper pulley.

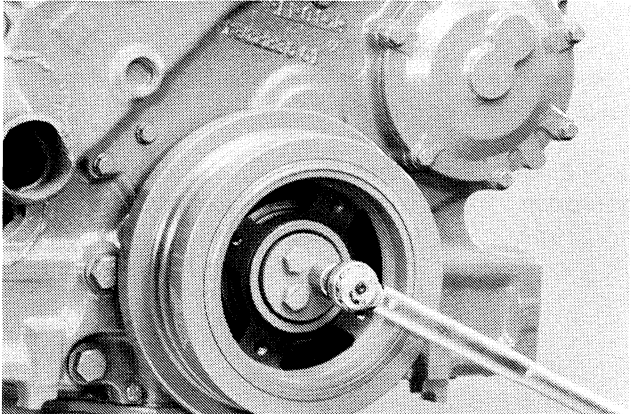
STEP 31

Remove the nuts and studs. Install the retaining plate bolts and tighten the bolts to a torque of 110 to 132 lb ft (149 to 179 Nm)(14.9 to 17.9 kgm). Prevent the engine from turning when tightening the bolts.

STEP 32

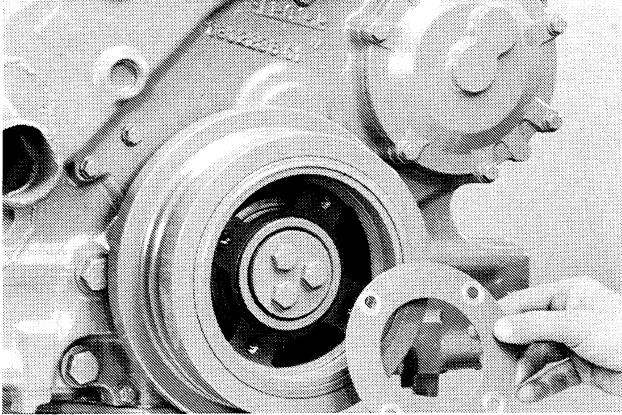

Install the seal plate.

STEP 33

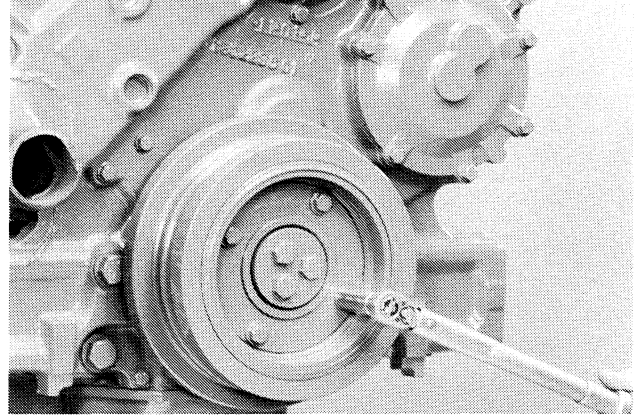

Install the seal plate bolts and tighten the bolts to a torque of 48 to 57 Nm (4.8 to 5.7 kgm) (35 to 42 lb ft).

Checking Piston Top Center

IMPORTANT: Check the alignment marks on the crankshaft damper pulley before checking piston top center. See Step 2.

STEP 34

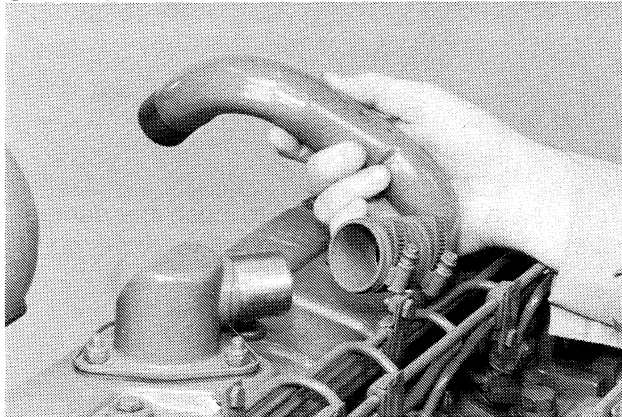

Remove the engine breather tube from the engine valve cover, if equipped.

NOTE: The turbocharger air cross over tube, if equipped, has been removed for photographic purposes.

STEP 35

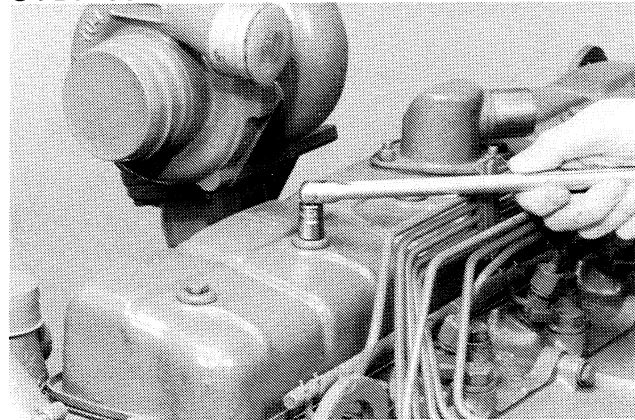

Remove the bolts from the valve cover.

STEP 36

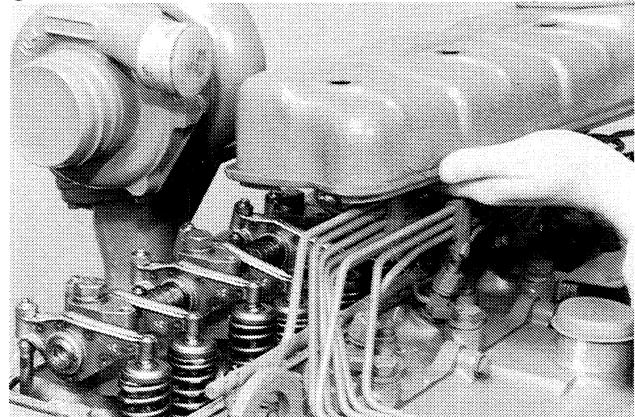

Remove the valve cover.



Suggest:

If the above button click is invalid.

Please download this document

first, and then click the above link

to download the complete manual.

Thank you so much for reading

STEP 37

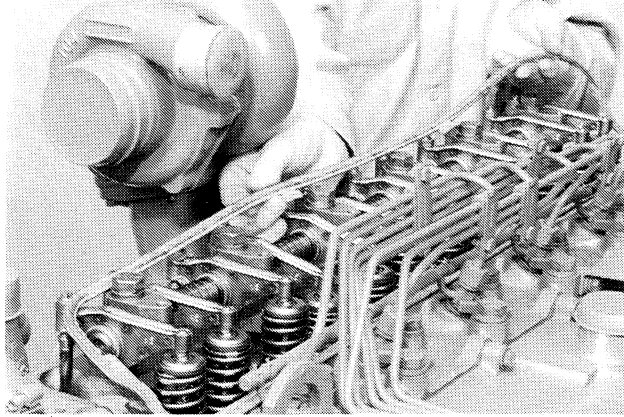

Remove the gasket.

STEP 40

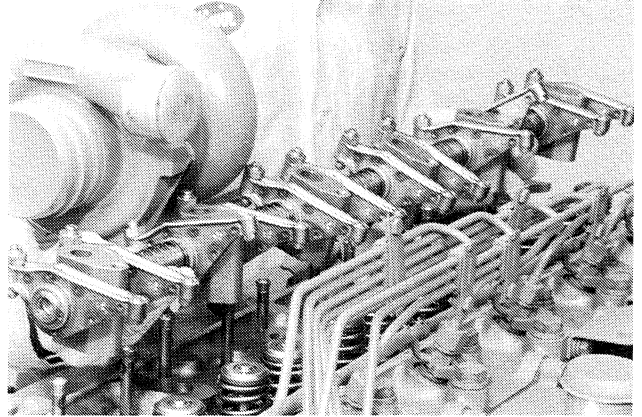

Remove the rocker arm assembly.

STEP 38

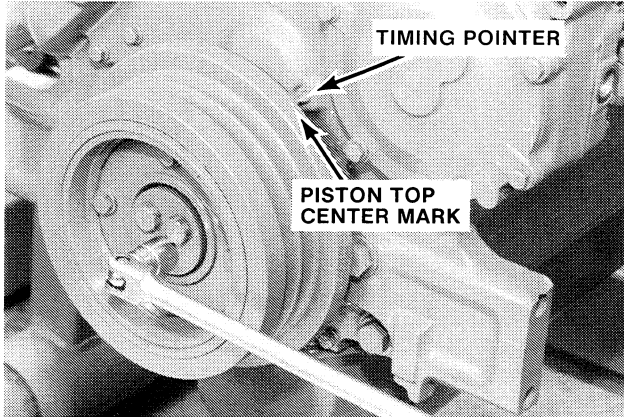

Turn the engine over until the piston top center mark on the crankshaft damper pulley is aligned with the timing pointer.

STEP 41

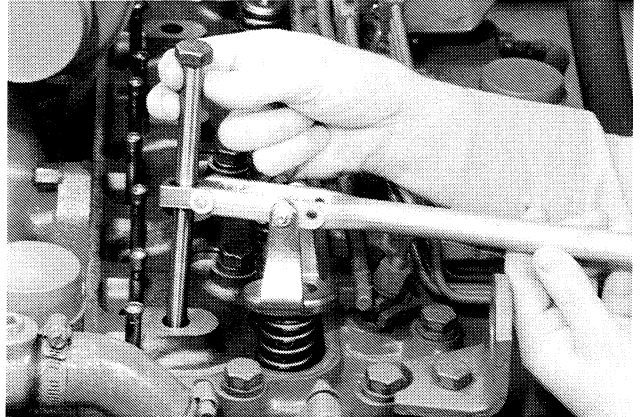

Use a spring compressor (CAS-1747) and one of the rocker arm assembly bolts to compress the number one intake valve spring.

STEP 39

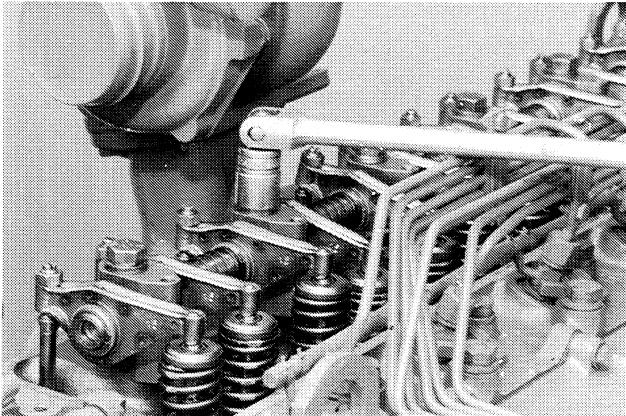

Remove the bolts from the rocker arm assembly.

STEP 42

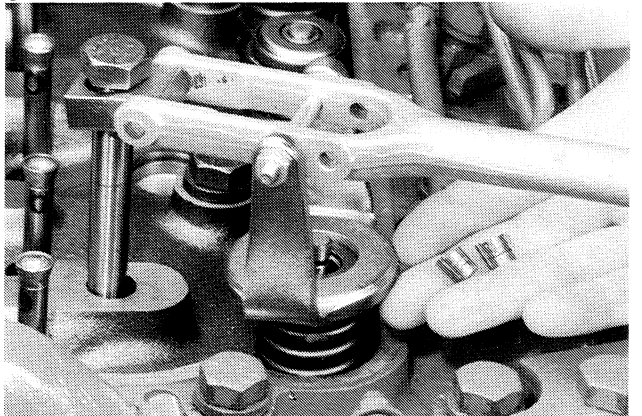

Compress the valve spring and remove the valve keepers.

<https://www.ebooklibonline.com>

Hello dear friend!

Thank you very much for reading.

Enter the link into your browser.

The full manual is available for immediate download.

<https://www.ebooklibonline.com>