

1107 DX
Soil Compactor

SERVICE MANUAL

Part number 47714442

1st edition English
October 2014



Contents

INTRODUCTION

Engine.....	10
[10.001] Engine and crankcase	10.1
[10.106] Valve drive and gears	10.2
[10.101] Cylinder heads	10.3
[10.105] Connecting rods and pistons.....	10.4
[10.103] Crankshaft and flywheel.....	10.5
[10.114] Pump drives	10.6
[10.218] Fuel injection system.....	10.7
[10.202] Air cleaners and lines	10.8
[10.250] Turbocharger and lines.....	10.9
[10.254] Intake and exhaust manifolds and muffler	10.10
[10.400] Engine cooling system	10.11
[10.310] Aftercooler.....	10.12
[10.304] Engine lubrication system.....	10.13
[10.408] Oil cooler and lines.....	10.14
[10.AAA] Engine generic sub-group	10.15
Rear axle system.....	27
[27.100] Powered rear axle.....	27.1
[27.106] Rear bevel gear set and differential	27.2
[27.120] Planetary and final drives	27.3
[27.124] Final drive hub, steering knuckles, and shafts	27.4
[27.AAA] Rear axle system generic sub-group.....	27.5
Hydrostatic drive.....	29
[29.218] Pump and motor components.....	29.1
Brakes and controls	33

[33.110] Parking brake or parking lock	33.1
Hydraulic systems.....	35
[35.000] Hydraulic systems.....	35.1
[35.300] Reservoir, cooler, and filters.....	35.2
Frames and ballasting	39
[39.100] Frame	39.1
[39.500] Vibratory roller.....	39.2
[39.AAA] Frames and ballasting generic sub-group.....	39.3
Steering.....	41
[41.101] Steering control	41.1
[41.200] Hydraulic control components.....	41.2
[41.206] Pump	41.3
[41.216] Cylinders	41.4
Wheels	44
[44.520] Rear wheels	44.1
Electrical systems	55
[55.000] Electrical system	55.1
[55.100] Harnesses and connectors.....	55.2
[55.201] Engine starting system	55.3
[55.301] Alternator.....	55.4
[55.302] Battery.....	55.5
Platform, cab, bodywork, and decals.....	90
[90.102] Engine shields, hood latches, and trims	90.1
[90.AAA] Platform, cab, bodywork, and decals generic sub-group.....	90.2

<https://www.ebooklibonline.com>

Hello dear friend!

Thank you very much for reading.

Enter the link into your browser.

The full manual is available for immediate download.

<https://www.ebooklibonline.com>



INTRODUCTION

Contents

INTRODUCTION

Safety rules	3
Safety rules	4
Safety rules - Ecology and the environment	5
Safety rules - Ductile iron	6
Safety rules	7
Basic instructions - Important notice regarding equipment servicing	8
Basic instructions – Shop and assembly	9
Torque - Minimum tightening torques for normal assembly	11
Torque - Standard torque data for hydraulics	16
Abbreviation – Measurements	18
Capacities	20

Safety rules

Personal safety





This is the safety alert symbol. It is used to alert you to potential personal injury hazards. Obey all safety messages that follow this symbol to avoid possible death or injury.

Throughout this manual you will find the signal words DANGER, WARNING, and CAUTION followed by special instructions. These precautions are intended for the personal safety of you and those working with you.

Read and understand all the safety messages in this manual before you operate or service the machine.

 DANGER indicates a hazardous situation that, if not avoided, will result in death or serious injury.

 WARNING indicates a hazardous situation that, if not avoided, could result in death or serious injury.

 CAUTION indicates a hazardous situation that, if not avoided, could result in minor or moderate injury.

FAILURE TO FOLLOW DANGER, WARNING, AND CAUTION MESSAGES COULD RESULT IN DEATH OR SERIOUS INJURY.

Machine safety

NOTICE: Notice indicates a situation that, if not avoided, could result in machine or property damage.

Throughout this manual you will find the signal word Notice followed by special instructions to prevent machine or property damage. The word Notice is used to address practices not related to personal safety.

Information

NOTE: Note indicates additional information that clarifies steps, procedures, or other information in this manual.

Throughout this manual you will find the word Note followed by additional information about a step, procedure, or other information in the manual. The word Note is not intended to address personal safety or property damage.

Safety rules

⚠ DANGER

Improper operation or service of this machine can result in an accident.
Do not operate this machine or perform any lubrication, maintenance, or repair on it until you have read and understood the operation, lubrication, maintenance, and repair information.
Failure to comply will result in death or serious injury.

D0010A

⚠ WARNING

Maintenance hazard!
Always perform all service procedures punctually at the intervals stated in this manual. This ensures optimum performance levels and maximum safety during machine operation.
Failure to comply could result in death or serious injury.

W0132A

NOTICE: *Extreme working and environmental conditions require shortened service intervals.*

Use Case fluids, lubricants, and filters for the best protection and performance of your machine. All fluids, lubricants, and filters must be disposed of in compliance with environmental standards and regulations. Contact your Dealer with any questions regarding the service and maintenance of this machine.

Use this manual with the operator's manual to understand and perform the complete service procedures. Read the safety decals and information decals on the machine. Read the Operator's Manual and safety manual. Understand the operation of the machine before you start any service.

Before you service the machine, put a "Do Not Operate" tag on the steering wheel or over the key switch. Ensure the tag is at a location where everyone who might operate or service the machine may see clearly.

Plastic and resin parts

- Avoid using gasoline, paint thinner, etc. when cleaning plastic parts, console, instrument cluster, etc.
- Use only water, mild soap, and a soft cloth when you clean these parts.
- Using gasoline, thinners, etc. can cause discoloration, cracking, or deformation of the part being cleaned.

Safety rules - Ecology and the environment

Soil, air, and water are vital factors of agriculture and life in general. When legislation does not yet rule the treatment of some of the substances required by advanced technology, sound judgment should govern the use and disposal of products of a chemical and petrochemical nature.

NOTE: *The following are recommendations that may be of assistance:*

- Become acquainted with and ensure that you understand the relative legislation applicable to your country.
- Where no legislation exists, obtain information from suppliers of oils, filters, batteries, fuels, antifreeze, cleaning agents, etc., with regard to their effect on man and nature and how to safely store, use, and dispose of these substances.

Helpful hints

- Avoid filling tanks using cans or inappropriate pressurized fuel delivery systems that may cause considerable spillage.
- In general, avoid skin contact with all fuels, oils, acids, solvents, etc. Most of them contain substances that may be harmful to your health.
- Modern oils contain additives. Do not burn contaminated fuels and or waste oils in ordinary heating systems.
- Avoid spillage when draining off used engine coolant mixtures, engine, gearbox and hydraulic oils, brake fluids, etc. Do not mix drained brake fluids or fuels with lubricants. Store them safely until they can be disposed of in a proper way to comply with local legislation and available resources.
- Modern coolant mixtures, i.e. antifreeze and other additives, should be replaced every two years. They should not be allowed to get into the soil, but should be collected and disposed of properly.
- Repair any leaks or defects in the engine cooling or hydraulic system immediately.
- Do not increase the pressure in a pressurized circuit as this may lead to a component failure.
- Protect hoses during welding as penetrating weld splatter may burn a hole or weaken them, allowing the loss of oils, coolant, etc.



SERVICE MANUAL

Engine

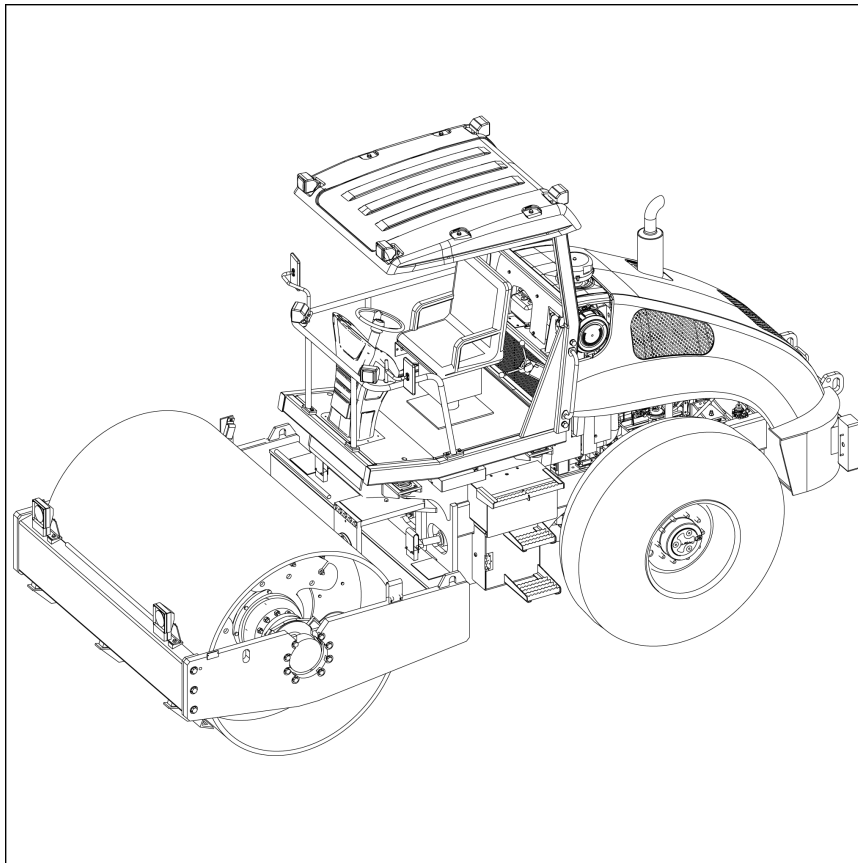

1107DX

Engine and crankcase - Disassemble - Top Engine

1. Disconnect the battery and store it in a dry place
2. Remove the radiator fan
3. Disconnect wiring from the alternator
4. Remove fan belt. Discard if it is damaged
5. Remove the alternator **(1)** from the engine

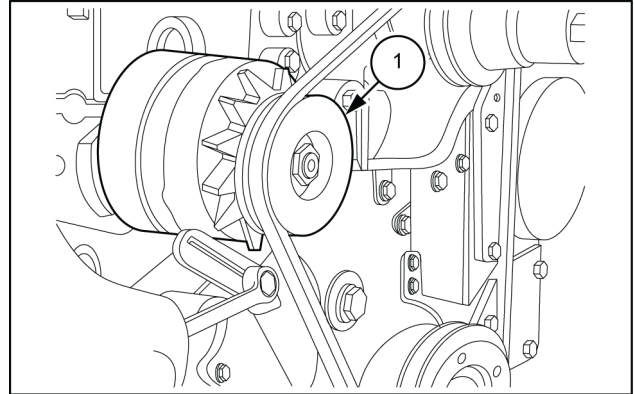

PTIL14COM0939AB 1

6. Drain out water from the radiator

NOTE: If coolant is used, collect it in a container and use again

7. Drain the lubricating oil from the sump and discard the O-ring from the drain plug
8. Disconnect the radiator from the engine and discard the old hoses
9. Disconnect the air cleaner and hose assembly from the bracket and inlet manifold. Discard the hose if it is cracked or damaged
10. Disconnect the exhaust pipe from the exhaust flange
11. Follow the procedure on turbocharger,
 1. Disconnect the rubber hose **(1)** connecting the air cleaner to the turbocharger

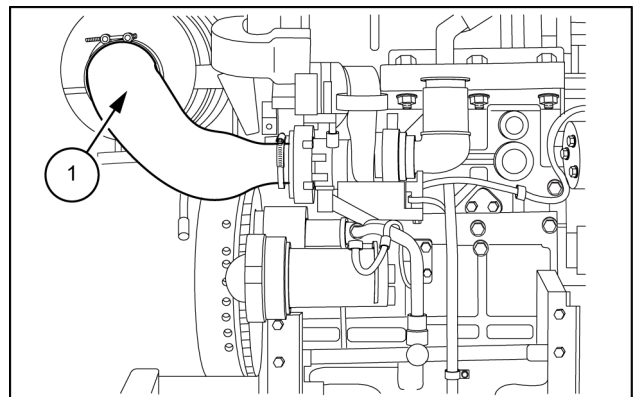

PTIL14COM0941AB 2

2. Disconnect the air delivery pipe with the heat shield from the turbocharger air outlet and air inlet manifold
3. Disconnect the exhaust pipe (1) from the turbocharger expansion bellow flange and discard the joint
4. Disconnect and remove the exhaust diffuser from the bracket

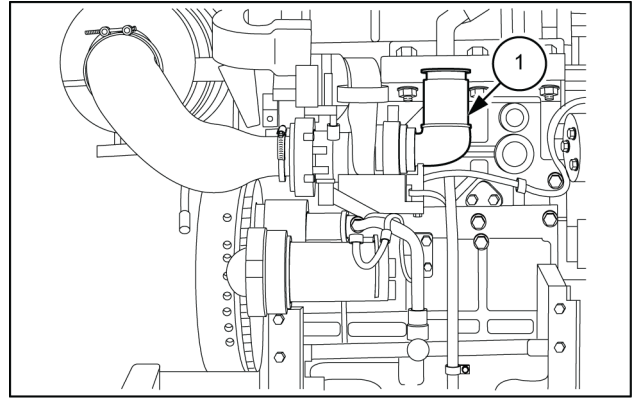

PTIL14COM0942AB 3

5. Disconnect the lubrication oil inlet (1) and drain pipe from the turbocharger

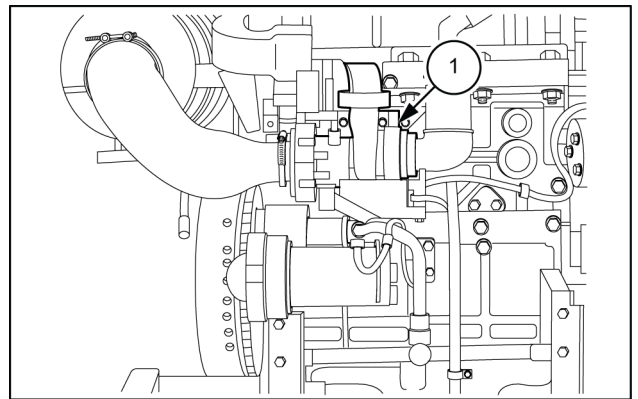

PTIL14COM0943AB 4

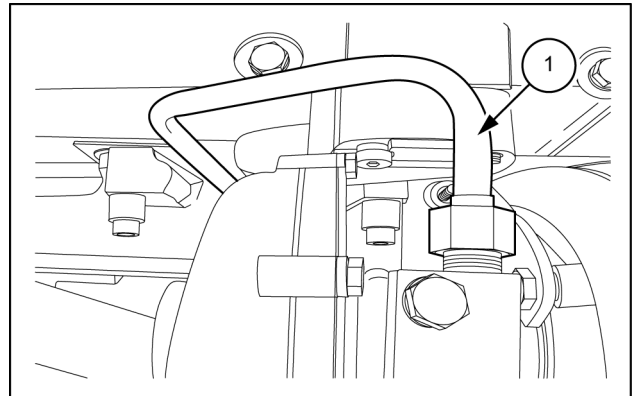

PTIL14COM1301AB 5

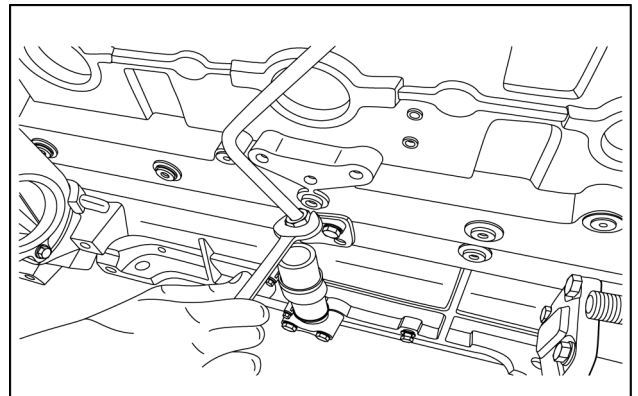

PTIL14COM1357AA 6

6. Disconnect the turbocharger from the exhaust manifold and discard the joint

7. Check turbocharger axial and radial play If play exceeds the recommended limits, recondition the turbocharger

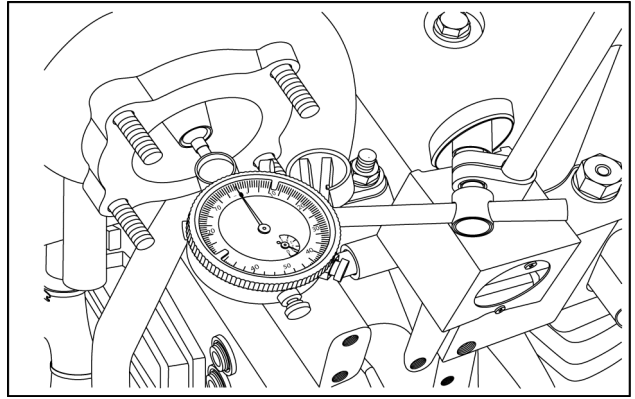

PTIL14COM1278AA 7

12. Disconnect and remove the high pressure pipe (1) between fuel pump and injectors.

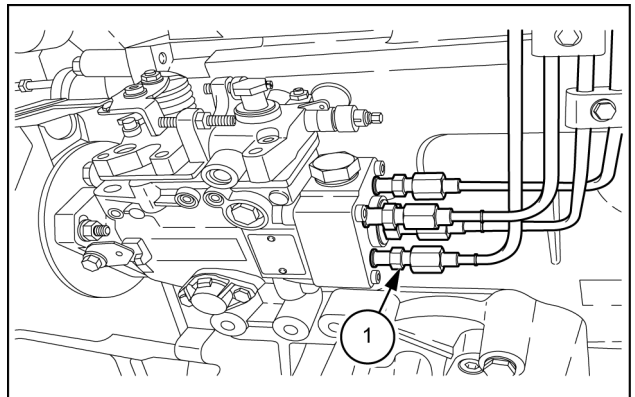

PTIL14COM1280AB 8

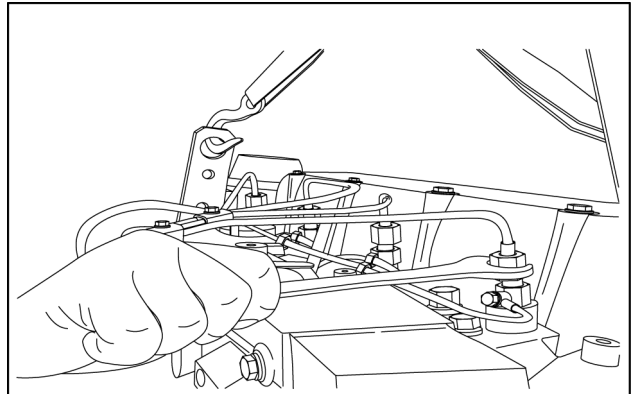

PTIL14COM1296AA 9

13. Close the fuel pump openings and the high pressure pipe openings with caps or tie the ends with a piece of clean plastic sheet

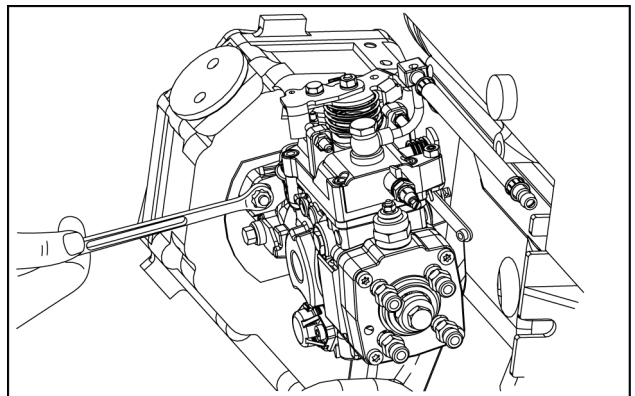

PTIL14COM0650AA 10

14. Disconnect and remove the leak off pipe and the fuel return extension (1)

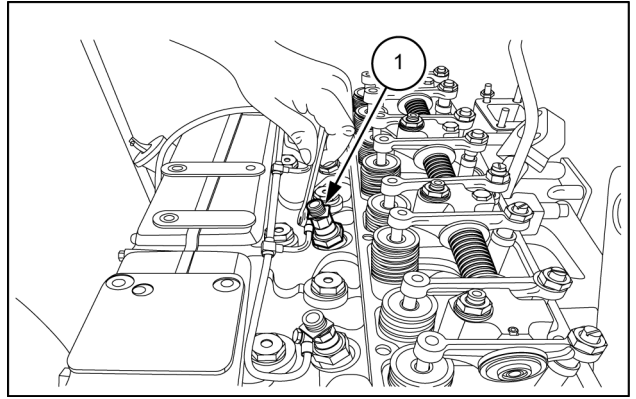

PTIL14COM1353AB 11

15. Remove the injector yoke (1)

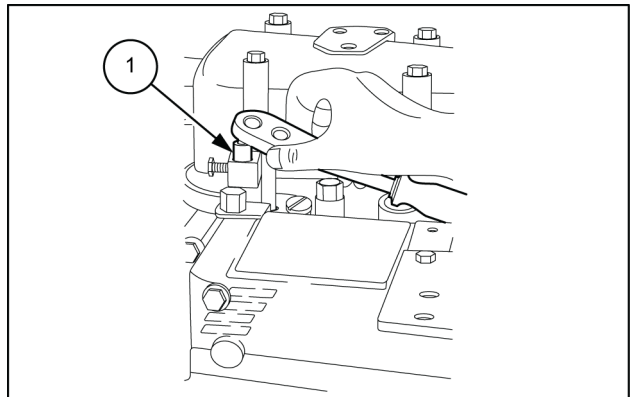

PTIL14COM0949AB 12

16. Remove the injector (1) from the head with the help of injector puller tool and discard the sealing ring
17. Remove and discard the nozzle sealing washers

NOTE: Use suitable tool to remove the washer

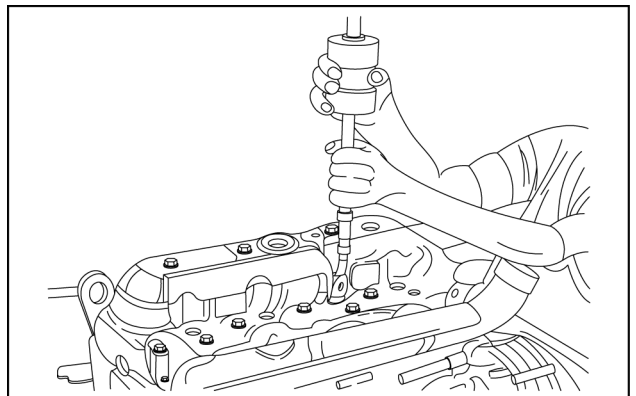

PTIL13TLB0746AA 13

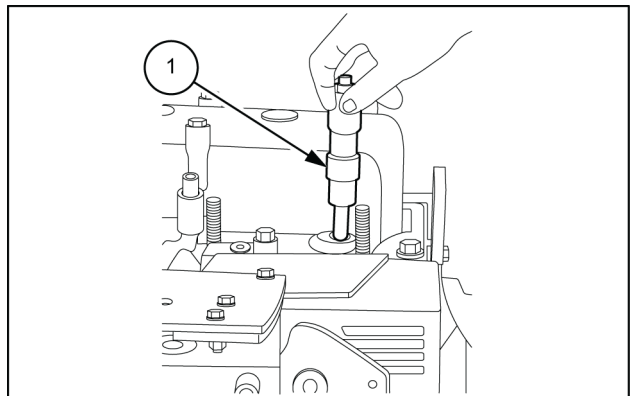

PTIL14COM0950AB 14

18. Loosen the mounting bolts and remove the inlet manifold.

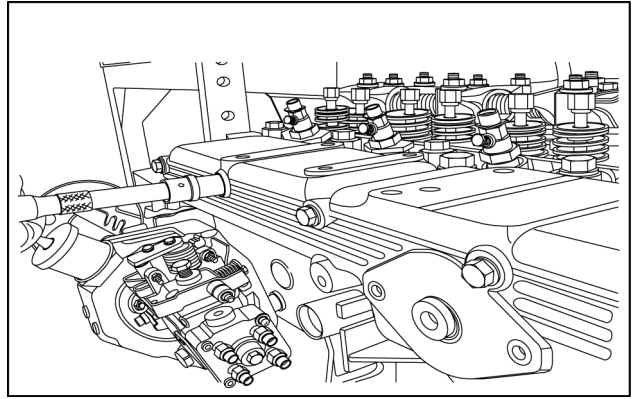

PTIL14COM1304AA 15

19. Loosen the mounting bolts and remove the exhaust manifold.

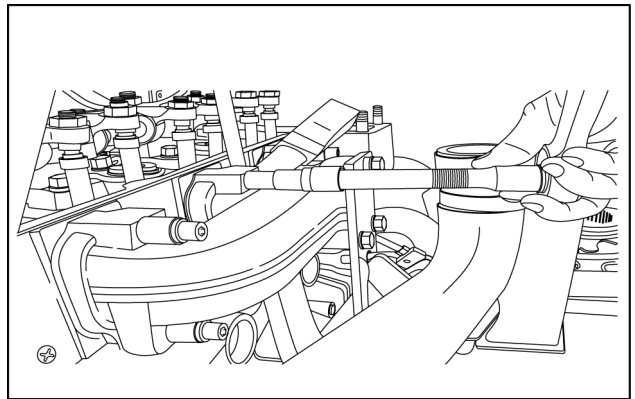

PTIL14COM1305AA 16

20. Using a suitable tool, loosen the oil filter (1) and discard the filter cartridge.

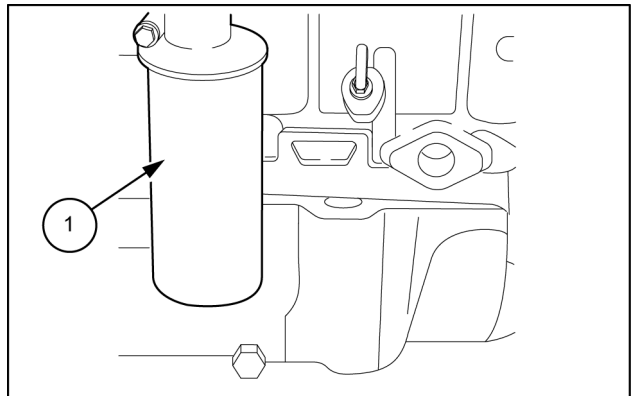

PTIL14COM0952AB 17

21. Disconnect and remove the breather assembly (1)

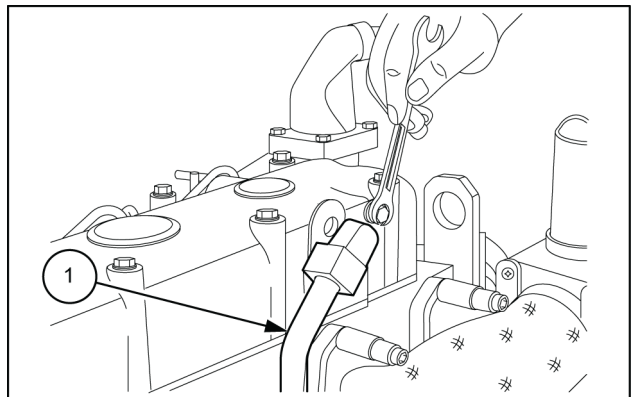

PTIL14COM0953AB 18

22. Disconnect the thermostat housing assembly **(1)** from the water pump and the cylinder head. Discard the thermostat and joints

NOTE: Ensure same connecting rod cap is installed to same connecting rod

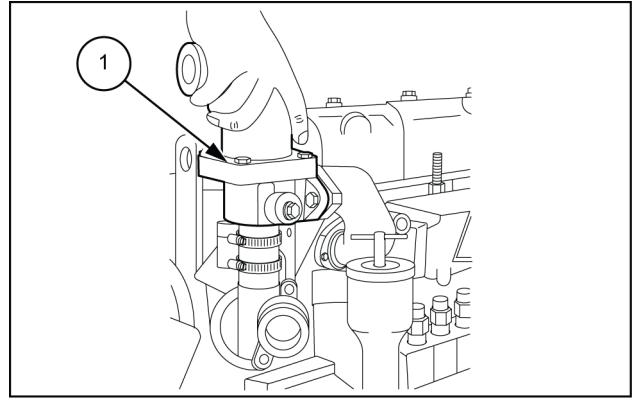

PTIL14COM0954AB 19

23. Remove the rocker cover **(1)** and discard the joint

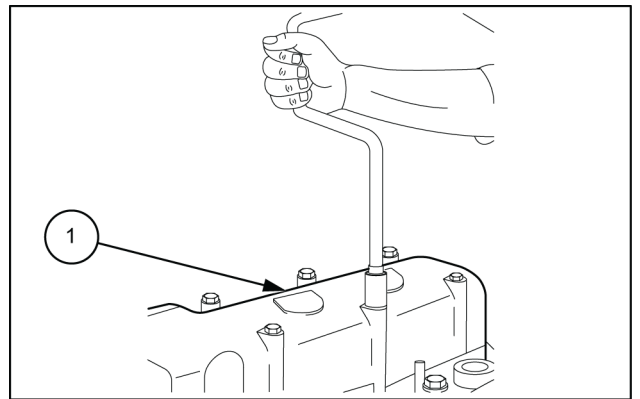

PTIL14COM0955AB 20

24. Loosen all valves adjusting lock nuts **(1)** and screws to reduce pressure on the rocker assembly

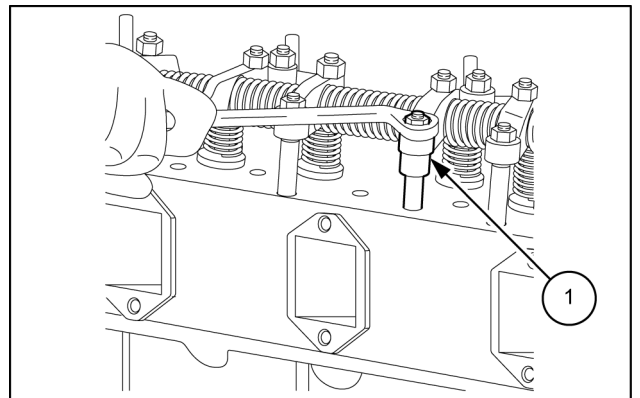

PTIL14COM0956AB 21

25. Remove the rocker assembly **(1)** from the head

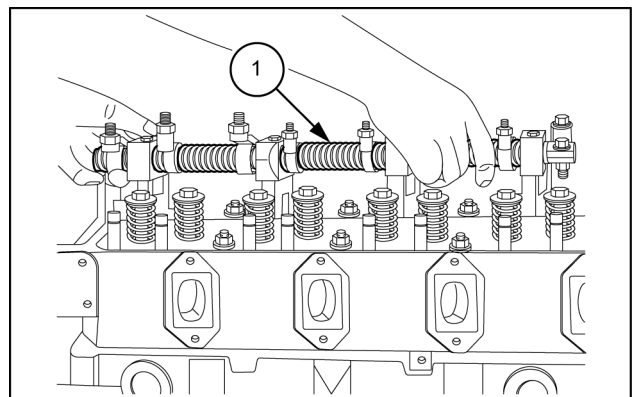

PTIL14COM0957AB 22

26. Remove the push rods (1) and keep them safely to avoid damage

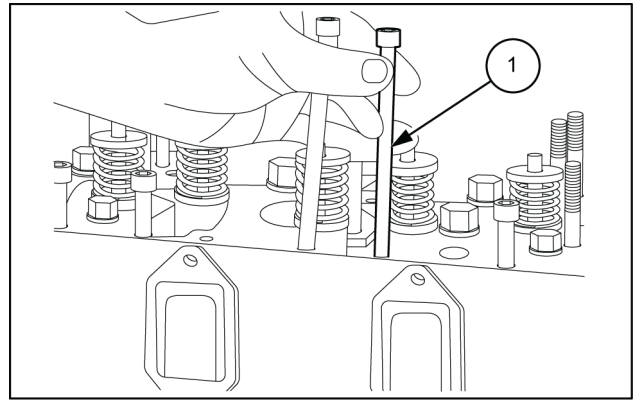

PTIL14COM0958AB 23

27. Loosen cylinder head bolts. Remove the cylinder head (1) from the engine block. Discard the cylinder head gasket

NOTE: Use proper hook with rope and connect to the cylinder head mounting brackets as shown in the image to lift it from the engine block

NOTE: Before removing the cylinder head ensure to loosen the mounting bolts of the cylinder head

NOTE: Ensure the inlet, exhaust manifold and rocker arm cover assembly on the cylinder head are removed

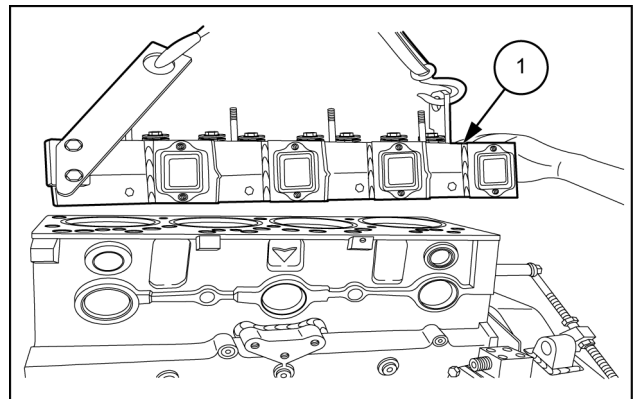

PTIL14COM1291AB 24

28. Loosen and remove the lubrication oil sump (1). Discard the joint

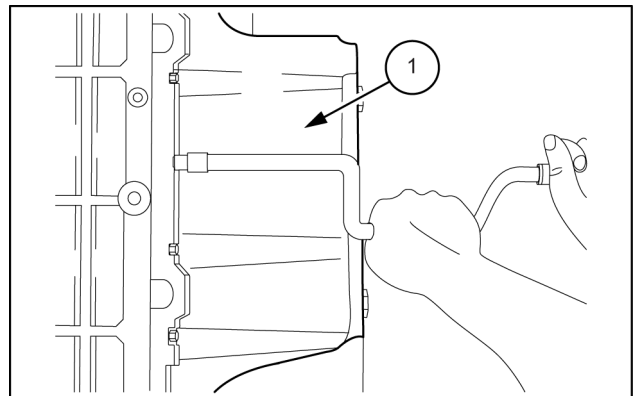

PTIL14COM0960AB 25

29. Remove the bolts (1) of the lubrication oil suction tube clamp. Loosen the union nut at the lubricating oil pump end and remove the suction tube assembly

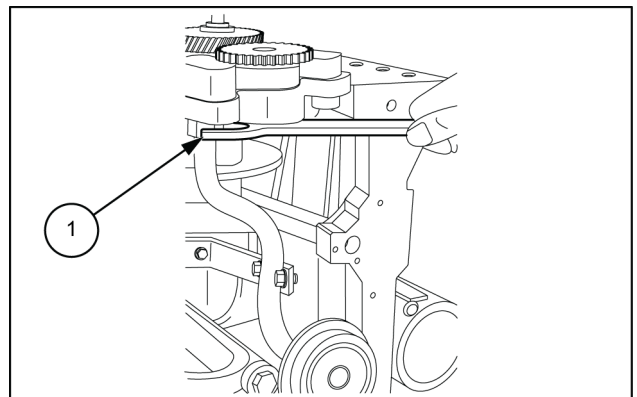

PTIL14COM0961AB 26

30. Loosen connecting rod cap bolts a few threads. Tap with a hammer on the bolts head to loosen the cap from the connecting rod. Remove the connecting rod cap along with the bearing shell. Do not disturb the combination of the connecting rod cap and bearing shell.
31. Tap the piston assembly **(1)** out from the oil sump side using a wooden handle and pull it out by hand from the top

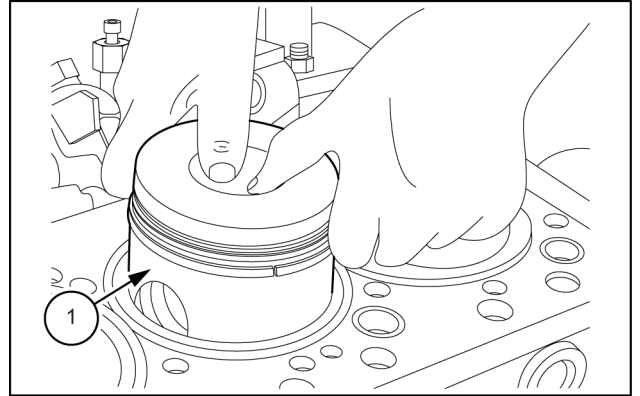

PTIL14COM0962AB 27

32. Using a circlip plier unlock the circlips **(1)** on either side of the piston.

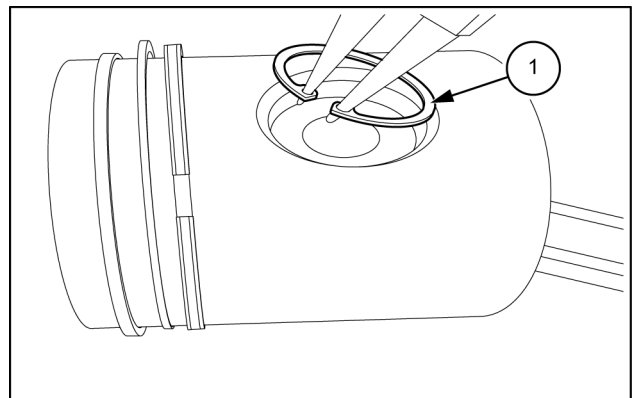

PTIL14COM1333AB 28

33. Remove the gudgeon pin **(3)** and take out the connecting rod **(1)** from the piston. **(2)**

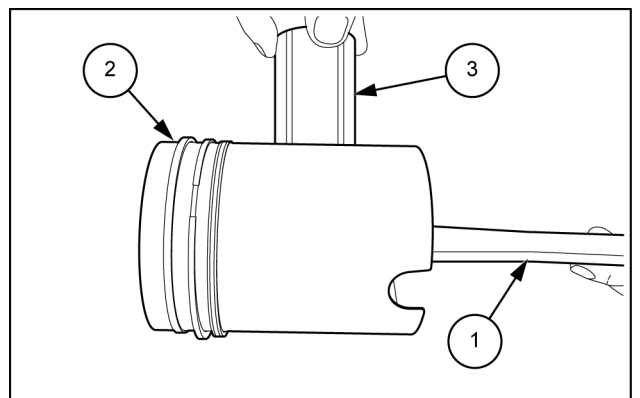

PTIL14COM1334AB 29

34. Check numbers on the connecting rod and cap and assemble as a set again

NOTE: Ensure same con rod cap is installed to same con rod

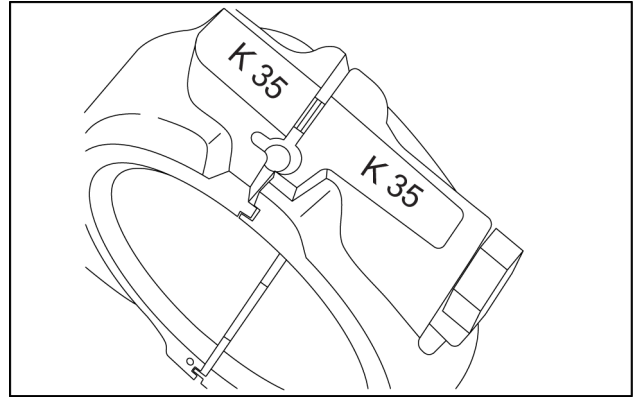

PTIL14COM0963AA 30

35. Punch the numbers on each connecting rod assembly

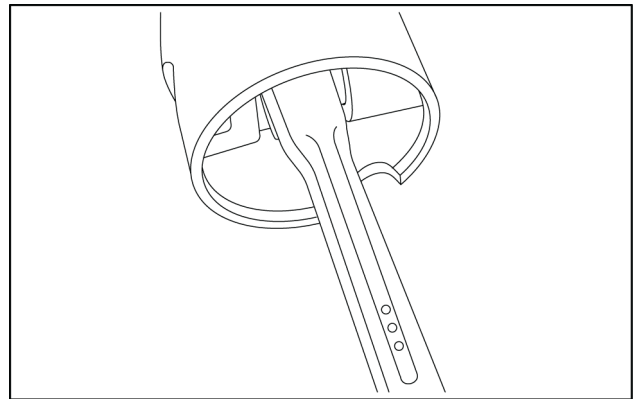

PTIL14COM0964AA 31

36. Follow the same procedure with the other pistons and connecting rod assemblies also
37. Remove piston rings (1) from the piston (2) with a ring expander. Discard the rings

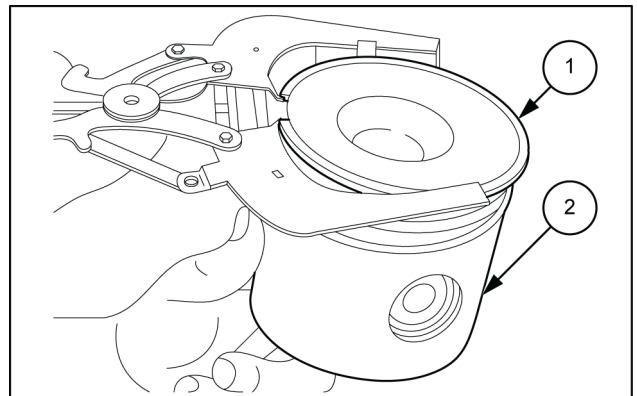

PTIL14COM0965AB 32



Suggest:

If the above button click is invalid.

Please download this document

first, and then click the above link

to download the complete manual.

Thank you so much for reading

Engine and crankcase - Assemble - Top engine

NOTE: Replace all the joints, gaskets, O-rings and copper washers

1. Replace the liners with new set of liner joint rings

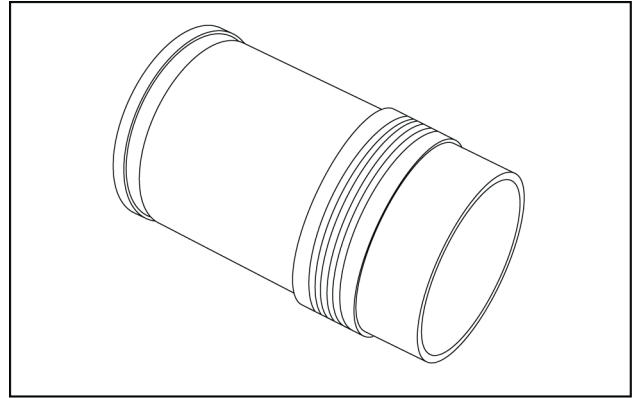

PTIL14COM0976AA 1

2. Apply recommended gasket cement to the liner collar or the crank case flange to prevent water leakage
3. Install liner in the crank case with liner pressing tool
Press the liner till it rests firmly in the crank case cavity
4. Measure the liner projection above the crankcase face with a dial gauge
5. Assemble the piston and connecting rod. Refer to **Connecting rods and pistons - Assemble (10.105)**
6. Install new piston rings into the piston grooves with a ring expander

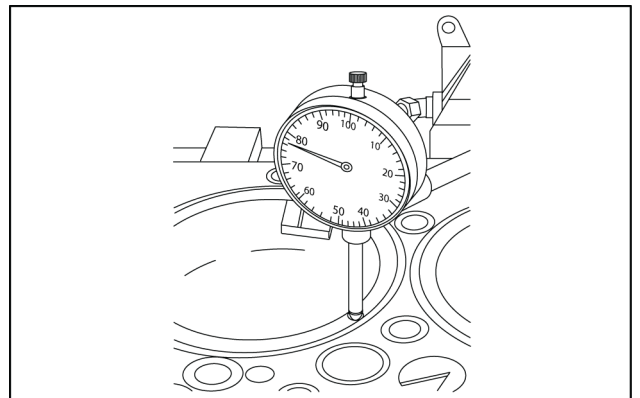

PTIL14COM0978AA 2

7. Set the ring gaps at **120 °** interval to each other

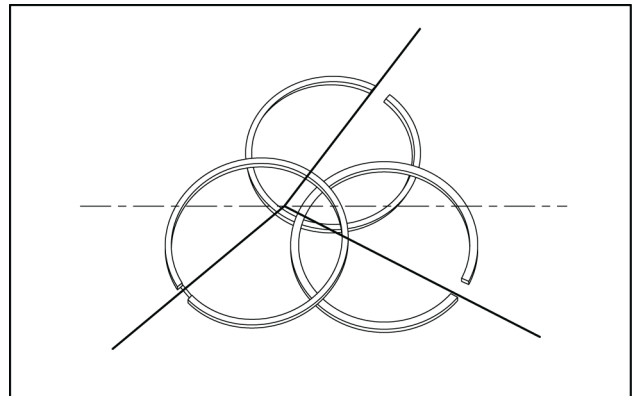

PTIL14COM0979AA 3

<https://www.ebooklibonline.com>

Hello dear friend!

Thank you very much for reading.

Enter the link into your browser.

The full manual is available for immediate download.

<https://www.ebooklibonline.com>