

**SERVICE
MANUAL**

**WE150 Compact
WE170 Compact
WE170C Railroad**
Wheeled Excavators

Print No. 84191448A

SERVICE MANUAL

**WE150 Compact
WE170 Compact
WE170C Railroad**
Wheeled Excavators

Print No. 84191448A



TO PREVENT ACCIDENTS

The majority of accidents and injuries which occur in industry, at home or on the road, are caused by the failure of some individual to follow simple and fundamental safety rules or precautions. For this reason **MOST ACCIDENTS CAN BE PREVENTED** by recognizing the real cause and taking the necessary precautions, before the accident occurs.

Regardless of the care used in design and construction of any type of equipment, there may be conditions that cannot be completely safeguarded against, without interfering with reasonable accessibility and efficient operation.

A careful operator and / or technician is the best insurance against accidents. The complete observance of one simple rule would prevent many thousands of serious injuries each year.

This rule is: never attempt to clean, lubricate or adjust a machine while it is in motion.

⚠ WARNING

Before carrying out any maintenance operation, adjustment and or repair on machines equipped with attachments, controlled hydraulically or mechanically, make sure that the attachment is lowered and safely set on the ground. If it is necessary to have the equipment partially or fully raised to gain access to certain items, be sure the equipment is suitably supported by means other than the hydraulic lift cylinders, cable and /or mechanical

SAFETY INSTRUCTION



This warning symbol points out important messages involving your safety.

Carefully read the safety rules contained herein and follow advised precautions to avoid potential hazards and to safeguard your safety and personal integrity.

In this manual you will find this symbol together with the following key-words:

DANGER

With specific warnings about potential dangers for the operator's or other persons integrity directly or indirectly involved.

WARNING

This symbol warns about the possibility of potential damages to the machine that can involve the operator's safety.

The non compliance with the warning preceded by the above mentioned key-words (**DANGER** and **WARNING**) can cause serious accidents or even the death of the persons involved.

Moreover, this Manual contains some instructions with texts in italics, preceded by the words **NOTE** and **CAUTION**:

NOTE: it emphasizes and underlines to the operator the correct technique or correct procedure to follow.

CAUTION

It warns the operator of a possible hazard of machine damage in case he does not follow a determined procedure.

INDEX

SECTION 01 - SAFETY PRECAUTIONS

- 1. INTRODUCTION 2
 - 1.1 DESIGNATED USE 2
- 2. GENERAL SAFETY INSTRUCTIONS 3
- 3. USE INSTRUCTION 12
 - 3.1 LEVEL OF VIBRATIONS TRANSMITTED TO THE OPERATOR 13
 - 3.2 NOISE LEVELS 14
 - 3.3 TRAVELLING ON PUBLIC ROADS 15

SECTION 02 - CONTROLS AND INSTRUMENTS

- 1. SWITCHES AND PUSH-BUTTONS 1
- 2. CONTROLS AND PEDALS 6
- 3. MULTI-FUNCTION DISPLAY 10

SECTION 03 - TECHNICAL SPECIFICATIONS

- 1. MAIN COMPONENTS 1
- 2. DIMENSIONS - OPERATING WEIGHTS 4
- 3. DIGGING PERFORMANCE 17
- 4. LIFTING CAPACITIES 29
- 5. HYDRAULIC SYSTEM 34
 - 5.1 PUMPS 34
- 6. SLEWING 35
 - 6.1 SLEWING GEARBOX 35
- 7. TRAVEL 36
- 8. TYRES 37
- 9. BRAKES 37
- 10. STEERING 37
- 11. ELECTRICAL SYSTEM 37
- 12. BUCKETS 38
- 13. TIGHTENING TORQUES 39
- 14. FUEL SYSTEM 39
- 15. ENGINE 39
- 16. SUPPLY SUMMARIZING CHART 40

SECTION 04 - UPPER STRUCTURE

- 1. MAIN COMPONENTS 1
- 2. SLEWING BEARING 2
- 3. SLEWING GEARBOX 6
 - 3.1 TECHNICAL SPECIFICATIONS 6
 - 3.2 REMOVAL AND INSTALLATION 9
 - 3.3 DISASSEMBLY AND ASSEMBLY 12
 - 3.4 SPECIAL TOOLS 36
 - 3.5 TROUBLESHOOTING 38

<https://www.ebooklibonline.com>

Hello dear friend!

Thank you very much for reading.

Enter the link into your browser.

The full manual is available for immediate download.

<https://www.ebooklibonline.com>

4. MULTI-COOLER.....	40
4.1 TECHNICAL SPECIFICATIONS.....	41
4.2 REMOVAL AND INSTALLATION EXPANSION TANK.....	42
4.3 COOLANT LEVEL, TOP-UP AND CHANGE.....	43
4.4 REMOVAL AND INSTALLATION OF FAN AND HYDRAULIC MOTOR.....	45
5. HYDRAULIC PUMPS.....	47
6. MUFFLER.....	48
7. HYDRAULIC OIL TANK.....	49
7.1 OIL RETURN FILTER.....	50
7.2 LEVEL CHECK AND TOP-UP.....	51
7.3 OIL CHANGE AND CLEANING.....	52
7.4 BLEEDING VALVE.....	54
8. AIR FILTER.....	55
9. COUNTERWEIGHT.....	55
10. FUEL SYSTEM.....	56
10.1 FUEL TANK.....	59
10.2 FUEL FILTERS.....	61
11. CAB AND OPERATOR'S SEAT.....	63
12. CENTRALIZED LUBRICATION.....	75
12.1 SAFETY INSTRUCTIONS.....	75
12.2 OPERATION.....	75
12.3 MAINTENANCE.....	76

SECTION 05 - UNDERCARRIAGE

1. UNDERCARRIAGE COMPONENTS.....	1
2. REAR RIGID AXLE.....	2
2.1 TECHNICAL SPECIFICATIONS.....	3
2.2 DISASSEMBLY.....	6
2.3 DISASSEMBLY AND ASSEMBLY.....	8
2.4 TROUBLESHOOTING.....	87
2.5 SPECIAL TOOLS.....	89
3. TRAVEL MOTOR.....	90
3.1 TECHNICAL SPECIFICATIONS.....	90
3.2 DISASSEMBLY AND ASSEMBLY.....	91
3.3 DISASSEMBLY AND ASSEMBLY.....	92
4. CARDAN SHAFT.....	103
4.1 DISASSEMBLY AND ASSEMBLY.....	104
5. FRONT STEERING AXLE.....	107
5.1 TECHNICAL SPECIFICATIONS.....	108
5.2 DISASSEMBLY AND ASSEMBLY.....	111
5.3 DISASSEMBLY AND ASSEMBLY.....	114
5.4 TROUBLESHOOTING.....	187
5.5 SPECIAL TOOLS.....	189
6. WHEELS AND TYRES.....	190
7. BLADE.....	194
7.1 BLADE CYLINDER.....	196
8. AXLE FLOATING LOCKING CYLINDERS.....	204
8.1 TECHNICAL SPECIFICATIONS.....	205

8.2	DISASSEMBLY AND ASSEMBLY	206
8.3	AIR BLEEDING.....	207
8.4	DISASSEMBLY AND ASSEMBLY	208
8.5	TROUBLESHOOTING.....	210
9.	STABILIZERS.....	211
9.1	STABILIZER CYLINDERS.....	214
9.2	TROUBLESHOOTING.....	223
10.	LEFT LADDER	225
11.	RIGHT LADDER AND TOOL STORAGE BOX.....	226
12.	ROTARY CONTROL VALVE AND ELECTRIC ROTOR	227
12.1	TECHNICAL SPECIFICATIONS	227
12.2	DISASSEMBLY AND ASSEMBLY	228
12.3	DISASSEMBLY AND ASSEMBLY	229
12.4	ELECTRIC ROTOR.....	231

SECTION 06 - FRONT ATTACHMENT

1.	TYPES OF FRONT ATTACHMENT	2
1.1	FRONT ATTACHMENT - WE150 Compact - WE170 Compact.....	2
1.2	FRONT ATTACHMENT - WE170C Railroad.....	3
2.	HYDRAULIC CYLINDERS.....	4
2.1	HYDRAULIC CYLINDERS - WE150 Compact - WE170 Compact.....	4
2.2	HYDRAULIC CYLINDERS - WE170C Railroad	5
2.3	BOOM CYLINDER.....	6
2.4	DIPPER CYLINDER	16
2.5	BUCKET CYLINDER.....	26
2.6	BOOM ADJUSTING CYLINDER	42
2.7	SPECIAL TOOLS	51
3.	BUCKETS.....	52
3.1	BUCKET TEETH - REPLACEMENT	54

SECTION 07 - STEERING SYSTEM

1.	OPERATION.....	1
2.	POWER STEERING.....	3
2.1	TECHNICAL SPECIFICATIONS	3
2.2	OPERATION.....	4
2.3	DISASSEMBLY AND ASSEMBLY	5
3.	PRIORITY VALVE	23
4.	TROUBLESHOOTING.....	24

SECTION 08 - BRAKE SYSTEM

1.	OPERATION.....	1
2.	SERVICE BRAKE.....	4
3.	PARKING BRAKE	7
4.	PEDAL BRAKE VALVE	8
5.	ACCUMULATORS.....	9
5.1	MAINTENANCE.....	10
6.	TROUBLESHOOTING.....	11

SECTION 09 - HYDRAULIC SYSTEM

1. HYDRAULIC SYSTEM	1
2. HYDRAULIC SYSTEM DIAGRAMS	5
2.1 HYDRAULIC SYSTEM DIAGRAMS - UPPER STRUCTURE	5
2.2 HYDRAULIC SYSTEM DIAGRAMS - UNDERCARRIAGE	19
2.3 HYDRAULIC SYSTEM DIAGRAMS BLADE AND/OR STABILIZERS	20
3. HYDRAULIC PUMPS	23
3.1 VARIABLE-FLOW RATE TWIN PUMP	24
3.2 ROTATION PUMP	37
3.3 GEAR PUMP	52
4. UPPER STRUCTURE CONTROL VALVE	53
5. UNDERCARRIAGE CONTROL VALVE	63
6. PILOT CONTROL ASSY	65
6.1 PILOT CONTROL ASSY SOLENOID VALVES	69
7. ROTATION SYSTEM	73
7.1 ROTATION GEARBOX	75
8. TRAVEL	77
8.1 TRAVEL MOTOR	80
9. STABILIZATION HYDRAULIC SYSTEM	86
10. BOOM HYDRAULIC SYSTEM	91
11. HYDRAULIC SYSTEM OF BUCKET	97
12. HYDRAULIC SYSTEM OF DIPPER	102
13. HYDRAULIC SYSTEM OF 2-PIECE BOOM	106
14. HYDRAULIC SYSTEM WITH COMBINATION OF DIFFERENT FUNCTIONS (BOOM, 2-PIECE BOOM, DIPPER AND BUCKET)	112
15. HYDRAULIC SYSTEM OF HAMMER (WITH 2-PIECE BOOM)	114
16. HYDRAULIC SYSTEM OF HAMMER AND SHEARS (WITH 2-PIECE BOOM)	117
17. HYDRAULIC SYSTEM OF SHEARS (WITH 2-PIECE BOOM)	122
18. HYDRAULIC SYSTEM OF HAMMER (WITH MONOBOOM)	125
19. HYDRAULIC SYSTEM OF HAMMER AND SHEARS (WITH MONOBOOM)	128
20. HYDRAULIC SYSTEM OF SHEARS (WITH MONOBOOM)	133
21. TROUBLESHOOTING	136

SECTION 10 - ELECTRICAL SYSTEM

1. ELECTRICAL DIAGRAMS	1
2. FUSES	39
2.1 FUSES - REPLACEMENT	41
3. BATTERIES	42
3.1 CLAMPS CHECK	42
3.2 CHARGE	43
3.3 REPLACEMENT	44
4. BULBS	45
4.1 CAB LIGHT	45
4.2 FRONT WORK LIGHTS	45
4.3 BOOM WORK LIGHT	46
4.4 TRAVEL LIGHT	46

4.5	TURN SIGNAL LIGHTS.....	47
4.6	REAR FLOODLAMPS	47
5.	TROUBLESHOOTING.....	48

SECTION 11 - ELECTRONICS

1.	MAIN COMPONENTS	1
2.	COMPONENTS OF LINE 1	3
2.1	MULTI-FUNCTION DISPLAY	3
2.2	CENTRAL UNIT.....	3
2.3	KEY-PAD MODULES	6
2.4	POWER CONTROL SYSTEM.....	7
2.5	DIAGNOSTICS SOCKET	9
2.6	ELECTRO-HYDRAULIC CONTROLLER	9
3.	COMPONENTS OF LINE CAN2.....	13
3.1	OPERATION.....	13
3.2	CENTRAL UNIT.....	14
3.3	HYDRAULIC CONTROL LEVERS	14
3.4	TRAVEL PEDAL	19
3.5	ATTACHMENT PEDAL (FOR HAMMER AND ADJUSTING CYLINDER)	20
3.6	POWER CONTROL SYSTEM.....	21
4.	ENGINE SPEED ACTUATOR	28
4.1	ENGINE SPEED SENSING.....	28
5.	COOLANT TEMPERATURE DETECTION.....	29
6.	CHARGE AIR TEMPERATURE DETECTION.....	30
7.	HYDRAULIC OIL TEMPERATURE DETECTION	31
8.	PROPORTIONAL VALVE - FAN MOTOR.....	32
9.	PROPORTIONAL VALVES - CONTROL BLOCK	33
10.	PILOT CONTROL BLOCK.....	34

SECTION 12 - CALIBRATION

1.	NECESSARY OPERATIONS BEFORE CALIBRATION	1
1.1	CALIBRATION OF THE MAIN PUMP	1
1.2	CALIBRATION OF THE ROTATION PUMP.....	2
2.	DISPLAY: CALIBRATION MENU	3
3.	CALIBRATIONS WITH THE ENGINE RUNNING.....	4
3.1	VDO CALIBRATION	6
3.2	POWER CALIBRATION	7
3.3	MAIN VALVE CALIBRATION (CONTROL VALVE).....	8
3.4	TRAVEL CALIBRATION	11
3.5	PUMP DELIVERY CALIBRATION.....	13
3.6	SLEWING PUMP CALIBRATION.....	16
3.7	AUXILIARY PRESSURE CALIBRATION	18
4.	CALIBRATIONS WITH THE ENGINE STOPPED	20
4.1	CALIBRATIONS, ALL SOLENOID VALVES, MAIN PUMP, ROTATION PUMP, AUXILIARY PRESSURE	22
4.2	MAIN VALVE CALIBRATION (CONTROL VALVE).....	24

SECTION 13 - FAULT CODES

1. ERROR INDICATION ON THE DISPLAY.....	1
2. CENTRAL UNIT AND ENGINE.....	3
2.1 FAULT CODES.....	3
3. PCS UNIT (POWER CONTROL SYSTEM).....	5
3.1 FAULT CODES.....	5
4. HYDRAULICS.....	6
4.1 SAFETY-RELATED SYSTEM DIAGNOSTIC FAULTS	6
4.2 COMMON FAULTS	7
4.3 CAN INTERFACE.....	10
4.4 DISPLAY INDICATORS.....	11
4.5 KEY PADS	11
4.6 COMMON DIGITAL INPUTS.....	12
4.7 HYDRAULIC CONTROL LEVER / PEDALS.....	13
4.8 PILOT PRESSURE SUPPLY.....	18
4.9 MAIN PUMPS	20
4.10 ATTACHMENT SENSORS.....	21
4.11 SLEWING SYSTEM.....	22
4.12 PILOT VALVES ON MAIN VALVE.....	24
4.13 ADDITIONAL VALVES AND SENSORS	28
4.14 AUTOMATIC CALIBRATION FAULTS	29

SECTION 01 - SAFETY PRECAUTIONS

1. INTRODUCTION	2
1.1 DESIGNATED USE	2
2. GENERAL SAFETY INSTRUCTIONS	3
3. USE INSTRUCTION	12
3.1 LEVEL OF VIBRATIONS TRANSMITTED TO THE OPERATOR	13
3.2 NOISE LEVELS	14
3.3 TRAVELLING ON PUBLIC ROADS	15

Carefully read the safety rules contained herein and follow advised precautions to avoid potential hazards and to safeguard your safety and personal integrity.

In this manual you will find the following indications:

▲ DANGER

With specific warnings about potential dangers for the operator's or other persons integrity directly or indirectly involved.

▲ WARNING

This symbol warns about the possibility of potential damages to the machine that can involve the operator's safety.

The non compliance with the warning preceded by the above mentioned key-words (**DANGER** and **WARNING**) can cause serious accidents or even the death of the persons involved.

Moreover, this Manual contains some instructions with texts in italics, preceded by the words **NOTE** and **CAUTION**, with following meanings for machine protection:

NOTE: it emphasizes and underlines to the operator the correct technique or correct procedure to follow.

▲ WARNING

It warns the operator of a possible hazard of machine damage in case he does not follow a determined procedure.

Your safety and that of people around you depends on you. It is essential that you understand this manual for the correct operation, inspection, lubrication and maintenance of this machine.



1. INTRODUCTION

The wheeled excavators WE150 Compact - WE170 Compact - WE170C Railroad are operation hydraulic machines.

They essentially consist in a wheeled undercarriage on which a slewing bearing is mounted, which is coupled to the upper frame.

The upper frame supports the front attachment, the engine, the hydraulic components, the cab, the fuel tank and the counterweight.

When the operator activates the controls (hydraulic control levers and pedals), the hydraulic pumps rotated by the engine suck oil from the tank and convey it to the control valve; the control valve, in turn, sends it to the relevant users.

A cooling system keeps the hydraulic fluid at a normal operating temperature.

1.1 DESIGNATED USE

The machine has been built in accordance with state-of-the-art standards and the recognized safety rules.

The machine must be used in accordance with its designated use, by observing the safety and precautionary rules and by strictly following the operating instructions. Any functional disorders, especially those affecting the safety of the machine, should therefore be rectified immediately.

The Excavator is intended to be used in digging and loading operation (with bucket or grab or clamshell bucket), ground levelling (with blade when installed) and use of hydraulic hammer to break concrete or other solid material.

⚠ DANGER ⚠

A different use of the excavator or of its working equipment:

- for lifting or transporting persons;
- as a working platform;
- for lifting loads without the attachment being approved for this purpose;
- for pulling slung loads;
- for driving in posts, supports, sheet-piles, without the attachment being approved for this purpose;

is considered contrary to the designated use.

Improper use may cause injury or life-threatening risks for the operator and for other persons.

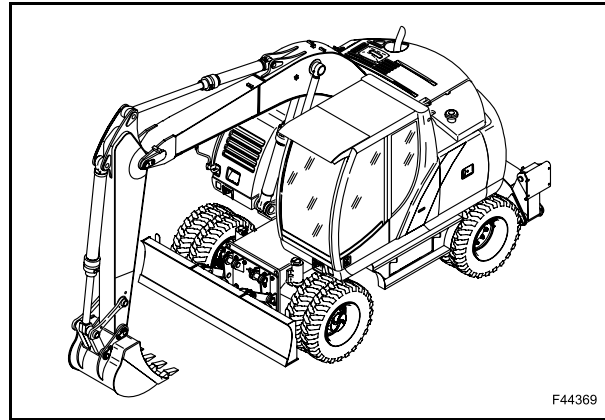

1

The manufacturer/supplier cannot be held responsible for any damage resulting from other than the designated use. The risk involved in such misuse lies entirely with the user.

⚠ DANGER ⚠

For clarity purposes, some figures in this Manual show the machine with protection panels or covers removed. Never operate the machine with any protection panels or covers removed.

⚠ DANGER ⚠

It is absolutely forbidden to tamper and/or change the setting of any of the hydraulic system valves to avoid damaging machine components with consequent risks to personal safety.

2. GENERAL SAFETY INSTRUCTIONS

Carefully read this Manual before proceeding with maintenance, repairs, refuelling or other machine operations.

Repairs have to be carried out only by authorized and instructed staff; specific precautions have to be taken when grinding, welding or when using mallets or heavy hammers.

Not authorized persons are not allowed to repair or carry out maintenance on this machine. Do not carry out any work on the equipment without prior authorization.

Ask your employer about the safety instructions in force and safety equipment.

Nobody is allowed to seat on the operator's place during machine maintenance unless he is a qualified operator helping with the maintenance work.

If it is necessary to move the equipment to carry out repairs or maintenance, do not lift or lower the equipment from any other position than the operator's seat.

Never carry out any operation on the machine when the engine is running, except when specifically indicated.

Stop the engine and ensure that all pressure is relieved from hydraulic circuits before removing caps, covers, valves, etc.

All repair and maintenance operations should be carried out with the greatest care and attention.

Service stairs and platforms used in a workshop or in the field should be built in compliance with the safety rules in force.

Any functional disorders, especially those affecting the safety of the machine, should therefore be rectified immediately.

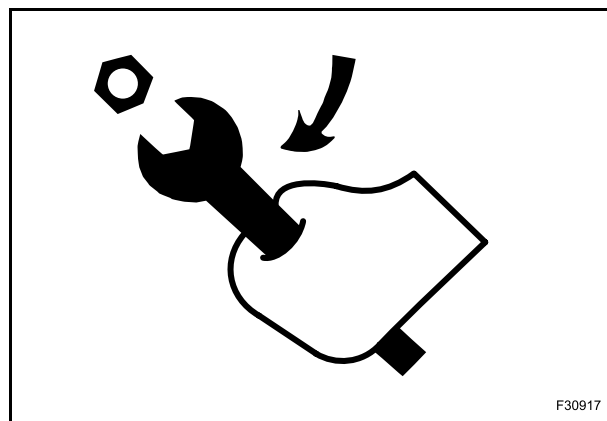

2.1 EMERGENCY

Be prepared for emergencies. Always keep at disposal on the machine a first aid kit and a fire extinguisher. Make sure that the fire extinguisher is serviced in accordance with the manufacturer's instructions.

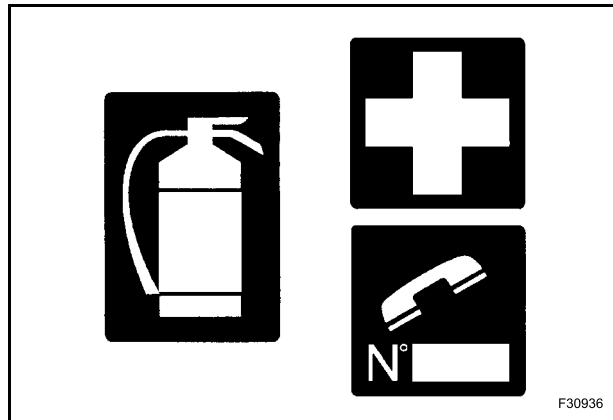

2.2 EQUIPMENT

Wear close fitting clothing and safety equipment appropriate for the job:

- safety helmet;
- safety shoes;
- heavy gloves;
- reflective clothing;
- wet weather clothing.

If environment condition require it following personal safety equipment should be at hand:

- respirators (or dustproof masks);
- ear plugs or acoustic ears protections;
- goggles with lateral shield or masks for eyes protection.

Do not wear rings, wristwatches, jewels, unbuttoned or flapping clothing such as ties, torn clothes, scarves, open jackets or shirts with open zips which could get caught into moving parts.

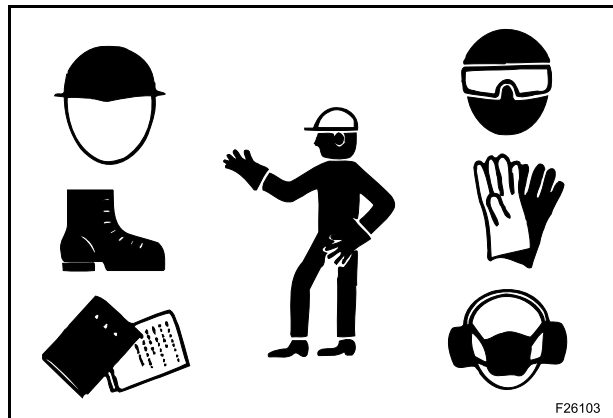

2.3 ENGINE - RADIATOR

Never leave the engine run in closed spaces without ventilation and not able to evacuate toxic exhaust gases. Keep the exhaust manifold and tube free from combustion materials.

Do not refuel with the engine running, especially if hot, as this increases fire hazard in case of fuel spillage.

Never attempt to check or adjust the fan belts when the engine is running.

Never lubricate the machine with the engine running.

Pay attention to rotary pieces and do not allow to anyone to approach to avoid becoming entangled.

If hands, clothes or tools get caught in the fan blades or in the transmission belt, this can cause amputations, violent tears and generate condition of serious danger; for this reason avoid touching or to come close to all rotary or moving parts.

A violent jet of the coolant from the radiator can cause damages and scalds.

If you are to check the coolant level, you have to shut off the engine previously and to let cool down the radiator and its pipes. Slowly unscrew the cap to release the inside pressure.

If necessary, remove the cap with hot engine, wear safety clothes and equipment, then loosen the cap slowly to relieve the pressure gradually.

When checking the fuel, oil and coolant levels, use exclusively explosion proof classified lamps. If this kind of lamps are not used fires or explosions may occur.

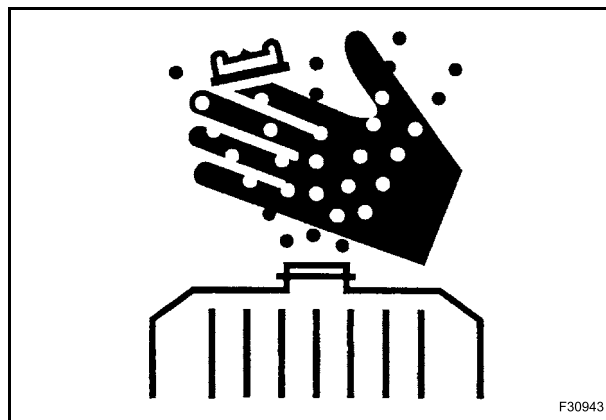
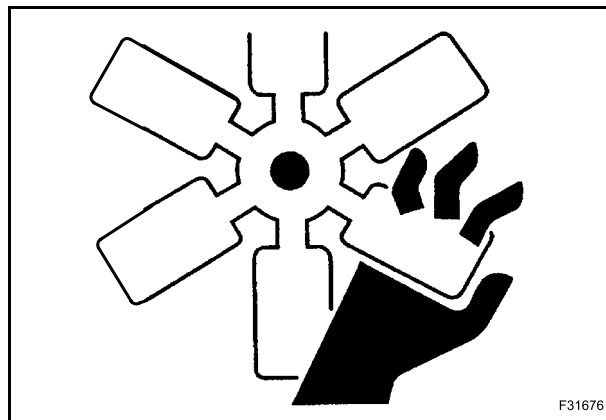

2.4 HYDRAULIC SYSTEMS

Splashes of fluids under pressure can penetrate the skin causing serious injuries.

Avoid this hazard by relieving pressure before disconnecting hydraulic or other lines.

Relieve the residual pressure by moving the hydraulic control levers several times.

Tighten all connections before applying pressure.

To protect the eyes wear a facial shield or safety goggles.

Protect your hands and body from possible splashes of fluids under pressure.

Swallowing hydraulic oil is a severe health hazard.

When hydraulic oil has been swallowed, avoid vomiting, but consult a doctor or go to a hospital.

If an accident occurs, see a doctor familiar with this type of injury immediately.

Any fluid penetrating the skin must be removed within few hours to avoid serious infections.

Flammable splashes may originate because of the heat near pipes with fluids under pressure, with the result of serious scalds for the persons hit. Do not weld or use torches near pipes containing fluids or other flammable materials.

Pipes under pressure can accidentally be pierced when the heat expands beyond the area immediately heated.

Arrange for fire resistant temporary shields to protect hoses or other components during welding.

Have any visible leakage repaired immediately.

Escaping oil pollutes the environment. Soak up any oil that has escaped with a proper binding agent. Sweep up binding agent and dispose of it separately from other waste.

Never search for leakages with the fingers, but use a piece of cardboard and always wear goggles.

Never repair damaged piping; always replace it. Replace hydraulic hoses immediately on detecting any damage or moist areas.

Always store hydraulic oil in the original containers.

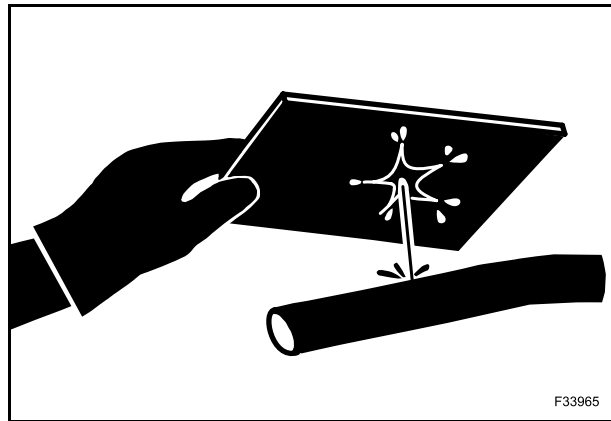
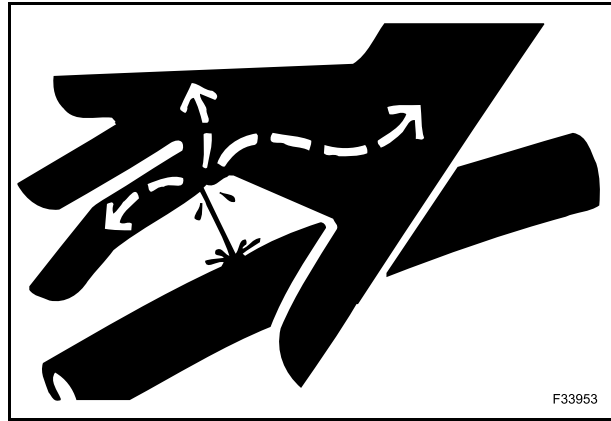



Suggest:

If the above button click is invalid.

Please download this document

first, and then click the above link

to download the complete manual.

Thank you so much for reading

HOSES AND TUBES

Always replace hoses and tubes if the cone end or the end connections on the hose are damaged.

When installing a new hose, loosely connect each end and make sure the hose takes up the correct position before tightening the connections. Clamps should be tightened sufficiently to hold the hose without crushing and to prevent chafing.

After hose replacement to a moving component, check that the hose does not foul by moving the component through the complete range of travel.

Be sure any hose which has been installed is not kinked or twisted.

Hose connections which are damaged, dented, crushed or leaking, restrict oil flow and the productivity of the components being served. Connectors which show signs of movement from the original position have failed and will ultimately separate completely.

A hose with a frayed outer sheath will allow the water penetration. Concealed corrosion of the wire reinforcement will subsequently occur along the hose length with resultant hose failure.

Ballooning of the hose indicates an internal leakage due to structural failure. This condition rapidly deteriorates and total hose failure soon occurs.

Kinked, crushed, stretched or deformed hoses generally suffer internal structural damage which can result in oil restriction, a reduction in the speed of operation and ultimate hose failure.

Free-moving, unsupported hoses must never be allowed to touch each other or related working surfaces. This causes chafing which reduces hose life.

O-RINGS

Replace O-rings, seal rings and gaskets whenever they are disassembled.

Never mix new and old seals or O-rings, regardless of condition. Always lubricate new seal rings and O-rings with hydraulic oil before installation to relevant seats.

This will prevent the O-rings from rolling over and twisting during mounting which will jeopardize sealing.

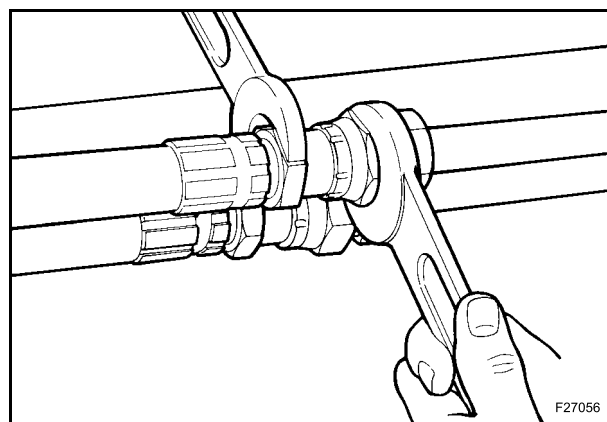

<https://www.ebooklibonline.com>

Hello dear friend!

Thank you very much for reading.

Enter the link into your browser.

The full manual is available for immediate download.

<https://www.ebooklibonline.com>