

SERVICE MANUAL

W110D Tier2 Wheel Loader

Part number 48083743

English
July 2018





SERVICE MANUAL

W110 D ZBAR, NEW CAB - EH, TIER2

Link Product / Engine

Product	Market Product	Engine
W110 D ZBAR, NEW CAB - EH, TIER2	Australia New Zealand	F4HFE413N*B001
W110 D ZBAR, NEW CAB - EH, TIER2	Asia Pacific	F4HFE413N*B001
W110 D ZBAR, NEW CAB - EH, TIER2	Middle East Africa	F4HFE413N*B001
W110 D ZBAR, NEW CAB - EH, TIER2	Latin America	F4HFE413N*B001

<https://www.ebooklibonline.com>

Hello dear friend!

Thank you very much for reading.

Enter the link into your browser.

The full manual is available for immediate download.

<https://www.ebooklibonline.com>

Contents

INTRODUCTION

Engine	10
[10.001] Engine and crankcase	10.1
[10.216] Fuel tanks	10.2
[10.202] Air cleaners and lines	10.3
[10.254] Intake and exhaust manifolds and muffler	10.4
[10.400] Engine cooling system	10.5
[10.414] Fan and drive	10.6
[10.310] Aftercooler.....	10.7
[10.304] Engine lubrication system.....	10.8
Transmission	21
[21.113] Powershift transmission	21.1
[21.135] Powershift transmission external controls.....	21.2
[21.155] Powershift transmission internal components.....	21.3
Four-Wheel Drive (4WD) system	23
[23.314] Drive shaft.....	23.1
Front axle system	25
[25.100] Powered front axle	25.1
[25.102] Front bevel gear set and differential	25.2
[25.108] Final drive hub, steering knuckles, and shafts	25.3
[25.310] Final drives	25.4
Rear axle system	27
[27.100] Powered rear axle.....	27.1
[27.106] Rear bevel gear set and differential	27.2
[27.120] Planetary and final drives	27.3
[27.124] Final drive hub, steering knuckles, and shafts	27.4

Brakes and controls	33
[33.202] Hydraulic service brakes	33.1
[33.110] Parking brake or parking lock	33.2
Hydraulic systems	35
[35.000] Hydraulic systems.....	35.1
[35.300] Reservoir, cooler, and filters.....	35.2
[35.106] Variable displacement pump	35.3
[35.359] Main control valve	35.4
[35.357] Pilot system	35.5
[35.204] Remote control valves	35.6
[35.752] Hydraulic fan drive cooling system.....	35.7
[35.701] Front loader arm hydraulic system	35.8
[35.723] Front loader bucket hydraulic system	35.9
[35.734] Tool quick coupler hydraulic system	35.10
Frames and ballasting	39
[39.100] Frame	39.1
Steering	41
[41.200] Hydraulic control components.....	41.1
[41.216] Cylinders	41.2
[41.910] Auxiliary steering	41.3
Wheels	44
[44.511] Front wheels.....	44.1
[44.520] Rear wheels.....	44.2
Cab climate control	50
[50.100] Heating	50.1
[50.200] Air conditioning	50.2
Electrical systems	55
[55.000] Electrical system	55.1

[55.100] Harnesses and connectors.....	55.2
[55.201] Engine starting system	55.3
[55.301] Alternator.....	55.4
[55.302] Battery.....	55.5
[55.512] Cab controls.....	55.6
[55.050] Heating, Ventilation, and Air-Conditioning (HVAC) control system.....	55.7
[55.415] Loader arm and bucket control system	55.8
[55.530] Camera.....	55.9
[55.DTC] FAULT CODES.....	55.10
Front loader and bucket.....	82
[82.100] Arm.....	82.1
[82.300] Bucket.....	82.2
Platform, cab, bodywork, and decals.....	90
[90.150] Cab.....	90.1
[90.120] Mechanically-adjusted operator seat.....	90.2
[90.124] Pneumatically-adjusted operator seat.....	90.3
[90.105] Machine shields and guards	90.4



INTRODUCTION

Safety rules

Personal safety





This is the safety alert symbol. It is used to alert you to potential personal injury hazards. Obey all safety messages that follow this symbol to avoid possible death or injury.

Throughout this manual you will find the signal words DANGER, WARNING, and CAUTION followed by special instructions. These precautions are intended for the personal safety of you and those working with you.

Read and understand all the safety messages in this manual before you operate or service the machine.

 DANGER indicates a hazardous situation that, if not avoided, will result in death or serious injury.

 WARNING indicates a hazardous situation that, if not avoided, could result in death or serious injury.

 CAUTION indicates a hazardous situation that, if not avoided, could result in minor or moderate injury.

FAILURE TO FOLLOW DANGER, WARNING, AND CAUTION MESSAGES COULD RESULT IN DEATH OR SERIOUS INJURY.

Machine safety

NOTICE: Notice indicates a situation that, if not avoided, could result in machine or property damage.

Throughout this manual you will find the signal word Notice followed by special instructions to prevent machine or property damage. The word Notice is used to address practices not related to personal safety.

Information

NOTE: Note indicates additional information that clarifies steps, procedures, or other information in this manual.

Throughout this manual you will find the word Note followed by additional information about a step, procedure, or other information in the manual. The word Note is not intended to address personal safety or property damage.

Personal safety

Carefully read this Manual before proceeding with maintenance, repairs, refuelling or other machine operations.

Repairs have to be carried out only by authorized and instructed staff; specific precautions have to be taken when grinding, welding or when using mallets or heavy hammers.

Non-authorized persons are not allowed to repair or carry out maintenance on this machine. Do not carry out any work on the equipment without prior authorization.

Ask your employer about the safety instructions in force and safety equipment.

Nobody should be allowed in the cab during machine maintenance unless he is a qualified operator helping with the maintenance work.

If it is necessary to move the equipment to carry out repairs or maintenance, do not lift or lower the equipment from any other position than the operator's seat.

Never carry out any operation on the machine when the engine is running, except when specifically indicated.

Stop the engine and ensure that all pressure is relieved from hydraulic circuits before removing caps, covers, valves, etc.

All repair and maintenance operations should be carried out with the greatest care and attention.

Service stairs and platforms used in a workshop or in the field should be built in compliance with the safety rules in force.

Any functional disorders, especially those affecting the safety of the machine, should therefore be rectified immediately.

⚠ DANGER

Unexpected movement!

Make sure parking brake is applied. Secure machine with wheel chocks.

Failure to comply will result in death or serious injury.

D0013A

Before performing any work on the machine, attach a maintenance in progress tag. This tag can be applied on the left-hand control lever, safety lever or cab door.

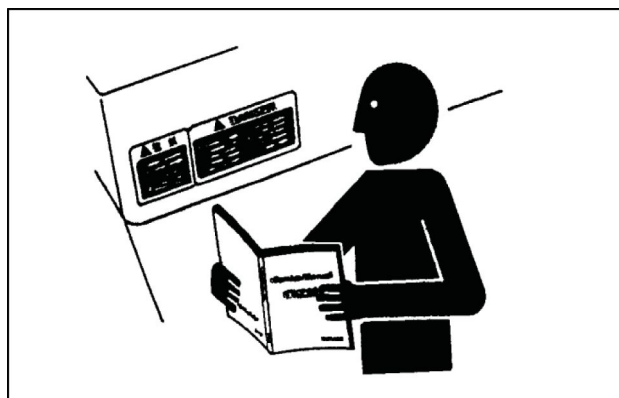

TULI12WEX2004AA 1

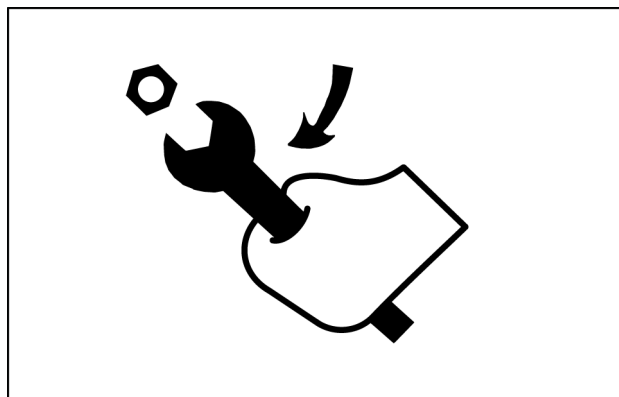

TULI12WEX2005AA 2

Emergency

Be prepared for emergencies. Always keep a fire extinguisher and first aid kit readily available. Ensure that the fire extinguisher is serviced in accordance with the manufacturer's instructions.

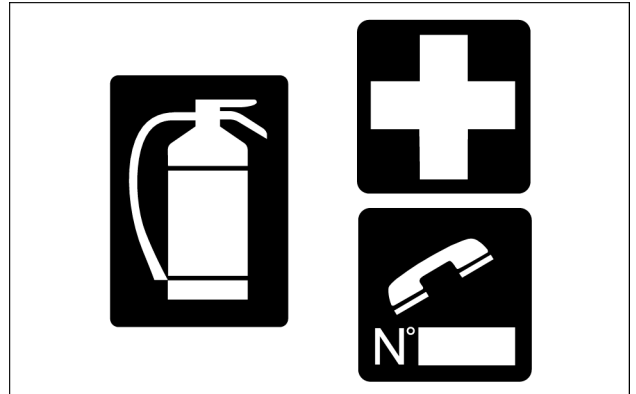

SMIL12WEX0174AA 3

Equipment

Wear close fitting clothing and safety equipment appropriate for the job:

- Safety helmet
- Safety shoes
- Heavy gloves
- Reflective clothing
- Wet weather clothing

If working conditions require, the following personal safety equipment should be on hand:

- Respirators (or dust proof masks)
- Ear plugs or acoustic ears protections
- Goggles with lateral shield or masks for eye protection

Do not wear rings, wristwatches, jewelry, unbuttoned or flapping clothing such as ties, torn clothes, scarves, open jackets or shirts with open zips which could get caught into moving parts.

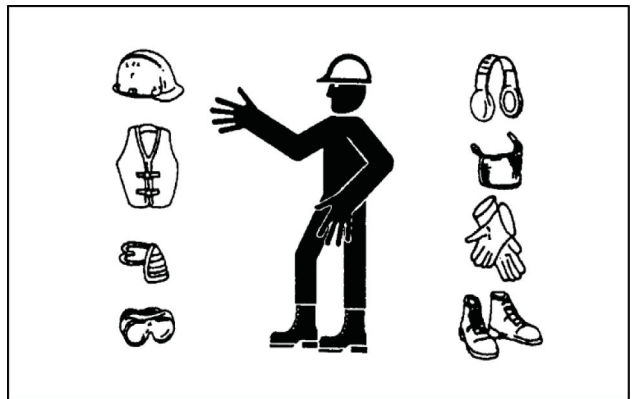

TULI12WEX2008AA 4

Engine - Radiator

Never leave the engine running in enclosed spaces without proper ventilation which is able to evacuate toxic exhaust gases- Keep the exhaust manifold and tube free from combustible materials.

Do not refuel with the engine running, especially if hot, as this increases fire hazard in case of fuel spillage.

Never attempt to check or adjust the belts when the engine is running.

Never lubricate the machine with the engine running.

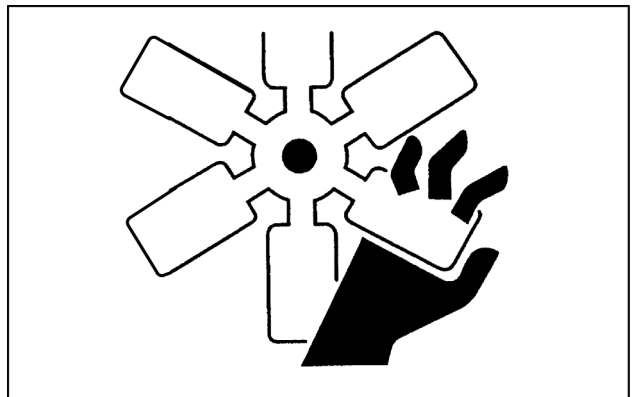

TULI12WEX2009AA 5



SERVICE MANUAL

Engine

W110 D ZBAR, NEW CAB - EH, TIER2

Engine - General specification

Engine with 4 Speed Transmission	
A. Low idle	1020 – 1080 RPM
Alternate low idle	870 – 930 RPM
Alternate accelerated idle	1270 – 1330 RPM
Working idle (setting from factory)	1120 – 1180 RPM
B. Maximum No Load RPM	2075 – 2245 RPM
C. Converter Stall	1950 – 2030 RPM
D. Hydraulic Stall	1900 – 2100 RPM
E. Converter & Hydraulic Stall	1400 – 1600 RPM
Temperature of the torque converter oil	82 – 104 °C (180 – 219 °F)
Temperature of the hydraulic oil	54 – 57 °C (129 – 135 °F)

NOTE: hydraulic stall and converter and hydraulic stall RPM values are read with the lift arms raised, the bucket held in rolled back position, and the engine at Wide Open Throttle (WOT) in maximum power mode with the transmission in manual mode and in third gear.

Engine - Remove

1. Park the machine on a level surface and lower the bucket to the ground. Put the articulation lock in the LOCKED position.

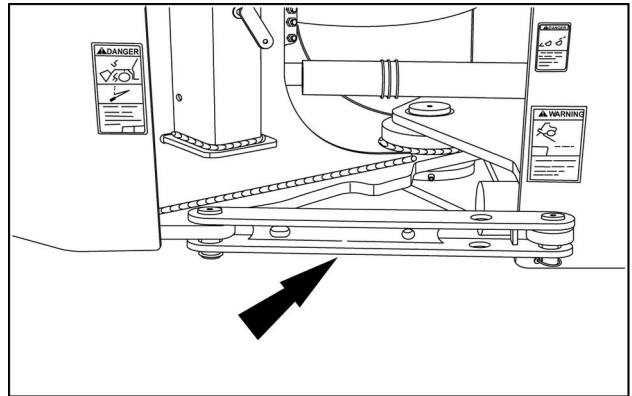

RAPH12WEL1412AA 1

2. Turn the engine OFF. Actuate the brake pedal several times to discharge the brake accumulators.

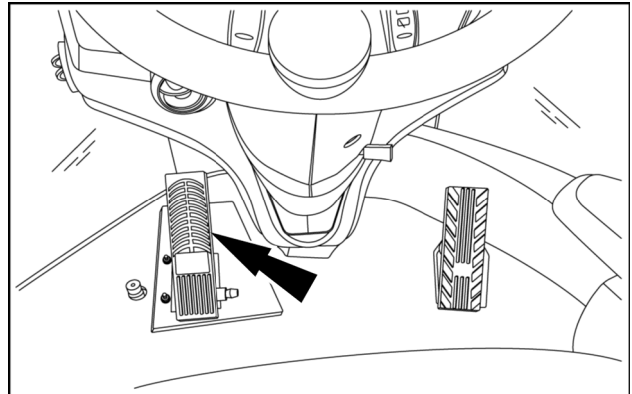

LEIL15WHL0564AA 2

3. Turn the key switch to the ON position. Move the control lever(s) back and forth minimally 30 times to release pressure from the hydraulic circuit. Put the key switch to the OFF position.

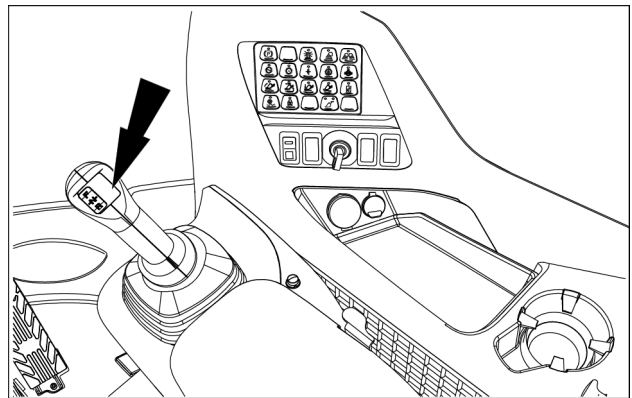

LEIL16WHL1286AA 3

4. Slowly loosen the hydraulic reservoir filler cap to release air pressure in the hydraulic reservoir.

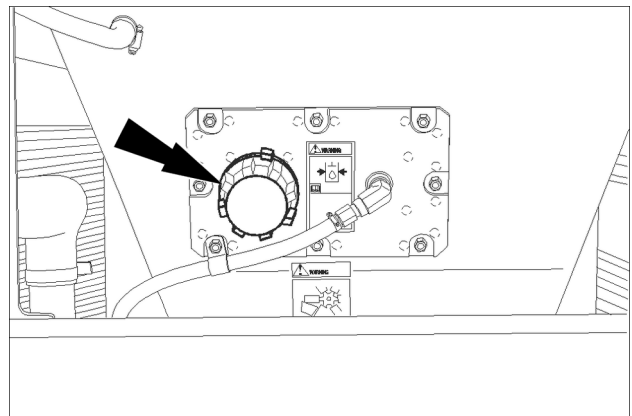

RCPH10WHL099BAL 4

5. Raise the engine hood using the handle hood under the rear grill.

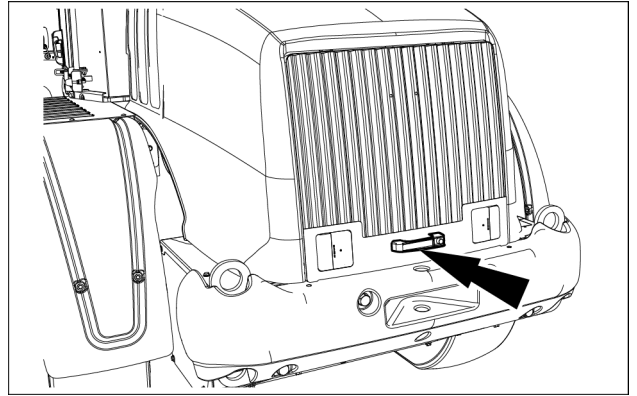

LEIL17WHL0059AB 5

6. Remove the bracket (3) to separate the wide fender (1) from the rear fender (2).

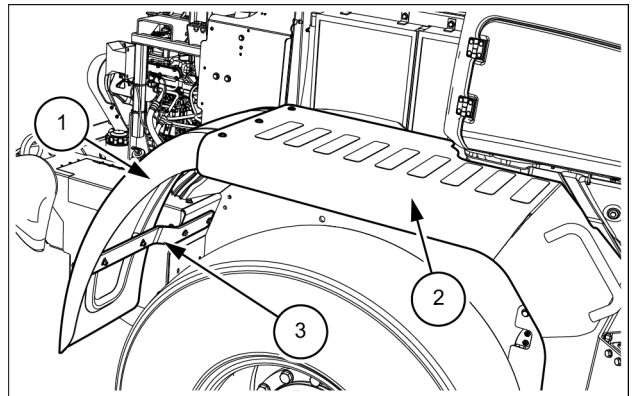

LEIL17WHL0145AB 6

7. Remove the retaining bolts (1) and (2) of the inner fender panel (3).

NOTE: right-hand side of the machine is shown. The operation is similar for the left-hand side.

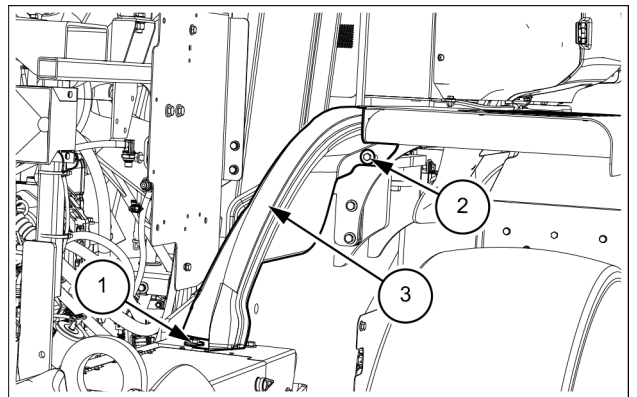

LEIL17WHL0146AB 7

8. Locate the timed disconnect switch under the engine hood, on the left-hand side of the machine. Turn the timed disconnect switch to the OFF position.

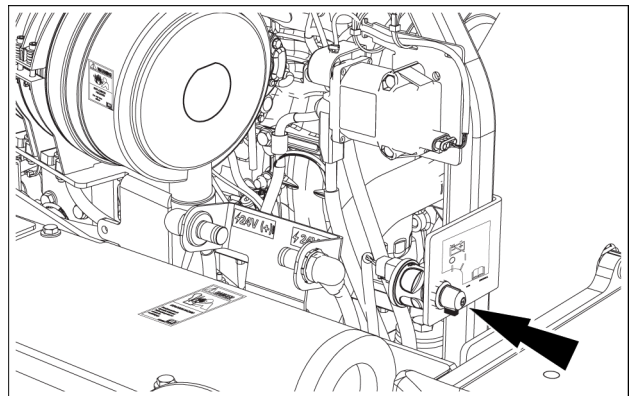

LEIL16WHL2685AA 8

9. Remove the two battery covers. Disconnect the batteries from the machine.

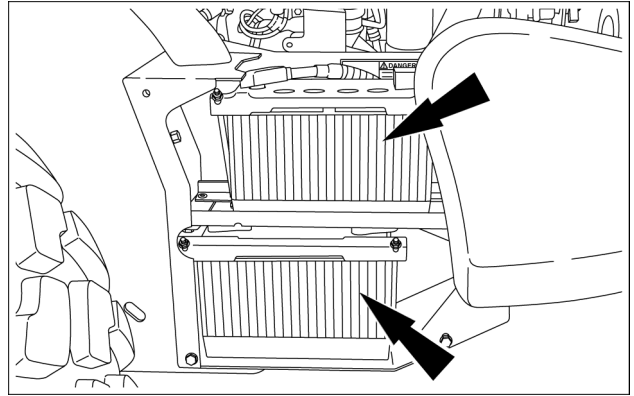

LEIL16WHL1225AA 9

10. Loosen the screw (1) and open the access cover (2) under the battery.

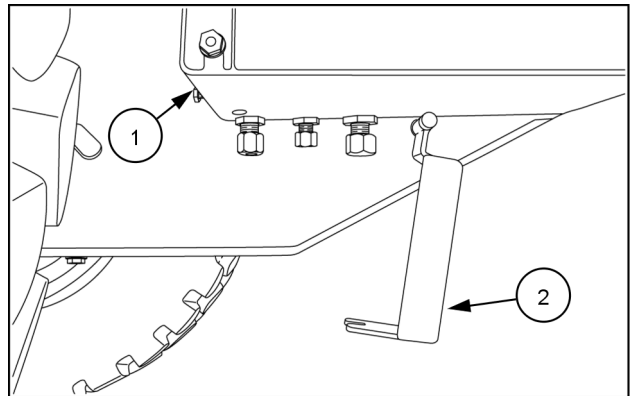

RAPH12WEL1494AA 10

11. Place a suitable container below the radiator drain. Remove the drain plug (1) and radiator cap to drain the engine coolant into the container. then reinstall the radiator cap after the coolant has drained.

NOTE: see machine specifications for cooling system volume.

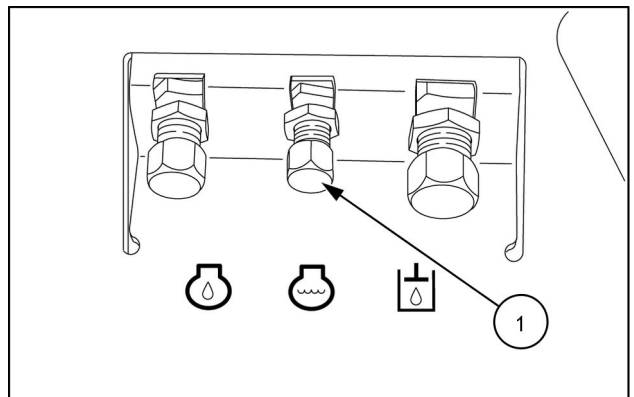

RAPH12WEL1411AA 11

12. Place a suitable container below the engine oil drain. Remove the engine oil cap (2) to drain the engine oil into the container. Then reinstall the engine oil cap after the engine oil has drained.

NOTE: see machine specifications for cooling system volume.

NOTE: after draining the engine oil, disconnect the drain hose from the frame to aid in removal of engine.

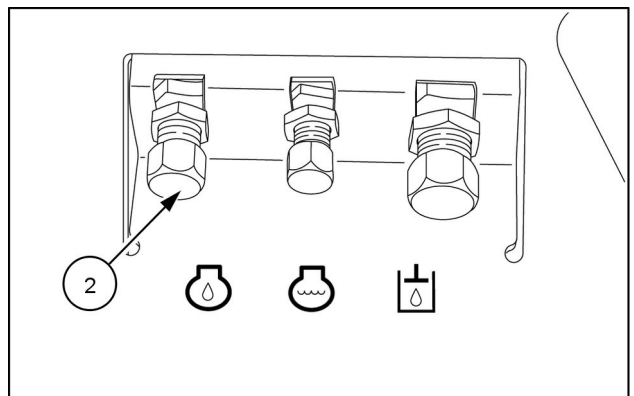

RAPH12WEL1411AA 12

13. Double up a nylon lifting strap and slide the strap through the exhaust stack (1), located on the engine hood.

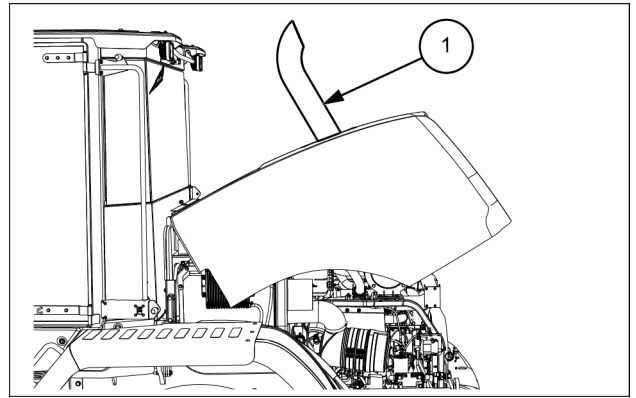

LEIL17WHL0056AB 13

14. Place a solid steel bar through the nylon strap. Raise the engine hood and release the tension on the lifting motor.

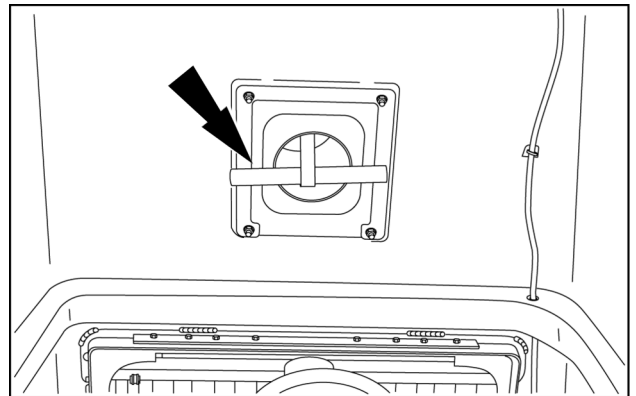

RAPH12WEL1458AA 14

15. Remove the right-hand gas strut from the engine hood.
Remove the left-hand gas strut from the engine hood.

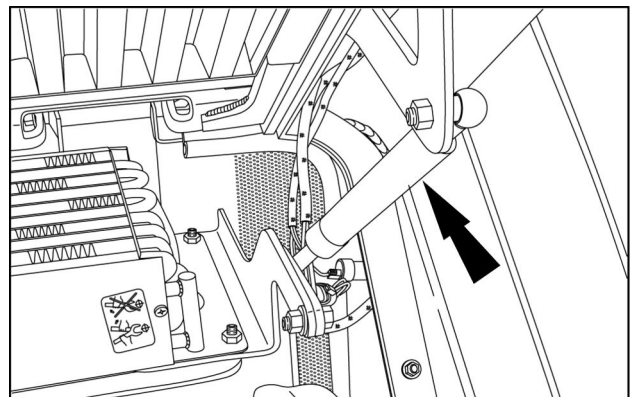

RAPH12WEL1489AA 15

16. Remove the gas spring to separate the engine hood from the rear chassis.

NOTE: engine hood is NOT shown.

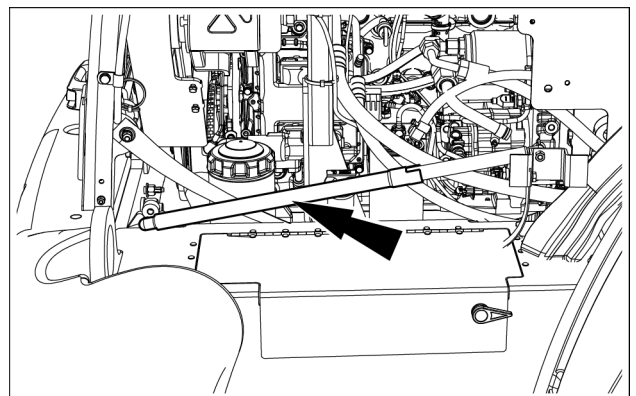

LEIL17WHL0058AB 16



Suggest:

If the above button click is invalid.

Please download this document

first, and then click the above link

to download the complete manual.

Thank you so much for reading

17. Disconnect the hood wiring harness connector from the rear chassis wiring harness connector. Identify and tag the connectors to aid in reassembly.

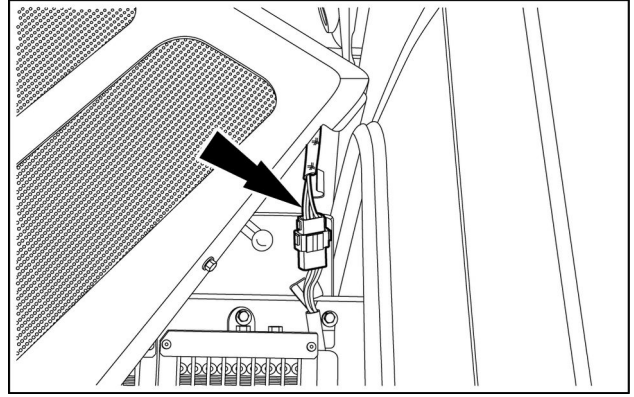

LEIL15WHL0142AB 17

18. Tag and disconnect the backup alarm connector (1). Remove the two straps cable tie (2).

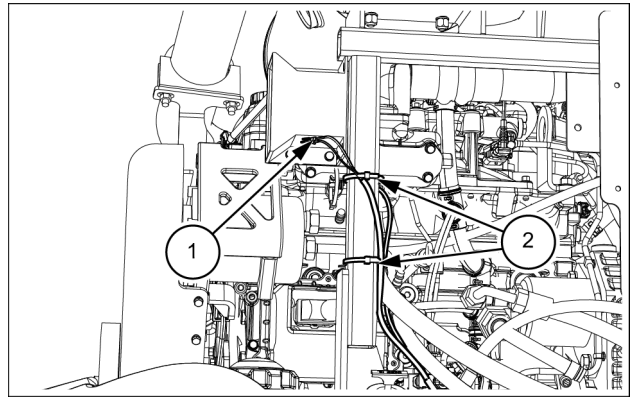

LEIL17WHL0149AB 18

19. Remove the connector (1) from the battery isolator.

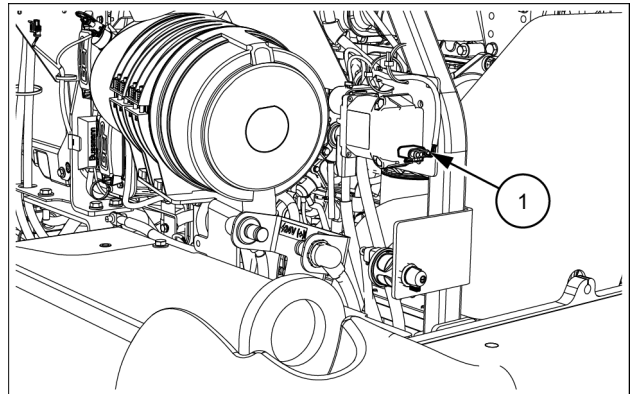

LEIL17WHL0147AB 19

20. Tag and disconnect the battery to isolator cable (1) and the isolator to starter cable (2) from the battery isolator. Disconnect the connector (3) from the timed disconnect switch.

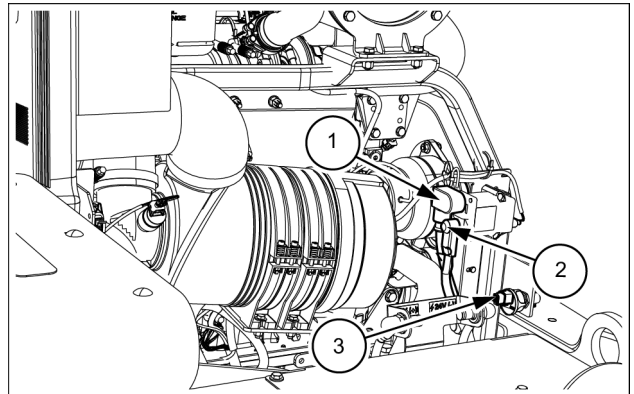

LEIL17WHL0148AB 20

<https://www.ebooklibonline.com>

Hello dear friend!

Thank you very much for reading.

Enter the link into your browser.

The full manual is available for immediate download.

<https://www.ebooklibonline.com>