



W50TC

W60TC

W70TC

W80TC

Repair
manual

Repair manual

Print No. 87618246
English - Printed in Italy

W50TC
W60TC
W70TC
W80TC

TO PREVENT ACCIDENTS

The majority of accidents and injuries which occur in industry, on the farm, at home or on the road, are caused by the failure of some individual to follow simple and fundamental safety rules or precautions. For this reason **MOST ACCIDENTS CAN BE PREVENTED** by recognizing the real cause and taking the necessary precautions, before the accident occurs.

Regardless of the care used in design and construction of any type of equipment, there may be conditions that cannot be completely safeguarded against, without interfering with reasonable accessibility and efficient operation.

A careful operator and / or technician is the best insurance against accidents. The complete observance of one simple rule would prevent many thousands of serious injuries each year.

This rule is: Never attempt to clean, lubricate or adjust a machine while it is in motion.

▲ WARNING

Before carrying out any maintenance operation, adjustment and or repair on machines equipped with attachments, controlled hydraulically or mechanically, make sure that the attachment is lowered and safely set on the ground. If it is necessary to have the equipment partially or fully raised to gain access to certain items, be sure the equipment is suitably supported by means other than

INDEX

SECTION 00 - INTRODUCTION

1. SAFETY INSTRUCTIONS 1
2. TECHNICAL SPECIFICATIONS..... 11

SECTION 10 - ENGINE

1. DIESEL ENGINE 1
2. FUEL SYSTEM 2

SECTION 25 - FRONT AXLES

1. REMOVAL AND INSTALLATION 1
2. DIMENSIONS 3
3. TECHNICAL SPECIFICATIONS..... 4
4. OIL CHANGE AND GREASING 7
5. DISASSEMBLY AND ASSEMBLY..... 8
 5.1 BRAKE DISC ASSY..... 8
 5.2 BRAKE CALIPER 15
 5.3 EPICYCLIC REDUCTION GEAR ASSY (W50TC) 23
 5.4 EPICYCLIC REDUCTION GEAR ASSY (W60TC, W70TC, W80TC)..... 27
 5.5 WHEEL HUB ASSY (W50TC) 31
 5.6 WHEEL HUB ASSY (W60TC, W70TC, W80TC)..... 40
 5.7 WHEEL SHAFT ASSY (W60TC, W70TC, W80TC)..... 46
 5.8 BRAKE AND WHEEL SHAFT ASSY (W60TC, W70TC, W80TC HIGH SPEED)..... 50
 5.9 DIFFERENTIAL SUPPORT ASSY 58
 5.10 DIFFERENTIAL ASSY..... 66
 5.11 PINION ASSY 73
6. TROUBLESHOOTING 80
7. SPECIAL TOOLS..... 83

SECTION 27 - REAR AXLES

1. REMOVAL AND INSTALLATION 1
2. DIMENSIONS 3
3. TECHNICAL SPECIFICATIONS..... 7
4. OIL CHANGE AND GREASING 13
5. DISASSEMBLY AND ASSEMBLY..... 14
 5.1 HYDRAULIC MOTOR ASSY TB150..... 14
 5.2 HYDRAULIC MOTOR ASSY TB138.5 HIGH SPEED 17
 5.3 TRANSMISSION BOX ASSY TB150..... 21
 5.4 TRANSMISSION BOX ASSY TB138.5 HIGH SPEED..... 30
 5.5 EPICYCLIC REDUCTION GEAR ASSY (W50TC) 51
 5.6 EPICYCLIC REDUCTION GEAR ASSY (W60TC, W70TC, W80TC)..... 55
 5.7 WHEEL HUB ASSY (W50TC) 59
 5.8 WHEEL HUB ASSY (W60TC, W70TC, W80TC)..... 68

5.9 WHEEL SHAFT ASSY (W60TC, W70TC, W80TC).....	74
5.10 DIFFERENTIAL SUPPORT ASSY.....	78
5.11 DIFFERENTIAL ASSY.....	87
5.12 LIMITED SLIP DIFFERENTIAL ASSY.....	94
5.13 PINION ASSY.....	101
6. TROUBLESHOOTING.....	108
7. SPECIAL TOOLS.....	112

SECTION 33 - BRAKES SYSTEM

1. BRAKES SYSTEM DIAGRAM.....	1
2. OPERATION.....	2
2.1 SERVICE BRAKE.....	4
2.2 PARKING BRAKE.....	6
3. BRAKE PEDAL VALVE.....	7
3.1 ADJUSTMENTS.....	10
3.2 TROUBLESHOOTING.....	13
4. ACCUMULATORS.....	14
4.1 BRAKE ACCUMULATOR.....	14
4.2 PUMP ACCUMULATOR.....	15
4.3 MAINTENANCE.....	16
5. TROUBLESHOOTING.....	18

SECTION 35 - HYDRAULIC SYSTEM

1. HYDRAULIC DIAGRAMS.....	1
1.1 W50TC HYDRAULIC DIAGRAM.....	1
1.2 W50TC HYDRAULIC DIAGRAM WITH OPTIONAL OUTFITS.....	3
1.3 W60TC HYDRAULIC DIAGRAM.....	5
1.4 W60TC HYDRAULIC DIAGRAM WITH OPTIONAL OUTFITS.....	7
1.5 W70TC BASIC MODEL HYDRAULIC DIAGRAM.....	9
1.6 W70TC HYDRAULIC DIAGRAM WITH OPTIONAL OUTFITS.....	11
1.7 W80TC HYDRAULIC DIAGRAM.....	13
1.8 W80TC HYDRAULIC DIAGRAM WITH OPTIONAL OUTFITS.....	15
2. TRANSMISSION HYDRAULIC SYSTEM.....	17
3. PISTON PUMP AT VARIABLE DISPLACEMENT.....	24
4. GEAR PUMP.....	60
5. PRIORITY VALVE.....	65
6. HYDRAULIC MOTOR.....	66
7. ONE-WAY DISTRIBUTOR VALVE.....	85
8. HYDRAULIC OIL TANK.....	86
9. TROUBLESHOOTING.....	88

SECTION 39 - FRAME

1. ARTICULATED JOINT.....	1
---------------------------	---

<https://www.ebooklibonline.com>

Hello dear friend!

Thank you very much for reading.

Enter the link into your browser.

The full manual is available for immediate download.

<https://www.ebooklibonline.com>

SECTION 41 - STEERING SYSTEM

- 1. STEERING SYSTEM DIAGRAM 1
- 2. OPERATION 2
- 3. ADJUSTMENTS 3
- 4. POWER STEERING 4
 - 4.1 TECHNICAL SPECIFICATIONS..... 5
 - 4.2 HYDRAULIC DIAGRAM 5
 - 4.3 COMPONENTS 6
 - 4.4 DISASSEMBLY AND ASSEMBLY..... 7
 - 4.5 TROUBLESHOOTING..... 24
 - 4.6 SPECIAL TOOLS..... 25
- 5. STEERING CYLINDER 26
 - 5.1 REMOVAL AND INSTALLATION 27
 - 5.2 DISASSEMBLY..... 29
- 6. TROUBLESHOOTING 34

SECTION 50 - HEATING AND AIR CONDITIONING SYSTEM

- 1. HEATING 1
- 2. AIR CONDITIONING 3
- 3. TROUBLESHOOTING 30

SECTION 55 - ELECTRICAL SYSTEM

- 1. ELECTRICAL DIAGRAMS..... 1
- 2. FUSES AND RELAYS 16
- 3. VOLTAGE AND CONTINUITY CHECK..... 18
- 4. BATTERY 19
- 5. BULBS 22
- 6. TROUBLESHOOTING 26

SECTION 82 - WORKING EQUIPMENT

- 1. HYDRAULIC DIAGRAM 2
- 2. OPERATION 3
- 3. REMOVAL AND INSTALLATION 4
- 4. QUICK TOOL COUPLER 6
- 5. BUCKET 10
- 6. LIFTING FORKS 14
- 7. CYLINDERS 18
- 8. CONTROL VALVE 26
- 9. LOAD HOLDING VALVE 29
- 10. TROUBLESHOOTING 30

SECTION 00 - INTRODUCTION

1. SAFETY INSTRUCTIONS	1
2. TECHNICAL SPECIFICATIONS.....	11

1. SAFETY INSTRUCTIONS

Carefully read the safety rules contained herein and follow advised precautions to avoid potential hazards and to safeguard your safety and personal integrity.

In this manual you will find the following indications:

⚠ WARNING

This symbol warns about the possibility of potential damages to the machine that can involve the operator's safety.

⚠ DANGER

With specific warnings about potential dangers for the operator's or other persons integrity directly or indirectly involved.

The non compliance with the warning preceded by the above mentioned key-words (**WARNING** and **DANGER**) can cause serious accidents or even the death of the persons involved.

Moreover in the present Manual have been given some instructions with texts in italics, preceded by the words **NOTE** and **CAUTION**, with following meanings for machine protection:

NOTES: it emphasizes and underlines to the operator the correct technique or correct procedure to follow.

⚠ WARNING

It warns the operator of a possible hazard of machine damage in case he does not follow a determined procedure.

Your safety and that of people around you depends on you. It is essential that you understand this manual for the correct operation, inspection, lubrication and maintenance of this machine.



1.1 GENERAL SAFETY INSTRUCTIONS

Carefully read this Manual before proceeding with maintenance, repairs, refuelling or other machine operations.

Repairs have to be carried out only by authorized and instructed staff; specific precautions have to be taken when grinding, welding or when using mallets or heavy hammers.

Not authorized persons are not allowed to repair or carry out maintenance on this machine. Do not carry out any work on the equipment without prior authorisation.

Ask your employer about the safety instructions in force and safety equipment.

Nobody is allowed to seat on the operator's place during machine maintenance unless he is a qualified operator helping with the maintenance work.

If it is necessary to move the equipment to carry out repairs or maintenance, do not lift or lower the equipment from any other position than the operator's seat.

Never carry out any operation on the machine when the engine is running, except when specifically indicated.

Stop the engine and ensure that all pressure is relieved from hydraulic circuits before removing caps, covers, valves, etc.

All repair and maintenance operations should be carried out with the greatest care and attention.

Service stairs and platforms used in a workshop or in the field should be built in compliance with the safety rules in force.

Any functional disorders, especially those affecting the safety of the machine, should therefore be rectified immediately.

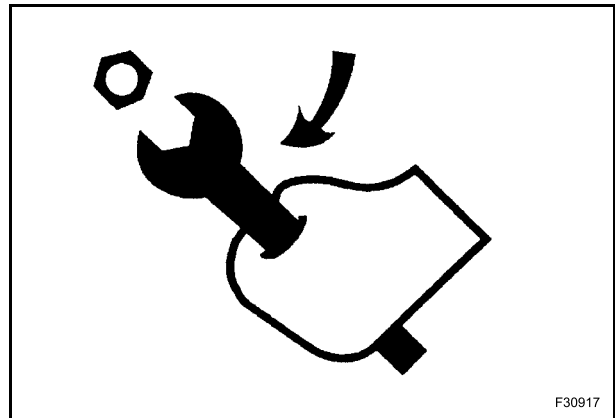

1.2 EMERGENCY

Be prepared for emergencies. Always keep at disposal on the machine a first aid kit and a fire extinguisher. Make sure that the fire extinguisher is serviced in accordance with the manufacturer's instructions.

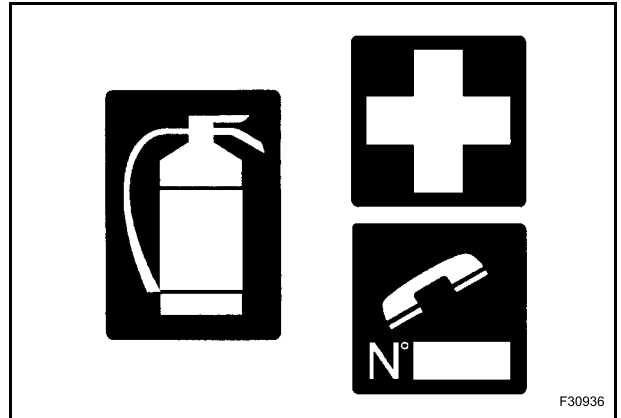

1.3 EQUIPMENT

Wear close fitting clothing and safety equipment appropriate for the job:

- safety helmet;
- safety shoes;
- heavy gloves;
- reflective clothing;
- wet weather clothing.

If environment condition require it following personal safety equipment should be at hand:

- respirators (or dustproof masks);
- ear plugs or acoustic ears protections;
- goggles with lateral shield or masks for eyes protection.

Do not wear rings, wristwatches, jewels, unbuttoned or flapping clothing such as ties, torn clothes, scarves, open jackets or shirts with open zips which could get caught into moving parts.

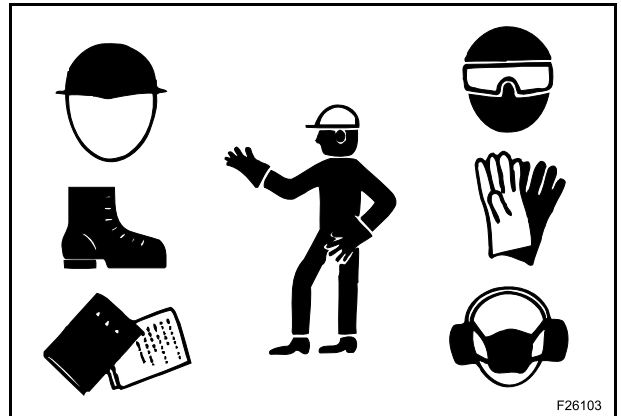

1.4 WHEEL LOADER POSITION

Before carrying out any maintenance on this machine, proceed in the following manner:

- park the machine on a flat, hard ground;
- lower the wheel loader bucket until it rests on the ground;
- shut off the engine and remove the ignition key;
- apply the parking brake;
- block the wheels to prevent any machine movement.

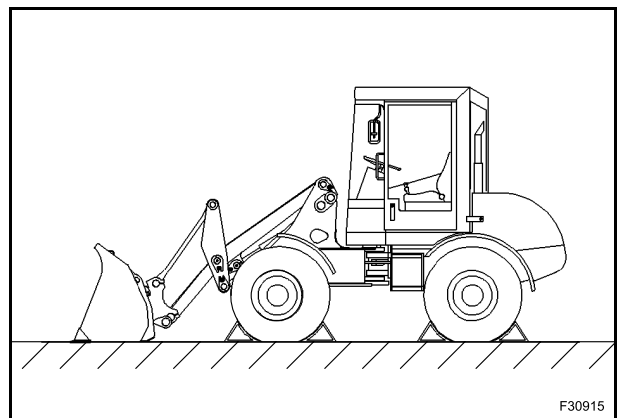

1.5 ENGINE - RADIATOR

Never leave the engine run in closed spaces without ventilation and not able to evacuate toxic exhaust gases. Keep the exhaust manifold and tube free from combustion materials.

Do not keep the engine running during refuelling and pay particular attention if the engine is hot because of the risen hazard of fire in case of fuel spilling.

Never attempt to check or adjust the fan belts when the engine is running.

Never lubricate the machine with the engine running.

Pay attention to rotary pieces and do not allow to anyone to approach to avoid becoming entangled.

If hands, clothes or tools get caught in the fan blades or in the transmission belt, this can cause amputations, violent tears and generate condition of serious danger; for this reason avoid touching or to come close to all rotary or moving parts.

A violent jet of the coolant from the radiator can cause damages and scalds.

If you are to check the coolant level, you have to shut off the engine previously and to let cool down the radiator and its pipes. Slowly unscrew the cap to release the inside pressure.

If necessary, remove the cap with hot engine, wear safety clothes and equipment, then loosen the cap slowly to relieve the pressure gradually.

When checking the fuel, oil and coolant levels, use exclusively explosion proof classified lamps. If this kind of lamps are not used fires or explosions may occur.

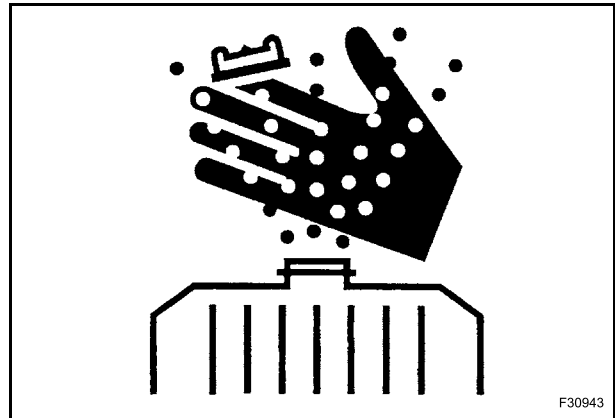
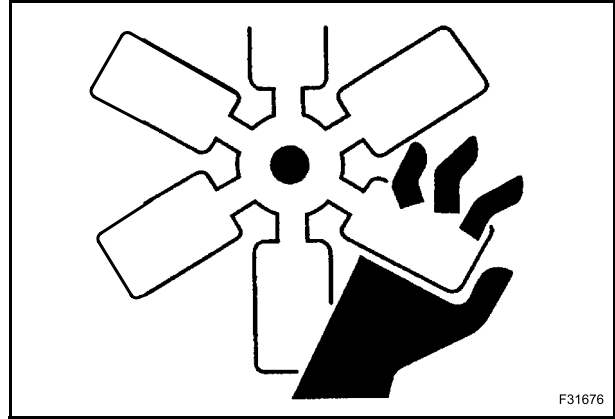

1.6 HYDRAULIC SYSTEMS

Splashes of fluids under pressure can penetrate the skin causing serious injuries.

Avoid this kind of danger by releasing the pressure before disconnecting the hydraulic hoses or other lines.

Release the residual pressure by moving the control levers several times.

Tighten all connections before applying pressure.

To protect eyes wear a facial shield or safety goggles.

Look for possible leaks with a piece of cardboard.

Protect your hands and body from possible splashes of fluids under pressure.

In case of accident ask for appropriate medical help urgently.

Any fluid penetrating the skin must be removed within few hours to avoid serious infections.

Flammable splashes may originate because of the heat near pipes with fluids under pressure, with the result of serious scalds for the persons hit.

Do not weld or use torches near pipes containing fluids or other flammable materials.

Pipes under pressure can accidentally be pierced when the heat expands beyond the area immediately heated.

Arrange for fire resistant temporary shields to protect hoses or other components during welding, etc.

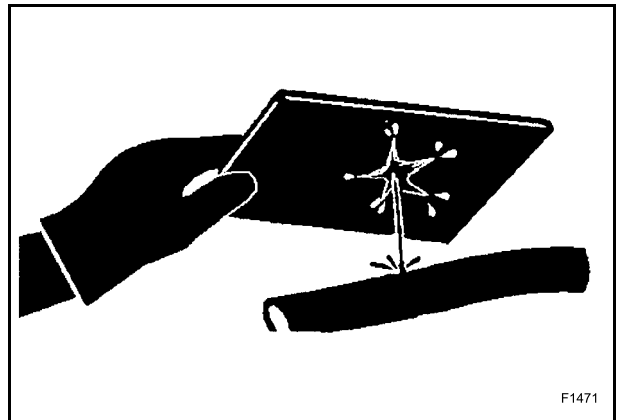

HOSES AND TUBES

Always replace hoses and tubes if the cone end or the end connections on the hose are damaged.

When installing a new hose, loosely connect each end and make sure the hose takes up the designed position before tightening the connections. Clamps should be tightened sufficiently to hold the hose without crushing and to prevent chafing.

After hose replacement to a moving component, check that the hose does not foul by moving the component through the complete range of travel.

Be sure any hose which has been installed is not kinked or twisted.

Hose connections which are damaged, dented, crushed or leaking, restrict oil flow and the productivity of the components being served. Connectors which show signs of movement from the original position have failed and will ultimately separate completely.

A hose with a frayed outer sheath will allow the water penetration. Concealed corrosion of the wire reinforcement will subsequently occur along the hose length with resultant hose failure.

Swelling of the hose indicates an internal leakage due to structural failure. This condition rapidly deteriorates and total hose failure soon occurs.

Kinked, crushed, stretched or deformed hoses generally suffer internal structural damage which can result in oil flow restriction, a speed reduction of operation and ultimate hose failure.

Free-moving, unsupported hoses must never be allowed to touch each other or related working surfaces. This causes chafing which reduces hose life.

O-RING

Replace O-rings, seal rings and gaskets whenever they are disassembled.

Never mix new and old O-rings or seal rings, regardless of condition. Always lubricate new seal rings and O-rings with hydraulic oil before installation to relevant seats.

This will prevent the O-rings from rolling over and twisting during assembly which will jeopardize sealing.

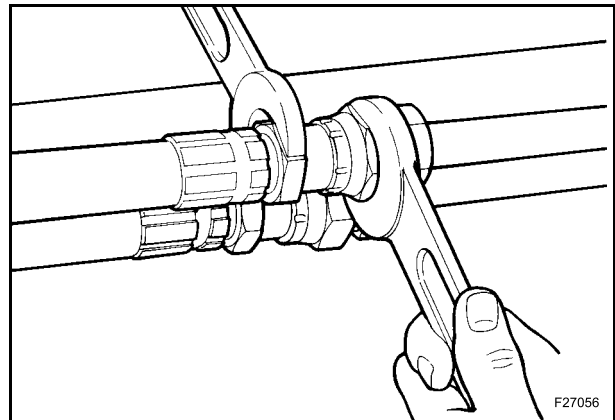

1.7 BATTERY

A spark or flame can cause the hydrogen in the battery to explode. To prevent any risk of explosion, observe the following instructions:

- when disconnecting the battery cables, always disconnect the negative (-) cable first;
- to reconnect the battery cables, always connect the negative (-) cable last;
- never short-circuit the battery clamps with metal objects;
- do not weld, grind or smoke near a battery.

Battery electrolyte causes severe burns. The battery contains sulphuric acid. Avoid any contact with the skin, eyes or clothing.

Antidote:

- EXTERNAL: rinse well with water, removing any soiled clothing.
- INTERNAL: avoid vomiting. Drink water to rinse your mouth. Consult a doctor.
- EYES: rinse abundantly with water for 15 minutes and consult a doctor.
- When the electrolyte of a battery is frozen, it can explode if you attempt to charge the battery or if you try to start the engine using a booster battery. Always keep the battery charged to prevent the electrolyte freezing.

Batteries generate explosive gases. Keep all flames, sparks and cigarettes away. Provide good ventilation when changing a battery or using a battery in an enclosed space. Always protect your eyes when working near a battery.

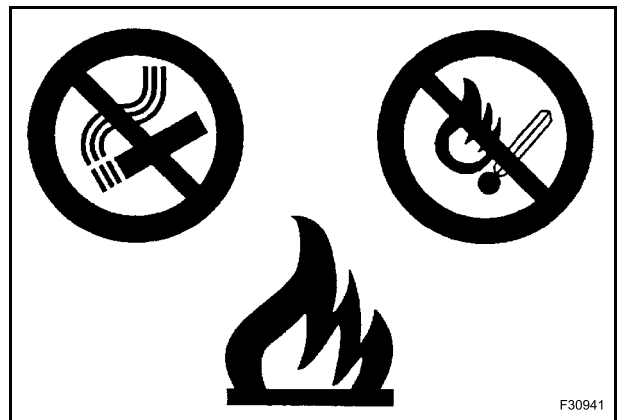
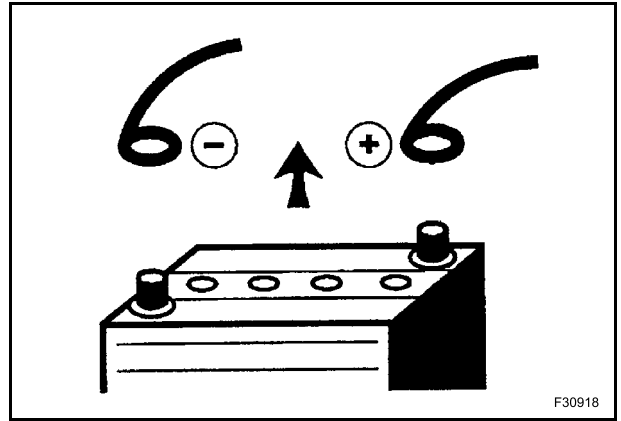

1.8 REFUELLING

Stay away from open flames during refilling of hydraulic oil or fuel.

Fuel or oil splashes can cause slippings and therefore accidents; clean immediately and accurately the areas eventually smeared.

Always tighten the safety plugs of fuel tank and hydraulic oil tank firmly.

Never use fuel to clean the machine parts eventually smeared with oil or dust.

Always perform fuel or oil refilling in well aired and ventilated areas.

Do not smoke during these operations.

During refuelling hold the pistol firmly and keep it always in contact with the filler neck until the end of the refuelling, to avoid sparkles due to static electricity.

Do not overfill the tank but leave a space for fuel expansion.



1.9 TYRES

Before inflating the tyres, always check the condition of rims and the outer condition of tyres to find out the presence of dents, cuts, tears of reinforcement plies or other faults. Before inflating a tyre, make sure that there are no nearby persons, then position yourself at tread side.

Make sure that the inflating pressure of tyres is the same prescribed by manufacturer and check periodically its integrity. Always check that the right tyre pressure corresponds to the pressure of the left tyre. The pressure check must be carried out with machine unloaded and cold.

Never use reconditioned rims because possible welds, heat treatments or brazings not performed correctly can weaken the wheels and cause following damages or failures. Deflate the tyres before their disassembly.

Before taking out possible jammed objects from the rims, it is necessary to deflate the tyres. Inflate tyres by means of a pistol complete with extension and pressure switch of control.

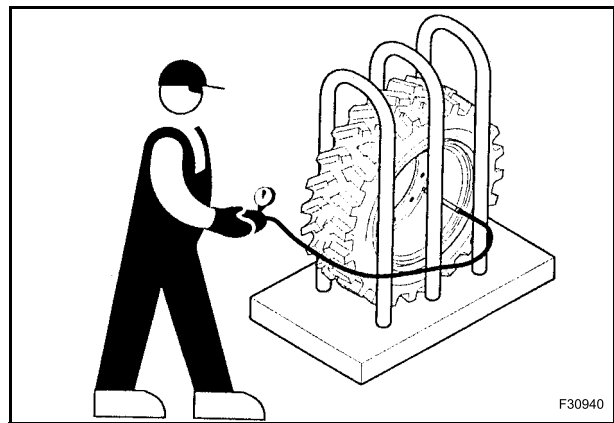

1.10 CLEANING

Clean the exterior of all components before carrying out any form of repair. Dirt and dust can reduce the efficient working life of a component and lead to costly replacement.

Time spent on the preparation and cleanliness of working surfaces will pay dividends in making the job easier and safer and will result in overhauled components being more reliable and efficient in operation. Use cleaning fluids which are known to be safe. Certain types of fluids can damage the O-rings and cause skin irritation.

Check that solvents are suitable for the cleaning of components and that they are no risky for personal safety of the user.

Dirt from oil or grease and scattered tools or faulty pieces are dangerous for persons, because they can generate slipping or falls.

For the machine cleaning, use a jet of warm water or steam under pressure and commercial detergents. Never use diesel fuel, petroleum or solvents, because the first ones leave an oily layer that favours the sticking of dust, while solvents (even if weak) damage the paint and favour the formation of rust.

If a jet of water penetrates into the electric devices, beyond causing oxidation of contacts, it can also prevent the machine start or cause a sudden and abrupt start of the engine. For this reason, never use water jets or steam on sensors, connectors or other electric components.

Avoid that the water jet penetrates inside of the cab.

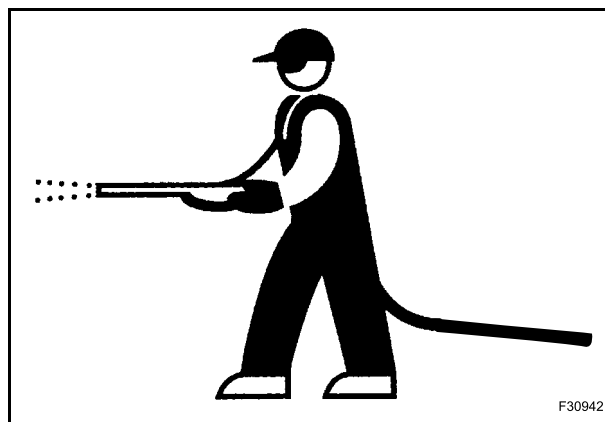

1.11 WASTE DISPOSAL

Improperly disposing of waste can threaten the environment.

Each country has its own Regulations on this subject. It is therefore advisable to prepare suitable containers to collect and store momentarily all solid and fluid materials that must not be scattered in the environment to avoid pollution.

At preset intervals these products will be delivered to disposal stations legally recognized and present in this Country.

Hereunder are listed some products of the machine requiring disposal:

- lube oil;
- brakes system oil;
- coolant mixture, condensation rests and pure anti-freeze;
- diesel oil;
- oil and diesel oil filter elements;
- engine and air conditioning air filter elements;
- battery.

Also polluting rags, paper, sawdust and gloves must be disposed in compliance with the same procedures.

Do not use food or beverage containers that may mislead someone into drinking from them. Do not pour waste onto the ground, down a drain, or into any water sources. Air conditioning coolants escaping into the air can damage the Earth's atmosphere. Government regulations may require a certified air conditioning service centre to recover and recycle used air conditioning coolants. Obtain information on the proper way to recycle or dispose of waste from your local environmental or recycling centre, or from your Dealer.

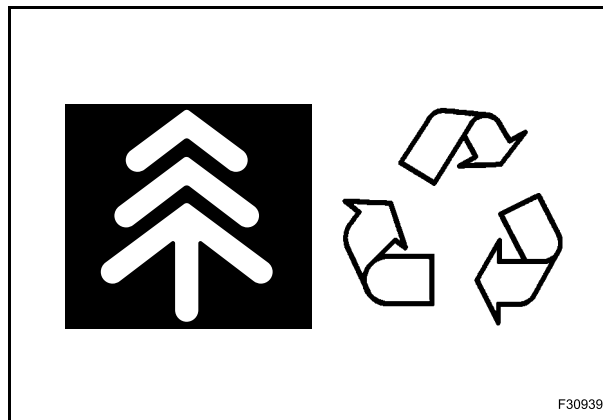



Suggest:

If the above button click is invalid.

Please download this document

first, and then click the above link

to download the complete manual.

Thank you so much for reading

2. TECHNICAL SPECIFICATIONS

2.1 MAIN COMPONENTS

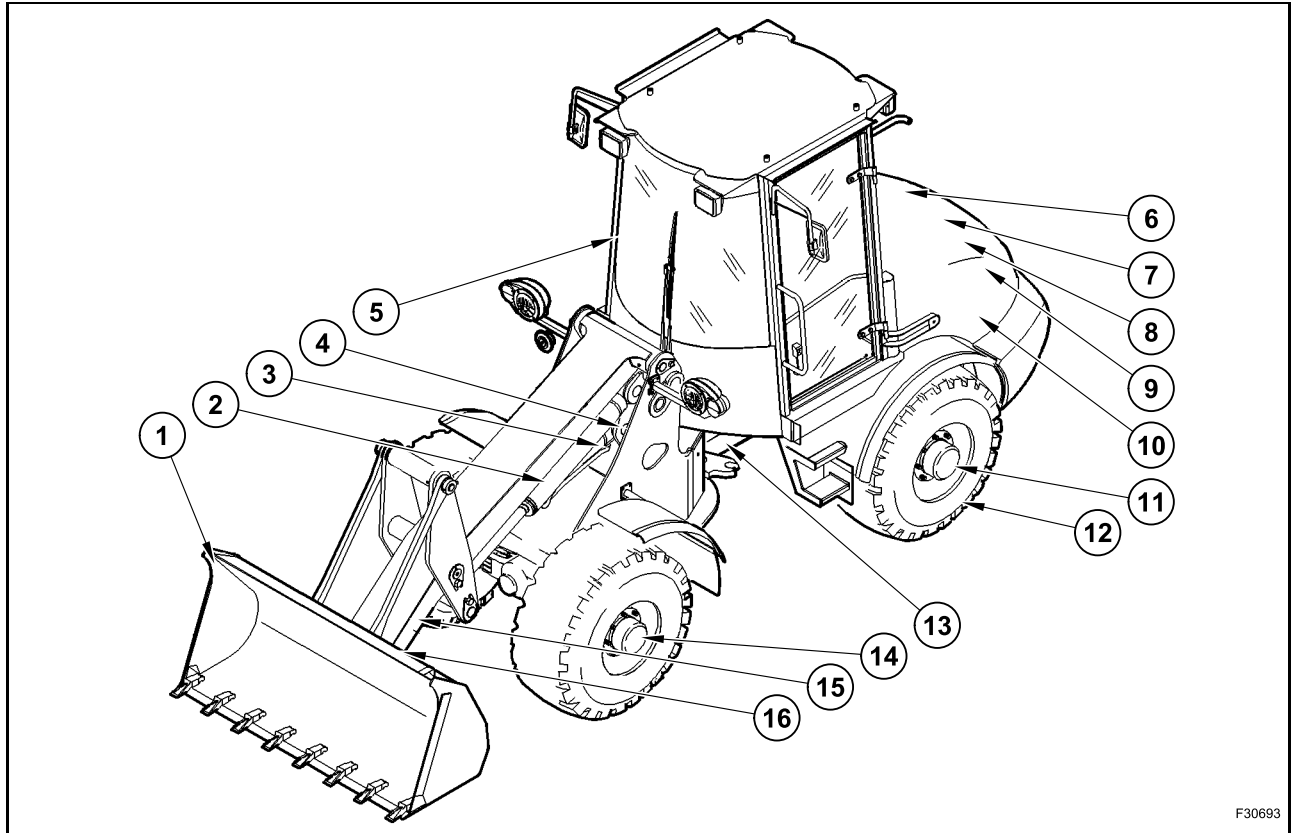

- | | |
|------------------------|---------------------------|
| 1. Wheel loader bucket | 9. Hydraulic pumps |
| 2. Dumping cylinder | 10. Battery |
| 3. Lifting cylinder | 11. Rear axle |
| 4. Fuel tank | 12. Transmission |
| 5. Cab | 13. Steering cylinder |
| 6. Hydraulic oil tank | 14. Front axle |
| 7. Air filter | 15. Working equipment arm |
| 8. Diesel engine | 16. Quick tool coupler |

<https://www.ebooklibonline.com>

Hello dear friend!

Thank you very much for reading.

Enter the link into your browser.

The full manual is available for immediate download.

<https://www.ebooklibonline.com>