

TVT 135, TVT 145, TVT 155, TVT 170, TVT 190, TVT 195 Tractors

Service - Manual Sva 6035448106

Table of Contents Volume 1 - 3

Section Pub. No.

TABLE OF CONTENTS - VOLUME 1

2 ENGINE		
Workshop Manual.....	2002	6-51250
Workshop Manual (TVT 195)	2002A	6-93080
3 FUEL SYSTEM		
Functional description Injection System	3001	6-51300
Functional description Injection System - Common Rail System (TVT 195)	3001A	6-93150
4 ELECTRICAL		
Functional description CAN Bus (Basics)	4002	6-51350
Functional description and Troubleshooting – ADIC	4003	6-91700
Function diagrams - Electrics	4008	6-92771
Function diagrams - Electrics (TVT 195)	4008A	6-93221
Connectors, Wiring Harnesses, Electrical and Electronic Components	4009	6-92970
Connectors, Wiring Harnesses, Electrical and Electronic Components (TVT 195) ..	4009A	6-93290
Circuit diagram	4010	6-51402
Circuit diagram (TVT 195)	4010A	6-93360

TABLE OF CONTENTS - VOLUME 2

4 ELECTRICAL		
Fault codes	4011	6-52632

TABLE OF CONTENTS - VOLUME 3

5 STEERING SYSTEM		
Functional description, Troubleshooting and Settings		
Front Axle with Independent Suspension 20.25S.....	5001	6-51450
Functional description, Troubleshooting and Settings		
Front Axle with Independent Suspension 20.29S.....	5002	6-51500
Workshop Manual - Front Axle - Carraro 20.25, 20.25 FR	5005	6-51550
Workshop Manual - Independently Suspended Front Axle 20.25S and 20.25SI FR.....	5006	6-51600
Workshop Manual - Independently Suspended Front Axle 20.29SI / FR	5007	6-51651
6 TRANSMISSION		
Functional description Transmission	6001	6-51700
Troubleshooting - System hydraulics	6002	6-51750
Cartridge - Removing and Fitting.....	6005	6-51800
Cartridge - Disassembling and Assembling.....	6006	6-51850
Rear Axle - Removing and Fitting.....	6007	6-51900
Rear Axle - Disassembling and Assembling.....	6008	6-51950
Parking Interlock, 4-wheel Drive Clutch and Bevel Pinion (Rear Module).....	6009	6-52000

8 HYDRAULIC SYSTEM

Functional description CC-LS Hydraulic System (Closed Center-Load Sensing)....	8001	6-52051
Functional description and troubleshooting		
High Pressure Hydraulic Circuit.....	8002	6-92610
Functional description and troubleshooting		
(Electronic 3-point hitch control system EDC)	8005	6-52100
Fault codes and fault description, EHS Auxiliary Control Units	8006	6-52150

9 CABIN

Functional description and troubleshooting Air Conditioning.....	9002	6-92840
--	------	---------

Chapter

2002

ENGINE WORKSHOP MANUAL

2002

<https://www.ebooklibonline.com>

Hello dear friend!

Thank you very much for reading.

Enter the link into your browser.

The full manual is available for immediate download.

<https://www.ebooklibonline.com>

TABLE OF CONTENTS

SPECIAL TOOLS	5
FOR THE USER	7
Engine code and serial number	7
SAFETY REGULATIONS	8
ENGINE DATA	9
Lifting the engine	9
TECHNICAL DATA	10
Conformance with exhaust standards	10
Cylinder block	10
Cylinder liners	10
Cylinder head	10
Valves, rocker arms and push rods	11
Camshaft	12
Crankshaft	12
Flywheel	13
Gear drive, camshaft and injection pump	13
Con-rods	13
Pistons, piston rings and piston pins	14
Lubrication system	14
Lubrication oil pump	15
Thermostat	15
Coolant temperature indication and monitoring (signal from sensor B22)	15
Coolant pump	15
Schwitzer turbocharger S200	15
Tightening torques	16
CONSTRUCTION	17
General	17
Cylinder block	17
Flywheel casing	17
Cylinder head	18
Valve mechanism	18
Crankshaft drive	20
Timing gears	21
Lubrication system	22
Cooling system	23
Fan	24
Intake/exhaust system	25

ELECTRONIC ENGINE CONTROL SYSTEM – EEM2	26
Layout	27
Signals	28
Function	28
JOB INSTRUCTIONS	29
1. Cylinder block	29
A. Measuring the cylinder liner wear	29
B. Removing the cylinder liner	29
C. Checking the cylinder block	29
D. Replacing the camshaft bearing bush	29
E. Oversize bearing bushes for the camshaft	30
F. Fitting the plug at the rear camshaft end	31
G. Fitting the plug at the rear camshaft end after inserting an oversize bearing bush ..	31
H. Installing the oil dipstick tube	31
I. Fitting the cylinder liner	31
2. Flywheel casing	33
A. Fitting the flywheel casing	33
B. Replacing the rear crankshaft sealing ring	33
3. Cylinder head	34
A. Removing the cylinder head	34
B. Removing the valves	34
C. Checking the cylinder head	34
D. Replacing the valve guides	35
E. Machining the valve seat	36
F. Replacing the valve seat rings	36
G. Grinding the valves	36
H. Fitting the valves	37
I. Fitting the cylinder head	37
4. Valve mechanism	38
A. Maintenance of the rocker arm system	38
B. Replacing the camshaft/camshaft gear wheel	38
C. Checking and adjusting the valve clearance	39
5. Crankshaft	40
A. Removing the crankshaft	40
B. Checking the crankshaft	40
C. Replacing the crankshaft gear wheels	40
D. Fitting the crankshaft	41
E. Crankshaft hub	41
F. Replacing the crankshaft belt pulley and the vibration damper	42
G. Checking the rubber element in the vibration damper	42
6. Pistons and con-rods	43
A. Removing the pistons together with the con-rods	43
B. Checking and replacing the con-rod bearings	43
C. Checking the con-rod	43
D. Checking and replacing the piston rings	44
E. Checking the pistons	45
F. Fitting the piston pin	45
G. Fitting the pistons and con-rods	45

7. Flywheel	46
A. Replacing the starter ring gear on the flywheel	46
B. Fitting the flywheel	46
8. Timing mechanism	47
A. Removing the timing gear case	47
B. Replacing the intermediate gear wheel bearing bush	47
C. Fitting the timing gear case	48
9. Lubrication system	50
A. Checking the oil pressure valve	50
B. Removing and checking the oil pump	50
C. Assembling and fitting the oil pump	50
D. Fitting the sump	51
E. Oil cooler	51
F. Piston cooling nozzles	52
G. Recommended lubrication oils	52
10. Cooling system	53
A. Thermostat	53
B. Repairing the coolant pump	53
C. Coolant quality requirements	54
11. Intake/exhaust system	55
A. Checking the air filter	55
B. Checking the intake/exhaust system	55
C. Checking the boost pressure	55
D. Checking the turbocharger	56
E. Fitting the turbocharger	57

ENGINE DATA

Engine type	620.95	620.96	620.97	620.98	620.99
Number of cylinders	6				
Capacity (dm ³)	6,6				
Bore (mm)	108				
Stroke (mm)	120				
Rated power in PS at 2100 rpm acc. to ISO 14396	135	145	155	170	190
Delivery start mark on the V-belt pulley (° before UDC)	30				
Compression ratio	18,5 : 1		18,5 : 1		
Method of combustion	direct injection				
Injection sequence	1 - 5 - 3 - 6 - 2 - 4				
Compression pressure ¹ (bar)	24				
Charge-air pressure ² (bar)	0,94	1,03	1,12	1,24	1,45
Weight ³ (kg)	510				
Direction of rotation of the crankshaft	Clockwise				

1) Minimum value at operating temperature and starter speed.

Highest permissible difference between the cylinders is 3 bar (max.)

2) Measured behind the charge-air cooler (measuring point: see section entitled "Checking the boost pressure" page 55), at full load, nominal engine speed and top fan speed

3) Without flywheel and electrical equipment.

IMPORTANT: After certain repairs to the engine, the fuel system must be bled before starting for the first time (for details, refer to Chapter 3001, Injection system).

NOTE: The plug-in connection on the PCU must be released and disconnected before performing any arc welding work. **Do not touch the plug-in contacts!**

Lifting the engine



The engine is lifted safely by means of a lifting device, on which the lifting force acts vertically on the lifting eyes.

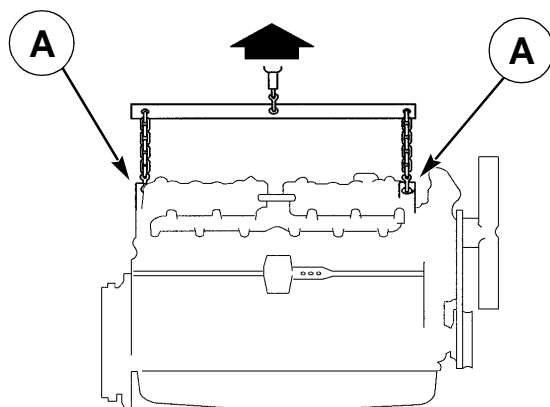

A = Engine lifting eyes

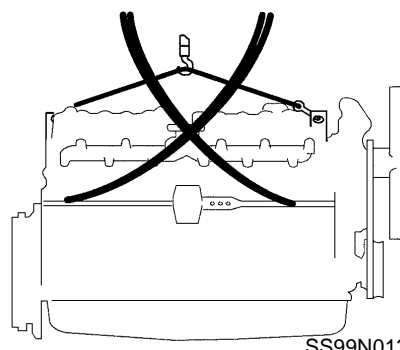

TECHNICAL DATA

Conformance with exhaust standards

Europe: 97/68 EC Level 2

America: Tier 2

Cylinder block

Guide pin bore holes	13.250 - 13.320 mm
Diameter of the crankshaft bearing base bore hole	91.000 - 91.025 mm
Diameter of the crankshaft bearing base bore hole (oversize)	92.000 - 92.025 mm
Bore hole diameter of the cylinder liner:	
– top	124.514 - 124.554 mm
– bottom	123.000 - 123.040 mm
Diameter of the camshaft bearing bush (fitted)	50.010 - 50.070 mm
Construction height of the cylinder block	428.170 - 428.430 mm

Cylinder liners

Liner height above the cylinder block	0.030 - 0.080 mm
Highest permissible height difference between cylinder liners	0.02 mm
Diameter of the cylinder liner bore holes in the engine block:	
– top end of liner	124.475 - 124.500 mm
– bottom end of liner	122.961 - 122.986 mm
Cylinder liner bore hole	108.010 - 108.032 mm
Height, cylinder liner flange	9.03 - 9.05 mm
Height, cylinder liner flange, 1st oversize	9.08 - 9.10 mm
Height, cylinder liner flange, 2nd oversize	9.13 - 9.15 mm
Height, cylinder liner flange, 3rd oversize	9.23 - 9.25 mm
Outer diameter of the cylinder liner flange	131.700 - 131.800 mm

Cylinder head

Construction height of the cylinder head	104.800 - 105.000 mm
Minimum height of the cylinder head after surface grinding	104.000 mm
Inner diameter of the valve guide (when not fitted)	9.000 - 9.015 mm
Outer diameter of the valve guide	16.028 - 16.039 mm
Diameter of the bore hole for the valve guide in the cylinder head	16.000 - 16.018 mm
Projection of the valve guide over the cylinder head face	
– Inlet valve	0.7 ± 0.05 mm (max. 2,20 mm)
– Outlet valve	0.6 ± 0.05 mm (max. 2,20 mm)
Valve seat angle:	
– Inlet valve	35°+20'
– Outlet valve	45°+20'
Valve seat width:	
– Inlet valve	2.9 - 3.7 mm
– Outlet valve	1.3 - 2.3 mm
Diameter, outlet valve seat insert (standard)	44.070 - 44.132 mm
Bore hole in cylinder head for outlet valve seat insert (standard)	44.000 - 44.025 mm
Diameter, outlet valve seat insert (oversize)	44.270 - 44.332 mm
Bore hole in cylinder head for outlet valve seat insert (oversize)	44.200 - 44.225 mm
Diameter, inlet valve seat insert (standard)	48.570 - 48.632 mm
Bore hole in cylinder head for inlet valve seat insert (standard)	48.500 - 48.525 mm
Diameter, inlet valve seat insert (oversize)	48.770 - 48.832 mm
Bore hole in cylinder head for inlet valve seat insert (oversize)	48.700 - 48.725 mm

Valves, rocker arms and push rods

Valve control times at a valve play of 1.0 mm:

– Inlet valve opens	0° ±2° before TDC
– Inlet valve closes	16° ±2° after BDC
– Outlet valve opens	39° ±2° before BDC
– Outlet valve closes	1° ±2° after TDC

Valve play when engine is cold/hot:

– Inlet valve	0.35 mm
– Outlet valve	0.35 mm

Valve head angle:

– Inlet valve	35°-20'
– Outlet valve	45°-20'

Valve head diameter:

– Inlet valve	48 mm
– Outlet valve	41 mm

Maximum opening lift of the valves:

– Inlet valve	10,9 mm
– Outlet valve	12.1 mm

Diameter, inlet valve stem

8.960 - 8.975 mm

Diameter, outlet valve stem

8.925 - 8.940 mm

Clearance, inlet valve stem (guide fitted in cylinder head)

0.025 - 0.055 mm

Wear limit (inlet valve stem)

0.30 mm

Clearance, outlet valve stem (guide fitted in cylinder head)

0.060 - 0.090 mm

Wear limit (outlet valve stem)

0.35 mm

Inner diameter of the valve guide (when not fitted)

9.000 - 9.015 mm

Outer diameter of the valve guide

16.028 - 16.039 mm

Diameter of the bore hole for the valve guide in the cylinder head

16.000 - 16.018 mm

Projection of the valve guide over the cylinder head face

21 mm

Depth, valve head below cylinder head surface:

– Inlet valve

0.7 ± 0.05 mm (max. 2.20 mm)

– Outlet valve

0.6 ± 0.05 mm (max. 2.20 mm)

Length of the valve spring, relaxed

69.8 mm

Force of the valve spring compressed to a length of:

– 48,6 mm

327 ± 17 N

– 37.4 mm

500 ± 23 N

Diameter, rocker arm shaft

22.970 - 22.990 mm

Diameter of rocker arm bore hole

23.000 - 23.021 mm

Permissible radial deflection of the push rod (free)

0.4 mm

Length of the rocker arm spring, relaxed

80 mm

Force of the valve spring compressed to a length of 58 mm

80 - 100 N

Outer diameter of the tappet

29.939 - 29.960 mm

Diameter of the tappet bore holes in the cylinder block

30.000 - 30.043 mm

Camshaft

Diameter, camshaft bearing journal No. 1 (front)	49.925 - 49.950 mm
Diameter, camshaft bearing journals No. 2, 3 and 4	49.865 - 49.890 mm
Diameter, camshaft bearing journal No. 5	49.885 - 49.910 mm
Diameter, camshaft bearing No. 1 (bearing bush fitted).....	50.010 - 50.070 mm
Diameter of the other camshaft bearings (bearing bushes fitted)	50.000 - 50.025 mm
Play, camshaft bearing No. 1	0.060 - 0.145 mm
Play of camshaft bearings No. 2, 3 and 4	0.110 - 0.160 mm
Play, camshaft bearing No. 5	0.090 - 0.140 mm
Overlap of the bearing seats (press fit) in the cylinder block	0.025 - 0.080 mm
Diameter of the bearing seat bore holes in the cylinder block	55.620 - 55.650 mm
Axial play of the camshaft (with a 0.5 mm seal between the cylinder block and timing case and between the timing case and timing case cover)	0.5 - 1.0 mm
Cam height (dimension between cam base circle and cam lobe):	
– Inlet valve	41.180 - 41.430 mm
– Outlet valve	40.080 - 40.330 mm
Cam stroke:	
– Inlet valve	7.38 mm
– Outlet valve	8.28 mm
Max. permissible radial deflection of the camshaft	0.03 mm

Crankshaft

Diameter of the con-rod bearing journals:

– Standard dimension	67.981 - 68.000 mm
– 1st. repair level 0.25 mm	67.731 - 67.750 mm
– 2nd. repair level 0.50 mm	67.481 - 67.500 mm
– 3rd. repair level 1.00 mm	66.981 - 67.000 mm
– 4th. repair level 1.50 mm	66.481 - 66.500 mm
Width of the con-rod bearing journal	40.000 - 40.160 mm

Diameter of the crankshaft journals:

– Standard dimension	84.985 - 85.020 mm
– 1st. repair level 0.25 mm	84.735 - 84.770 mm
– 2nd. repair level 0.50 mm	84.485 - 84.520 mm
– 3rd. repair level 1.00 mm	83.985 - 84.020 mm
– 4th. repair level 1.50 mm	83.485 - 83.520 mm
Diameter, crankshaft bearing casing	91.000 - 91.025 mm

Thickness of the main bearing shells

– Standard dimension	2.955 - 2.965 mm
– 1st. repair level 0.25 mm	3.080 - 3.090 mm
– 2nd. repair level 0.50 mm	3.205 - 3.215 mm
– 3rd. repair level 1.00 mm	3.455 - 3.465 mm
– 4th. repair level 1.50 mm	3.705 - 3.715 mm

Crankshaft bearing play

0.050 - 0.127 mm

Width of the journal at the thrust bearing (crankshaft bearing at flywheel):

– Standard dimension (2 standard thrust washers)	45.000 - 45.080 mm
– 1st. repair level (one standard thrust washer and one with an oversize of 0.1 mm) ..	45.100 - 45.180 mm
– 2nd. repair level (one standard thrust washer and one with an oversize of 0.2 mm) ..	45.200 - 45.280 mm
– 3rd. repair level (one 0.1 mm thrust washer and one with an oversize of 0.2 mm)	45.300 - 45.380 mm
– 4th. repair level (two thrust washers with an oversize of 0.2 mm)	45.400 - 45.480 mm

Other crankshaft bearing journals must not be ground wider.

Axial play of the crankshaft	0.100 - 0.380 mm
Max. permissible out-of-true of the crankshaft or con-rod bearing journals	0.03 mm
Max. permissible imbalance of the crankshaft	1.0 Ncm.

Flywheel

Overlap of the starter ring gear on the flywheel	0.425 - 0.600 mm
Before pressing the starter ring gear onto the flywheel, the ring gear must be heated up to a temperature of	150 - 200 °C
Max. permissible imbalance at the flywheel	1.0 Ncm
Max. permissible warpage of the clutch surface measured at the inner edge of the clutch surface (diameter 200mm)	0.06 mm

Gear drive, camshaft and injection pump

Tooth flank play:

Intermediate gear wheel – crankshaft	0.05 - 0.25 mm
Intermediate gear wheel – camshaft	0.05 - 0.25 mm
Intermediate gear wheel – injection pump	0.05 - 0.25 mm
Max. permissible lateral runout of the wheels	0.05 mm
Intermediate gear wheel (with friction bearing):	
– Inner diameter, intermediate gear wheel bearing bush (fitted)	55.000 - 55.030 mm
– Diameter, bearing journal for intermediate gear wheel	54.951 - 54.970 mm
Inner diameter, camshaft gear wheel	32.000 - 32.025 mm
Diameter, front end of the camshaft	32.043 - 32.059 mm

Timing marks:

The alignment of the timing marks on the gear wheels correspond to the top dead centre of the piston in the 1st cylinder, between the compression stroke and firing stroke.

On the crankshaft gear wheel 2 dots on the teeth

On the intermediate gear wheel:

- opposite the crankshaft gear wheel "0" mark on the tooth
- opposite the camshaft gear wheel 1 dot on the tooth
- opposite the injection pump gear wheel 1 dot at the tooth gap

On the camshaft gear wheel 1 dot at the tooth gap

On the injection pump gear wheel 1 dot on the tooth

Con-rods

Inner diameter, piston-pin bush

(bearing bush pressed into the con-rod)	40.025 - 40.040 mm
Outer diameter of the piston-pin bush	44.082 - 44.120 mm
Overlap of the bearing seat (press fit) in the con-rod	0.057 - 0.120 mm
Bore, seat for piston-pin bush	44.000 - 44.025 mm
Bore, con-rod bearing end	71.730 - 71.749 mm

Thickness of the con-rod bearing shells:

- Standard
- 1st. repair level 0.25 mm
- 2nd. repair level 0.50 mm
- 3rd. repair level 1.00 mm
- 4th. repair level 1.50 mm

Con-rod bearing play

Con-rod bearing axial play

Alignment of the con-rod bearing bore to the piston-pin bearing bore

Parallelism of the con-rod bearing bore to the piston-pin bearing bore

The weight markings are punched in the bottom end of the con-rods

(on the camshaft side)

Max. permissible weight difference between con-rods in the same engine

Pistons, piston rings and piston pins

Smallest gap between the piston and cylinder head (measured through the bore for the nozzle holder seat using lead wire)	0.900 - 1.150 mm
Piston diameter (measured 17 mm above the lower edge of the piston)	107.873 - 107.887 mm
Diameter, piston pin bore hole in the piston	40.003 - 40.009 mm
Diameter, piston pin	39.991 - 40.000 mm

Width of the piston ring grooves:

– 1st. groove (rectangular compression ring)	2.560 - 2.580 mm
– 2nd. groove	2.520 - 2.540 mm
– 3rd. groove	4.040 - 4.060 mm

Vertical play of the piston rings in their grooves:

– 1st. groove (rectangular compression ring)	0.07 - 0.102 mm
– 2nd. groove	0.03 - 0.062 mm
– 3rd. groove	0.05 - 0.082 mm
– Wear limit	0.15 mm

Piston ring height (in direction of cylinder):

– 1st. groove (rectangular compression ring)	2.478 - 2.490 mm
– 2nd. groove	2.478 - 2.490 mm
– 3rd. groove	3.975 - 3.990 mm

End play of piston rings (with piston fitted):

– 1st. groove (wedge-type compression ring)	0.40 - 0.55 mm
– 1st. groove (rectangular compression ring)	0.30 - 0.45 mm
– 2nd. groove	0.60 - 0.80 mm
– 3rd. groove	0.30 - 0.60 mm
– Wear limit, rings 1 and 3	1.0 mm
– Wear limit, ring 2	1.5 mm

Max. permissible weight difference between pistons in the same engine 25 g

NOTE: When fitting the pistons, make sure the piston recess is on the same side as the nozzle holders.

Lubrication system

Oil pressure at normal operating temperature:

– idling	at least 1.0 bar
– at operational speed	2.5 - 5 bar
Lubrication oil filter overflow valve opens at a differential pressure of	$2 \pm 0,5$ bar
Oil pressure switch opens at	$p > 0.5$ bar

Engine types 620.95 and 620.96:

Spring in oil pressure valve: length, relaxed	49.5 mm
Spring length and force (with oil pressure valve fitted)	28.5 mm/76 N

Engine types 620.97, 620.98 and 620.99:

Spring in oil pressure valve: length, relaxed	49.8 mm
Spring length and force (with oil pressure valve fitted)	28.5 mm/127 N

Oil pressure alarm at

Fault code EEM99 Indicated on ADIC

Optical and acoustic warning, automatic

engine shutoff after 30 seconds

Overflow valves for the piston cooling nozzles: Opening pressure $3 \pm 0,25$ bar

Lubrication oil pump

Tooth flank play when the crankshaft lies firmly against the under side of the bearing	
– between the crankshaft gear wheel and oil pump gear wheel	0.05 - 0.025 mm
– between the oil pump gear wheels	0.16 - 0.26 mm
Diameter of the drive shaft in the housing and cover	17.966 - 17.984 mm
Diameter of the drive shaft bearing bores	18.000 - 18.018 mm
Diameter of the fixed shaft near the pump gear wheel	17.966 - 17.984 mm
Diameter of the bearing bore in the pump gear wheel	18.000 - 18.018 mm
Diameter of the fixed shaft in the pump housing	20.035 - 20.048 mm
Depth of the drive shaft end below the housing surface	0.5 - 1.0 mm
Thickness of the housing seal	0.06 - 0.08 mm
Outer diameter of the gear wheels	55.824 - 55.870 mm
Housing diameter	56.000 - 56.120 mm
Width of the gear wheels	32.000 - 32.027 mm
Axial play of the gear wheels	0.03 - 0.11 mm
Housing depth	32.000 - 32.043 mm
Number of teeth on the drive gear wheel	46

Thermostat

Type, version	∅ 54 mm/single circuit
Starts opening at	79 °C ^{±2}
Fully open at	94 °C
Max. stroke	7.5 mm
Type, version	∅67/dual-circuit
Starts opening at	83 °C ^{±2}
Fully open at	95 °C
Max. stroke	8 mm

Coolant temperature indication and monitoring (signal from sensor B22)

Display on ADIC	analog
Warning at ADIC when temperature	> 106 ^{±3} °C
Fault code EEM112 (test values for sensor: see Service Tool)	
Acoustic alarm (additionally) when temperature	> 113 ^{±3} °C
Fault code EEM113 (test values for sensor: see Service Tool)	

Coolant pump

Bearing outer diameter	52 mm
Bearing housing diameter	51.979 - 52.009 mm
Shaft diameter at bearing	19.980 - 19.993 mm
Shaft diameter at impeller	15.907 - 15.920 mm
Diameter of impeller bore hole	15.876 - 15.894 mm
Clearance between impeller and rear side of housing	0.8 - 1.2 mm
(must be observed when pressed on)	
Permissible imbalance of the fan	max. 0.3 Ncm max (30 pcm)
V-belt tension, when pressed in between the two pulleys, amount of give	10 - 15 mm

Schwitzer turbocharger S200

Axial play of the shaft	max. 0.10 mm
Radial play of the shaft (compressor end)	max. 0.88 mm
Tightening torque for the compressor housing bolts	13.60 Nm
Tightening torque for the turbine housing bolts	21.00 Nm
Tightening torque for the shaft nut (compressor end)	13.60 Nm

Tightening torques

Cylinder head nuts and bolts (up to engine number N 8956)	80 Nm+90°+90° (+60° at coolant temperature of 75 °C)
Cylinder head nuts and bolts (from engine number N 8957)	80 Nm+90°+90°
Cylinder head bolts in the cylinder block	30 Nm
Crankshaft bearing bolts	200 Nm
Con-rod bolts (Torx E18)	40 Nm + 90°
Nut on crankshaft (face)	1000 Nm
Belt pulley bolts	30 Nm
Securing bolts for flywheel	150 Nm
Securing bolts for flywheel casing:	
– internal M10 bolts	80 Nm
– external M12 bolts	150 Nm
Retaining screws for intermediate gear wheel (with friction bearing):	
– M10	60 Nm
– M14	200 Nm
Overflow valve, piston cooling nozzle (620.97, 620.98, 620.99)	30 Nm
Nut for lubrication oil pump gear wheel	60 Nm
Retaining screws for lubrication oil pump	60 Nm
Connecting part for (engine) oil cooler	60 Nm
Nut for belt pulley on coolant pump	120 Nm
Fastening, Visco fan on Visco hub	30 Nm
Nuts/bolts for exhaust manifold	50 Nm
Bolts for air intake channel	30 Nm
Nut for injection pump gear wheel	90 Nm
Retaining nuts, nozzle holder (for bolts)	15 Nm
Injection nozzle union nut	60 Nm
Injection line union nut	25 Nm

NOTE: Use washers for aluminium parts.

If no particular tightening torques are specified,
always use the values specified in the table below.

	M8	M10
Cast iron	35 \pm 5 Nm	70 \pm 5 Nm
Aluminium	25 \pm 5 Nm	50 \pm 5 Nm

Bolts for the self-supporting oil sump

1	M8	25 Nm
2	M10	90 Nm
3	M14	160 Nm
4	M20	600 Nm

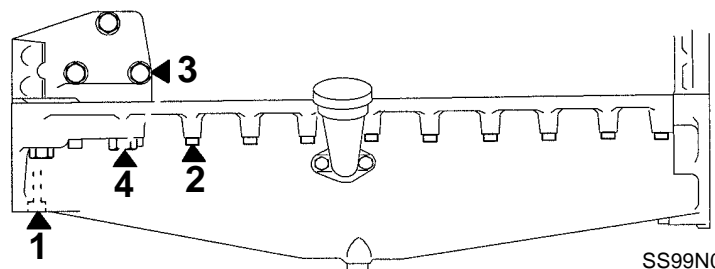

CONSTRUCTION

General

The 620 series CNH diesel engines are water-cooled, four stroke, in-line engines with direct injection. All models are equipped with wet, replaceable cylinder liners, an exhaust turbocharger and charge-air cooling (air/air). As the engines are equipped with an electronic diesel control system in conjunction with an electronic engine control system (CAN network including solenoid valve-controlled distributor injection pump VP30), all models comply with the exhaust-gas regulations in accordance with Tier 2.

Cylinder block

The rib-reinforced cylinder block forms the main engine unit, onto which other engine components are mounted.

The wet, replaceable cylinder liners are supported in the middle, thus reducing vibration and the coolant flow is mainly directed to the upper section of the cylinder liners.

The bottom part of the cylinder liner and the cylinder block are sealed by three O-rings, which are inserted in the grooves in the cylinder liner. The upper part is sealed by the cylinder head gasket.

The camshaft is located in the cylinder block. All camshaft bearings are equipped with replaceable cylinder liners.

Guide bearings are fitted on both sides of the rear crankshaft bearings (crankshaft – axial bearings).

Flywheel casing

The flywheel casing is fitted at the rear end of the cylinder block. The seal for the rear end of the crankshaft is fitted in a bore hole in the casing. The flange for the starter is located in the flywheel casing.

The underside of the flywheel casing is used as a sealing surface for the oil sump seal. This means that the underside of the cylinder block must be flush with the flywheel casing. When the flywheel casing is fitted, its position is determined by sprung dowel pins.

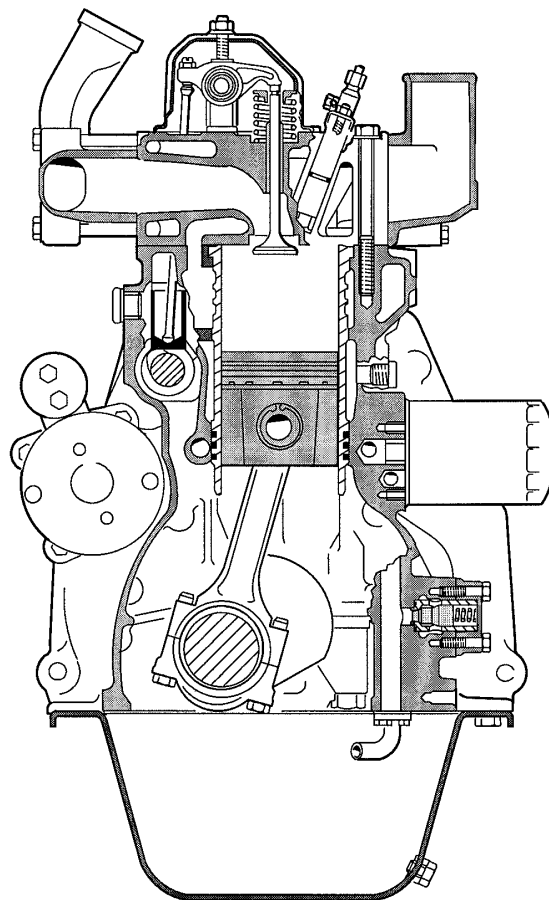

SS00F035

Valve mechanism

The valve mechanism is operated by the camshaft in the cylinder block. The drive power is transferred via valve tappets and push rods. The camshaft gear wheel is force fitted on the camshaft and fixed (radially) by a feather key. The bearings are lubricated with pressure oil through bore holes in the engine block.

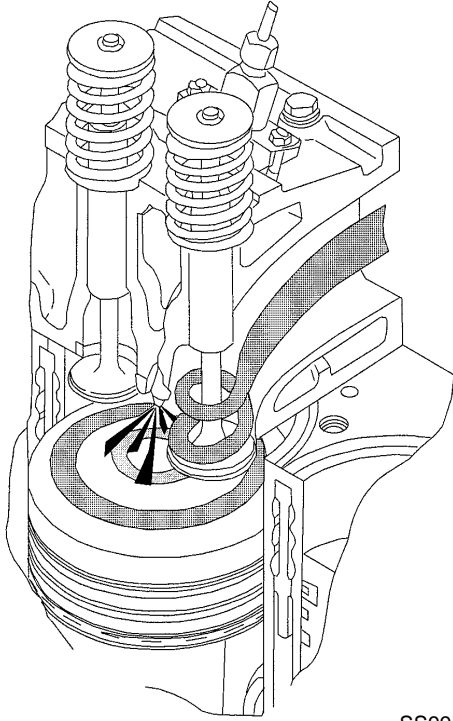

SS99N017

Cylinder head

The engines are equipped with two interchangeable cylinder heads. Each cylinder has its own intake and outlet channels in the cylinder head. To compensate for thermal stress, an inlet valve is fitted between the outlet valves

The cylinder head bolts are high-tensile pre-tensioned bolts, which are tightened to their elongation limit in accordance with the angular tightening principle. Due to the high degree of elongation, the retaining power is kept constant throughout the entire service life, and the bolts do not therefore have to be checked and tightened.

The injection nozzle seats are integrated into the cylinder head. The inlet and outlet valve guides are identical and can be interchanged. Furthermore, the in/outlet valves are fitted with replaceable valve seat inserts.



Suggest:

If the above button click is invalid.

Please download this document

first, and then click the above link

to download the complete manual.

Thank you so much for reading

Crankshaft drive

The crankshaft is made from forged chrome alloy special steel and the bearing and sealing surfaces are inductively tempered. The bearing points can be re-ground four times without having to be re-tempered. The gear wheels are force fitted at the front end of the crankshaft. They are used to drive the camshaft, injection pump and oil pump. In addition, the front end of the crankshaft has key-ways for seating the drive hub. The V-belt pulley and the torsional vibration damper (with rubber element) are fitted on the hub. The front PTO shaft (if fitted) is also driven via this hub. An oil deflector ring is fitted between the hub and gear wheel and a dust seal is fitted on the hub to protect the crankshaft sealing ring. The transmitter wheel for the engine speed sensor is fitted on a crankshaft web.

A crankshaft bearing is located on both sides of each cylinder. There are thus seven crankshaft bearings. The crankshaft axial bearings are located on both sides of the rearmost crankshaft bearing. The flywheel is mounted at the rear end of the crankshaft and carries a force fitted crown gear.

The forged con-rods have an I-shaped cross-section. The con-rod bearing is split horizontally. The bearing cover is secured by means of two special bolts. The upper part has a wedge-shaped bearing seat in which the small end bearing bush is force fitted.

The piston is made of an eutectic aluminium alloy. There is a combustion space in the piston head. The shape of the optimised combustion space ensures an optimal carburetion of air and fuel. The pistons have different types of piston rings depending on the engine type (see next paragraph).

The pistons are equipped with two compression rings and an oil scraper ring. In the case of engine types 620.95 and 620.96, the top molybdenum-coated piston ring has a rectangular cross-section. Engine types 620.97, 620.98 and 620.99 have a top piston ring with a trapezoidal cross-section.

The middle piston ring is a taper face ring (the outer diameter has a conical surface).

The oil scraper ring is sprung and has two chrome-plated scraping edges.

The pistons are ring carrier pistons (the piston has a special cast iron ring carrier cast into it to seat the top piston ring). The friction surface of the piston skirt also has a graphite coating to ensure optimal running-in.

In the case of engine types 620.97, 620.98 and 620.99, the piston head is cooled from below by additional oil spray as soon as the oil pressure exceeds 3 bar.

<https://www.ebooklibonline.com>

Hello dear friend!

Thank you very much for reading.

Enter the link into your browser.

The full manual is available for immediate download.

<https://www.ebooklibonline.com>